

# EPSON

Laser Printer

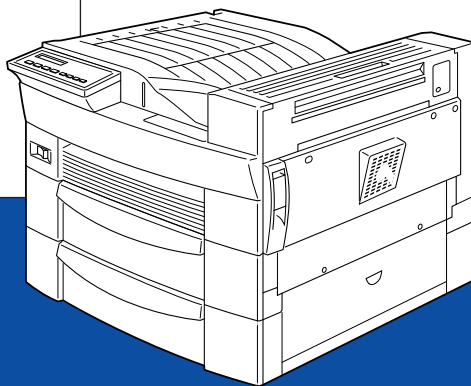

**EPSON EPL-N2750**

## *Setup Guide*

4012106-01  
XXX

# Where to Find Information

## ***Setup Guide (this manual)***

Provides you with information on assembling the printer's parts, installing options, and connecting the printer to the computer.

## ***Administrator's Guide (online guide)***

Provides network administrators with information on both the printer driver and network settings.

## ***Reference Guide***

Provides you with detailed information on the printer's functions, optional products, maintenance, troubleshooting, and technical specifications.

## ***Quick Reference***

Provides you with a list of LCD panel messages and information on replacing the imaging cartridge and clearing jammed paper. Place it in the small box provided with the printer for safekeeping and easy access.

## ***Online Help***

Provides you with detailed information and instructions on the printer software that controls your printer. Online help is automatically installed when you install the printer's software.

# EPSON®

Laser Printer

## EPL-N2750

All rights reserved. No part of this publication may be reproduced, stored in a retrieval system, or transmitted in any form or by any means, mechanical, photocopying, recording, or otherwise, without the prior written permission of SEIKO EPSON CORPORATION. No patent liability is assumed with respect to the use of the information contained herein. Neither is any liability assumed for damages resulting from the use of the information contained herein.

Neither SEIKO EPSON CORPORATION nor its affiliates shall be liable to the purchaser of this product or third parties for damages, losses, costs, or expenses incurred by purchaser or third parties as a result of: accident, misuse, or abuse of this product or unauthorized modifications, repairs, or alterations to this product, or (excluding the U.S.) failure to strictly comply with SEIKO EPSON CORPORATION's operating and maintenance instructions.

SEIKO EPSON CORPORATION shall not be liable against any damages or problems arising from the use of any options or any consumable products other than those designated as Original EPSON Products or EPSON Approved Products by SEIKO EPSON CORPORATION.

EPSON and EPSON ESC/P are registered trademarks and EPSON ESC/P2 is a trademark of SEIKO EPSON CORPORATION.

Speedo, Fontware, FaceLift, Swiss, and Dutch are trademarks of Bitstream Inc.

CG Times and CG Omega are registered trademarks of Miles, Inc.

Univers is a registered trademark of Linotype AG and/or its subsidiaries.

Antique Olive is a trademark of Fonderie Olive.

Albertus is a trademark of Monotype Corporation plc.

Coronet is a trademark of Ludlow Industries (UK) Ltd.

Arial and Times New Roman are registered trademarks of Monotype Corporation plc.

Dutch and Swiss are trademarks of Bitstream Inc.

Times, Helvetica and Palatino are registered trademarks of the Linotype AG and/or its subsidiaries.

ITC AvanGarde Gothic, ITC Bookman, ITC Zapf Chancery and ITC Zapf Dingbats are registered trademarks of the International Typeface Corporation.

Century SchoolBook is registered trademark of the Kingsley-ATF Type Corporation.

New Century Schoolbook is a trademark of the Linotype AG and/or its subsidiaries.

HP and HP LaserJet are registered trademarks of Hewlett-Packard Company.

Adobe and PostScript are trademarks of Adobe Systems Incorporated, which may be registered in certain jurisdictions.

The PCL6-compatible interpreter is a customized version of IPS-PRINT SIX © developed by Xionics Document Technologies, Inc., a subsidiary of Oak Technology, Inc.

**General Notice:** Other product names used herein are for identification purposes only and may be trademarks of their respective owners. EPSON disclaims any and all rights in those marks.

Copyright © 2000 by SEIKO EPSON CORPORATION, Nagano, Japan.



Printed on Recycled Paper.

## Setup Guide

---

---

# Printer Parts

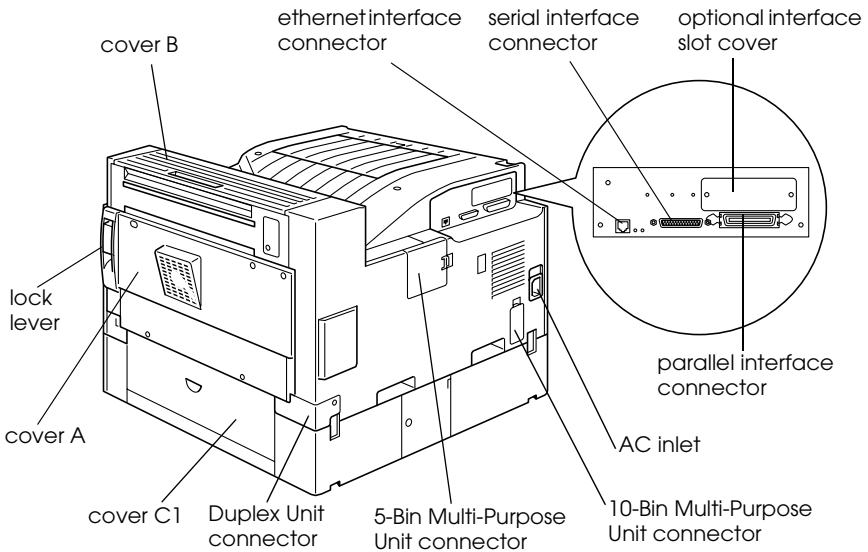
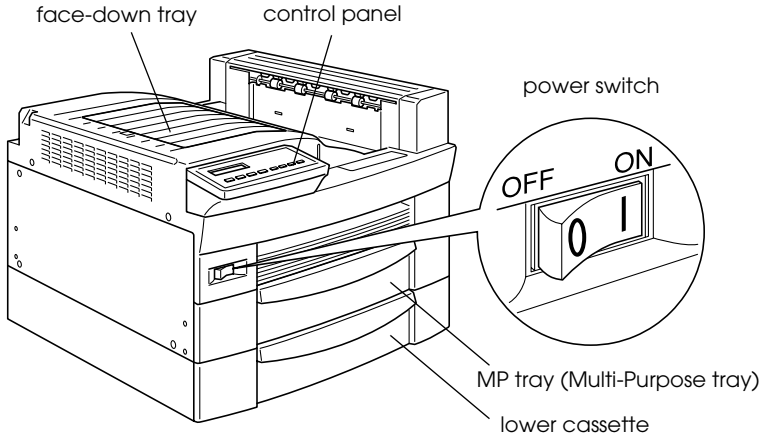

---

# Contents

Printer Parts .....	ii
---------------------	----

## **1 Safety Instructions**

---

Laser Printer Precautions .....	1
Important Safety Instructions .....	3
Warnings, Cautions, and Notes.....	5

## **2 Assembling the Printer**

---

Attaching the Quick Reference Box .....	6
Attaching the Side Cover .....	7
Installing the Imaging Cartridge.....	8

## **3 Installing Options**

---

500-Sheet Lower Cassette Unit .....	13
Large Capacity Paper Unit.....	18
Duplex Unit .....	25
Hard Disk Drive.....	31
Memory Module .....	36
Adobe PostScript 3 ROM Module.....	42
Interface Card.....	47
5-Bin Multi-Purpose Unit.....	48
10-Bin Multi-Purpose Unit.....	54

## **4 Plugging in the Printer**

---

Attaching the Power Cord .....	62
Loading Paper .....	63

Loading paper into the MP tray ..... 63  
Loading paper into the lower cassette ..... 67  
Selecting the paper size ..... 72  
Testing the Printer ..... 72  
    Printing a status sheet..... 72  
Connecting the Printer to a Computer ..... 74

**5 System Requirements**

---

**6 For DOS Programs**

---

**7 After This...**

---

What to do Next ..... 78  
Using the Online Guide..... 78

**8 Safety Information**

---

ENERGY STAR Compliance..... 79  
Ozone Safety ..... 79  
Laser Safety ..... 80  
For United Kingdom Users..... 82

**Index**

---

---

# 1 Safety Instructions

---

---

## Laser Printer Precautions

---

This printer uses laser technology. The following list of precautions applies whenever you open the printer cover. Even if you are familiar with other types of printers, be sure to follow these precautions carefully to ensure safe, efficient operation:

- ❑ Do not touch the areas specified on the caution labels inside cover A and cover B. If the printer has been in use, the fuser can be very hot.

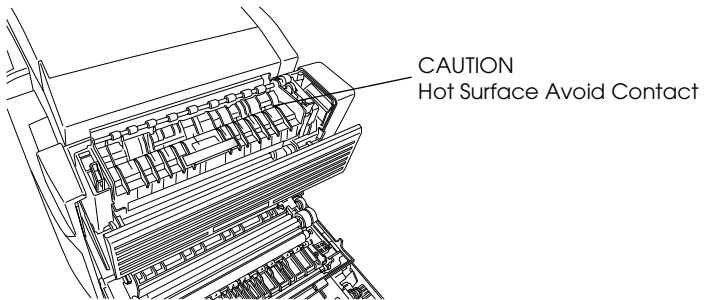
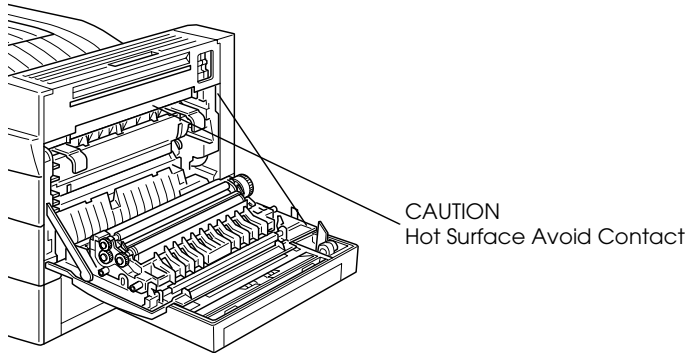

- ❑ Avoid touching the components inside the printer unless instructed to do so in this guide.
- ❑ Never force the printer's components into place. Although the printer is designed to be sturdy, rough handling can damage it.
- ❑ Be sure not to scratch the surface of the drum. When you remove the imaging cartridge from the printer, always set the unit on a clean, smooth surface. Also, avoid touching the drum, since oil from your skin can permanently damage its surface and may affect print quality.
- ❑ Do not turn the cartridge upside down or stand it on its ends.
- ❑ Protect the light-sensitive drum from exposure to light. Avoid exposing the imaging cartridge to room light any longer than necessary. Do not open the drum's protective cover. Overexposing the drum may cause abnormally dark or light areas to appear on the printed page and reduce the service life of the drum.

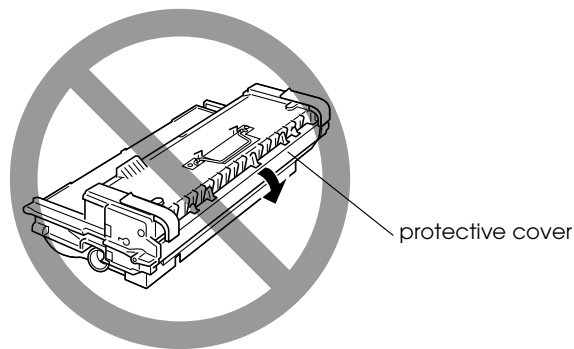

- ❑ When handling the cartridge, always set it on a clean, smooth surface.
- ❑ Do not attempt to modify or take the cartridge apart. It cannot be refilled.



- ❑ Do not touch the toner and avoid all contact with your eyes.
- ❑ Wait for at least one hour before using an imaging cartridge after moving it from a cool to a warm environment to prevent damage from condensation.



**Warning:**

*Do not dispose of used imaging cartridges in fire, as they can explode and cause injury. Dispose of them according to local regulations.*

- ❑ To get the best print quality, do not store the imaging cartridge in an area subject to direct sunlight, dust, salty air, or corrosive gases (such as ammonia). Avoid locations subject to extreme or rapid changes in temperature or humidity.
- ❑ Be sure to keep consumable components out of the reach of children.

**Hinweis:**

- ❑ *Die Geräteanschlußleitung muß den einschlägigen Normen genügen. Es muß eine dreiadrige Leitung verwendet werden. Die Anschlußleitung darf nicht leichter als H05VV-F oder H05VVH2-F sein.*
- ❑ *Maschinenlärminformations-Verordnung-3. GSGV, 18. 01. 1991: Der arbeitsplatzbezogene schalldruckpegel beträgt 70 dB (A) oder weniger gemäß ISO 7779.*

---

## **Important Safety Instructions**

Read all of these instructions before operating your printer:

- ❑ Follow all warnings and instructions marked on the printer.
- ❑ Unplug the printer from the wall outlet before cleaning.

- ❑ Use a damp cloth for cleaning and do not use liquid or aerosol cleaners.
- ❑ Do not use this printer near water.
- ❑ Do not place the printer on an unstable cart, stand, or table.
- ❑ Slots and openings in the cabinet and at the back and bottom of the printer are provided for ventilation. Do not block or cover them and do not put the printer on beds, sofas, rugs, or other soft surfaces that may block ventilation. Do not place the printer in an enclosure unless proper ventilation is provided.
- ❑ Use the type of power source indicated on the label. If you are not sure of the type of power available, consult your dealer or local power company.
- ❑ If you are unable to insert the plug into the outlet, contact your electrician to have your outlet repaired or replaced.
- ❑ Do not put your printer where the cord might be stepped on.
- ❑ Avoid using outlets that other appliances are plugged into.
- ❑ Only use an outlet that meets the power requirements for this printer.
- ❑ Never push objects of any kind through cabinet slots as they may touch dangerous voltage points or short out parts which could result in fire or electric shock. Never spill liquid of any kind on the printer.
- ❑ Except as specifically explained in this guide, do not attempt to service this product yourself. Opening or removing covers that are marked **Do Not Remove** exposes you to dangerous voltage. Refer all servicing in those compartments to a qualified service representative.

- ❑ Unplug the printer from the wall outlet and refer servicing to a qualified service representative under the following conditions:
  - A. If liquid has been spilled into the printer.
  - B. If the printer has been exposed to rain or water.
  - C. If the printer does not operate normally when the operating instructions are followed. Adjust only those controls that are covered by the operating instructions since improper adjustment of other controls may result in damage and will often require extensive work by a qualified technician to restore the product to normal operation.
  - D. If the printer has been dropped or the cabinet has been damaged.
  - E. If the printer exhibits a distinct change in performance and a message indicating a need for service appears on the LCD panel.
  - F. When the power cord or plug is damaged or frayed.

---

## **Warnings, Cautions, and Notes**



### **Warnings**

*must be followed carefully to avoid bodily injury.*



### **Cautions**

*must be observed to avoid damage to your equipment.*

### **Notes**

*contain important information and useful tips on the operation of your printer.*

---

## 2 Assembling the Printer

---

---

### Attaching the Quick Reference Box

Use the quick reference box for storing the *Quick Reference* if this guide is included with your printer. Insert the knob on the bottom of the quick reference box into the slot on the left side of the printer. Then attach the quick reference box by inserting the knobs into the slots on each side.

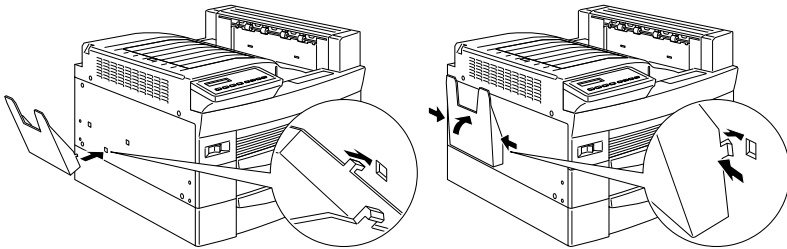

If you installed the optional 10-Bin Multi-Purpose Unit, attach the quick reference box to the back of the printer as shown below.

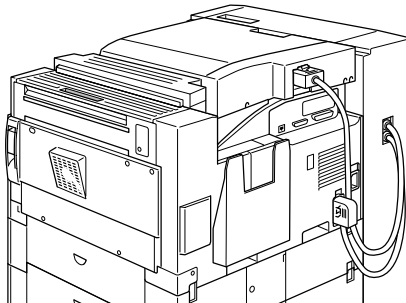

---

## Attaching the Side Cover

Attach the printer's side cover unless the optional Large Capacity Paper Unit is installed.

Follow these steps to attach the printer's side cover:

**Note:**

*If the optional 500-sheet Lower Cassette Unit is installed, attach the side cover to the lowermost 500-sheet Lower Cassette Unit.*

1. Remove the side cover from the box and confirm the direction in which it is to be attached.

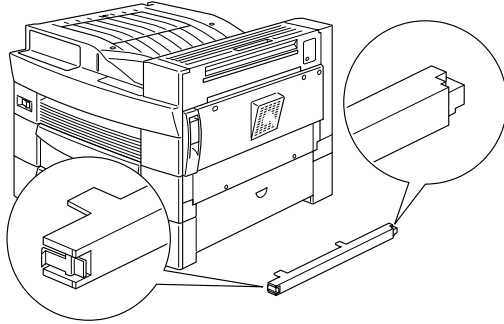

2. Attach the side cover to the bottom of the printer by first fitting the side cover into the slot to the rear of the printer, then fitting the other end into the slot to the front.

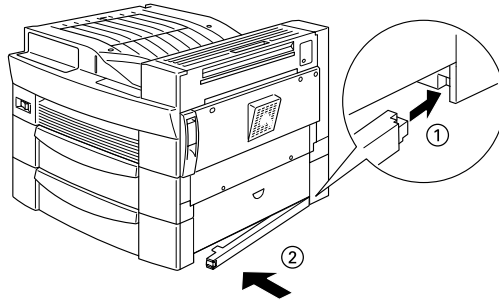

---

## ***Installing the Imaging Cartridge***

Follow these steps to install the imaging cartridge:

1. While holding the imaging cartridge horizontally, gently rock it back and forth a few times to distribute the toner evenly.

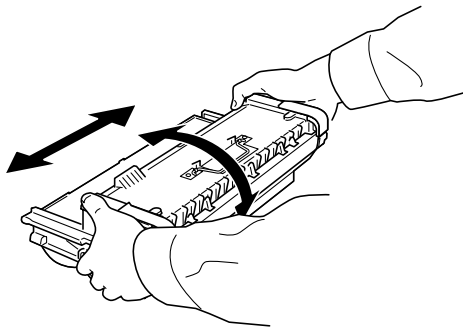



**Caution:**

- ❑ Do not turn the imaging cartridge upside down.
- ❑ Do not open the drum's protective cover and avoid exposing the imaging cartridge to room light any longer than necessary. Overexposing the cartridge may cause abnormally dark or light areas to appear on the printed page and reduce the service life of the cartridge.

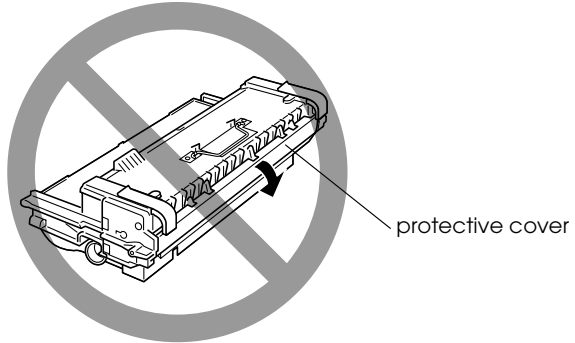

2. To release the spring-loaded carrying handles on the sides of the new cartridge, hold down each handle with your hand and remove the tape that is affixed to the handle. Release the handle by removing your hand from it gently and the handle will automatically spring out.



**Warning:**

*When you remove the tape, the handle may spring out quickly enough to hurt your fingers. To avoid this, hold the handle firmly in position while peeling off the tape.*

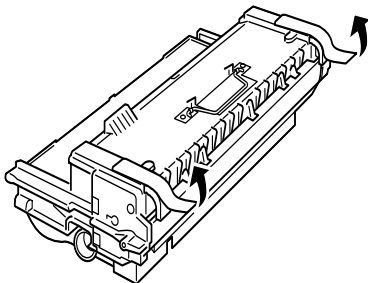

3. Open cover A gently by pulling the latch.

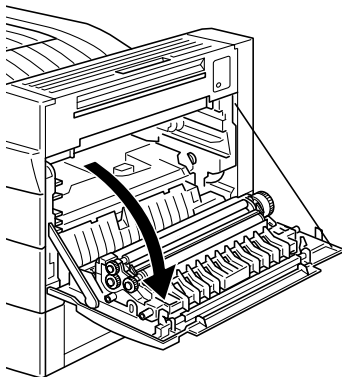





**Warning:**

*Do not touch the hot areas indicated by caution labels inside cover A.*

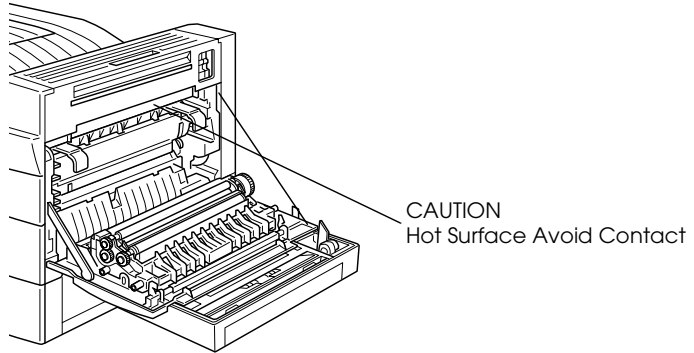

4. Holding the left and right handles of the imaging cartridge, insert it into the printer until it is firmly seated.

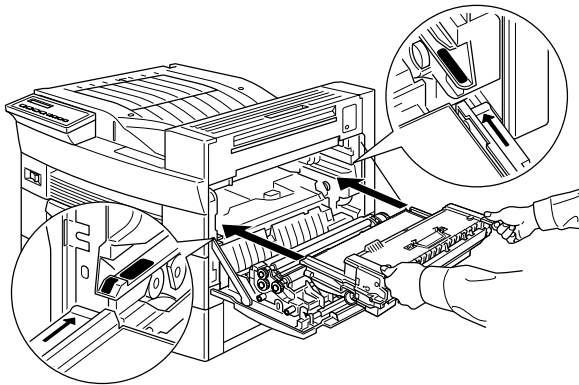

5. Close cover A by pushing it up and into the printer.

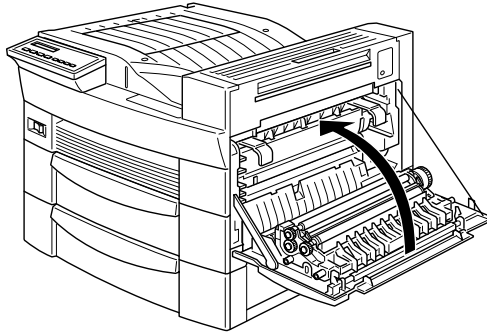

**Caution:** *Never transport the printer with the imaging cartridge installed.*

---

## **3** *Installing Options*

---

This chapter provides you with the installation procedures of options that are available for this printer.

---

### ***500-Sheet Lower Cassette Unit***

It is best to install the optional 500-Sheet Lower Cassette Unit (C81319\*) when first setting up the printer. You can install up to two optional 500-Sheet Lower Cassette Units, or one optional 500-Sheet Lower Cassette Unit plus the optional Large Capacity Paper Unit.

Please note that you will need the assistance of at least two other people to lift up the printer when installing this option.

Follow these steps to install the optional 500-Sheet Lower Cassette Unit:

1. Open the shipping carton.
2. Remove the inserts and all other protective materials inside the box. Make sure the contents of the package match the items on the included documentation. Remove the packaging materials and any other items from the 500-Sheet Lower Cassette Unit and store them for future use.
3. Lift the unit out of the box and place it near the printer.

If you plan to install more than one 500-Sheet Lower Cassette Unit, stack the cassettes with the front of each cassette facing the same direction.

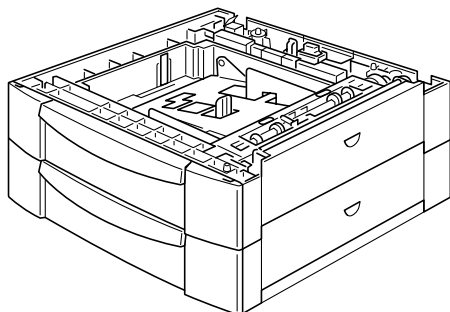

If you plan to install the optional Large Capacity Paper Unit at the same time, refer to the instructions under “Large Capacity Paper Unit” on page 18 to complete the installation of both units.

4. Remove the side cover from the bottom of the printer.

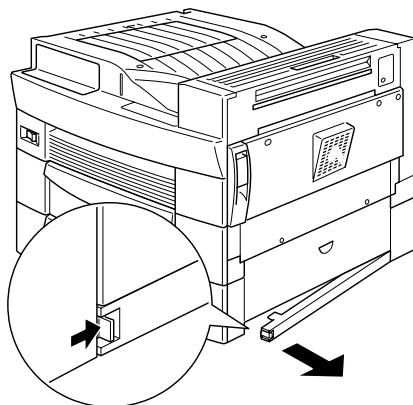

5. With the assistance of two or more people, grasp the printer at the positions indicated below and lift it carefully.

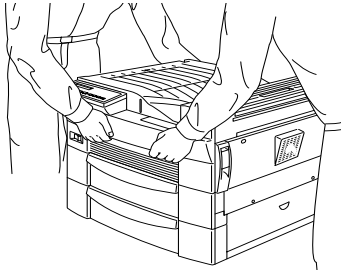

front

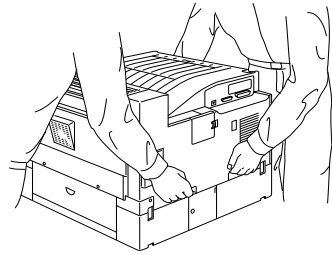

rear



**Caution:**

*The printer weighs about 30 kg (66.1 lb); always lift it with two or more people.*

6. Align each of the printer's corners with those of the unit, then lower the printer until it rests securely on the unit.

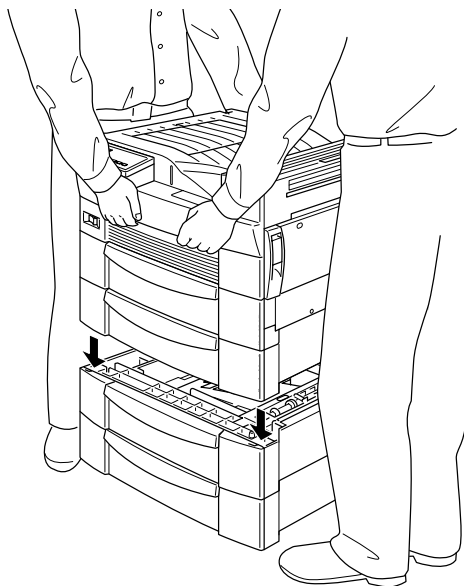

7. Make sure all corners of the printer fit firmly onto the unit.
8. Pull out the paper cassette and fasten the unit using the fittings and screws provided.

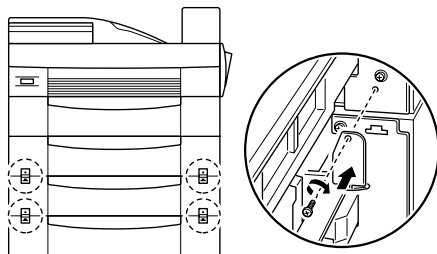

9. On the back of the printer, fasten the unit using the fittings and screws provided.

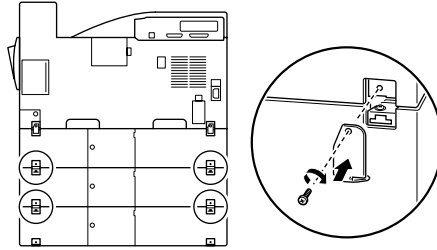

10. Pull the paper cassette out and remove the protective materials.

11. Attach the side cover to the bottom of the cassette unit as shown below.

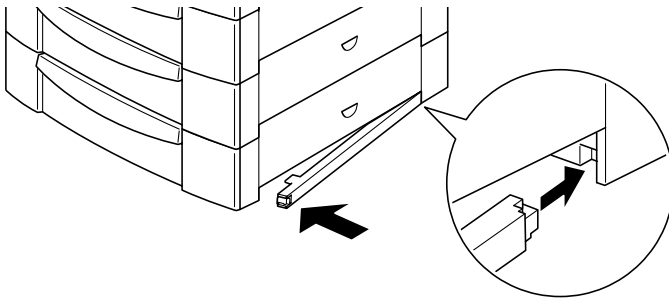

12. Peel the appropriate cover and cassette numbering labels from the label sheet included with the 500-Sheet Lower Cassette Unit and attach them to the unit.

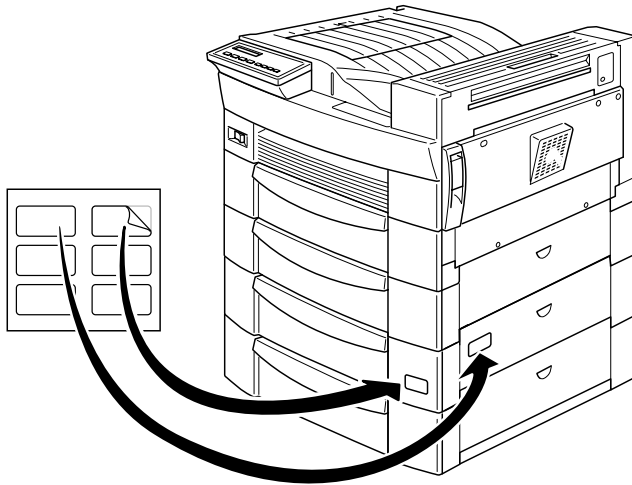

---

## ***Large Capacity Paper Unit***

It is best to install the optional Large Capacity Paper Unit (C81322\*) when first setting up the printer. Please note that you will need the assistance of at least two other people to lift up the printer when installing this option.

Follow these steps to install the optional Large Capacity Paper Unit:

1. Open the shipping carton.
2. Remove the inserts and all other protective materials inside the box. Make sure the contents of the package match the items on the included documentation. Remove the packaging materials and any other items from the unit and store them for future use.



3. With the assistance of two or more people, lift the Large Capacity Paper Unit out of the box and place it near the printer.

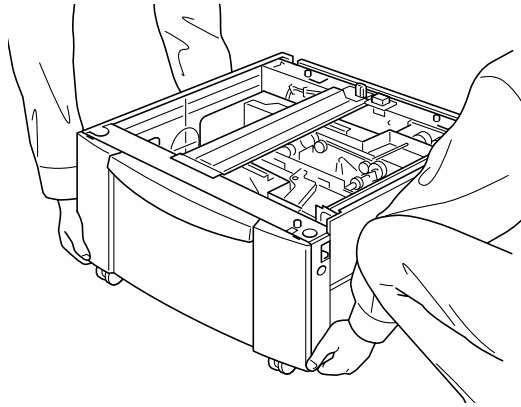

**Note:**

*The unit has four handles that you can use to lift it with. Pull the handles out from the locations shown below when you need to use them.*

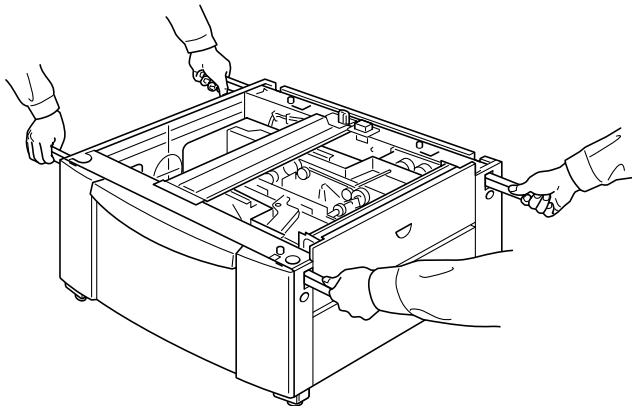

4. You will find three casters at the bottom of the Large Capacity Paper Unit. Lock the casters by pushing their levers down.

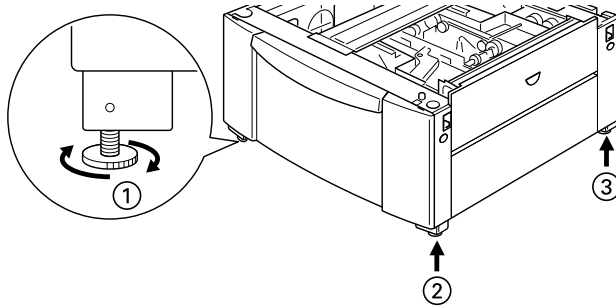

5. If you are also installing an optional 500-Sheet Lower Cassette Unit, stack it on top of the Large Capacity Paper Unit. For instructions on how to prepare the 500-Sheet Lower Cassette Unit for installation, see “500-Sheet Lower Cassette Unit” on page 13.

**Note:**

*All subsequent illustrations show both an optional 500-Sheet Lower Cassette Unit and an optional Large Capacity Paper Unit.*

6. Remove the side cover from the bottom of the printer.

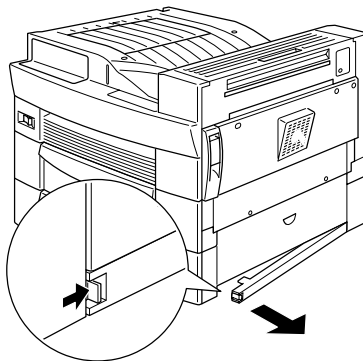

7. With the assistance of two or more people, grasp the printer at the positions indicated below and lift it carefully.

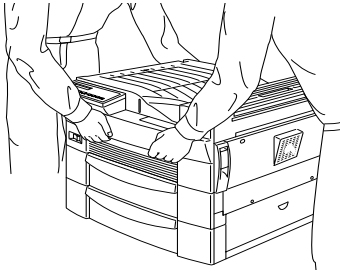

front

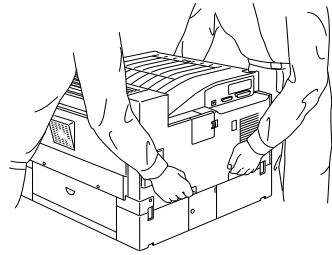

rear



**Caution:**

*The printer weighs about 30 kg (66.1 lb); always lift it with two or more people.*

- Align each of the printer's corners with those of the unit, then lower the printer until it rests securely on the unit.

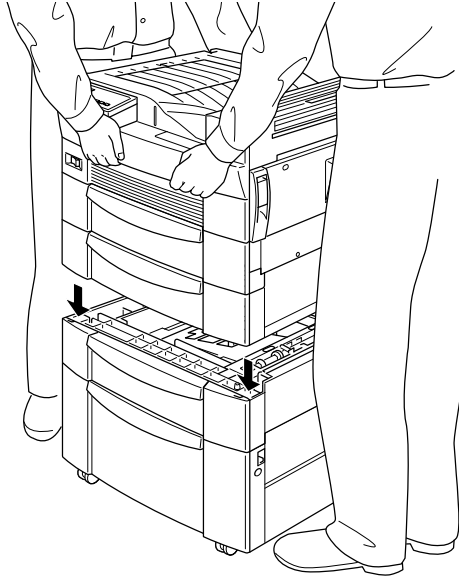

- Make sure all corners of the printer fit firmly onto the unit. Then pull out the paper cassette and fasten the unit using the fittings and screws provided.

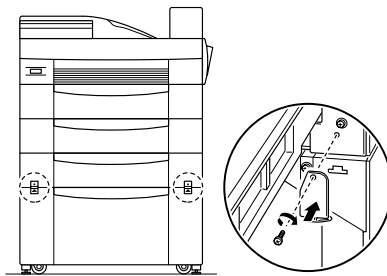

**Note:**

*Also fasten the 500-Sheet Lower Cassette Unit with the fittings and screws provided if you are installing both options at the same time.*

10. On the back of the printer, fasten the unit using the fittings and screws provided.

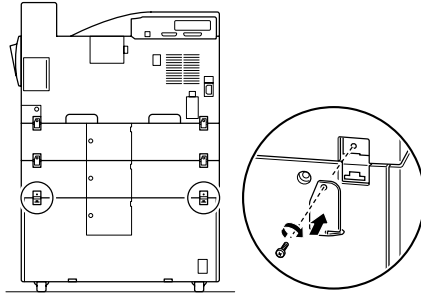

**Note:**

*Also fasten the 500-Sheet Lower Cassette Unit with the fittings and screws provided if you are installing both options at the same time.*

11. Pull the paper cassette out of the unit and remove the protective materials.
12. Peel the appropriate cover and cassette numbering labels from the label sheet included with the Large Capacity Paper Unit and attach them to the unit.

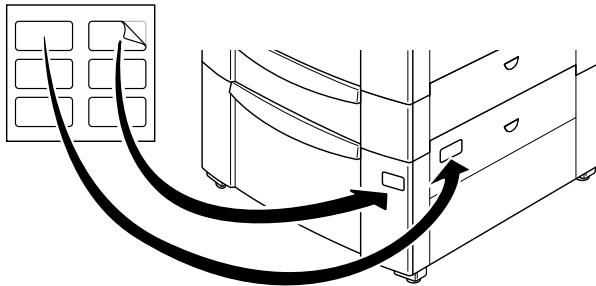

13. Pull out the paper cassette and attach the printer supports and printer support covers to the front of the printer, then attach the printer supports to the back of the printer.

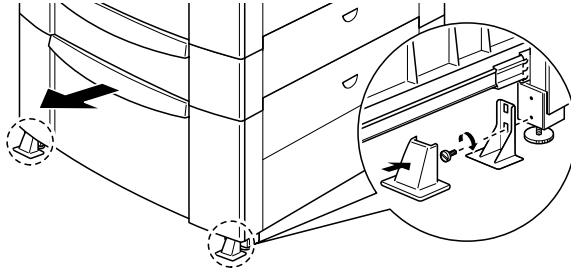

14. Attach the included L-shaped printer support to the side of the unit as shown below.

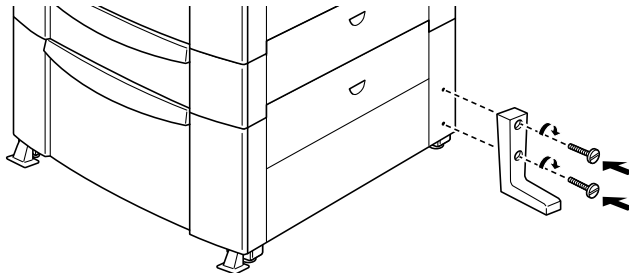

---

## Duplex Unit

Installing the optional Duplex Unit (C81318\*) allows you to automatically print on both sides of the paper.

Follow these steps to install the optional Duplex Unit:

1. Open the shipping carton.
2. Remove the inserts and all other protective materials inside the box. Make sure the contents of the package match the items on the included documentation. Remove the packaging materials and any other items from the unit and store them for future use.



**Caution:**

*When removing the Duplex Unit from the box, do not grasp the area indicated by the warning label shown below. Otherwise, you may damage the unit.*

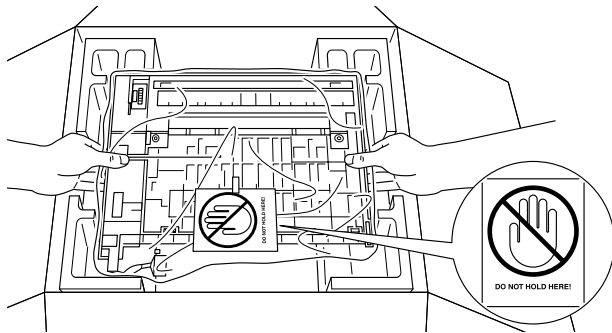

3. Remove the cover and the Duplex Unit connector cover on the side of the printer as shown below.

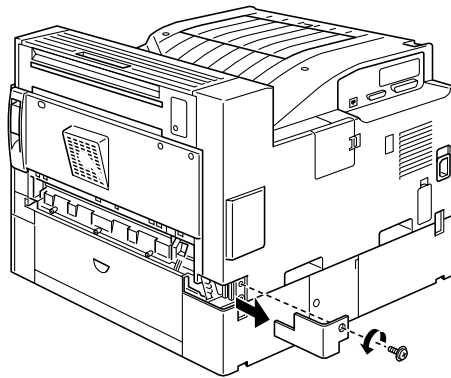
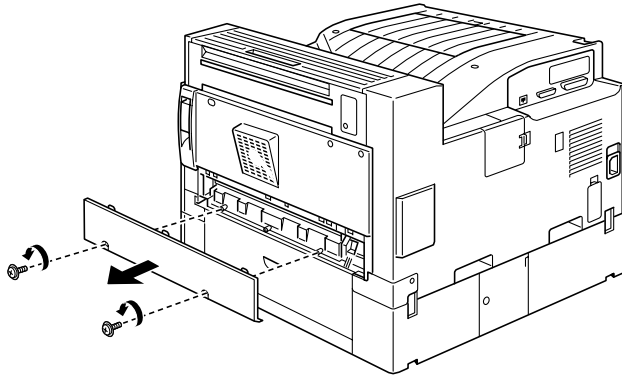



4. Insert the paper transfer unit as shown below.

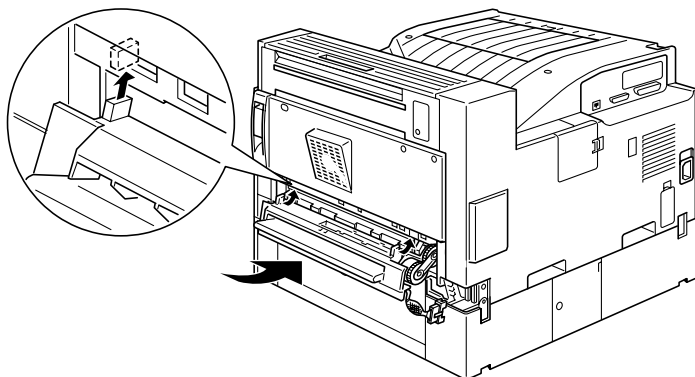

5. Fasten the paper transfer unit with the included screws.

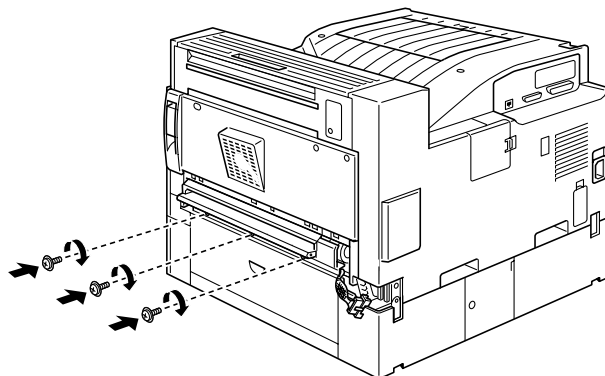

6. Connect the cable on the right side of the paper transfer unit to the connector on the printer.

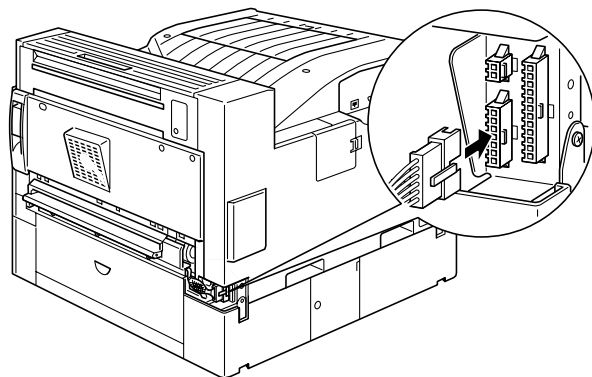

7. Remove the covers shown below.

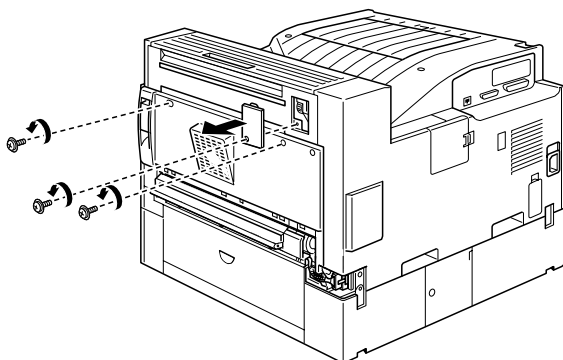

8. Hold the Duplex Unit at an angle and insert the two tabs at the base of the unit into the slots (marked with arrows) on the printer. Push to attach the upper portion of the unit onto the printer.

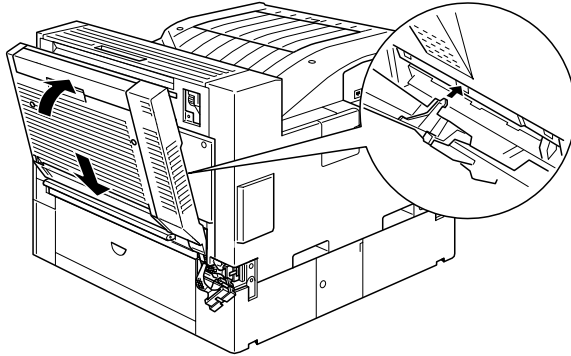

9. Fasten the screws as shown below. (The screws are already inside the Duplex Unit.)

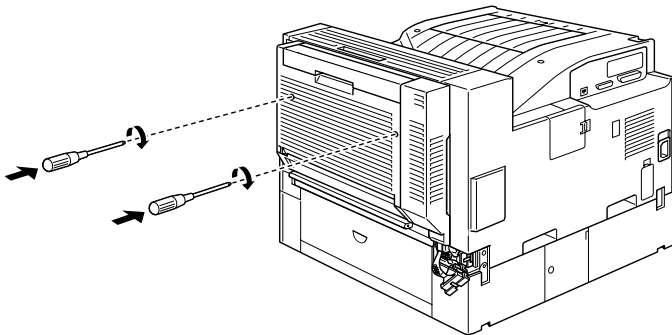

10. Remove the protective cover from the cable attached to the Duplex Unit, then plug the ends of the cable into the appropriate connectors at the side of the printer.

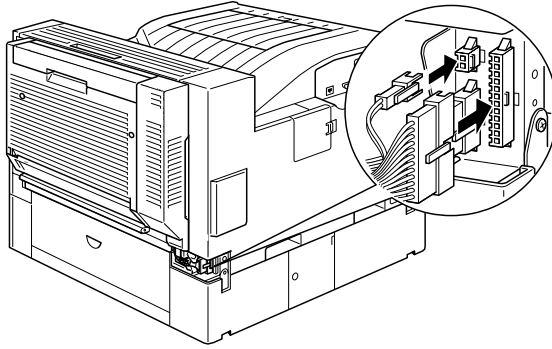

11. Replace the connector cover and fasten the screw.

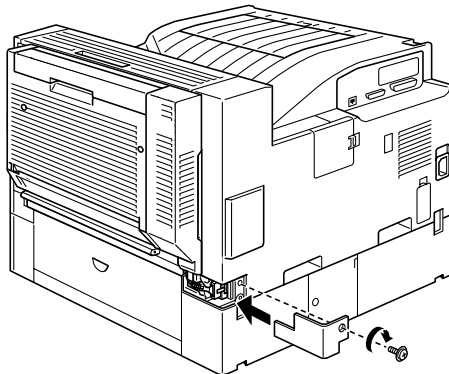

12. After you install the Duplex Unit, slide the tether tension lever to the position shown below.

**Note:**

*Be sure you close the cover of the Duplex Unit before you adjust the tether.*

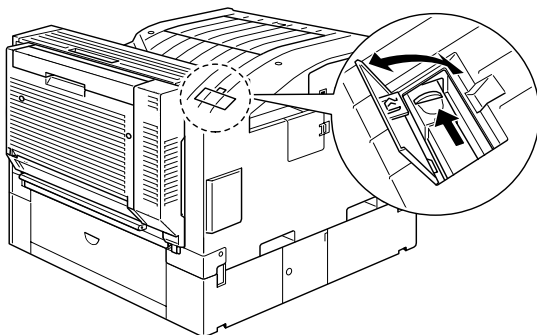

---

## **Hard Disk Drive**

Installing the optional Hard Disk Drive (C82377\*) allows you to print complex and large print jobs at high speed.

Follow these steps to install the optional Hard Disk Drive:

**Note:**

*The installation procedure below assumes that you have not yet installed an optional 5-Bin or 10-Bin Multi-Purpose Unit onto the printer. If either or both of the units are installed, you have to first remove them. For instructions, see the Reference Guide.*

1. Make sure the printer is not turned on, and unplug the power cord if it is plugged into an electrical outlet.



**Warning:**

*To avoid electrical shock, do not attempt to install a Hard Disk Drive unless the printer is turned off.*

2. Open the top cover of the face-down tray.

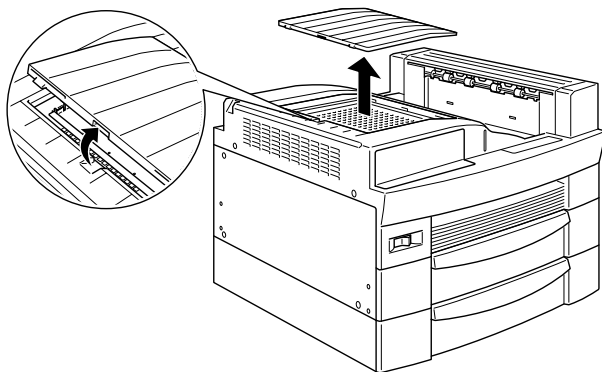

3. Loosen the two retaining screws and remove the plate.

**Note:**

*To avoid losing the retaining screws, do not remove them completely from the plate.*

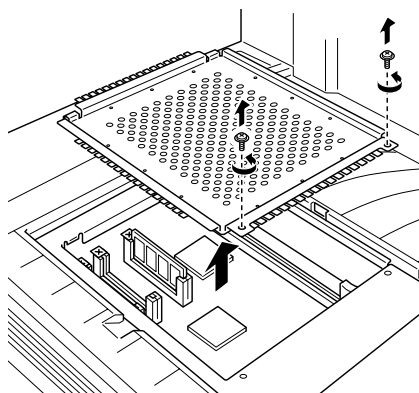

**Warning:**

*Avoid touching electrical components that are exposed after you remove the plate. They may be very hot if the printer has been in use.*

4. Identify the Hard Disk Drive socket. Its relative location is as shown below.

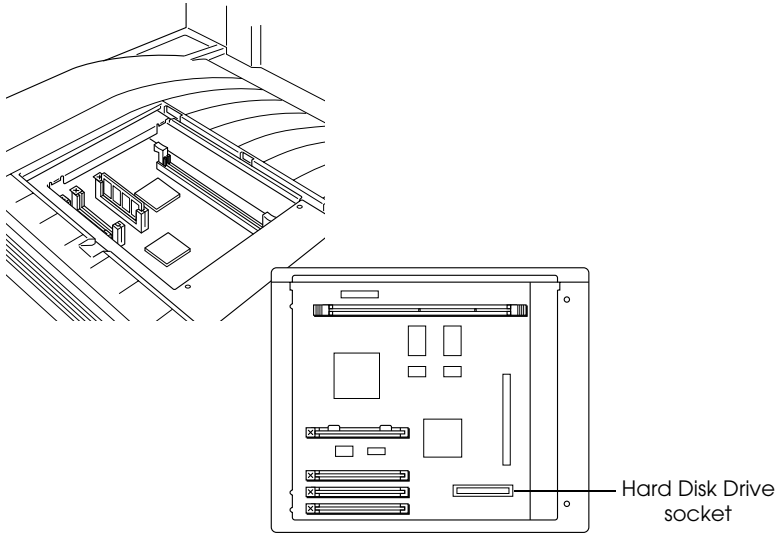

5. Unpack the Hard Disk Drive.
6. Hold the Hard Disk Drive such that its electrical connector is on the same side as the socket on the circuit board.

7. Lower and attach the drive into the circuit board, making sure the connector is securely fastened into the socket.

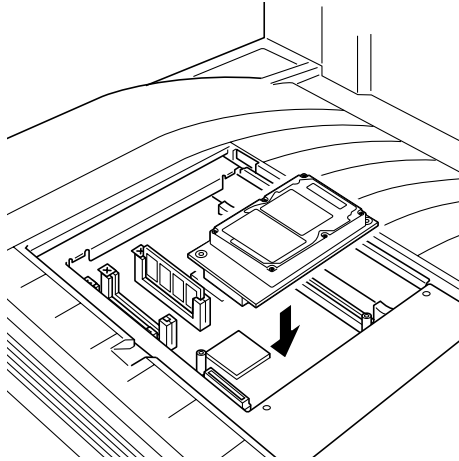

8. Fasten the two screws provided in the positions illustrated below.

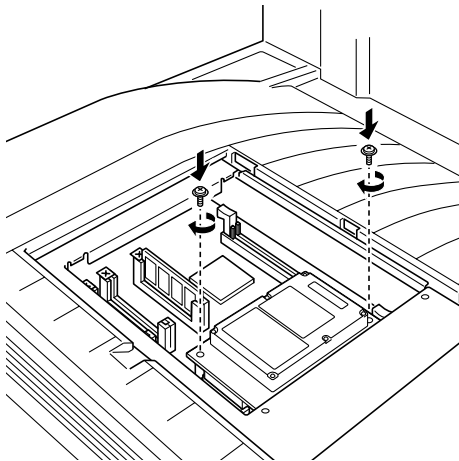



- Return the plate to its original position. Place the two outside tabs of the plate under the edge of the opening with the inside tabs on top of the edge.

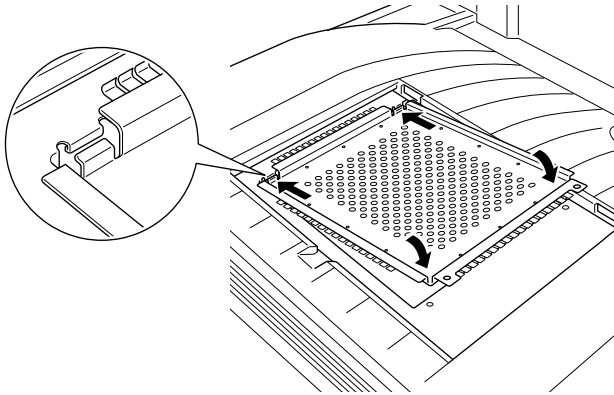

- Push the plate down into place. Then fasten the two retaining screws that you loosened earlier.

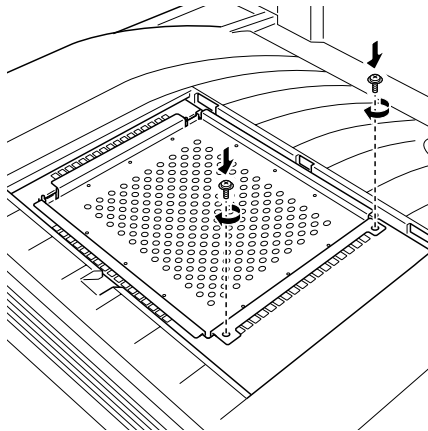

11. Gently replace the top cover until it clicks shut.

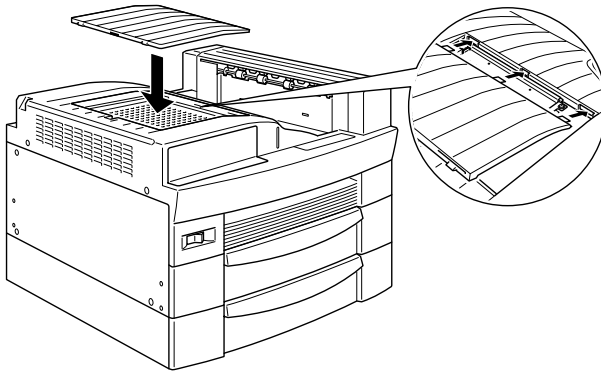

---

## **Memory Module**

The printer comes with 16 MB of memory. By installing an optional Dual In-line Memory Module (DIMM), you can increase printer memory up to a maximum of 256 MB. You may want to add memory if you are having difficulty printing complex, graphics-intensive pages using one of the optional multibin units with the duplex feature, or if you regularly use numerous downloaded fonts.

You can purchase DIMMs from various vendors. Be sure the DIMM you purchase meets the following requirements:

- Synchronous Dynamic RAM Dual In-line Memory Module (SDRAM DIMM)
- 64 bit, 168-pin type, with SPD
- Capacity of 16, 32, 64, 128, or 256 MB
- Access speed of 66.66 MHz or higher (15 ns or less)
- Less than 40 mm in height

Follow these steps to install an optional memory module:

**Note:**

*The installation procedure below assumes that you have not yet installed an optional 5-Bin or 10-Bin Multi-Purpose Unit onto the printer. If either or both of the units are installed, you have to first remove them. For instructions, see the Reference Guide.*

1. Make sure the printer is not turned on, and unplug the power cord if it is plugged into an electrical outlet.



**Warning:**

*To avoid electrical shock, do not attempt to install a memory module unless the printer is turned off.*

2. Open the top cover of the face-down tray.

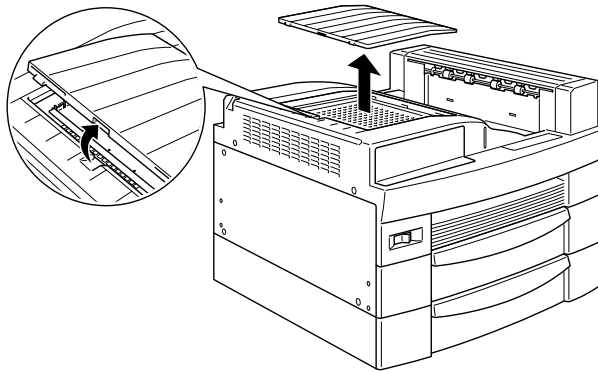

3. Loosen the two retaining screws and remove the plate.

**Note:**

*To avoid losing the retaining screws, do not remove them completely from the plate.*

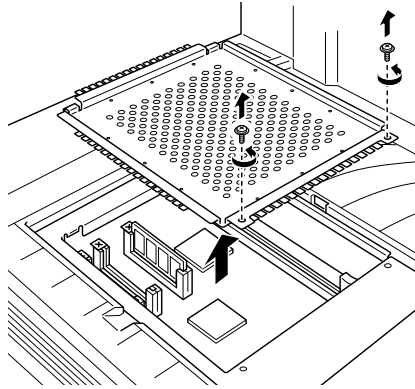

**Warning:**

*Avoid touching electrical components that are exposed after you remove the plate. They may be very hot if the printer has been in use.*

4. Identify the DIMM slot. Its relative location is as shown below.

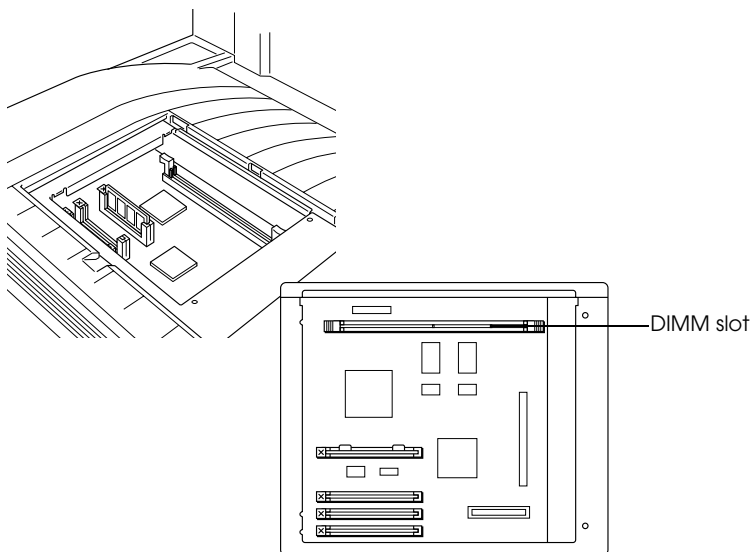

5. Pull the clips on each side of the DIMM slot outward.

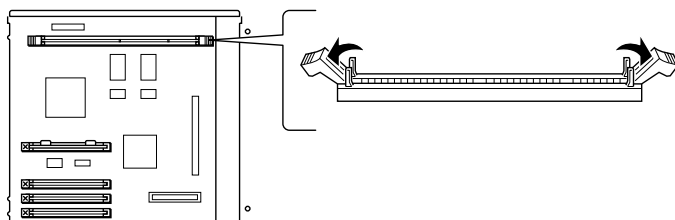

6. Hold the memory module above the DIMM slot in the following orientation, then insert it into the slot. Do not apply too much force.

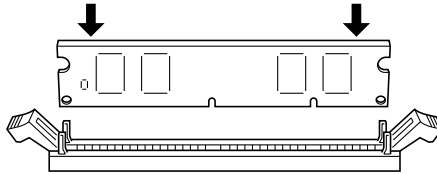

7. Push one end of the DIMM into the slot until the clip comes up.

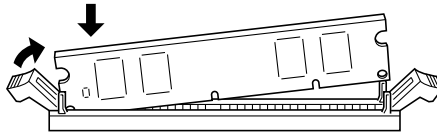

8. With your other hand, push down the other end of the DIMM into the slot until the clip comes up to retain the memory module securely.

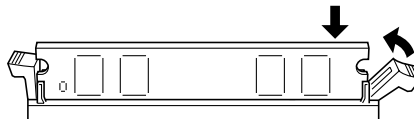

- Return the plate to its original position. Place the two outside tabs of the plate under the edge of the opening with the inside tabs on top of the edge.

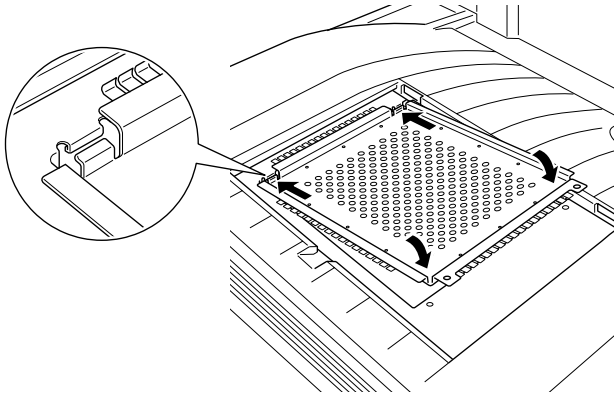

- Push the plate down into place. Then fasten the two retaining screws that you loosened earlier.

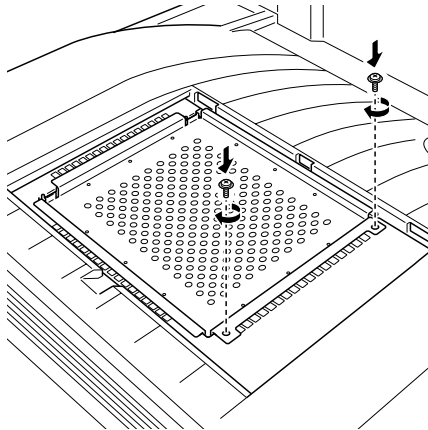

11. Gently replace the top cover until it clicks shut.

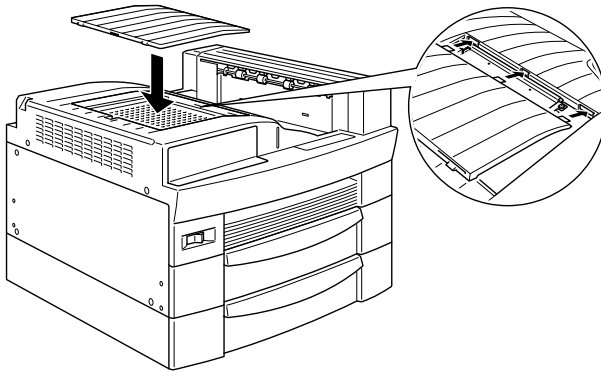

---

## **Adobe PostScript 3 ROM Module**

The Adobe<sup>®</sup> PostScript<sup>®</sup> 3<sup>™</sup> Kit (C83241\*) ROM module generates crisp PostScript output.

Follow these steps to install the optional Adobe PostScript 3 ROM module:

**Note:**

*The installation procedure below assumes that you have not yet installed an optional 5-Bin or 10-Bin Multi-Purpose Unit onto the printer. If either or both of the units are installed, you have to first remove them. For instructions, see the Reference Guide.*

1. Make sure the printer is not turned on, and unplug the power cord if it is plugged into an electrical outlet.



**Warning:**

*To avoid electrical shock, do not attempt to install a ROM module unless the printer is turned off.*



2. Open the top cover of the face-down tray.

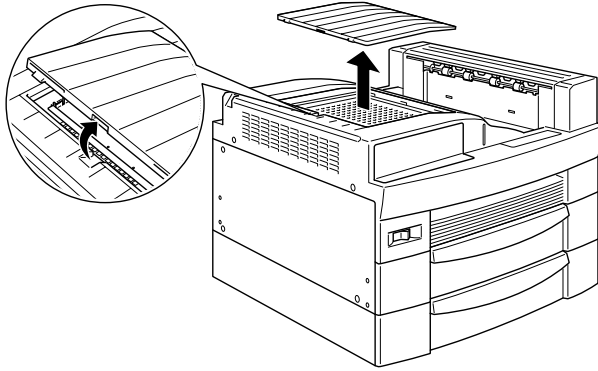

3. Loosen the two retaining screws and remove the plate.

**Note:**

*To avoid losing the retaining screws, do not remove them completely from the plate.*

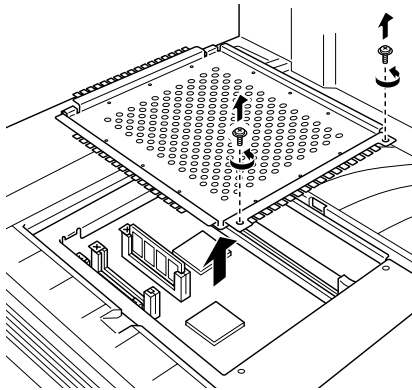

**Warning:**

*Avoid touching electrical components that are exposed after you remove the plate. They may be very hot if the printer has been in use.*

4. Identify the slots for ROM modules. Their relative locations are as shown below.

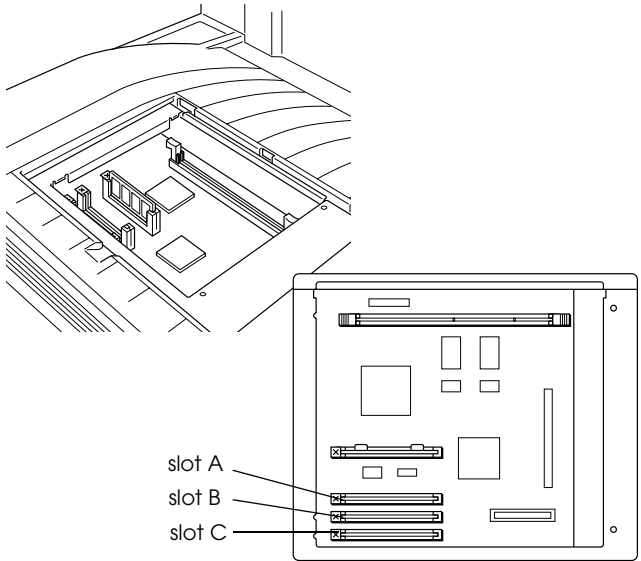

5. Hold the ROM module in the following orientation, then insert the ROM module into slot A.

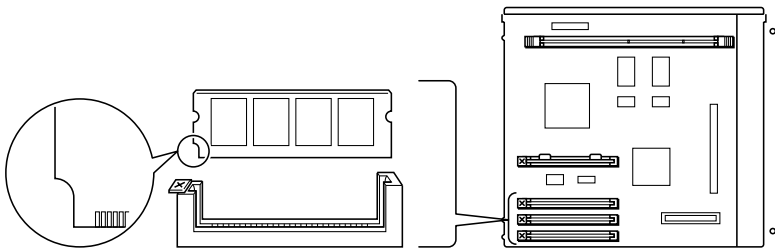

6. Push the ROM module into the slot evenly until the button comes up.

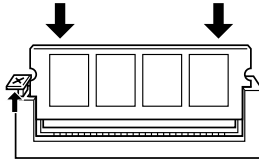

7. Return the plate to its original position. Place the two outside tabs of the plate under the edge of the opening with the inside tabs on top of the edge.

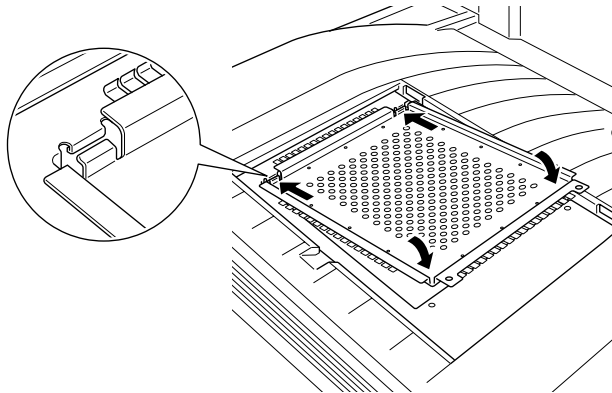

8. Push the plate down into place. Then fasten the two retaining screws that you loosened earlier.

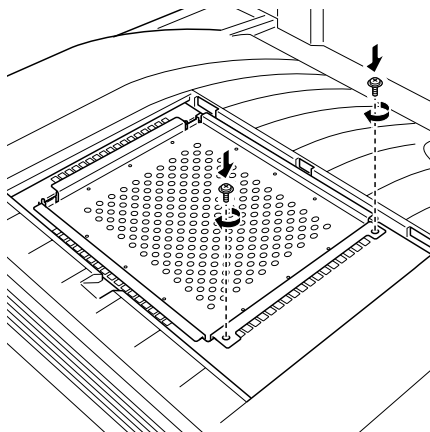

9. Gently replace the top cover until it clicks shut.

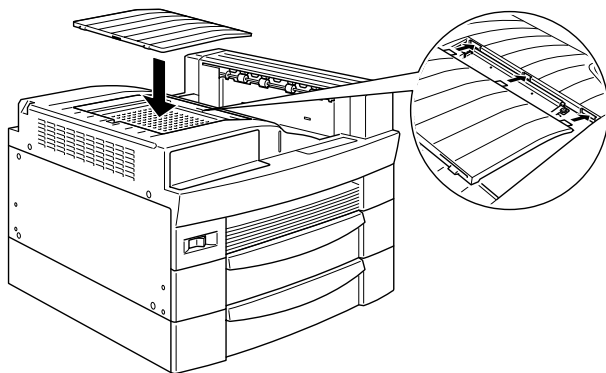

---

## Interface Card

A variety of optional interface cards are available to provide additional links between your printer and computers or networks. See the *Reference Guide* or a complete list of available optional interface cards.

Follow these steps to install an optional interface card:

1. Face the back of the printer.
2. Remove the two screws that secure the interface slot cover and remove the cover.

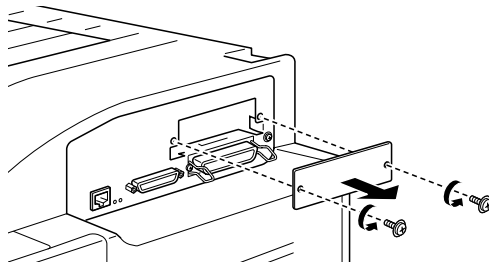

3. With the component side of the optional interface card facing up, slide the interface card into the grooves of the interface slot as shown below. Push the card firmly to lock it into place.

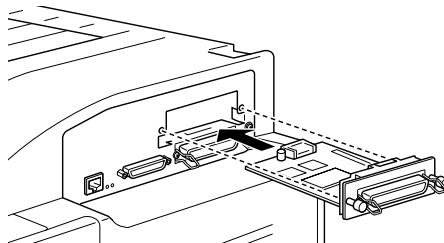

4. Secure the interface card by fastening the two retaining screws.

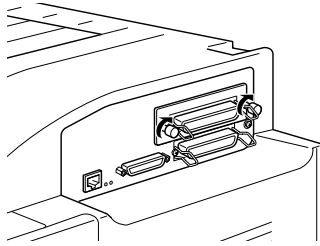

---

## **5-Bin Multi-Purpose Unit**

The optional 5-Bin Multi-Purpose Unit (C81320\*) can be used as a mailbox, a sorter, a multiple sorter, or a large capacity stacker. The output capacity is 500 printed sheets of plain paper.

Follow these steps to install the optional 5-Bin Multi-Purpose Unit:

1. Open the shipping carton.
2. Remove the inserts and all other protective materials inside the box. Make sure the contents of the package match the items on the included documentation. Remove the packaging materials and any other items from the unit and store them for future use.

3. Remove the printer covers, as shown below.

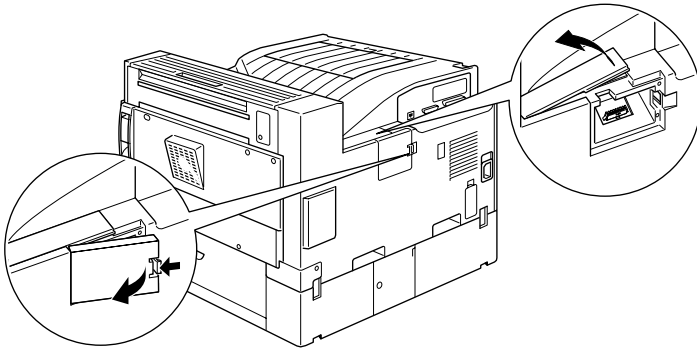

4. Place the unit on top of the printer. Be careful not to drop the unit.

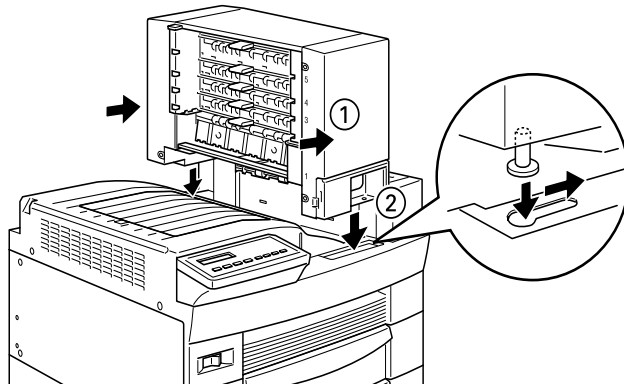

5. Fasten the screw on the front of the unit.

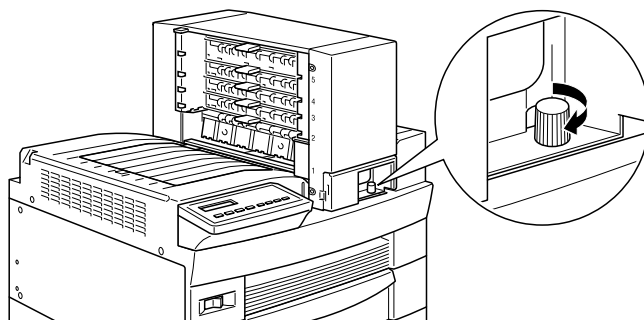

6. Fasten the screw on the back of the unit, then attach the cable to the connector on the back of the printer.

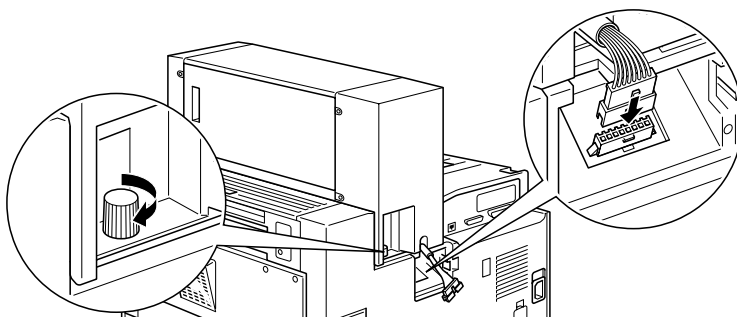



7. Attach the covers as shown below.

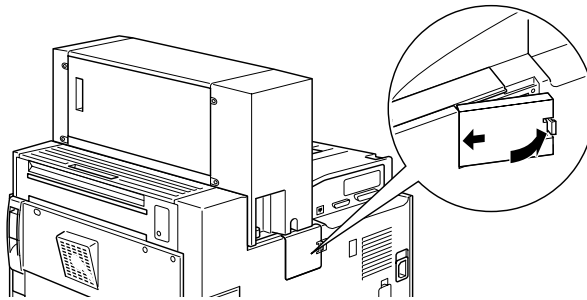
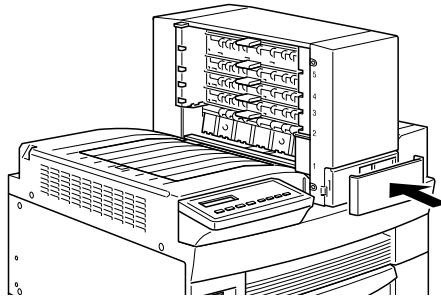

8. Insert the tray shown below into Bin 1. (The tray has the number 1 printed on the top right corner). Please note that this tray differs in shape from the trays for the other bins.

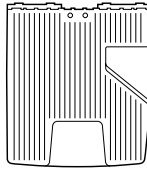

top

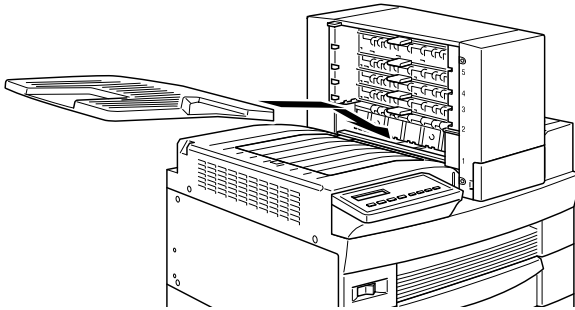

9. Insert the trays shown below into Bins 2 to 4, starting from the bottom. (These trays are numbered from 2 to 4). Please note that these trays differ in shape from the trays for Bins 1 and 5.

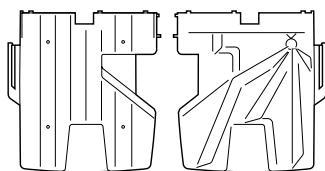

top

bottom

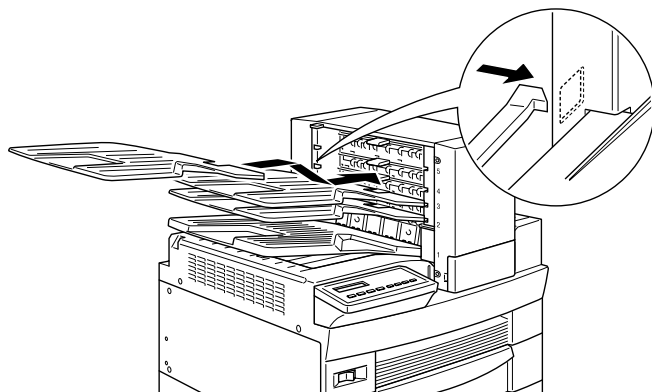

10. Insert the tray shown below into Bin 5. (The tray has the number 5 printed on the top right corner). Please note that the this tray differs in shape from the trays for the other bins.

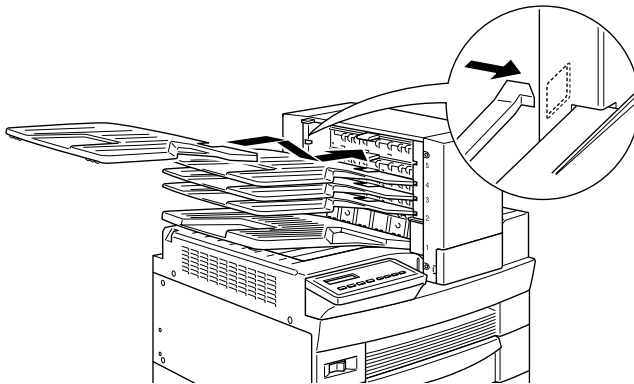
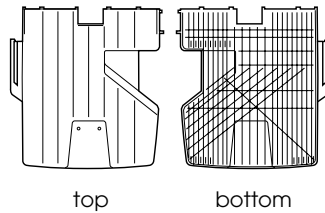

11. Open the back cover of the unit and remove all protective materials.

---

## ***10-Bin Multi-Purpose Unit***

The optional 10-Bin Multi-Purpose Unit (C81321\*) can be used as a mailbox, a sorter, a multiple sorter, or a large capacity stacker. The output capacity is 2,000 printed sheets of plain paper.

Follow these steps to install the optional 10-Bin Multi-Purpose Unit:

1. Open the shipping carton.
2. Unpack the unit from the top and remove the contents.

**Note:**

*The 10-Bin Multi-Purpose Unit itself is heavy, so you will need the assistance of at least one person to lift the inner box containing the unit out of the carton, and to remove the unit from the inner box.*

3. Attach the two metal plates to the left side of the printer with the included fittings and screws, as shown below.

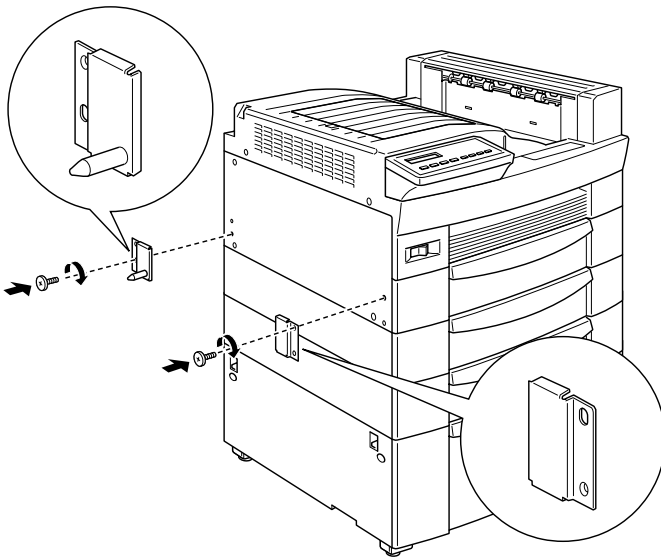

4. Attach the lower support clamp to the bottom of the printer as shown. Press up on the clamp until it clicks into place.

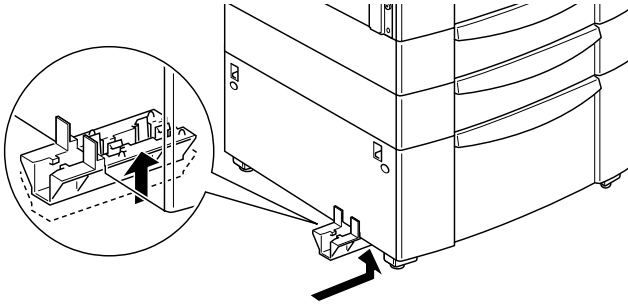

5. Open the cover on the back side of the 10-Bin Multi-Purpose Unit and remove the protective materials inside.

6. Insert one end of the lower support bar into the lower support clamp on the printer and the other end into the lower support clamp on the 10-Bin Multi-Purpose Unit.

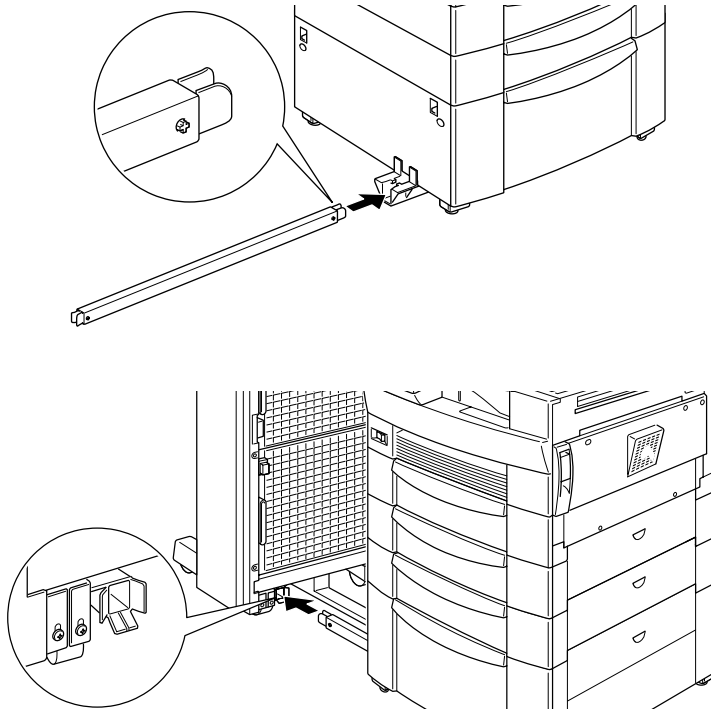

Then roll the 10-Bin Multi-Purpose Unit toward the printer until the magnets on the unit make contact with the metal plates.

7. Tighten the screw at the bottom of the unit to secure the lower support bar.

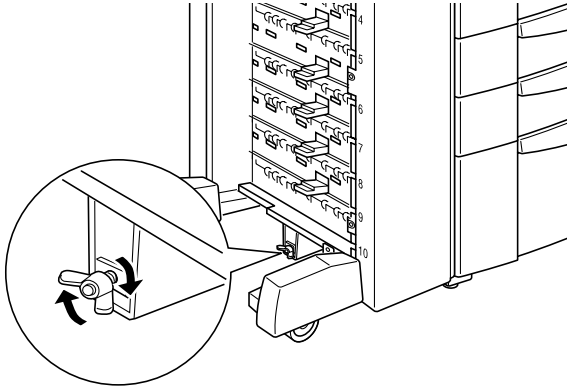

8. Remove the stickers from the holes on the face-down tray, then attach the lower paper guide as shown below.

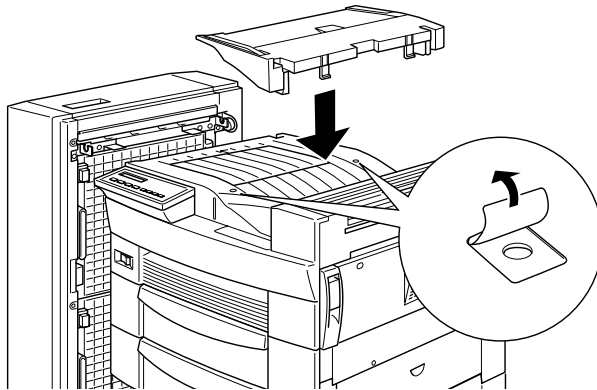



9. Open the upper paper guide cover, then insert the front of the upper paper guide into the opening on the lower paper guide and lower the guide onto the hooks on the 10-Bin Multi-Purpose Unit. Tighten the screws on both sides of the paper guide, then close the upper paper guide cover.

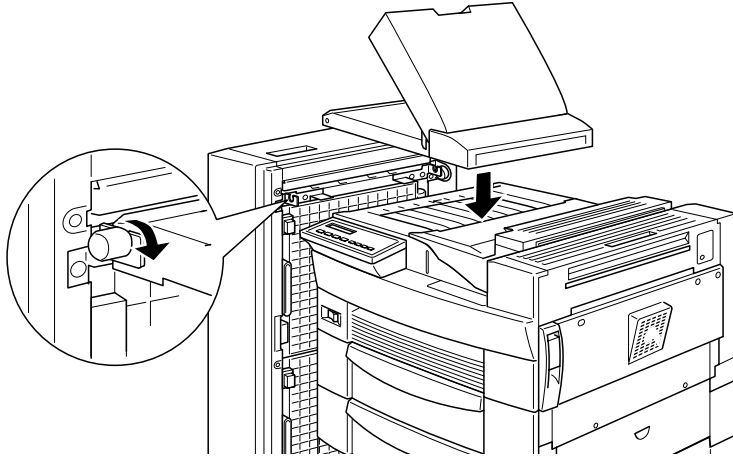

10. Attach the cables from the 10-Bin Multi-Purpose Unit to the printer and the paper guide as shown below.

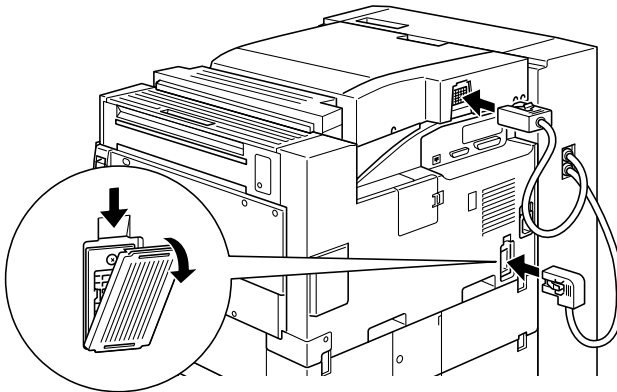

11. Insert the output trays into the unit, starting from the bottom. All the trays are of the same shape.

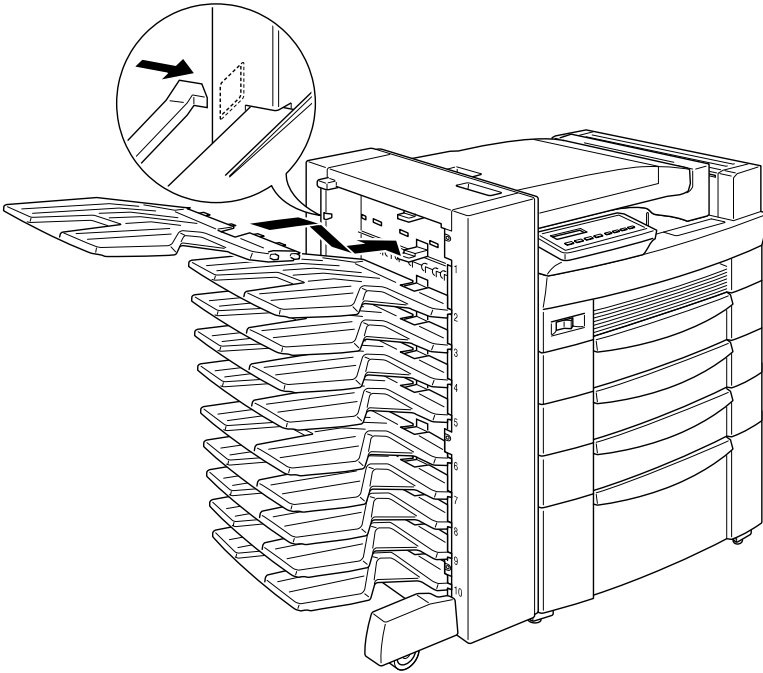

12. If you need to adjust the height of the unit, remove the cover on the front wheel first, then turn the front screws to the left. Turn the top screw to adjust the height of the unit, then turn the front screws to the right to secure the top screw. Replace the front wheel cover.

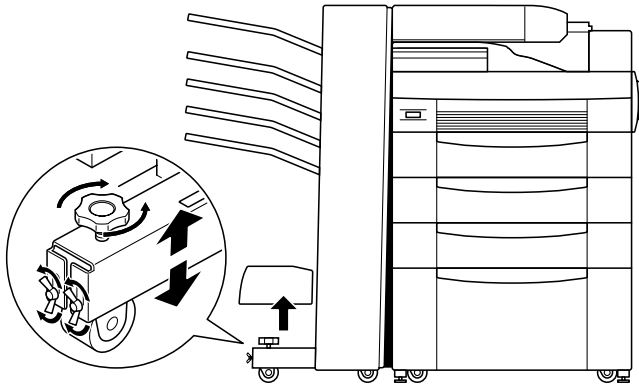

---

# 4

## Plugging in the Printer

---

---

### Attaching the Power Cord

Follow these steps to plug the printer into an electrical outlet:

1. Make sure the power switch on the front of the printer is turned off.
2. Insert the power cord into the AC inlet at the back of the printer, then plug the other end into a properly grounded outlet.

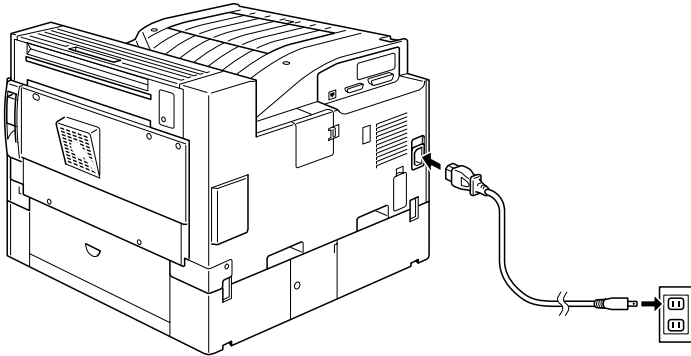

**Caution:**

- Avoid using outlets that other appliances are plugged into.
- Only use an outlet that meets the power requirements of this printer.

---

## Loading Paper

This section provides you with instructions for loading paper into the MP tray and the standard lower cassette.

**Note:**

*The printer also supports an optional 500-Sheet Lower Cassette Unit, which uses the same loading method as the standard lower cassette.*

### Loading paper into the MP tray

The MP tray can accommodate various types and sizes of paper and envelopes. It handles 250 sheets of plain paper, allowing you to load a total of 750 sheets when used in combination with the lower cassette.

You can load the following paper sizes. The loading orientation differs depending on the paper size, as explained below:

Loading Orientation	Paper Size
Vertical	A4, A5, Executive, Letter, B5, G-Letter, HLT
Horizontal	A3, Ledger, Legal, B4, F4, G-Legal, Monarch, Commercial 10, DL, C5, C6, International B5

**Note:**

*When you load Executive, G-Letter, HLT, Ledger, B4, G-Legal, and other custom paper sizes, select the paper size in the printer driver, then set the paper size for the MP tray using the SelecType Tray Menu. For instructions, see “SelecType Settings” in the Reference Guide.*

Follow these steps to load paper into the MP tray:

1. Pull out the paper cassette and remove the protective materials inside.

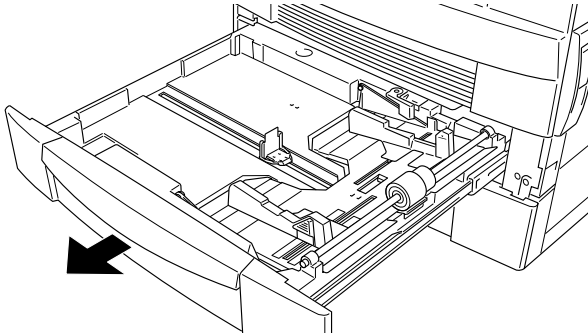

2. Push down the inner tray until it clicks onto the bottom of the cassette.

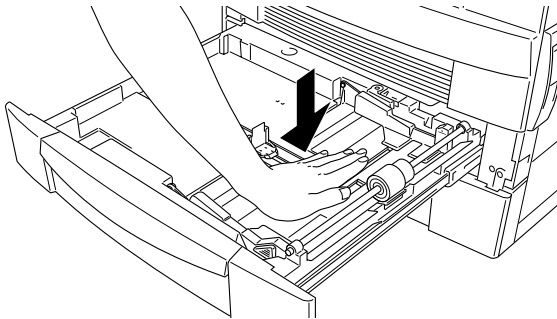

3. While pressing the vertical and horizontal paper guides, pull them up and slide them outward to accommodate the paper you are loading.

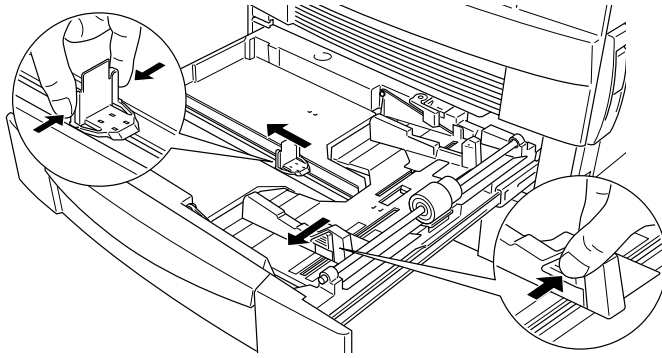

4. Fan a stack of paper and tap it on a flat surface to even the edges, then insert the paper into the cassette with the printable side facing up.

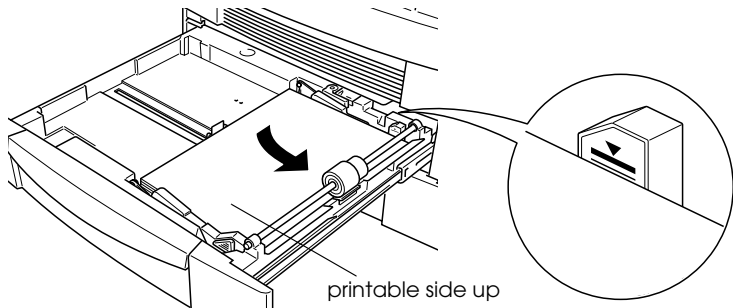

**Note:**

- Be sure not to load paper higher than the maximum paper mark.
- If your printouts are curled or do not stack properly when using plain paper, try turning the stack over and reloading it.

5. Adjust the vertical and horizontal paper guides to match the size of your paper.

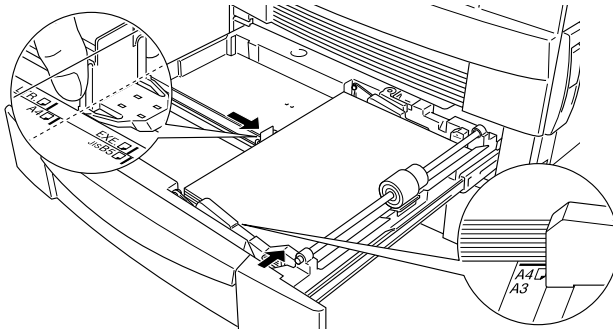

**Note:**

*Make sure to adjust the paper guides to the paper size you load; otherwise, the printer will not print properly.*

6. Push the paper cassette in.

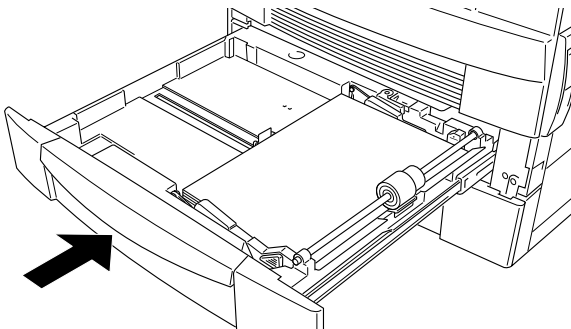



7. Peel the appropriate paper size label from the label sheet included with your printer and attach it to the outside of the MP tray.

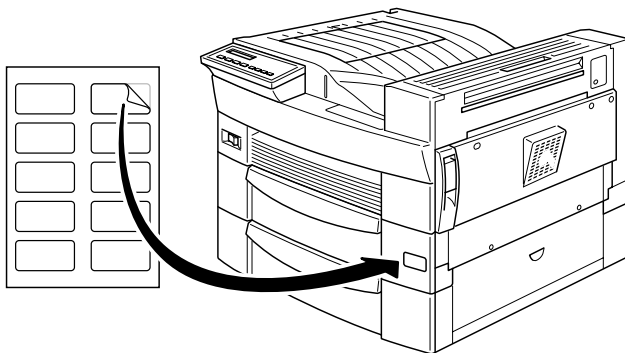

### ***Loading paper into the lower cassette***

The lower cassette can accommodate a variety of paper sizes. It handles 500 sheets of plain paper, allowing you to load a total of 750 sheets when used in combination with the MP tray.

You can load the following paper sizes. The loading orientation differs depending on the paper size, as explained below:

<b>Loading Orientation</b>	<b>Paper Size</b>
Vertical	A4, Letter, Government Letter
Horizontal	A3, Ledger, Legal, B4

Follow these steps to load paper into the lower cassette, or into an optional 500-Sheet Lower Cassette Unit:

1. Pull the paper cassette all the way out, and remove the protective materials inside.

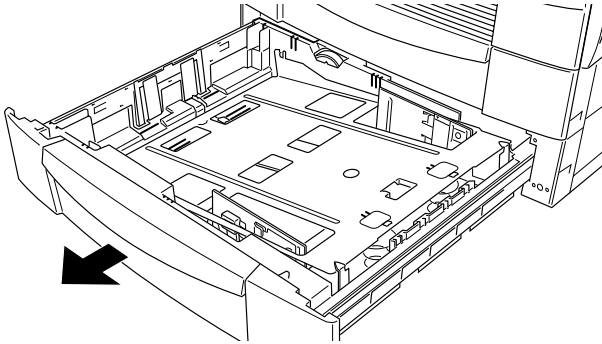

2. Push down the inner tray until it clicks onto the bottom of the cassette.

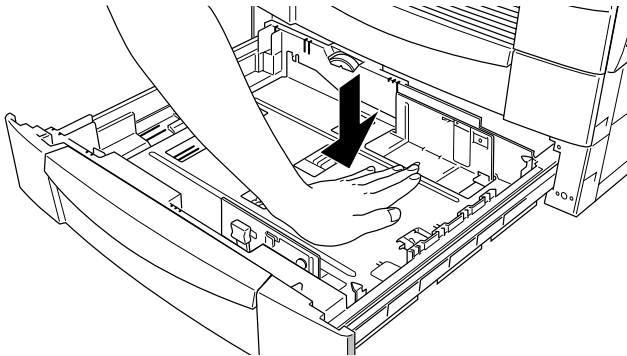

3. While pressing the vertical paper guide, pull it up and slide it outward to accommodate the paper you are loading.

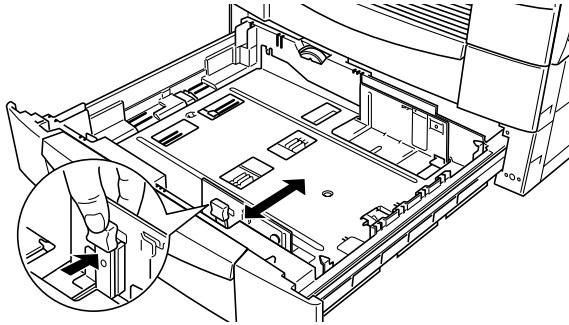

4. Insert the horizontal paper guide into the slot for the paper size you want to load.

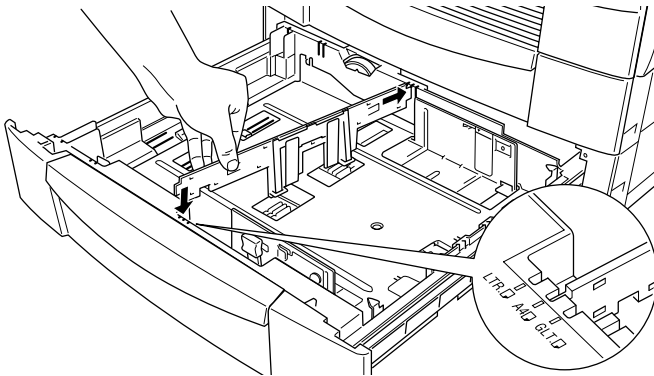

5. Fan a stack of paper and tap it on a flat surface to even the edges. Insert the paper with the printable side facing up, aligning the corners of the paper with the metal retaining clips inside the cassette.

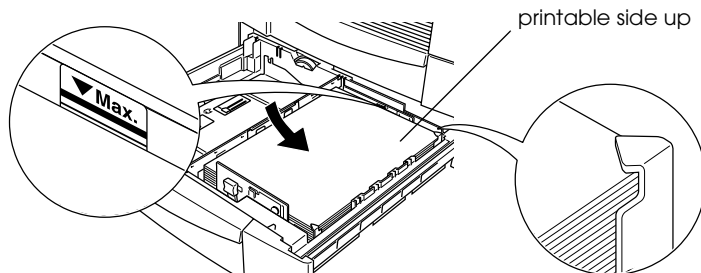

**Note:**

- ❑ Be sure not to load paper higher than the maximum paper mark.
  - ❑ If your printouts are curled or do not stack properly when using plain paper, try turning the stack over and reloading it.
  - ❑ Make sure to adjust the paper guides to match the paper size you load; otherwise, the printer will not print properly.
6. Set the paper size with the paper-size dial.

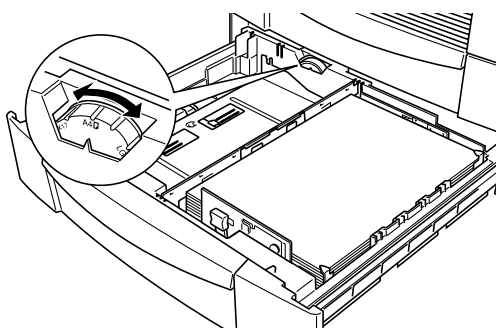

7. Push the paper cassette in.

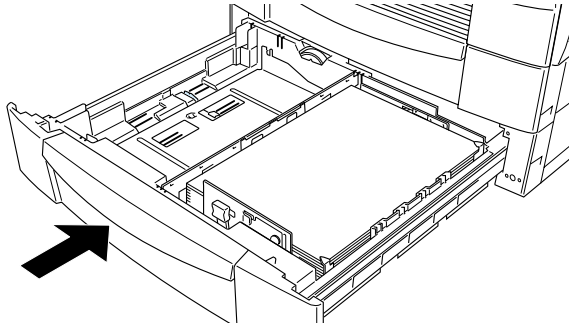

8. Peel the appropriate paper size label from the label sheet included with your printer and attach it to the outside of the cassette.

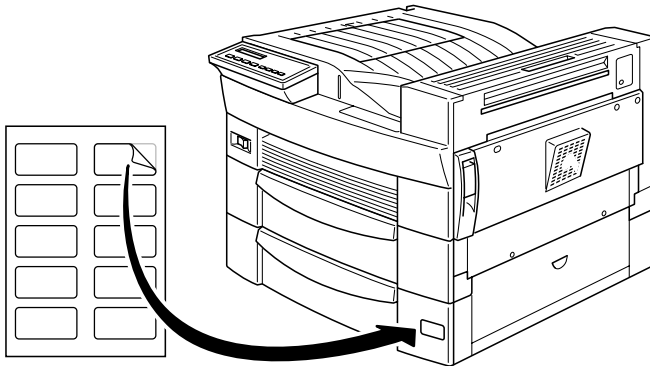

## **Selecting the paper size**

By default, the printer driver is set for A4 size paper. If you load paper of a different size, change the Paper Size setting on the printer driver's Basic Settings tab. For more information on using the printer driver, see the driver's online help.

You can also change this setting from the printer's control panel by using OneTouch mode 1. For details, see "Using the OneTouch Modes" in the *Reference Guide*.

---

## **Testing the Printer**

To test if the printer is properly set up, print a status sheet. You can print a status sheet directly by using the SelecType menus on the printer's control panel. The status sheet contains information on the current printer settings and all installed options. Printing a status sheet is an effective way of testing the printer because it eliminates the possibility of connection problems with the computer.

## **Printing a status sheet**

Follow these steps to print a status sheet from the control panel:

1. Make sure the imaging cartridge is installed.
2. Make sure that paper is loaded into the printer.

3. Turn on the printer. Several messages will appear on the LCD panel as the printer performs internal tests. After about 10 seconds, the Ready message will appear.

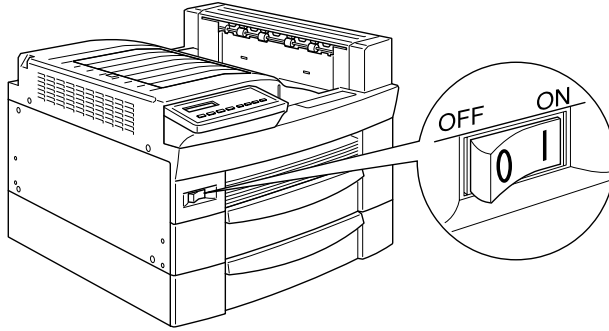

4. Make sure the On Line light is on. This indicates that the printer is ready to accept and print data. If it isn't on, press the On Line button.
5. Press Enter two times. The printer will print the status sheet, showing the current printer settings.

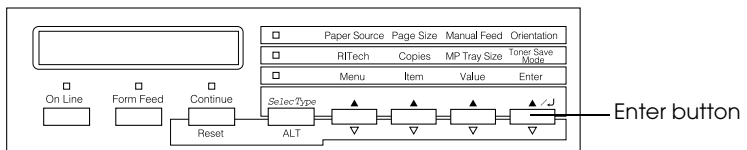

---

## Connecting the Printer to a Computer

Although this printer is intended to be used on a network, you can use the parallel interface to connect the printer directly to a computer.

**Note:**

*Your printer also has room for an optional interface. See Chapter 4, "Using Options," in your Reference Guide for more information.*

Follow these steps to connect the printer to your computer through the parallel interface:

1. Make sure both the printer and the computer are turned off.
2. Connect the parallel cable to the parallel interface connector on the printer.

**Note:**

*Use only a shielded, twisted-pair parallel cable.*

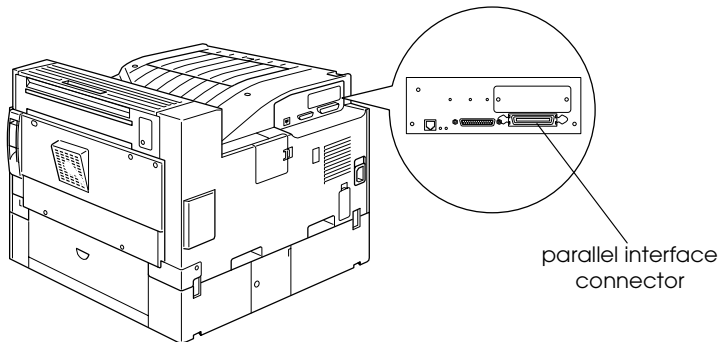



- Secure the connector by pushing the two wire clips together until they lock into place on both sides of the connector. If your cable has a ground wire, connect it to the printer's ground connector as shown below.

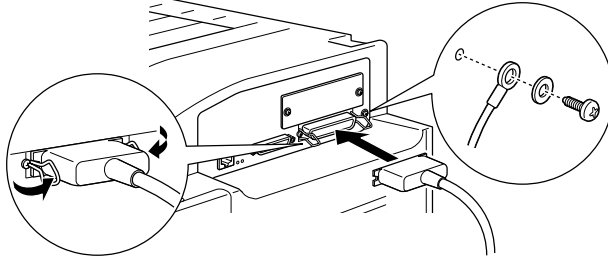

- Connect the other end of the cable to your computer, and fasten it as required. If the cable has a ground wire at the computer end, attach it to the ground connector at the back of the computer.
- Turn on the printer, then turn on your computer.

# 5

## System Requirements

---

To use your printer with a PC, you need Microsoft® Windows® 98/95/3.1, Windows 2000, or Windows NT® 4.0/3.51.

To install and use the printer software (printer driver and utilities) included on the CD-ROM or floppy disk packed with your printer, your system should meet the following requirements:

Component	Minimum system	Recommended system
CPU	i486/25 MHz for Windows 95/3.1, or NT 4.0/3.51  i486/66 MHz for Windows 98  Pentium 133 MHz for Windows 2000	Pentium or higher processor for Windows 98/95, or NT 4.0  Higher than Pentium 133 MHz for Windows 2000
RAM	16 MB RAM for Windows 98/95/3.1, or NT 4.0/3.51  32 MB RAM for Windows 2000	32 MB RAM or more for Windows 98/95/3.1, or NT 3.51  64 MB RAM or more for Windows 2000, or NT 4.0
Hard disk space	10 MB free hard disk space for Windows 98/95/3.1  20 MB free hard disk space for Windows 2000, or NT 4.0/3.51	50 MB or more free disk space for Windows 98/95/3.1, or NT 3.51  100 MB or more free disk space for Windows 2000, or NT 4.0
Display	800 x 600 pixel monitor	Greater than 800 x 600 pixel monitor, with High Color (16 bit) or True Color (32 bit) setting
Web browser	Microsoft Internet Explorer 4.0	Later than Internet Explorer 4.0

# 6

---

## *For DOS Programs*

---

Since DOS application programs differ in their driver selection procedures, there is no standard way to select the printer driver. See your software manual for information on how to select the printer.

When asked to select a printer, pick the first printer available in the list below.

- EPL-N2750
- EPL-N2700
- EPL-N4000
- EPL-5500/5500+
- EPL-N1200
- EPL-5600
- EPL-3000
- EPL-5200/5200+
- HP LaserJet 4L
- HP LaserJet 4

If you choose a printer other than the EPL-N2750, you may not be able to use some printer features.

---

## **What to do Next**

After completing the hardware setup and the driver installation, see the *Reference Guide* for detailed information about your printer's functions, maintenance, troubleshooting, technical specifications and optional products.

---

## **Using the Online Guide**

The online guide contains detailed instructions on how to use the printer, and provides you with information on installing and using optional products. You can view this guide directly from the CD-ROM, or install it into your computer and view it from your hard disk.

**Note:**

*Microsoft Internet Explorer 4.0 or later, or Netscape Navigator 4.0 or later, must be installed in your computer to read the online guide.*

See "System Requirements" on page 76 for information on the system requirements necessary for installing and using the online guide.

---

# 8

## Safety Information

---

---

### ENERGY STAR Compliance



As an ENERGY STAR Partner, EPSON has determined that this product meets the ENERGY STAR guidelines for energy efficiency.

The International ENERGY STAR Office Equipment Program is a voluntary partnership with the computer and office equipment industry to promote the introduction of energy-efficient personal computers, monitors, printers, fax machines, copiers, and scanners, in an effort to reduce air pollution caused by power generation.

---

### Ozone Safety

#### *Ozone emission*

Ozone gas is generated by laser printers as a by-product of the printing process. Ozone is produced only when the printer is printing.

#### *Ozone exposure limit*

The recommended exposure limit for ozone is 0.02 parts per million (ppm) expressed as an average time-weighted concentration over an eight-hour period.

The EPL-N2750 laser printer generates less than 0.01 ppm for eight hours of continuous printing in a closed room of approximately 1000 cubic feet (8' × 10' × 12').

### *Minimize exposure risk*

To minimize the risk of exposure to ozone:

- Do not use more than one laser printer in a confined area.
- Do not use your printer in conditions of extremely low humidity.
- Do not use your printer in a room with poor ventilation.
- Avoid long, continuous printing in any of the conditions mentioned above.

### *Printer location*

The printer should be located so that the exhaust gases and generated heat are:

- Not blown directly into the user's face.
- Vented directly out of the building whenever possible.

---

## ***Laser Safety***

This printer is certified as a Class 1 laser product under the U.S. Department of Health and Human Services (DHHS) Radiation Performance Standard according to the Radiation Control for Health and Safety Act of 1968. This means that the printer does not produce hazardous laser radiation.

Since radiation emitted by the laser is completely confined within protective housings and external covers, the laser beam cannot escape from the machine during any phase of user operation.

## **For European users**

### *United Kingdom*

The EPL-N2750 is a page printer which utilizes a semiconductor laser.

There is no possibility of danger from the laser, provided the printer is operated according to the instructions in the guides provided.

Since radiation emitted by the laser is completely confined within protective housings, the laser beam cannot escape from the machine during any phase of user operation.



**Warning:**

*The use of controls, or the performance of procedures and adjustments other than those specified in this guide may result in hazardous radiation exposure.*

This is a semiconductor laser. The maximum power of the laser diode is 5 mW and the wavelength is 775 to 795 nm.

## **CDRH regulations**

The Center for Devices and Radiological Health (CDRH) of the U.S. Food and Drug Administration implemented regulations for laser products on August 2, 1976. Compliance is mandatory for products marketed in the United States. The label shown below indicates compliance with the CDRH regulations and must be attached to laser products marketed in the United States.

This laser product conforms to the applicable  
requirement of 21 CFR  
Chapter I, subchapter J.  
SEIKO EPSON CORP.  
Hirooka Office  
80 Hirooka, Shiojiri-shi, Nagano-ken,  
Japan  
MANUFACTURED:

## Laser safety labels



### **Warning:**

*The use of controls, or the performance of procedures and adjustments other than those specified in this guide may result in hazardous radiation exposure.*

Your printer is a Class 1 laser product as defined in IEC 825 specifications. The label shown below is attached in countries where required.



## Internal laser radiation

Max. Radiation Power      5 mW

Wave Length                      775 to 795 nm

This is a Class IIIb Laser Diode Assembly that has an invisible laser beam. The printer head unit is NOT A FIELD SERVICE ITEM. Therefore, the printer head unit should not be opened under any circumstances.

---

## For United Kingdom Users

### Use of options

Epson (UK) Limited shall not be liable against any damages or problems arising from the use of any options or consumable products other than those designated as Original EPSON Products or EPSON Approved Products by Epson (UK) Limited.



## Safety information

**Warning:** *This appliance must be earthed. Refer to rating plate for voltage and check that the appliance voltage corresponds to the supply voltage.*

**Important:** *The wires in the mains lead fitted to this appliance are coloured in accordance with the following code:*

*Green and yellow—Earth*

*Blue—Neutral*

*Brown—Live*

**If you need to fit a plug:**

*As the colours of the mains lead of this appliance may not match any coloured markings used to identify the terminals in a plug, please proceed as follows:*

- The green and yellow wire must be connected to the terminal in the plug which is marked with the letter *E* or the Earth symbol ( $\perp$ ).
- The blue wire must be connected to the terminal in the plug marked with the letter *N*.
- The brown wire must be connected to the terminal in the plug marked with the letter *L*.

If damage occurs to the plug, replace the cord set or consult a qualified electrician.

Replace fuses only with a fuse of the correct size and rating.



---

# Index

---

## **Numerics**

- 10-Bin Multi-Purpose Unit, 54
- 500-Sheet Lower Cassette Unit, 13
- 5-Bin Multi-Purpose Unit, 48

## **A**

- Assembling the printer, 6

## **C**

- Connecting
  - power cord, 62
  - printer to computer, 74

## **D**

- DOS programs, 77
- Duplex Unit, 25

## **H**

- Hard Disk Drive, 31

## **I**

- Imaging cartridge, 8
- Installing
  - 10-Bin Multi-Purpose Unit, 54
  - 500-Sheet Lower Cassette Unit, 13
  - 5-Bin Multi-Purpose Unit, 48
  - Adobe PostScript 3 ROM module, 42
  - Duplex Unit, 25
  - Hard Disk Drive, 31
  - imaging cartridge, 8
  - interface cards, 47
  - Large Capacity Paper Unit, 18
  - memory module, 36
- Interface cards, 47

## **L**

- Large Capacity Paper Unit, 18
- Loading paper, 63
  - lower cassette, 67
  - MP tray, 63
- Lower cassette, 67

## **M**

- Memory module, 36
- MP tray, 63

## **O**

- Online guide, using, 78
- Options
  - 10-Bin Multi-Purpose Unit, 54
  - 500-Sheet Lower Cassette Unit, 13
  - 5-Bin Multi-Purpose Unit, 48
  - Adobe PostScript 3 ROM module, 42
  - Duplex Unit, 25
  - Hard Disk Drive, 31
  - installing, 13
  - interface cards, 47
  - Large Capacity Paper Unit, 18
  - memory module, 36

## **P**

- Paper size, selecting, 72
- Paper sizes, supported
  - lower cassette, 67
  - MP tray, 63
- PostScript 3 ROM module, Adobe, 42
- Power cord, attaching, 62

## **Q**

- Quick reference box, attaching, 6

## **S**

### Safety

- CDRH regulations, 81
- ENERGY STAR Compliance, 79
- internal laser radiation, 82
- labels, 82
- laser, 80
- laser printer precautions, 1
- ozone, 79
- read before using, 3
- Warnings, Cautions, and Notes, 5

Side cover, attaching, 7

Status sheet, printing, 72

System requirements, 76

# EPSON

Laser Printer

EPSON EPL-N2750

## *Setup Guide*

Printed in Japan  
00.XX-XX