

EPSON

Laser Printer

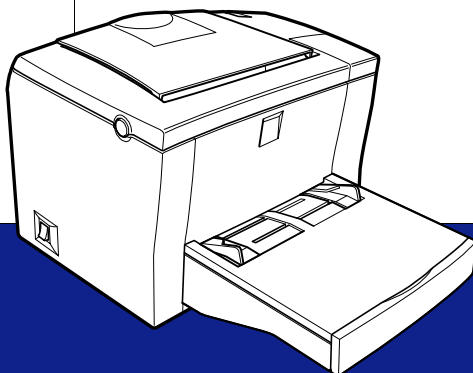

EPSON EPL-5800L

Reference Guide

EPSON®

Laser Printer

EPL-5800L

All rights reserved. No part of this publication may be reproduced, stored in a retrieval system, or transmitted in any form or by any means, mechanical, photocopying, recording, or otherwise, without the prior written permission of SEIKO EPSON CORPORATION. No patent liability is assumed with respect to the use of the information contained herein. Neither is any liability assumed for damages resulting from the use of the information contained herein.

Neither SEIKO EPSON CORPORATION nor its affiliates shall be liable to the purchaser of this product or third parties for damages, losses, costs, or expenses incurred by purchaser or third parties as a result of: accident, misuse, or abuse of this product or unauthorized modifications, repairs, or alterations to this product, or (excluding the U.S.) failure to strictly comply with SEIKO EPSON CORPORATION's operating and maintenance instructions.

SEIKO EPSON CORPORATION shall not be liable against any damages or problems arising from the use of any options or any consumable products other than those designated as Original Epson Products or Epson Approved Products by SEIKO EPSON CORPORATION.

General Notice: Other product names used herein are for identification purposes only and may be trademarks of their respective owners. EPSON disclaims any and all rights in those marks.

Copyright © 2000 by SEIKO EPSON CORPORATION, Nagano, Japan

Contents

Getting Started

About This Guide	7
Warnings, Cautions, and Notes	8
Safety Precautions	9
Power On/Off Cautions	12

Chapter 1 Product Information

Printer Parts	14
Panel lights	15
About Your Printer	16
Features	16
Options and consumable products	17

Chapter 2 Paper Handling

Available Media	19
Paper that should not be used	20
Paper Sources	21
MP tray	21
500-Sheet Lower Paper Cassette Unit	21
Loading Paper	22
MP tray	22
Manually loading paper	26
500-Sheet Lower Paper Cassette Unit	27
Printing on Special Media	28
Envelopes	29
Labels	30
Transparencies	30
Thick paper	31

Chapter 3 Using the Printer Driver

Using the Printer Driver with Windows	33
Accessing the printer driver	33
EPSON Status Monitor 3 Utility	34
Increasing the Printing Speed	43
Note for using shared printers in Windows 2000 and NT 4.0	44
Choosing the printer port	49
Using Printer Driver with Macintosh	55
Accessing the printer driver	55
EPSON Status Monitor 3 Utility	55

Chapter 4 Installing and Removing Options

Printer Options	61
500-Sheet Lower Paper Cassette Unit	62
Installing	62
Removing	63
Face-up Tray	64
Installing	65
Using	66
Removing	66
Memory Module	67
Installing	67
Removing	72

Chapter 5 Replacing Consumables

Replacing the Developer Cartridge	77
Replacing the Photoconductor Unit	82

Chapter 6 Troubleshooting

Ready and Error Lights	88
Problems and Solutions	89
Preventing paper-feed and paper-jam problems	89
Clearing paper jams	90
Operational problems	100
Printout problems	101
Print quality problems	102
Memory problems	107
Option problems	108
Printer driver and utility problems	109
Communication errors	110

Chapter 7 Cleaning and Transporting the Printer

Cleaning the Printer	113
Cleaning the inside of the printer	113
Removing spilled toner	115
Cleaning the printer case	116
Transporting the Printer	117

Appendix A Technical Specifications

Paper	119
Specifications	119
Printer	121
General	121
Environmental	122
Safety approvals	122
Mechanical	123
Electrical	123
Interface	124
Parallel interface	124
USB interface	124

Options and Consumables	125
500-Sheet Lower Paper Cassette Unit (C81336*).....	125
Face-up Tray (C813372)	126
Developer cartridge (S050010)	126
Photoconductor unit (S051055).....	127

Appendix B Working with Fonts

EPSON BarCode Fonts	129
System requirements	130
Installing EPSON BarCode fonts	131
Printing with EPSON BarCode fonts.....	133
BarCode Font specifications	136

Appendix C Contacting Customer Support

For Users in the United Kingdom and the Republic of Ireland.....	150
For Users in Australia	151
For Users in Singapore	153
For Users in Hong Kong.....	154
For Users in Malaysia	155
For users in India	155
For Users in the Philippines	156

Glossary

Index

Getting Started

Your EPSON EPL-5800L Advanced printer combines high performance and reliability with a wide range of features.

To get started with your printer, please:

- ❑ Read the safety information, laser printer precautions, and important safety instructions in the *Setup Guide*.
- ❑ Use your *Setup Guide* to set up and test your new printer.

See this *Reference Guide* for detailed information about your printer.

About This Guide

This guide contains information about using your printer. For information about installing and setting up the printer, see the *Setup Guide*.

Chapter 1, “Product Information,” introduces the printer’s parts and features, and options. It explains how to operate the printer. It also contains information on how to optimize print quality.

Chapter 2, “Paper Handling,” tells you what special paper and media is available for your printer, plus how to load and print on it.

Chapter 3, “Using the Printer Driver,” gives you the information about the print quality settings and information about the software that comes with the printer.

Chapter 4, “Installing and Removing Options,” gives step-by-step instructions for installing and removing printer options.

Chapter 5, “Replacing Consumables,” explains how to replace consumable products

Chapter 6, “Troubleshooting,” tells you what to do if you encounter problems.

Chapter 7, “Cleaning and Transporting the Printer,” provides instructions on how to clean and transport your printer.

Appendix A, “Technical Specifications,” contains the technical specifications for the printer.

Appendix B, “Working with Fonts,” describes the steps you need to follow to add EPSON BarCode fonts. It also lists and shows samples of the available fonts.

Appendix C, “Contacting Customer Support,” contains customer support information.

Warnings, Cautions, and Notes



Warnings must be followed carefully to avoid bodily injury.



Cautions must be observed to avoid damage to your equipment.

Notes contain important information and useful tips about the operation of your printer.

Safety Precautions

Be sure to follow these precautions carefully to ensure safe, efficient operation:

- ❑ Be careful not to touch the fuser, which is marked **CAUTION Hot Surface Avoid Contact**, or the surrounding areas. If the printer has been in use, the fuser and the surrounding areas may be very hot.

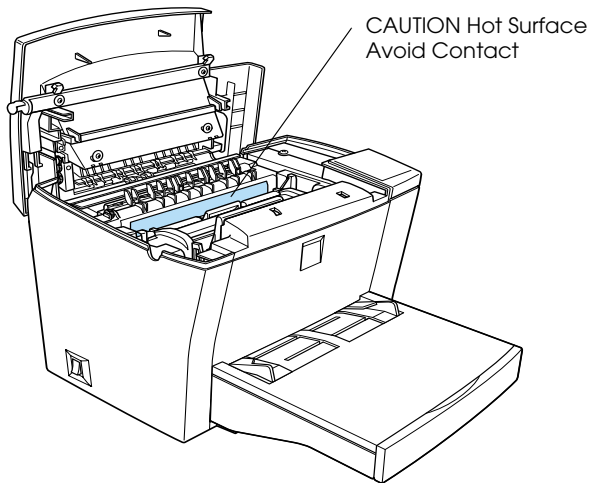

- ❑ Avoid touching the components inside the printer unless instructed to do so in this guide.
- ❑ Never force printer components into place. Although the printer is designed to be sturdy, rough handling can damage it.

- ❑ When removing the developer cartridge, never touch the developing roller under the flap; otherwise, print quality will decline.

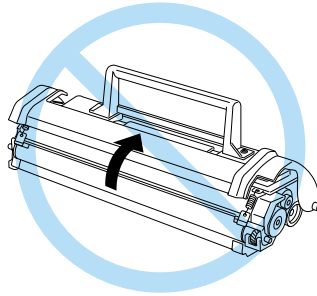

- ❑ Do not turn the cartridge upside down or stand it on its ends.
- ❑ When handling the cartridge, always place it on a clean, smooth surface.
- ❑ Do not attempt to modify the cartridge or take it apart. It cannot be refilled.
- ❑ Avoid touching the toner or getting it in your eyes.

- ❑ When removing or installing a photoconductor unit, protect the light-sensitive drum from exposure to light any longer than necessary. The light-sensitive drum is the green cylinder visible through the openings in the unit. Overexposing the drum might cause abnormally dark or light areas to appear on the printed page and may shorten the service life of the unit.

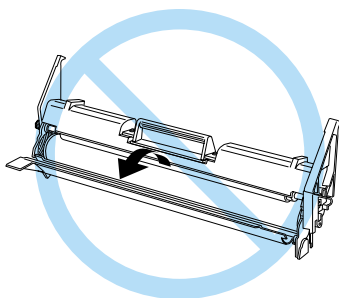

- ❑ Be careful not to scratch the surface of the drum. When you remove the photoconductor unit from the printer, always place the unit on a clean, smooth surface. Avoid touching the drum, since oils from your skin can permanently damage its surface and affect print quality.
- ❑ To get the best print quality, do not store the photoconductor unit in an area subject to direct sunlight, dust, salt air, or corrosive gases (such as ammonia). Avoid locations subject to extreme or rapid changes in temperature or humidity.
- ❑ Wait for at least one hour before using a developer cartridge or a photoconductor unit after moving it from a cool to a warm environment to prevent damage from condensation.



Warning:

Do not dispose of used developer cartridges or photoconductor units in fire, as they can explode and cause injury. Dispose of them according to local regulations.

- ❑ Be sure to keep the consumable components out of the reach of children.
- ❑ Do not leave jammed paper in the printer. It can cause the printer to overheat.
- ❑ Avoid using outlets that other appliances are plugged into.
- ❑ Use only an outlet that meets the power requirements of this printer.

Power On/Off Cautions



Caution:

Do not turn off the printer:

- ❑ *For at least 22 seconds after turning on the printer. Wait until the Ready (green) light comes on and is not flashing.*
- ❑ *While the Ready (green) light is flashing.*
- ❑ *While printing.*

Chapter 1

Product Information

Printer Parts	14
Panel lights.....	15
About Your Printer	16
Features	16
Options and consumable products	17

Printer Parts

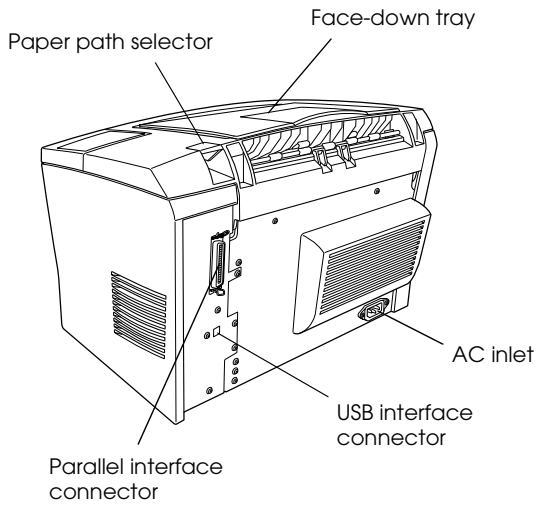
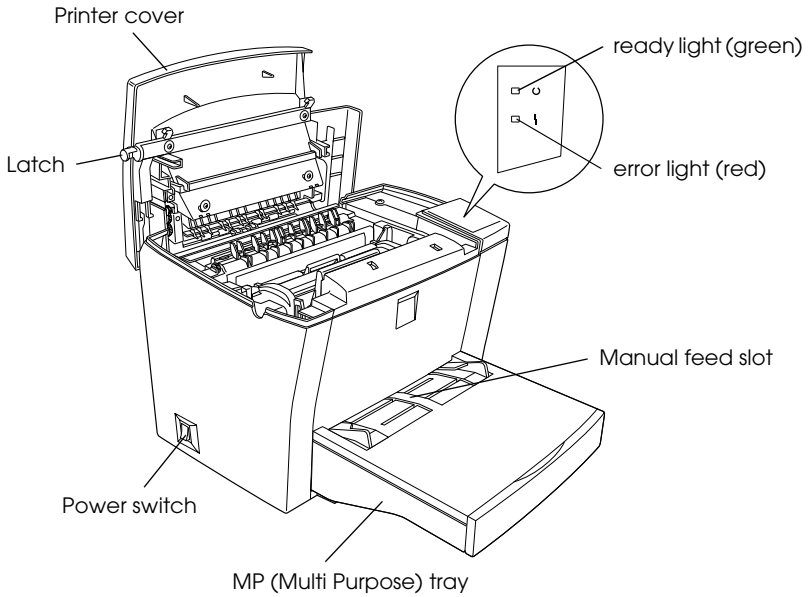

Panel lights

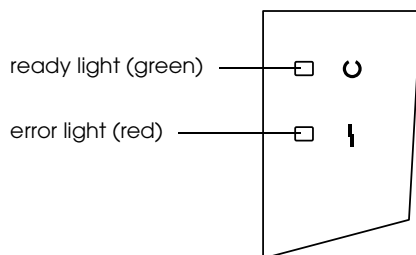

Ready Light (green)	Error Light (red)	Printer Status
Off	Off	Printer is off.
On	Off	Printer is ready to print.
Flashing	Off	Printer is warming up or receiving data.
Off	Flashing	The printer is out of paper or has an error that can be easily cleared. See "Problems and Solutions" on page 89.
Flashing	On	
Off	On	An error has occurred. Try turning off the printer, waiting a few minutes and then turning it back on. If this does not clear the error, contact your dealer or a qualified service person.
Flashing alternately.		

About Your Printer

Your printer is the latest in EPSON's advanced line of laser printers.

The printer's 600/300-dpi (dots per inch) resolution is enhanced by EPSON's Resolution Improvement Technology (RITech) and Enhanced MicroGray technology. RITech works by smoothing out the jagged edges of diagonal and curved lines in both text and graphics, while Enhanced MicroGray improves the halftone quality of graphics.

The printer is easy to install and use. You simply set up the printer, connect it to your computer, and install the printer driver as described in the *Setup Guide*.

The printer supports ECP mode in Microsoft® Windows® Me, 98, 95, 2000, and NT® 4.0. ECP mode supports high-speed data transfer and bi-directional communication with your computer.

Features

The printer comes with a full set of features that enhance ease of use and provide consistent, high-quality output. The main features are described below.

High-quality printing

Your printer provides 600-dpi/300-dpi printing at a speed of up to 10 pages per minute. You'll appreciate the professional print quality produced by your printer and its quick processing speed.

Toner Save mode

To reduce the amount of toner used in printing documents, you can print drafts using the Toner Save mode.

Options and consumable products

Options and consumable products are sold separately, and can be installed easily. To purchase options or consumable products, contact your dealer or the customer support representative in your area. The last digit of the product number, represented by an asterisk (*), varies by country. Be sure to mention the product number when placing your order.

Memory

The printer comes with 2 MB of memory, which can be expanded up to a total of 13 MB.

500-Sheet Lower Paper Cassette Unit (C81336)*

This unit installs onto the bottom of the printer. It automatically feeds up to 500 sheets of paper without reloading, and serves as a second paper source to your printer. Depending on the country of purchase, the unit takes either A4 or Letter-size paper.

Face-up Tray (C813372)

The Face-up Tray is recommended for printing on media that require a straight-through paper path, such as labels and transparencies.

Developer Cartridge

This cartridge includes the toner that creates the image on paper. The printer comes with this cartridge already installed. The service life of the cartridge is approximately 6,000 printed pages.

Photoconductor Unit

The photoconductor unit contains a light-sensitive drum that permanently fixes the toner onto paper. The printer comes with this unit already installed. This unit requires replacement after approximately 20,000 pages of printing.

Chapter 2

Paper Handling

Available Media	19
Paper that should not be used.	20
Paper Sources	21
MP tray	21
500-Sheet Lower Paper Cassette Unit	21
Loading Paper	22
MP tray	22
Manually loading paper.	26
500-Sheet Lower Paper Cassette Unit	27
Printing on Special Media.	28
Envelopes	29
Labels	30
Transparencies.	30
Thick paper	31

Available Media

This section explains what kinds of paper and media you can use with your printer. Do not use paper or media not mentioned in this section.

Note:

The printer is extremely sensitive to moisture. Be sure to store your paper in a dry environment.

Paper Type	Description
Plain paper	Recycled paper is acceptable* Weight: 60 to 90 g/m ² (16 to 24 lb)
Envelopes	No paste and no tape No plastic window (unless specifically designed for laser printers)
Labels	The backing sheet should be covered completely, with no gaps between labels**
Thick paper	Weight: 90 to 163 g/m ² (24 to 43.4 lb)
Colored paper	Non-coated
Letterhead	Paper with preprinted letterhead, provided that the paper and ink are both compatible with laser printers. Paper which printed with laser printer, ink Jet printer, or other printers cannot be used.

* Use recycled paper only under normal temperature and humidity conditions. Poor quality paper may reduce print quality, cause paper jams and other problems.

** Gaps between labels may cause the labels to peel off inside the printer and damage the printer.

Note:

Since the quality of any particular brand or type of media may be changed by the manufacturer at any time, EPSON cannot guarantee the quality of any type of media. Always test samples of media stock before purchasing large quantities or printing large jobs.

Paper that should not be used

You cannot use the following paper in this printer. They may cause printer damage, paper jams, and poor print quality.

- Media meant for other color laser printers, black-and-white laser printers, color copiers, black-and-white copiers, or ink jet printers
- Previously printed paper from any other color laser printer, black-and-white laser printer, color copier, black-and-white copier, ink jet printer, or thermal transfer printer
- Carbon paper, no-carbon paper, thermal-sensitive paper, pressure-sensitive paper, acid paper, or paper that uses high-temperature-sensitive ink (around 190° C)
- Labels that peel easily or labels that do not cover the backing sheet completely
- Coated paper or special surface-colored paper
- Paper that has binder holes or is perforated
- Paper that has glue, staples, paper clips, or tape on it
- Paper that attracts static electricity
- Moist or damp paper
- Paper of uneven thickness
- Overly thick or thin paper
- Paper that is too smooth or too rough
- Paper that is different on the front and back
- Paper that is folded, curled, wavy, or torn
- Paper of irregular shape, or paper that does not have right angle corners

Paper Sources

This section describes the combinations of paper sources and paper types that you can use.

MP tray

Paper Type	Capacity	Paper Size
Plain paper	Up to 150 sheets of 75 g/m ² paper (Weight: 60 to 90 g/m ²)	A4, A5, B5, Letter (LT), Legal (LGL), F4, Half-Letter (HLT), Executive (EXE), Government Letter (GLT), Government Legal (GLG), Custom-size paper: 76.2 × 127 mm minimum 215.9 × 355.6 mm maximum
Letterhead		
Labels	Up to 10 sheets (Weight: 90 to 163 g/m ²)	
Thick paper		
Transparencies		
Envelopes	Up to 10 sheets (Weight: 60 to 90 g/m ²)	Monarch (MON), Commercial 10 (C10), DL, C6, C5, International B5

500-Sheet Lower Paper Cassette Unit

Paper Type	Capacity	Paper Size
Plain paper	Up to 500 sheets	A4 or Letter, depending on the country of purchase
Letterhead		

Loading Paper

The printer can feed paper from either of two sources: the MP tray or the optional 500-Sheet Lower Paper Cassette Unit.

Please note the following points:

- ❑ Paper should be of high quality and be relatively smooth, with a weight between 60 and 90 g/m² (16 to 24 lb).
- ❑ The printer is extremely sensitive to moisture. Be sure to store paper in a dry environment.
- ❑ Use of colored paper is acceptable, but coated paper should be avoided.
- ❑ You may use paper with preprinted letterheads, provided that the paper and ink are both of laser-printer type.

MP tray

You can load up to 150 sheets of plain paper into the MP tray. To load paper, follow these steps:

1. Lift off the tray cover.

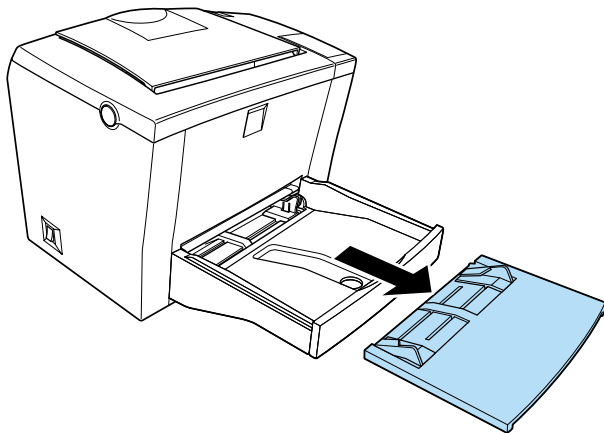

2. Fan a stack of paper and tap it on a flat surface to even the edges. Insert the paper printable side up into the tray and adjust the paper guides.

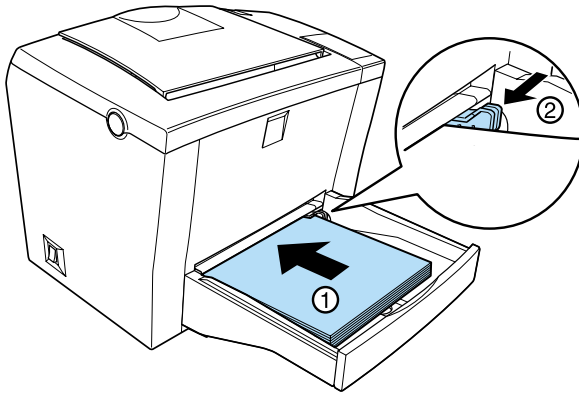

Note:

- ❑ *To widen the paper guides, press on the lever of the right paper guide while sliding it outwards.*
- ❑ *Load letterheads printable side up and with the letterhead portion toward the printer.*

3. Place the cover back on the MP tray as the protection against the dust and for manual-feed printing, as shown below.

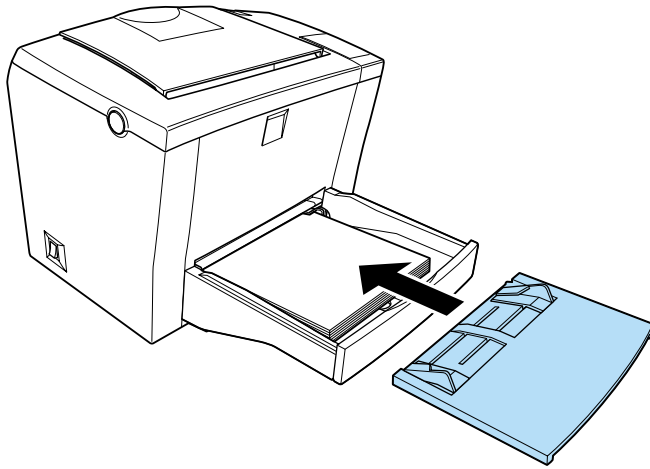

4. Raise the face-down tray and lift up the paper support on the top to prevent paper from falling off the edge.

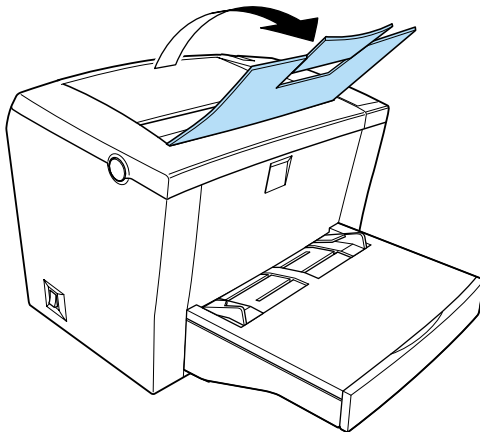

If you installed the optional Face-up Tray and you want the sheets to come out face-up, then raise the Face-up Tray instead, and set the paper path selector down.

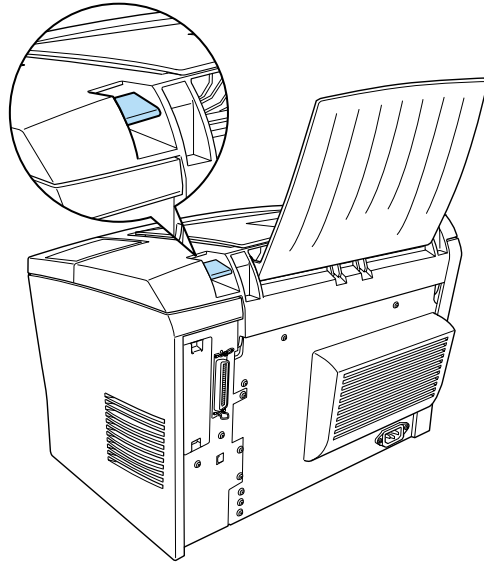

Note:

- ❑ *Before printing, make sure that the Paper Size setting in your printer driver matches the paper you load.*
- ❑ *If you want to print on paper heavier than 90g/m² (24 lb) or on special paper (such as envelopes, labels, transparencies, or thick paper), see “Printing on Special Media” on page 28.*

Manually loading paper

Follow these steps to load a single sheet of paper from the manual feed slot:

1. Make sure the cover is in place on the MP tray.
2. Insert a single sheet, with the printable side up, as far as it will go into the manual feed slot above the tray cover. Adjust the paper guides to match the paper size you are using.

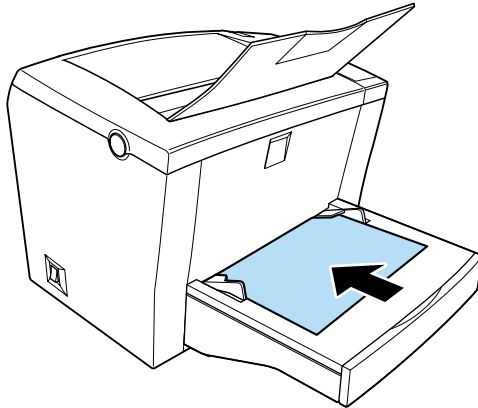

Note:

Load letterheads printable side up and with the letterhead portion toward the printer.

3. Make sure to change the Paper Source setting to MP Tray in the printer driver's Basic Settings menu.
4. Send the print data from the computer. The printer loads the paper from the manual feed slot.

500-Sheet Lower Paper Cassette Unit

Follow the steps below to load paper into the 500-Sheet Lower Paper Cassette Unit.

1. Pull the paper-tray out from the cassette unit.
2. Press down the plate in the paper-tray until it locks into position.

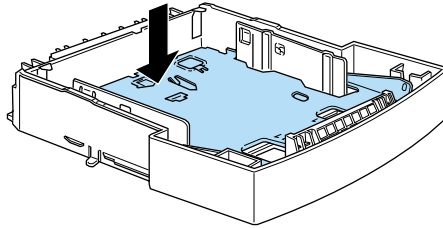

3. Fan a stack of paper and tap it on a flat surface to even the edges. Insert the paper printable-side up into the tray.

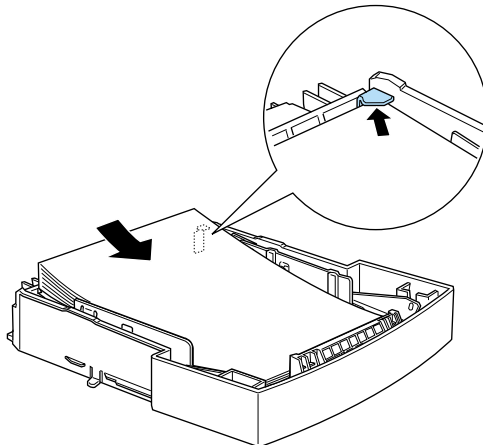

Note:

Load letterheads printable side up and with the letterhead portion toward the printer.

4. Insert the loaded paper-tray back into the unit.

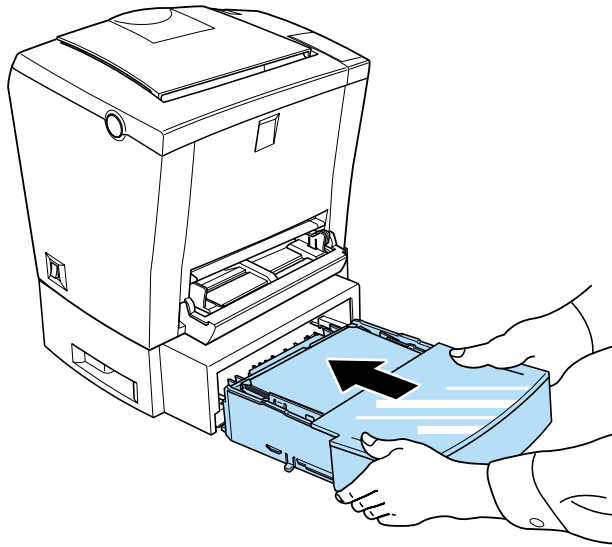

Printing on Special Media

Note:

Since the quality of any particular brand or type of paper may be changed by the manufacturer at any time, EPSON cannot guarantee the quality of any type of paper. Always test samples of paper stock before purchasing large quantities or printing large jobs.

The EPL-5800L Laser Printer can print on special paper stock such as envelopes, labels, transparencies, and thick paper.

Envelopes

You can load five to ten envelopes into the MP tray, depending on the envelope thickness (60 to 90 g/m²). Load envelopes with the flap side down and short edge first.

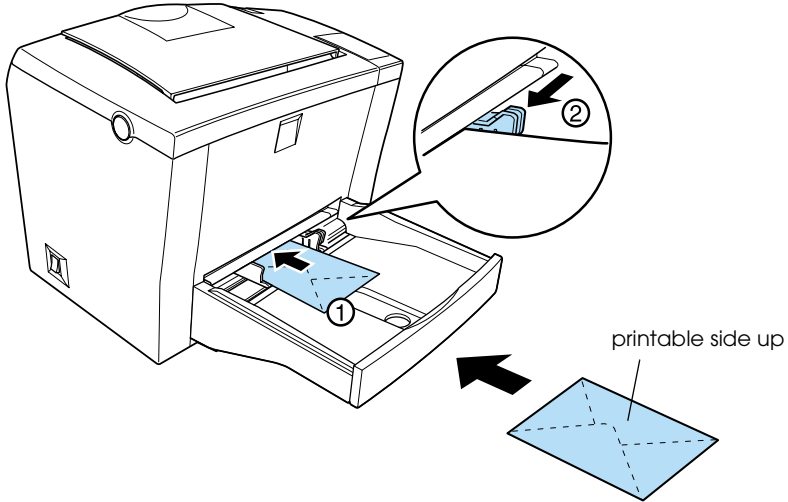

To print on envelopes, choose Thick Narrow in the printer driver's Paper setting found in the Extended Settings dialog box. This dialog box is accessed through the printer driver's Optional Settings tab.

The printing quality on envelopes may be irregular because different parts of an envelope have different thicknesses. Print one or two envelopes to check the print quality. If the printing is too light, adjust the print density as described in "Using the Printer Driver with Windows" on page 33.

Do not use window envelopes unless they are specially designed for laser printers. The plastic on most window envelopes will melt when it comes into contact with the hot fuser.

Labels

You can load five to ten sheets of labels into the MP tray. However, you may need to feed some types of labels one sheet at a time.

Use only labels designed for laser printers or plain-paper copiers.

To prevent the adhesive from coming into contact with printer parts, always use labels that completely cover the backing sheet, with no gaps between the individual labels.

You should test the label sheet for leaking adhesive by pressing a sheet of paper on top of a sheet of labels. If the paper sticks, do not use the labels.

Transparencies

You can load up to five transparencies into the MP tray. However, you may need to feed some types of transparencies one sheet at a time.

You can only use overhead projector transparencies and adhesive drafting film made for use with laser printers or plain-paper copiers.

When printing on transparencies, make sure to change the Paper setting to Transparency in the Extended Settings on the printer driver's Optional Settings menu.

Thick paper

You can load five to ten sheets of thick paper into the MP tray. However, you may need to feed some types of thick paper one sheet at a time. Use the thick paper of a weight between 90 and 163 g/m² (24 to 43 lb).

When printing on thick paper, be sure to change the Paper setting on the Extended Settings on the printer driver's Optional Settings menu. Choose Thick Narrow for thick paper which is less than 188 mm wide. Choose Thick Wide when printing on thick paper which is 188 mm or wider.

Chapter 3

Using the Printer Driver

Using the Printer Driver with Windows	33
Accessing the printer driver	33
EPSON Status Monitor 3 Utility	34
Increasing the Printing Speed	43
Note for using shared printers in Windows 2000 and NT 4.0	44
Choosing the printer port	49
Using Printer Driver with Macintosh	55
Accessing the printer driver	55
EPSON Status Monitor 3 Utility	55

Using the Printer Driver with Windows

To control your printer and change its settings, use the printer driver. The printer driver allows you to easily make all the print settings, including paper source, paper size, and orientation. To access the driver menus, see below.

Accessing the printer driver

You can access your printer driver directly from most Windows-based applications, or from your Windows operating system, as explained below. The printer driver settings made from many Windows applications override settings made when the driver is accessed from the operating system, so in most cases you should access the driver from your application to make sure you get the results you want.

- ❑ To access the printer driver from your application software, click the Print or Page Setup command on the File menu. You also may need to click Setup, Options, Properties, or a combination of these buttons.
- ❑ To access the printer driver from Windows Me, 98, 95, 2000 or NT 4.0, click Start, point to Settings, and click Printers. Next, right-click the EPSON EPL-5800L Advanced icon and click Properties (in Windows Me/98/95/2000) or Printing Preferences (in Windows 2000) or Document Defaults (in Windows NT 4.0).

Accessing Online Help

You can access Online Help from the printer driver. Online Help provides you with detailed information and instructions on the printer driver that controls your printer. It is automatically installed when you install the printer driver.

EPSON Status Monitor 3 Utility

About the EPSON Status Monitor 3 utility

EPSON Status Monitor 3 is a utility program that monitors your printer and gives you information about its current status. For example, you can find out the amount of remaining toner or the remaining functional life of the photoconductor unit through this utility. If a print error occurs, the utility provides you with a message describing the error. The Status Monitor 3 utility is accessed from within the printer driver. See “Accessing EPSON Status Monitor 3” on page 36 for more information.

Before using Status Monitor 3, be sure to read the printer driver’s README file. This file contains the latest information on the printer driver and Status Monitor 3.

Environment for the EPSON Status Monitor 3

Protocols

The protocols that must be installed to run EPSON Status Monitor 3 vary depending on your operating system and printer type. The following table divides printers into two categories: local printers and Windows shared printers.

Use this table to determine what protocols you need to install according to your operating system and printer type, then see the corresponding section for your operating system.

	Local Printer	Windows Shared Printers
Windows Me/98/2000	LPT/USB	LPT/USB
Windows 95	LPT	LPT
Windows NT 4.0	LPT	LPT
Macintosh	USB	--

Local Printer

Connect the printer directly to the printer port of your computer.

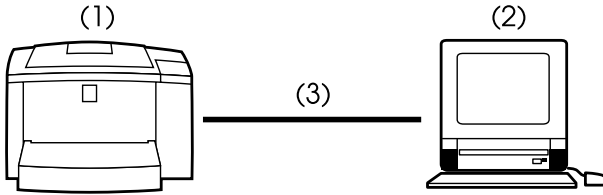

- (1) local printer
- (2) Windows Me/98/95/2000/NT 4.0/Macintosh
- (3) Parallel cable/USB cable

Windows shared printer

To monitor a shared printer from the client through the server machine, you have to make a setting change on the printer driver installed on the server machine. The change involves selecting the Allow monitoring of shared printers check box in the Monitoring Preferences dialog box. You can access the Monitoring Preferences dialog box through the Utility tab of the printer driver's Properties dialog box.

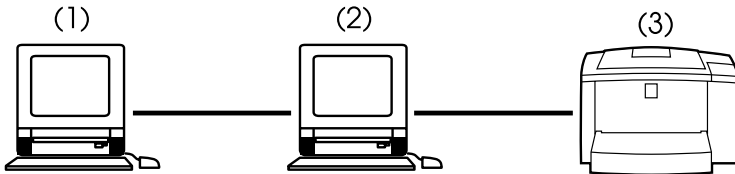

- (1) client machine
- (2) server machine
- (3) Windows shared printer

See the README file for more information about support for Windows shared printers.

Windows Me/98/95/2000	Windows NT 4.0
Bi-directional support is necessary.	No special settings needed.

For Windows Me/98/95/2000:

You need to enable bi-directional support in the printer's Properties dialog box. For Windows Me/98/95 users, click the Details tab and then click Spool Settings. For Windows 2000 users, click the Ports tab. Make sure the Enable bi-directional support for this printer check box is selected.

Accessing EPSON Status Monitor 3

EPSON Status Monitor 3 monitors the printer during printing and while the EPSON Status Monitor 3 dialog box is open.

Follow these steps to access EPSON Status Monitor 3:

1. Double-click the My Computer icon.
2. Double-click the Printers folder.
3. Right-click the icon for your printer, and click Properties.

4. Click the Utility tab.

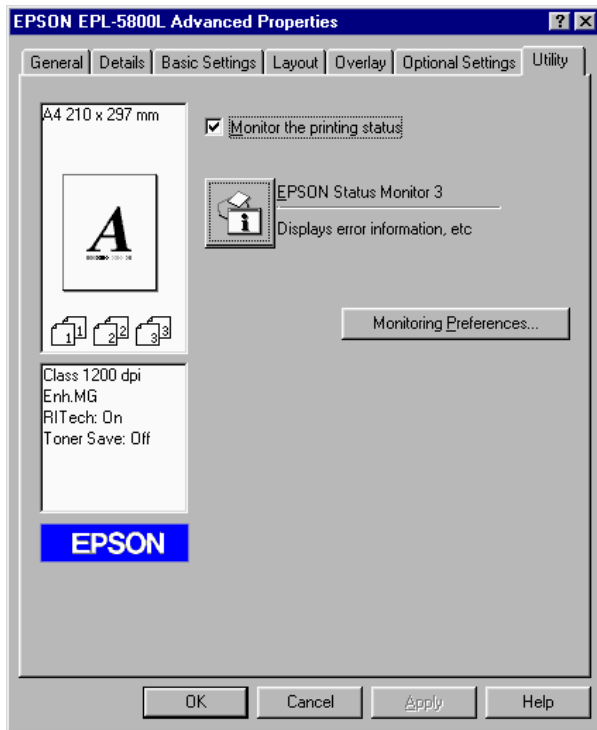

5. Click the EPSON Status Monitor 3 icon to start the EPSON Status Monitor 3 utility.

Note:

Clearing the Monitor the printing status check box during normal operation causes the Status Alert window to stop monitoring some errors. See "Status Alert Window" on page 41 for more information on this function.

Getting Printer Status Details

You can monitor printer status and obtain information on consumable products using the EPSON Status Monitor 3 dialog box.

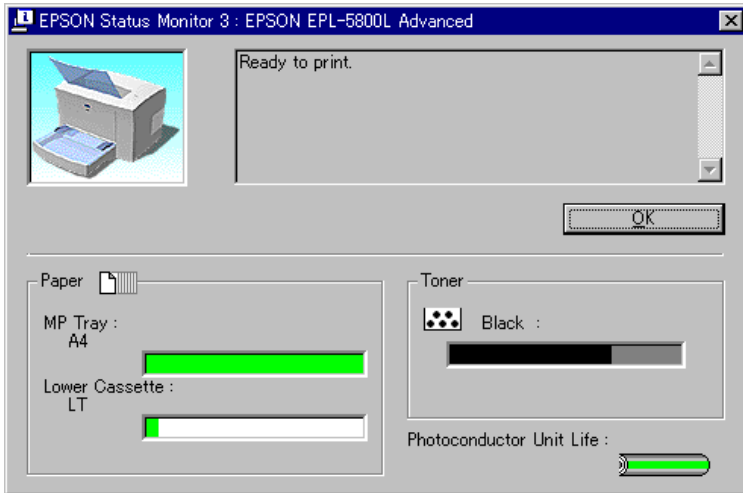

Printer image:

The image at the upper left shows the printer status graphically.

Text box:

The text box next to the printer image displays the current status of the printer. If a problem occurs, the most probable solution is displayed.

OK button:

Clicking this button closes the dialog box.

Paper:	Displays the paper size and the approximate amount of paper remaining in the paper source. Information for the optional 500-Sheet Lower Paper Cassette Unit is displayed only if this option is installed.
Toner:	Indicates the amount of remaining toner. The toner icon flashes if toner is low (10 percent or less).
Photoconductor Unit Life:	Indicates the remaining functional life of the photoconductor unit.

Setting Monitoring Preferences

To make specific monitoring settings, click the Monitoring Preferences button in the Utility tab of the printer driver's Properties dialog box. The Monitoring Preferences dialog box appears.

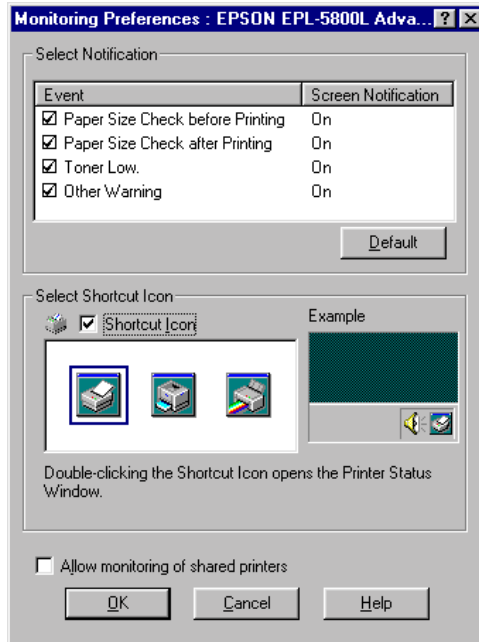

The following settings and buttons appear in the dialog box:

Select Notification: Use the check boxes to select the types of error that you wish to be notified about.

Default button: Restores default settings.

Select Shortcut Icon:	To use the shortcut icon, select the Shortcut Icon check box and choose an icon. The icon you select appears on the right side of the task bar. Once the shortcut icon is in the task bar, you can double-click it to open the Status Monitor 3 dialog box. You can also right-click the shortcut icon and select Monitoring Preferences to open the Monitoring Preferences dialog box, and EPSON EPL-5800L Advanced to open the EPSON Status Monitor 3 dialog box.
Allow monitoring of shared printers check box:	To monitor a shared printer, check this box. You need to make this setting on the server machine.
OK button:	Saves new changes.
Cancel button:	Cancels any changes.
Help button:	Opens the Help screen for the Monitoring Preferences dialog box.

Status Alert Window

This window indicates what type of error has occurred and offers you a possible solution. It closes automatically once the problem is cleared.

The Status Alert window opens under the conditions you select in the Monitoring Preferences dialog box.

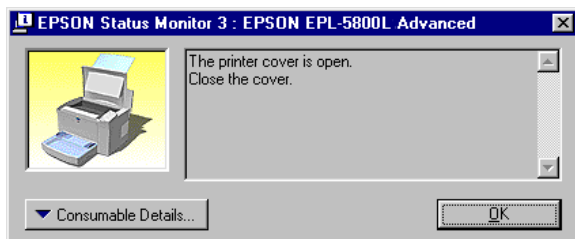

If you wish to see information about printer consumables, click the Consumable Details button. If you click this button, the dialog box will not disappear even after the problem is cleared. To close the box you need to click the OK button.

Stopping Monitoring

The EPSON Status Monitor 3 utility monitors the printer during printing and while the EPSON Status Monitor 3 dialog box is open.

To monitor during printing only, close the EPSON Status Monitor 3 dialog box.

To stop monitoring completely, clear the Monitor the printing status check box in the Utility tab of the printer driver's Properties dialog box. You may want to do this to speed up printing or if you don't need to monitor the printer.

If you clear the Monitor the printing status check box, the Status Alert window no longer comes up to notify you when an error occurs. However, you can still find out the current printer status by clicking the EPSON Status Monitor 3 icon in the Utility tab of the printer driver's Properties dialog box.

Note:

In Windows NT 4.0, the Monitor the printing status check box is displayed in the Utility tab of Document Defaults.

Increasing the Printing Speed

Faster printing with Direct Memory Access (DMA) is possible if your printer is connected to your computer through an Extended Capability Port (ECP), a type of parallel port with expanded specifications. With DMA and ECP, you can send print-job data directly to the printer without going through the CPU, which increases the effectiveness of data flow.

Before using DMA to transmit a print job confirm the following points.

- ❑ Check if your computer supports DMA. To confirm if your computer has an ECP chip installed, contact the manufacturer or look in the computer's documentation.
- ❑ Confirm the parallel port setting is "ECP" or "ENHANCED" through the BIOS Setup. Refer to your computer's documentation to set the BIOS. However, before setting the BIOS, uninstall the EPL-5800L printer driver. After setting the BIOS, re-install the printer driver.

Confirming availability of DMA

Using DMA increases your printing speed. You can confirm if your computer can use DMA by checking the Driver Settings dialog box on the Optional Settings menu of the Properties of your Printer driver.

Note for using shared printers in Windows 2000 and NT 4.0

If you are using a shared printer in Windows 2000 or NT 4.0, it is important that you follow the instructions below carefully, especially “Accessing the printer through a network,” which describes how to install the printer driver on Windows 2000 and NT 4.0 clients. If you do not follow these instructions, you may not be able to properly install or use the printer driver.

First, you need to set up the printer as a shared printer on the computer to which the printer is connected. Then, you must specify the network path to the printer from each computer that will use it, and install the printer software on those computers.

Setting up your printer as a shared printer

Follow these steps to share a printer that is connected directly to your computer with others on a network.

1. Click Start, point to Settings, and click Printers.
2. Select your printer, then click Sharing on the File menu.

3. Click Shared (for Windows 2000 users, select Shared as), then type the Shared Name.

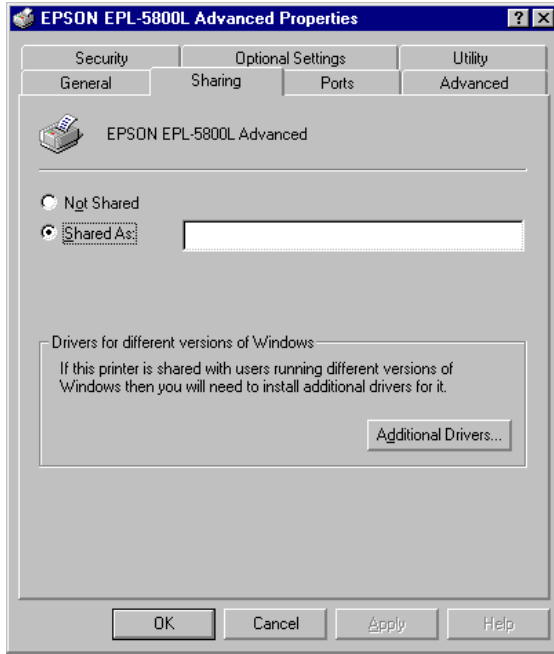

4. Click OK.

Note:

For Windows NT 4.0 users, do not select a driver from the Alternate Drivers list. For Windows 2000 users, do not select the driver from the Additional Drivers list in the Additional Drivers dialog box.

Accessing the printer through a network

To access your printer from another computer on the network, follow these steps.

Note:

Your printer must be set up as a shared resource on the computer to which it is directly connected before you can access it from another computer.

1. Install the printer driver to the client computer from the software CD-ROM.
2. Open the Printer folder from the Control Panel, then open the Properties for your printer.
3. Click the Ports tab, then click Add Port.

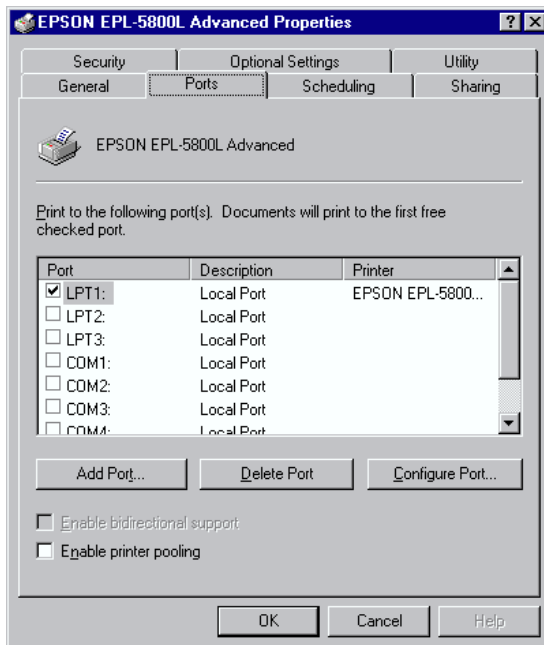

4. The following dialog box appears. Select Local Port, then click New Port.

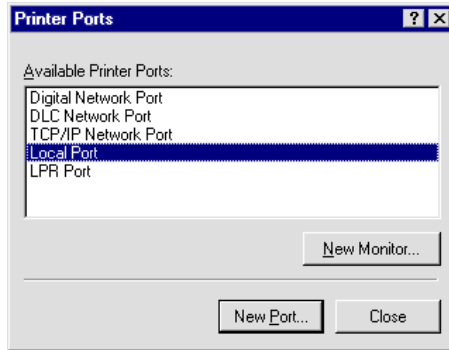

5. The following dialog box appears. In the text box, type the following information:

\\name of computer that is connected to the printer\nname of the shared printer

Then click OK.

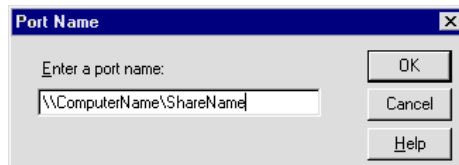

6. In the Printer Ports dialog box, click Close to return to the Ports menu.

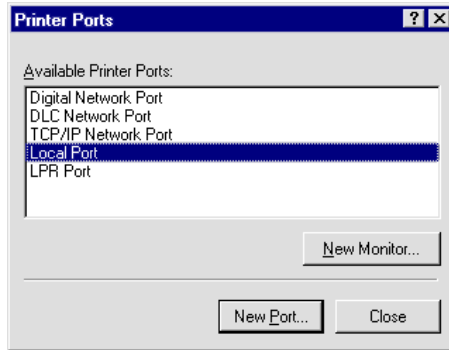

7. On the Ports menu, make sure that the new port is added and the check box is selected. Click OK to close the printer driver.

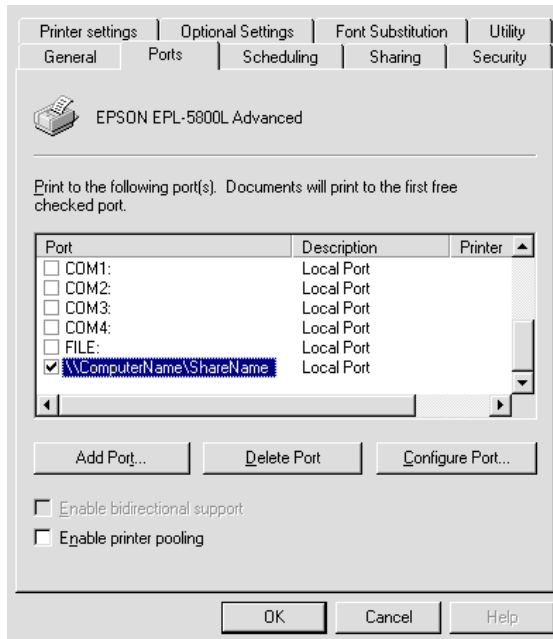

Choosing the printer port

You have to specify the interface you are using to print. The standard interfaces that come with your printer are parallel and USB. To specify the interface, you need to choose the appropriate printer port setting in the printer driver.

Parallel connection

The Windows platform supports the parallel interface. The instructions given below are for Windows 98, but the procedure is similar on other Windows operating systems.

1. Click the Start button, point to Settings, and then click Printers.
2. Right-click the EPSON EPL-5800L Advanced icon, and click Properties in the menu that appears.
3. Select the Details tab.

4. Click the arrow next to the Print to the following port drop-down list, then select LPT1: (ECP Printer Port).

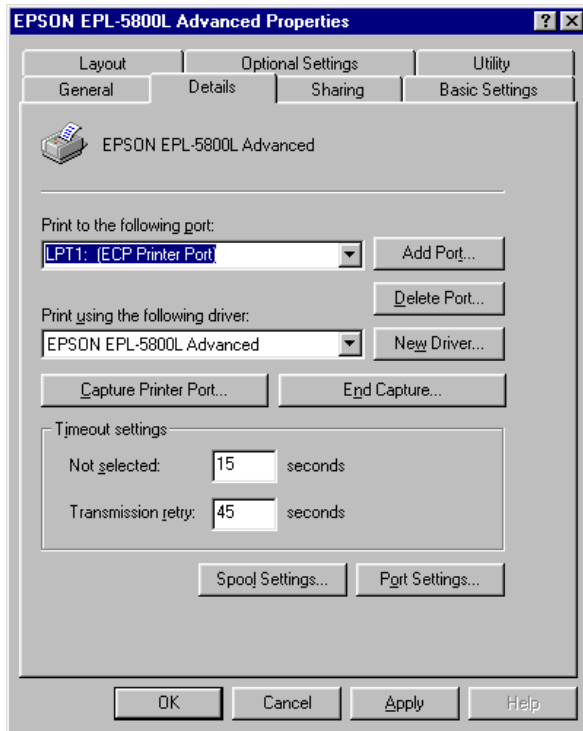

5. Click OK to save this setting.

Using the ECP mode

To use the ECP mode with a parallel (IEEE 1284-B compliant) connection, your computer must support ECP mode.

To use the ECP mode, follow these steps:

1. Make the ECP mode settings in the BIOS setting program that comes with your computer. (For details of the settings and the program, see your computer manual.)
2. Click the Start button, point to Settings, and then click Control Panel.
3. Right-click the System icon, and click Open in the menu that appears.
4. Select the Device Manager tab.
5. Select ECP Printer Port under Ports [COM & LPT], then click the Properties button.
6. Select the Resources tab.
7. Make the appropriate setting in the Resource settings dialog box. (This setting depends on your computer system. For details, see your computer manual.)
8. Click OK to save the settings.

USB connection

The USB interface that comes with your printer complies with Microsoft Plug and Play (PnP) USB specifications.

Note:

Only Macintosh[®] and PC systems equipped with a USB connector and running Mac[®] OS 8.1 (or later) or Windows Me/98/2000 respectively support the USB interface.

For Windows Me/98/2000

1. Click the Start button, point to Settings, and then click Printers.
2. Right-click the EPSON EPL-5800L Advanced icon, and click Properties in the menu that appears.
3. Select the Details tab.

4. Click the arrow next to the Print to the following port drop-down list. In Windows Me or 98, select EPUSB1: (EPSON EPL-5800L). In Windows 2000, check USB001 in the list on the Ports menu.

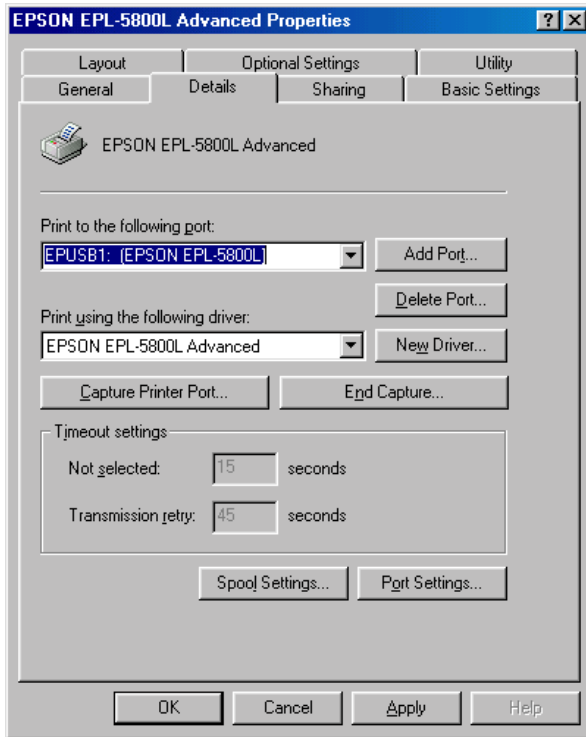

5. Click OK to save this setting.

For Macintosh

Note:

- ❑ *The USB interface is not compatible with the Macintosh operating system's QuickDraw GX.*
 - ❑ *If you are connecting the USB cable to your Macintosh through a USB hub, be sure to connect using the first hub in the chain. The USB interface may be unstable depending on the hub used. If you experience problems with this type of setup, connect the USB cable directly to your computer's USB connector.*
1. Select Chooser from the Apple menu. Click your printer's icon and then click the USB port your printer is connected to.

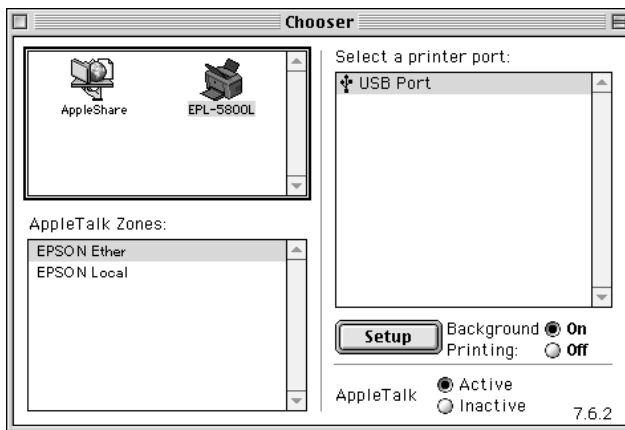

2. Click the Background Printing radio buttons to turn background printing on or off.

Note:

- ❑ *Background printing must be turned on for the EPSON Status Monitor 3 to manage print jobs.*
 - ❑ *When background printing is on, you can use your Macintosh while it is preparing a document for printing.*
3. Close the Chooser.

Using Printer Driver with Macintosh

Accessing the printer driver

To control your printer and change its settings, use the printer driver. The printer driver allows you to easily make all the print settings, including paper source, paper size, and orientation. To access the driver menus, see below.

To access the printer driver from Macintosh, Choose Chooser from the Apple menu. Then click the EPL-5800L icon and click Setup.

Accessing Online Help

You can access the Online Help from the printer driver. The Online Help provides you with detailed information and instructions on the printer driver that controls your printer. It is automatically installed when you install the printer driver.

EPSON Status Monitor 3 Utility

About the EPSON Status Monitor 3 utility

EPSON Status Monitor 3 is a utility program that monitors your printer and gives you information about its current status. For example, you can find out the amount of remaining toner or the remaining functional life of the photoconductor unit through this utility. If a print error occurs, the utility provides you with a message describing the error. The Status Monitor 3 utility is accessed from within the printer driver. See “Accessing EPSON Status Monitor 3” on page 56 for more information.

Before using Status Monitor 3, be sure to read the printer driver’s README file. This file contains the latest information on the printer driver and Status Monitor 3.

Accessing EPSON Status Monitor 3

EPSON Status Monitor 3 monitors the printer during printing and while the EPSON Status Monitor 3 dialog box is open.

You can access the EPSON Status Monitor 3 utility by selecting the EPSON Status Monitor 3 alias in the Apple menu.

Note:

- ❑ *The appropriate printer port must already be selected in the Chooser so that necessary information can be received from the selected printer driver when the EPSON Status Monitor 3 starts. If the printer port is not correct, an error will occur.*
- ❑ *If you change the printer driver in the Chooser while the spool file is printing in the background, output to the printer may be disrupted.*
- ❑ *Printer and consumable products status information appears in the status window only if the Chooser is acquiring status normally.*

Getting printer status details

You can monitor printer status and obtain information on consumable products using the EPSON Status Monitor 3 dialog box.

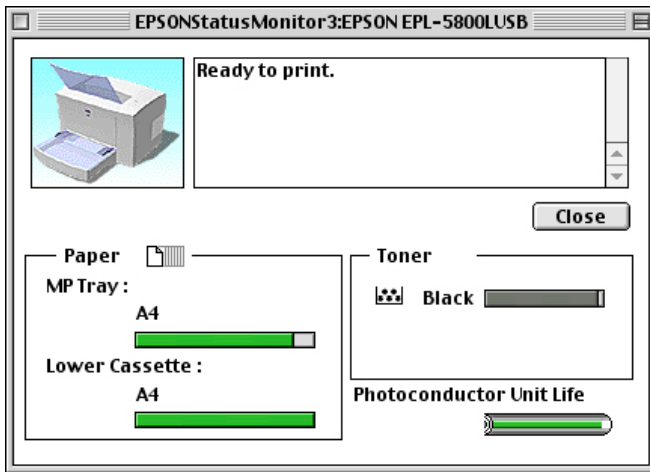

- Printer image: The image at the upper left shows the printer status graphically.
- Text box: The text box next to the printer image displays the current status of the printer. When a problem occurs, the most probable solution is displayed.
- Close button: Clicking this button closes the dialog box.
- Paper: Displays the paper size and the approximate amount of paper remaining in each paper source. Information for the optional 500-Sheet Lower Paper Cassette Unit is displayed only if this option is installed.

Toner:	Indicates the amount of remaining toner. The toner icon flashes if toner is low (10 percent or less).
Photoconductor Unit Life:	Indicates the remaining functional life of the photoconductor unit.

Monitor Setup

To make specific monitoring settings, click the Monitor Setup button when you start the status monitor. The Monitor Setup dialog box appears.

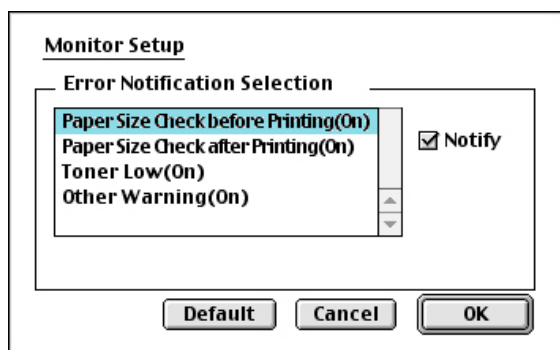

The following settings and the buttons appear in the dialog box.

Error Notification Selection Use the check boxes to select the types of error that you wish to be notified about.

Default button: Restores default settings.

Cancel button: Cancels any changes.

OK button: Saves new changes.

Status Alert window

This window indicates what type of error has occurred and offers you a possible solution. It closes automatically once the problem is cleared.

If you wish to see information about printer consumables, click the Show details button. If you click this button, the dialog box will not disappear even after the problem is cleared. To close the box you need to click the OK button.

Note:

The Status Alert window automatically appears when a problem occurs with your printer.

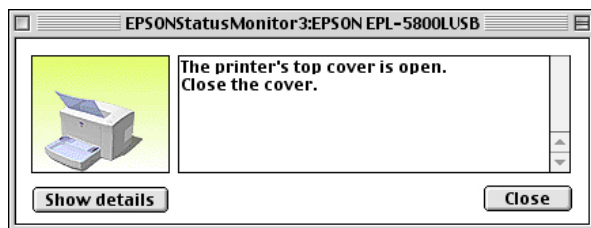

Chapter 4

Installing and Removing Options

Printer Options.....	.61
500-Sheet Lower Paper Cassette Unit.....	.62
Installing.....	.62
Removing.....	.63
Face-up Tray.....	.64
Installing.....	.65
Using.....	.66
Removing.....	.66
Memory Module.....	.67
Installing.....	.67
Removing.....	.72

Printer Options

You can add to your printer's capabilities by installing any of the following options:

- ❑ 500-Sheet Lower Paper Cassette Unit (C81336*) increases paper feeding capacity.
- ❑ Face-up Tray (C813372) enables face-up output.
- ❑ Optional memory module expands your printer's memory.

Note:

The asterisk () is a substitute for the last digit of the product number, which varies by country.*

Each of these options is discussed in its own section.

If you purchased your printer and the options at the same time, first set up the printer and run the print test by following the instructions in the *Setup Guide*. Then install the options.



Caution:

Before installing an option, carefully read the documentation that comes with the option.

500-Sheet Lower Paper Cassette Unit

The optional 500-Sheet Lower Paper Cassette Unit gives you a second paper source in addition to the MP tray. This section describes how to install the cassette unit.

Installing

Follow the instructions below to install the 500-Sheet Lower Paper Cassette Unit:

1. Turn off the printer.
2. Unplug the printer's power cord from the electrical outlet and from the printer.
3. Remove all interface cables from the interface connectors.
4. Make sure that the printer and the cassette unit are facing the same way. Lift the printer and align the pins on the cassette unit with the holes on the bottom of the printer, then lower the printer until it rests securely on the cassette unit.

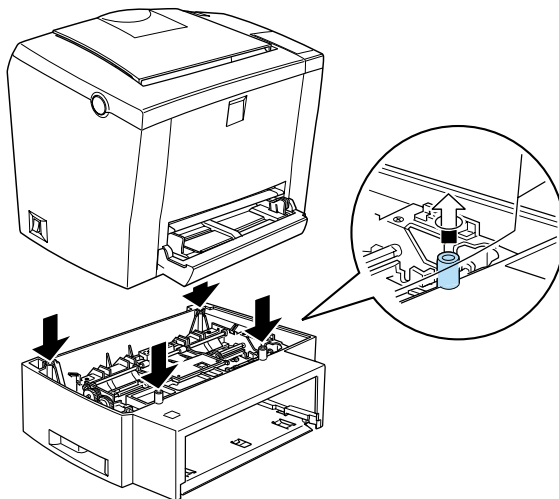

5. Reconnect any interface cables you removed.
6. Make sure that the printer's power switch is turned off before plugging the power cord into the printer and into an electrical outlet.
7. Turn on the printer.

To confirm that the 500-Sheet Lower Paper Cassette Unit is installed correctly, print a status sheet. See "Testing the Printer Connection" in the *Setup Guide*. Confirm that the 500-Sheet Lower Paper Cassette Unit is listed under the Paper Source section of the status sheet. If it is not listed on the status sheet, try reinstalling it.

To use the 500-Sheet Lower Paper Cassette Unit as the paper source, be sure to choose Lower Cassette in the printer driver as the Paper Source setting.

If your computer is running Windows Me, 98, 95, 2000 or NT 4.0, you can also confirm that the 500-Sheet Lower Paper Cassette Unit is correctly installed by checking the information displayed in the Optional Settings tab of the printer driver.

Removing

Follow the instructions below to remove the 500-Sheet Lower Paper Cassette Unit:

1. Turn off the printer.
2. Unplug the printer's power cord from the electrical outlet.
3. Remove all interface cards from the interface connectors.
4. Carefully lift the printer off the 500-Sheet Lower Paper Cassette Unit and place it on a flat, stable surface.

5. Repack the optional 500-Sheet Lower Paper Cassette Unit in its original carton.
6. Reconnect all the interface cables.
7. Plug the printer's power cord into an electrical outlet.
8. Turn on the printer.

Face-up Tray

The printer normally outputs paper face-down on top of the printer. If you want face-up output, you can install the optional Face-up Tray (C813372). This tray gives you immediate viewing of your printed output and is recommended for printing on media that requires a straight-through paper path, such as labels and transparencies.

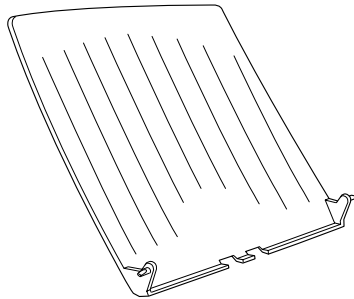

Installing

Follow the instructions below to attach the Face-up Tray to the printer:

1. Turn off the printer.
2. Attach the Face-up Tray by sliding the mounting pins into the corresponding holes, one at a time. Do not force both sides in at once.

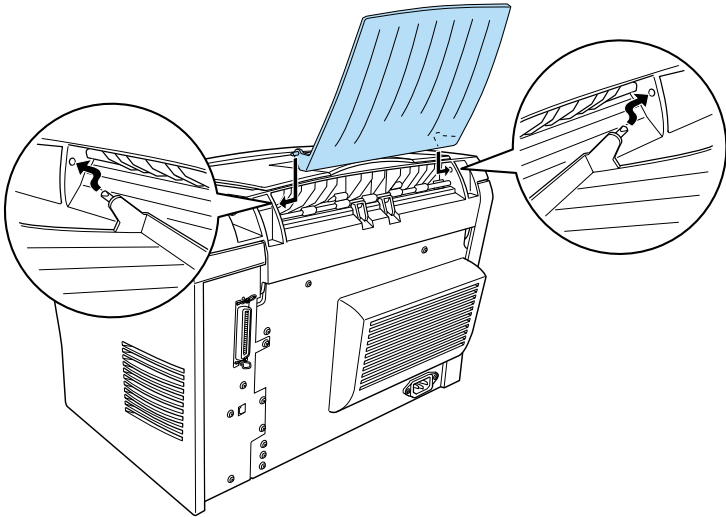

Using

The printer is factory set for face-down output. After installing the Face-up tray, you can switch the paper path from face-down to face-up by pushing the paper path selector down. The paper path selector is located on the right side of the printer, near the back.

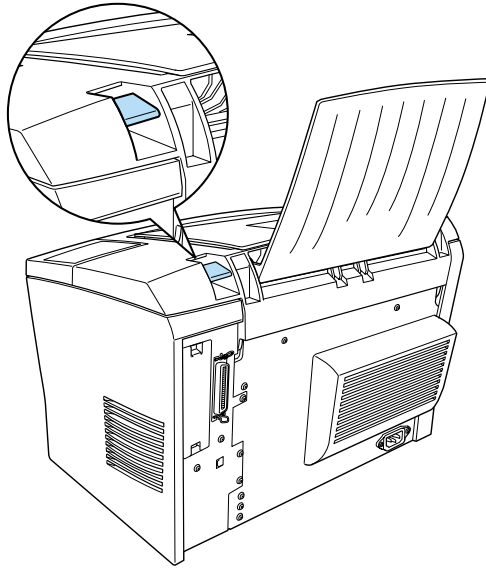

Removing

1. Turn off the printer.
2. Remove the Face-up tray.
3. Switch the paper path selector up.

Memory Module

By installing a Single In-line Memory Module (SIMM), you can increase printer memory up to 13 MB (printer standard 2 MB plus optional 8, 16, or 32 MB). You may want to add additional memory if you are having difficulty printing complex graphics.

Note:

The maximum expandable memory is 13 MB. Even with 16 or 32 MB installed, only 13 MB are accessible.

You can purchase SIMMs from various vendors. Be sure that the SIMM you purchase meets the following requirements:

- 72pin, EDO type
- 8, 16, or 32 MB
- Access speed of 60 ns or less
- Dimensions within 108 mm (4.25 inches) × 26 mm (1.02 inches), with a thickness of 10 mm (0.4 inch)

Installing

Follow the instructions below to install a SIMM in the printer:



Warning:

To avoid electrical shock, do not attempt to install a SIMM unless the printer is turned off.

1. Make sure that the printer is not plugged in.

2. Press the latch on the left side of the printer, and raise the printer cover.

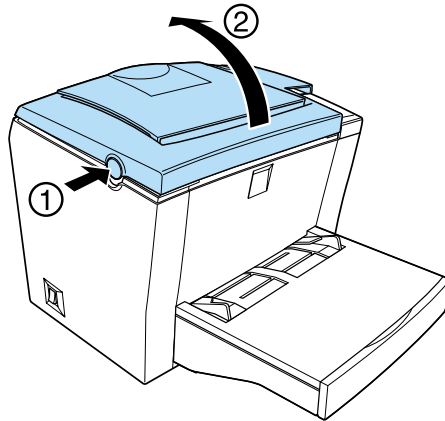

3. Face the right side of the printer, and using a cross-head screwdriver, remove the two screws holding the side cover in place. Remove the side cover by pulling it toward you.

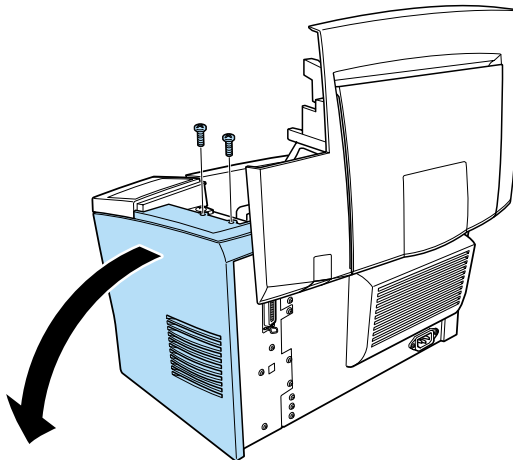

Note:

Be careful to avoid dropping screws into the printer when removing them. It may be helpful to use a magnetic screwdriver.

4. Identify the slot into which the SIMM is to be installed—the long slot with the two clips at the ends. Make sure that the clips are open (leaning away from the slot).

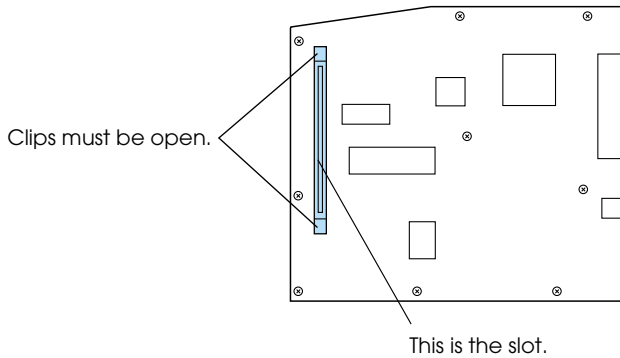

Warning:

Avoid touching the electrical components that are exposed after you remove the side cover. Be aware that these components may become hot while the printer is in use.



Caution:

Before you install the module, be sure to discharge any static electricity by touching a grounded piece of metal. Otherwise, you may damage static-sensitive components.

5. Firmly insert the SIMM into the slot at an angle from the right side, as shown below. Hold both sides of the SIMM and turn it to the perpendicular to lock it into place.

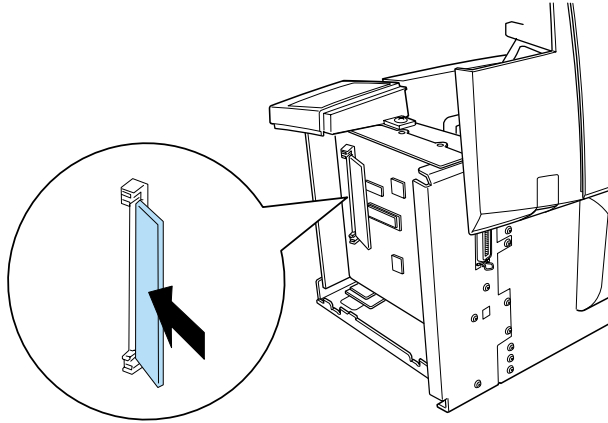

6. Set the side cover back into place.

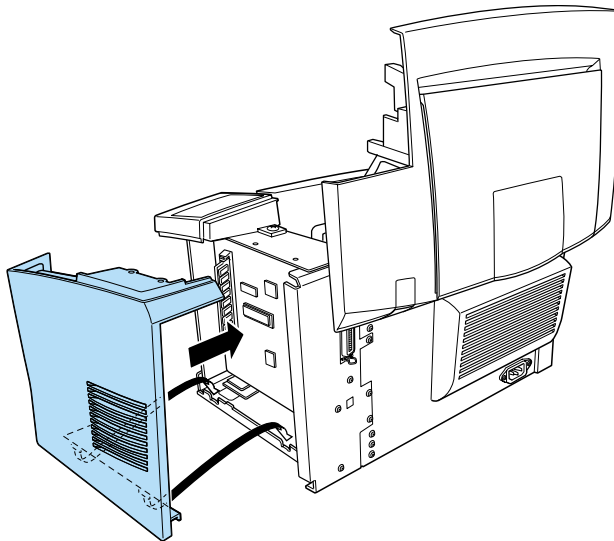

7. Fasten the side cover with the two screws.

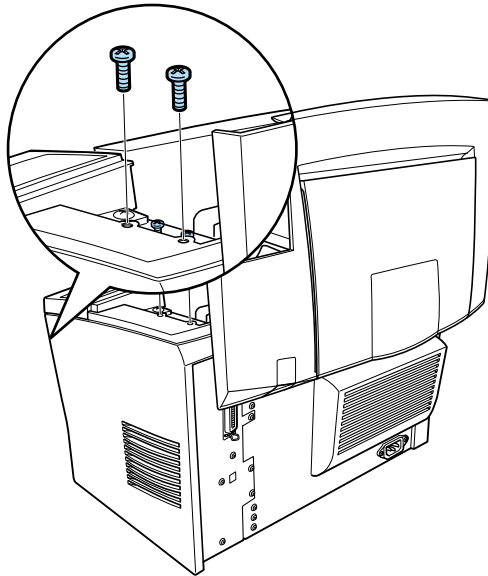

8. Gently close the printer cover.
9. Plug in the printer and turn it on.

Note:

After installing the printer driver, you can confirm the optional memory is installed correctly. Windows users can check in the Printer Driver by selecting the Optional Settings tab under Properties.

To verify that memory is correctly installed, print a status sheet. See "Testing the Printer Connection" in the *Setup Guide*.

If an incorrect amount of memory is shown on the status sheet, turn off the printer and review the steps above to make sure you correctly installed the SIMM. If the amount of memory is still incorrect, contact your dealer or a qualified service representative for assistance.

If your computer is running Windows Me, 98, 95, 2000 or NT 4.0, you can also confirm that the memory module is correctly installed by checking the information displayed in the Optional Settings tab of the printer driver.

Removing

Follow the instructions below to remove the SIMM:

1. Make sure that the printer is not plugged in.
2. Press the latch on the left side of the printer, then raise the printer cover.

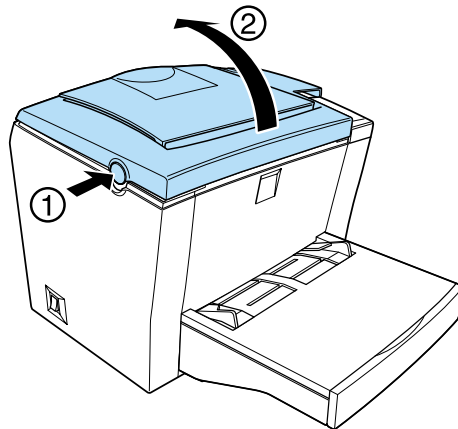

3. Face the right side of the printer, and using a crosshead screwdriver, remove the two screws holding the side cover in place. Remove the side cover by pulling it toward you.

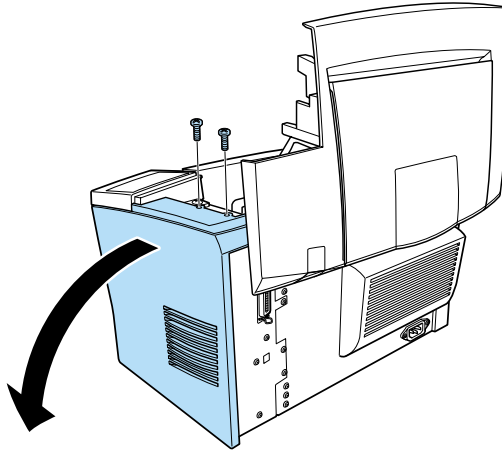

4. Push the clips on each side of the SIMM slot outward to release the memory module.

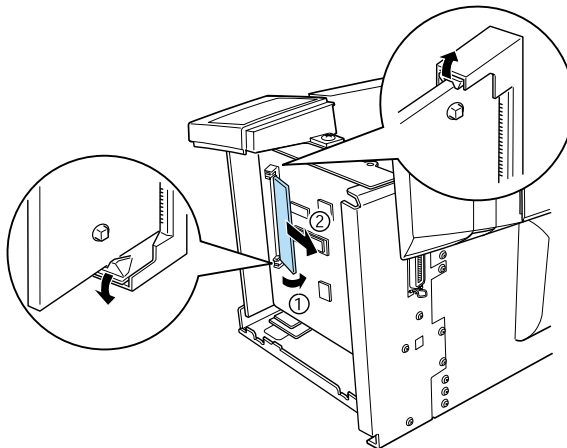

5. Grasp the SIMM firmly on both ends and pull it out.

6. Set the side cover back into place.

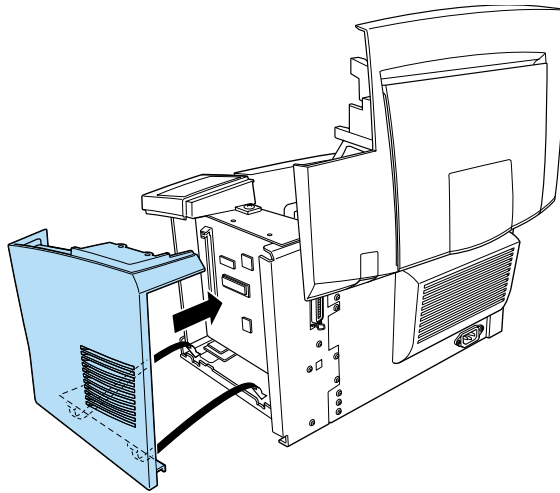

7. Fasten the side cover with the two screws.

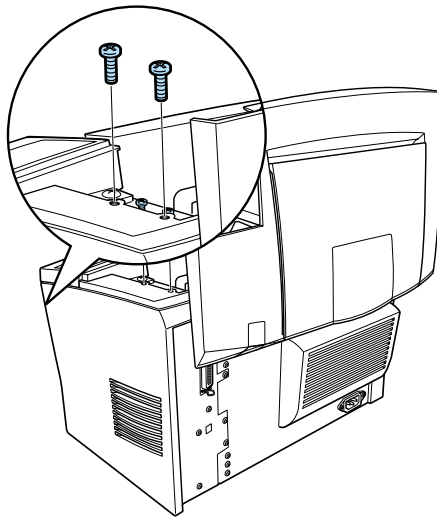

8. Gently close the printer cover.

Chapter 5

Replacing Consumables

Replacing the Developer Cartridge.....	77
Replacing the Photoconductor Unit	82

Your printer uses two consumable components, which are listed below along with their approximate service lives.

Developer cartridge (S050010)

Up to 6,000 pages at 5% print ratio on A4 or Letter size paper, depending on the complexity of print jobs.

Photoconductor unit (S051055)

Up to 20,000 pages at 5% print ratio.

You can view the condition of the consumables using the EPSON Status Monitor 3 utility.

Replace the developer cartridge if you notice a decline in print quality. Replace the photoconductor unit only if print quality problems remain after replacement of the developer cartridge.

Replacing the Developer Cartridge

Follow these steps to replace the developer cartridge:

1. Make sure the printer is turned off.
2. Make sure the output tray on top of the printer is lowered.
3. Open the printer cover by pressing the latch on the left side of the printer and lifting the cover up all the way.

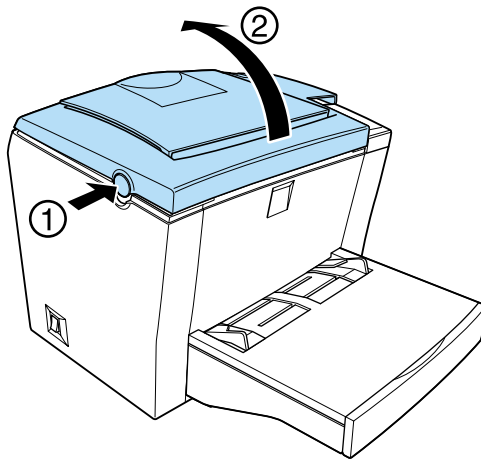

Caution:

You must completely open the printer cover when replacing the developer cartridge; otherwise, you may damage the printer.

4. Hold the cartridge by the handle and pull it straight up and out of the printer.

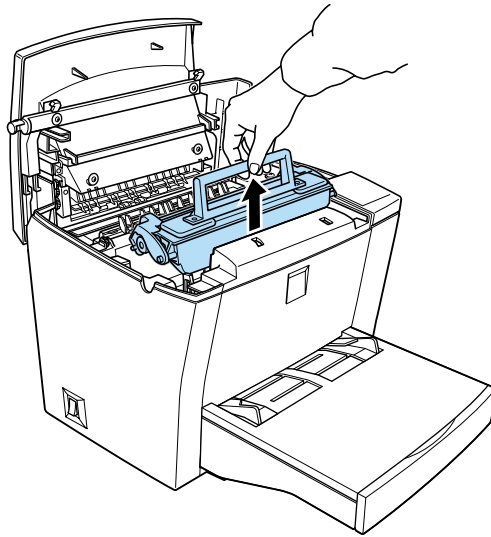

Warning:

Do not touch the fuser, which is marked CAUTION Hot Surface Avoid Contact. If the printer has been in use, the fuser may be very hot.



Caution:

Be careful not to spill any remaining toner from the used developer cartridge. If toner is spilled inside the printer, clean it with a clean, dry, lint-free cloth or with a vacuum-cleaning device.

5. Dispose of the used developer cartridge properly.

6. Remove the new developer cartridge from its bag. While holding the cartridge horizontally, gently shake it a few times from side to side and then from front to back to distribute the toner evenly.

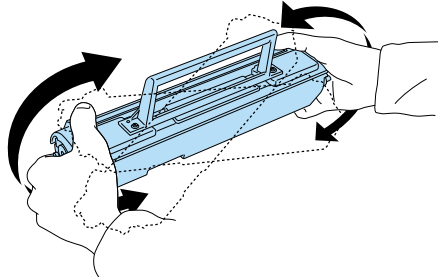

7. Remove the protective tape seal from the developer cartridge completely.

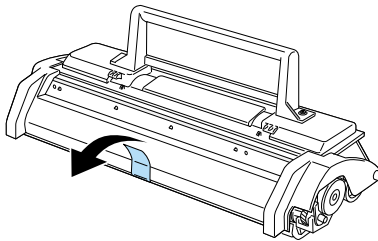

Caution:

Never touch the developing roller under the flap; otherwise, print quality may decline.

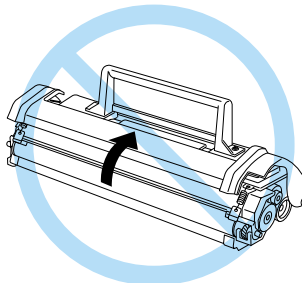

8. Hold the cartridge by its handle and lower it into the printer, making sure that the pins on both sides of the cartridge fit into the grooves inside the printer. Slide the cartridge gently into the opening until it locks into place.

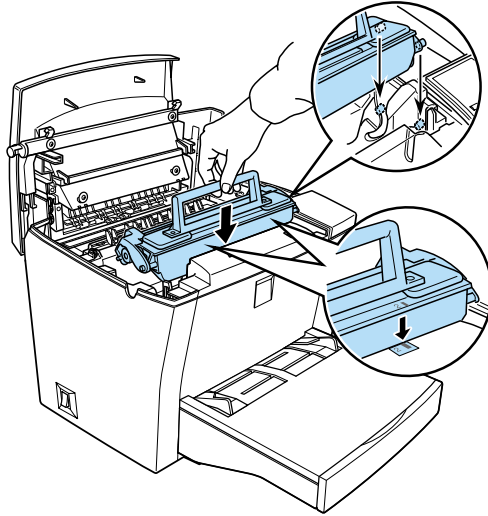

9. Lower the printer cover. Press it gently until it clicks shut.

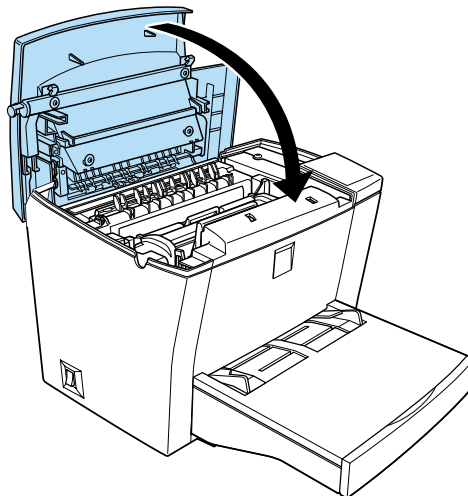

- When you turn on the printer, access the Printer Settings dialog box in the printer in the Optional Settings tab of the printer driver in Windows, or click the Setup button in the Chooser dialog box, and click the Printer Settings button in Macintosh. Click the Toner Level Clear button. The toner clear dialog box is displayed.

If the Status Monitor 3 window displays a warning message, click the Consumable Details button in Macintosh, then click the Toner Level Clear button in the dialog box that appears.

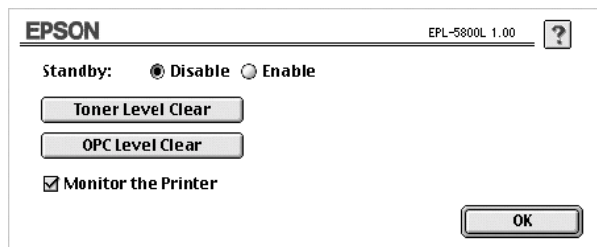
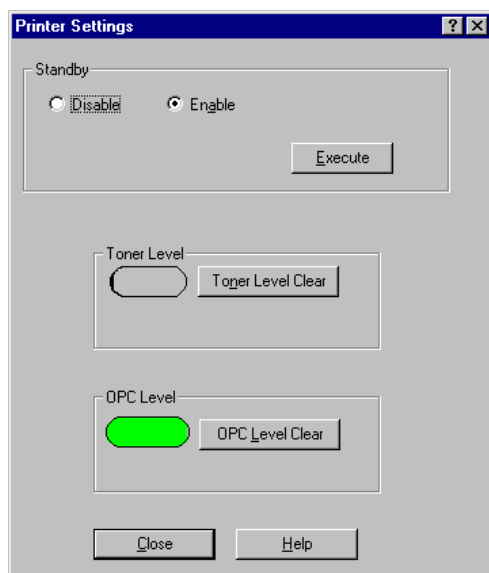

11. Click OK to reset the toner level counter.

Whenever you replace the developer cartridge, you should clean the paper roller as described in “Cleaning the Printer” on page 113.

Replacing the Photoconductor Unit

1. Make sure the printer is turned off.
2. Make sure the output tray at the top of the printer is lowered.
3. Open the printer cover by pressing the latch button on the left side of the printer and lifting the cover up all the way.

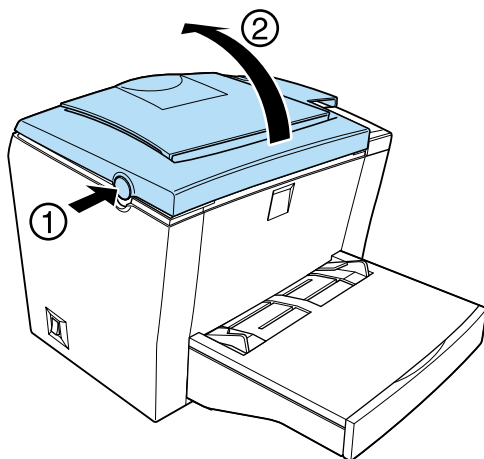

Caution:

You must completely open the printer cover to replace the photoconductor unit; otherwise, you may damage the printer.

4. Remove the developer cartridge.

5. Slide the photoconductor unit gently out of the printer, as shown below.

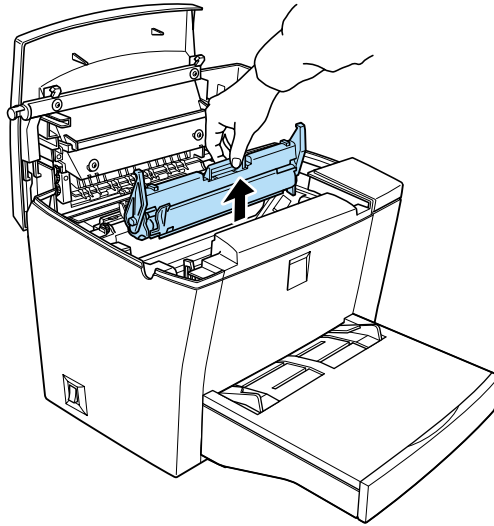

Warning:

Do not touch the fuser, which is marked CAUTION Hot Surface Avoid Contact. If the printer has been in use, the fuser may be very hot.

6. Properly dispose of the used photoconductor unit.
7. Remove the new photoconductor unit from its bag.



Caution:

Never touch the photoconductor unit's light-sensitive drum; otherwise, print quality may decline.

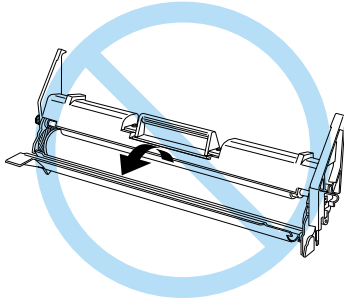

8. Insert the pins on both sides of the new photoconductor unit into the grooves inside the printer. Slide the unit gently into the opening until it locks into place.

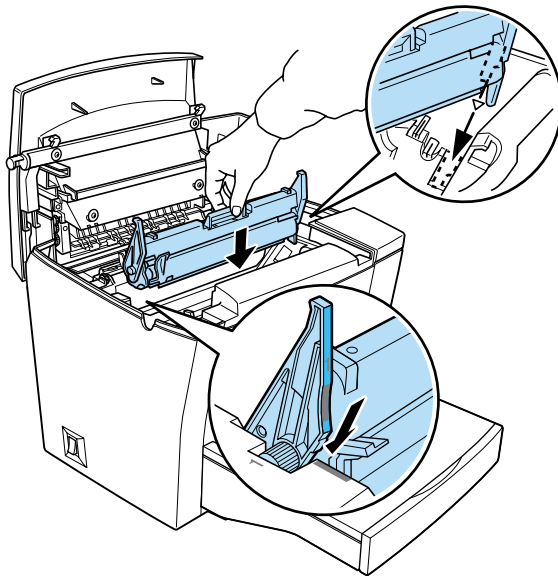

9. Reinstall the developer cartridge.
10. Lower the printer cover. Press it gently until it clicks shut.

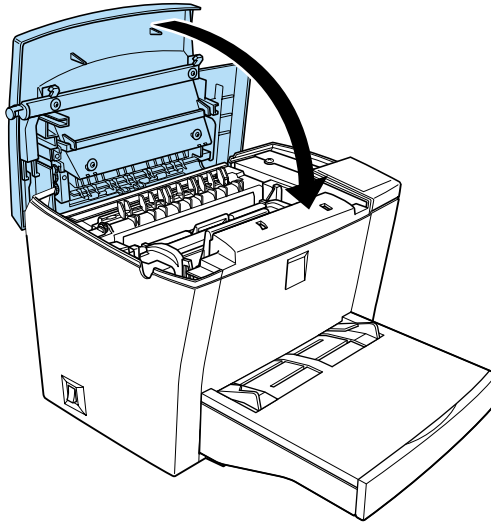

11. When you turn on the printer, access the Printer Settings dialog box in the Optional Settings tab of the printer driver of Windows, or click the Setup button in the Chooser dialog box, and click the Printer Settings in Macintosh. Click OPC Level Clear button. The OPC Level Clear dialog box appears.

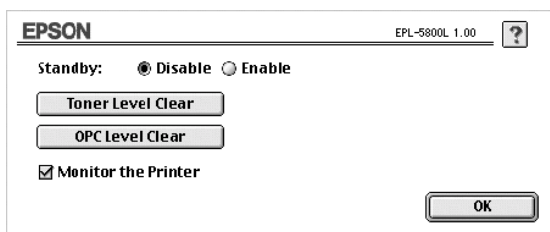
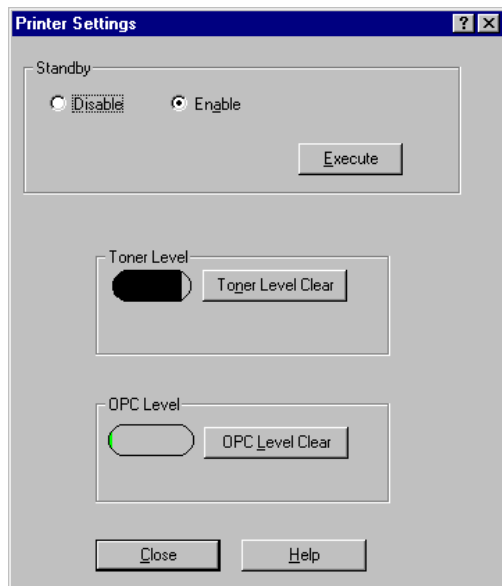

12. Click OK to reset the Photoconductor level counter.

Chapter 6

Troubleshooting

Ready and Error Lights	88
Problems and Solutions	89
Preventing paper-feed and paper-jam problems	89
Clearing paper jams	90
Operational problems	100
Printout problems	101
Print quality problems	102
Memory problems	107
Option problems	108
Printer driver and utility problems	109
Communication errors	110

Ready and Error Lights

The ready (green) and error (red) lights on the top of the printer may be the first indication of trouble. The status of the lights, on, off or flashing, indicates your printer status, as described below. The Status Alert window in the EPSON Status Monitor 3 utility indicates what type of error has occurred and offers you a possible solution. Look through this section to find the kind of problem you have, then try the recommended solutions in the order they are presented until your problem is solved.

Ready Light (green)	Error Light (red)	Printer Status
Off	Off	Printer is off.
On	Off	Printer is ready to print.
Flashing	Off	Printer is warming up or receiving data.
Off	Flashing	Either the printer is out of paper or there is an error that can be easily remedied.
Flashing	On	
Off	On	An error has occurred. Try turning off the printer and then turning it back on. If this does not clear the error, contact your dealer or a qualified service person.
Flashing alternately.		

Note:

If the problem remains after trying the suggestions in this section, contact your dealer for assistance.

Problems and Solutions

Look through this section to find the type of problem you have, and try the recommended solutions in the order they are presented. You will also be alerted to errors by the Status Alert window of the EPSON Status Monitor 3 utility according to the settings you make in the Monitoring Preferences dialog box. In addition, indicator lights on the printer's built-in control panel will light up in different combinations to inform you of basic printer status, errors and warnings. See "Ready and Error Lights" on page 88 for more information.

Note:

If the problem remains after trying the suggestions in this section, contact your dealer for assistance.

Preventing paper-feed and paper-jam problems

If you have frequent paper-feed or paper-jam problems, the suggestions listed below can help eliminate them.

- Fan the stack of paper and then tap its edges to align the paper before loading.
- Do not load more than the recommended amount of paper.
- Be sure to adjust the paper guides so that paper feeds freely.
- Never allow more than 100 sheets to accumulate on the face-down tray, or more than 20 sheets to accumulate on the Face-up Tray.
- Try turning over the stack of paper in the paper-tray. Most paper packages indicate which side is best for printing.

Clearing paper jams

If the jammed sheet is inside the printer, remove the sheet as follows:

1. Make sure that the printer is turned off.
2. Close the output tray, and open the printer cover by pressing the latch on the left side of the printer and lifting the cover up all the way.

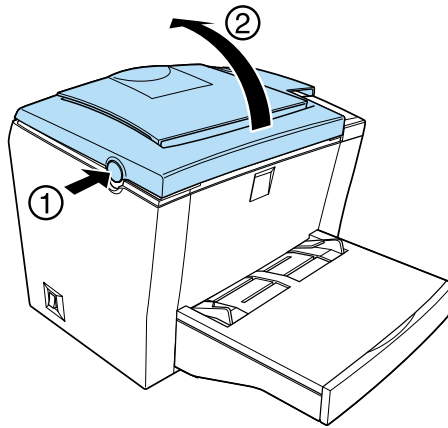



Warning:

Opening the printer cover exposes the fuser, which is marked CAUTION Hot Surface Avoid Contact. Be careful not to touch the fuser. If the printer has been in use, the fuser may be very hot.

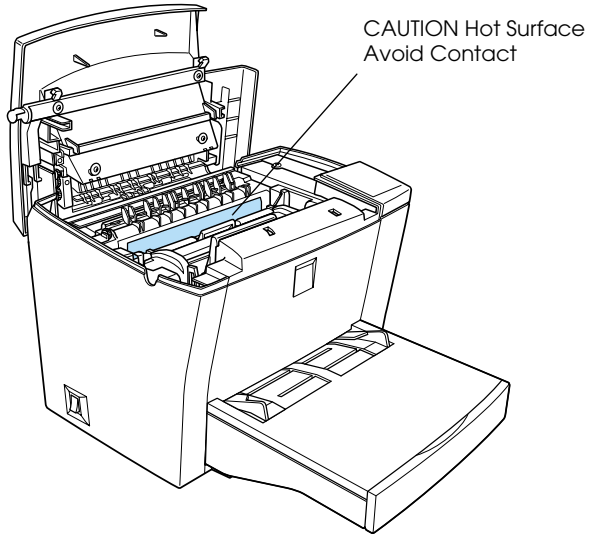

3. Remove the developer cartridge.

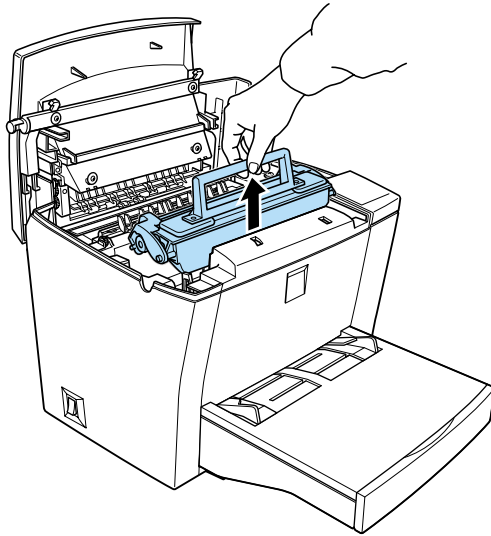

Caution:

When removing the developer cartridge, never touch the developing roller under the flap; otherwise, print quality may decline.

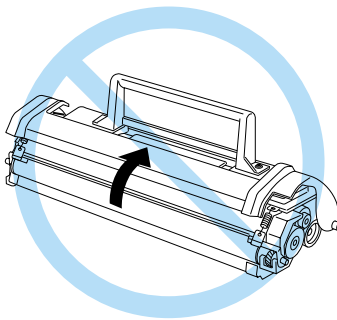

4. Remove the photoconductor unit.

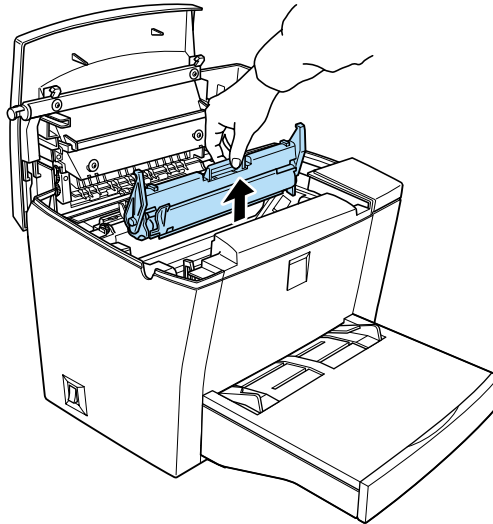

Caution:

Never touch the photoconductor unit's light-sensitive drum; otherwise, print quality may decline.

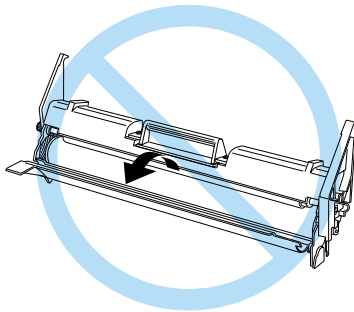

5. Remove the paper from the paper path.

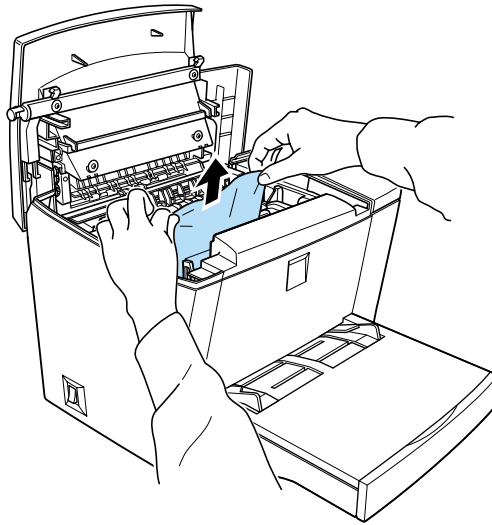

Note:

If paper is jammed at the fuser, grasp the bottom of the paper and pull it out.

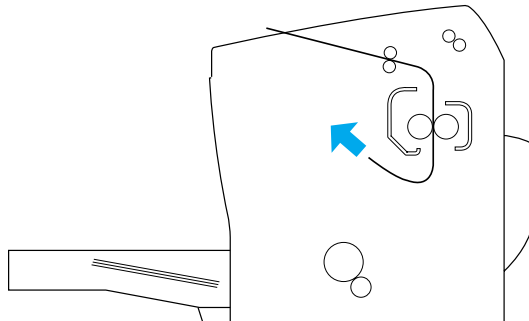

6. Reinstall the photoconductor unit, and then the developer cartridge.
7. Close the printer cover.
8. Tap the edges of the stack of paper on a flat surface and carefully reload it into the MP tray. (Do not reload curled or wrinkled sheets.)

Printing automatically restarts from the page that jammed. If the error light (red) continues flashing after removing all jammed paper, open and close the printer cover to clear the error.

Feed jam occurs at the MP tray

The following illustration shows what this type of jam looks like:

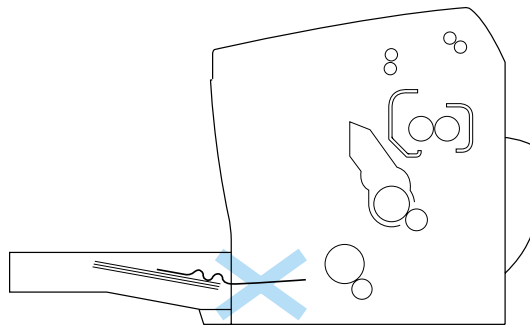

Follow the steps below to clear a feed jam at the MP tray:

1. Remove the MP tray cover and any stacked paper.

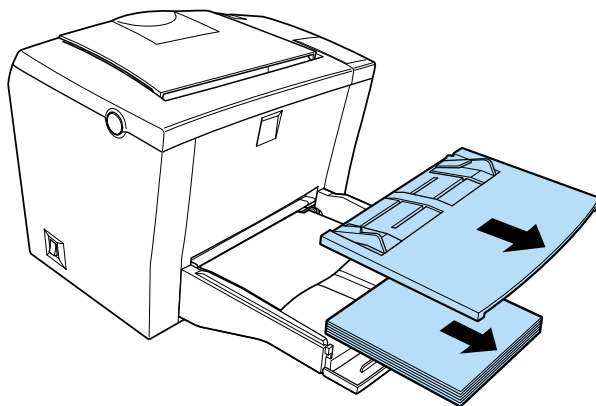

2. Gently pull out any sheets that have fed part way into the printer.

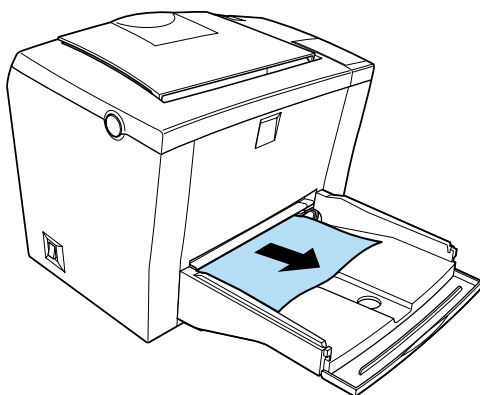

3. Open the printer cover. Be sure to remove any pieces of paper that may have torn off or are remaining in the printer.

If necessary, take out the developer cartridge and the photoconductor unit and remove any paper left in the paper feed path. Reinsert the unit and then the cartridge.

4. Tap the edges of the paper stack on a flat surface and carefully reload it. (Do not reload curled or wrinkled sheets.)
5. Reinstall the MP tray cover.
6. Close the printer cover. The jammed page's print data is automatically reprinted.

Feed jam occurs when using the optional 500-Sheet Lower Paper Cassette Unit

The following illustration shows what this type of jam looks like:

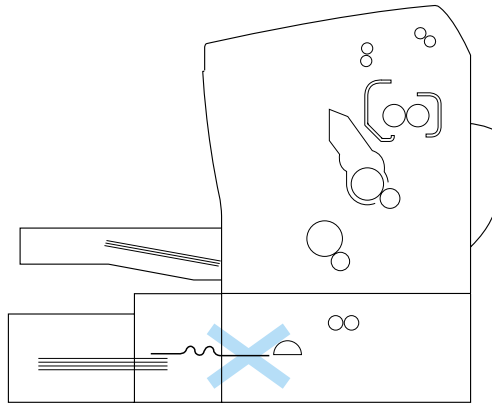

Follow the steps below to clear a feed jam in the 500-Sheet Lower Paper Cassette Unit:

1. Remove the paper-tray from the 500-Sheet Lower Paper Cassette Unit.

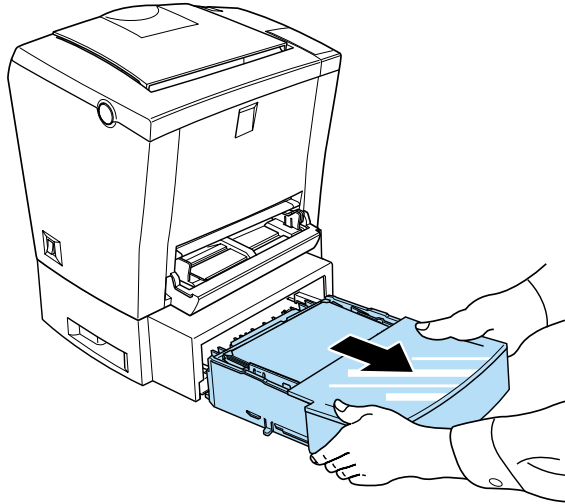

2. Remove any folded or jammed paper from the paper-tray and from the inside of the cassette unit, and discard any curled or wrinkled sheets.

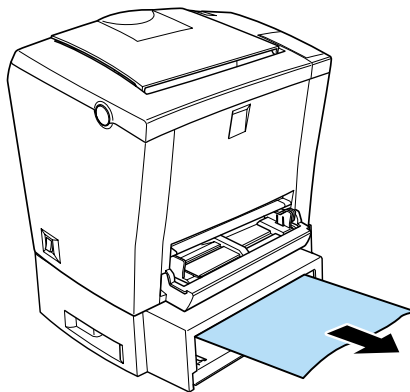

3. Remove all paper from the paper-tray and press down on the plate until it locks into position.

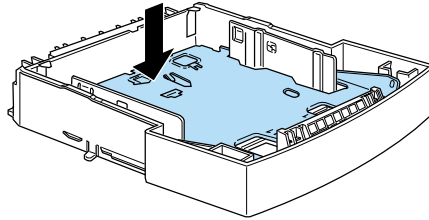

4. Tap the edges of the paper stack, then set it back into the paper-tray, making sure the paper is evenly aligned and that the top sheet is below the maximum paper mark.
5. Make sure you are using the correct paper size. The tray can accommodate only A4 or Letter size paper, depending on the country where you purchased the option. Also make sure you are using paper that meets the specifications for this printer.
6. Set the paper-tray back into the 500-Sheet Lower Paper Cassette Unit.
7. Open and then close the printer cover. The jammed page's print data is automatically reprinted.

Operational problems

The Ready light (green) does not turn on when you turn the printer on

Turn off the printer and check the power cord connection between the printer and the electrical outlet. Then turn the printer back on.

If the electrical outlet is controlled by an outside source such as a wall switch, make sure the switch is turned on. Try plugging another electrical device into the outlet to check whether the outlet is operating properly.

The Ready light is on but nothing prints

Your computer may not be properly connected to the printer. Perform the procedure described in “Connecting to the Computer” in the *Setup Guide*.

The interface cable may not be plugged in securely. Check both ends of the cable between the printer and the computer. If connecting through the parallel interface, be sure to secure the connector using the wire retaining clips.

Make sure you use a double-shielded, twisted-pair interface cable no more than six feet in length.

The developer cartridge may be empty. To replace the cartridge, see “Replacing the Developer Cartridge” on page 77.

Printout problems

Some or all of the printout is garbled or printed as asterisks

Make sure that both ends of the interface cable are plugged in securely.

If connecting through the parallel interface, make sure you use a double-shielded, twisted-pair interface cable no more than six feet in length.

If the printer still does not print correctly, contact your dealer or a qualified service representative.

Position of the printout is not correct

Make sure that you are using the correct page length and margin settings and offset settings in your application program.

Graphics don't print correctly

Graphics require large amounts of memory. See "Memory problems" on page 107.

Light color is not printed

If colored areas or light-colored text or graphics are not printed, try changing the selected color or print at 300 dpi resolution.

Print quality problems

The background is dark or dirty

Lighten the Density setting in the printer driver.

Turn off the printer and clean the paper path inside the printer using a clean, dry, lint-free cloth.

Clean the internal printer components by printing three pages with only one character per page.

You may not be using the correct type of paper for your printer. If the surface of your paper is too rough, printed characters may appear distorted or broken. Smooth, high-quality copier paper is recommended for best results. See “Specifications” on page 119 for information on choosing paper.

There may be a problem with the developer cartridge. Remove the cartridge and shake it gently from side to side and then from front to back to distribute the toner evenly, then reinstall it. If the problem persists, replace the developer cartridge. For more information, see “Replacing the Developer Cartridge” on page 77.

You may need to replace the photoconductor unit. See “Replacing the Photoconductor Unit” on page 82 for instructions.

Black or white bands appear in the printout

Turn off the printer. Clean the paper path inside the printer using a soft, dry, lint-free cloth.

Clean the internal printer components by printing three pages with only one character per page.

There may be a problem with the developer cartridge. Remove the cartridge and shake it gently from side to side and then from front to back to distribute the toner evenly, then reinstall it. If this does not solve the problem, see “Replacing the Developer Cartridge” on page 77.

You may need to replace the photoconductor unit. See “Replacing the Photoconductor Unit” on page 82 for instructions.

Uneven image density

- Your paper may be moist or damp. Do not store paper in a humid or damp environment.
- Make sure the paper type is correct.
- Check that the Toner Save mode is turned on.
- Confirm that the density setting is light.
- Turn off the printer. Take out the developer cartridge, shake it gently from side to side and then from front to back to distribute the toner evenly, and then reinstall it.

If this does not solve the problem, install a new cartridge. For more information, see “Replacing the Developer Cartridge” on page 77. Then print several pages to check the print quality.

Toner smudges

Your paper may be moist or damp. Do not store paper in a humid or damp environment.

You may not be using the correct type of paper for your printer. If the surface of your paper is too rough, printed characters may appear distorted or broken. Smooth, high-quality copier paper is recommended for best results. See “Specifications” on page 119 for information on choosing paper.

Turn off the printer. Remove the developer cartridge, shake it from side to side to distribute the toner, and wipe the bottom of the cartridge with a clean, dry, lint-free cloth.

Clean the paper path inside the printer using a clean, dry, lint-free cloth.

Clean the internal printer components by printing three pages with only one character per page.

If the problem remains, replace the developer cartridge. For more information, see “Replacing the Developer Cartridge” on page 77.

Missing areas on printed images

Your paper may be moist or damp. Printing is sensitive to moisture absorbed by the paper. The higher the moisture content of the paper, the lighter the printed output. Do not store paper in a humid or damp environment.

You may not be using the correct type of paper for your printer. If the surface of your paper is too rough, printed characters may appear distorted or broken. Smooth, high-quality copier paper is recommended for best results. See “Specifications” on page 119 for information on choosing paper.

Completely blank pages

Check the toner status using the EPSON Status Monitor 3 utility. If the status monitor displays the Toner Low message, you need to replace the developer cartridge. For instructions, see “Replacing the Developer Cartridge” on page 77.

To check that the photoconductor unit and the developer cartridge are correctly installed, see Chapter 5, “Replacing Consumables.”

The problem may be with your software program or your interface cable. Try printing a status sheet through the printer driver. If blank pages continue to print, the problem may be with the printer. Turn off the printer and contact your dealer.

The printed image is light or faint

Your paper may be moist or damp. The higher the moisture content of the paper, the lighter the printed output. Do not store paper in a humid or damp environment.

The Toner Save mode may be on. Turn off the Toner Save mode using the printer driver.

Darken the Density setting in the printer driver.

Turn off the printer. Take out the developer cartridge, shake it gently from side to side to distribute the toner, and then reinstall it. If the problem persists, see Chapter 5, “Replacing Consumables.”

The image is too dark

Lighten the Density setting in the printer driver.

If the problem persists, see Chapter 5, “Replacing Consumables.”

Non-printed side of the page is dirty

Toner may have spilled onto the paper feed path. Turn off the printer. Remove the developer cartridge and the photoconductor unit and then clean the paper path inside the printer using a clean, dry, lint-free cloth.



Warning:

Opening the printer exposes the fuser, which is marked by a CAUTION Hot Surface Avoid Contact label. Be careful not to touch the fuser. If the printer has been in use, the fuser may be very hot.

Memory problems

Insufficient memory for current task

Printing stops due to a lack of memory. To correct the error, Turn the printer off and back on again. If your computer cannot connect in ECP mode, the printer may not be able to print with the standard memory. For information on installing more memory, see “Memory Module” on page 67.

However, it may be necessary to reduce the number or size of fonts, reduce the number or size of graphics, lower the resolution, or add more memory to the printer.

Insufficient memory to print all copies

The printer does not have sufficient memory to collate print jobs. Only one set of copies will be printed. Reduce the content of print jobs, or add more memory. For information on installing more memory, see “Memory Module” on page 67.

Option problems

Paper does not feed from the optional 500-Sheet Lower Paper Cassette Unit

Make sure you have selected the correct paper source in your printer driver.

There may be no paper in the 500-Sheet Lower Paper Cassette Unit. Load it with paper.

Be sure that the 500-Sheet Lower Paper Cassette Unit is properly installed and that you have not tried to load it with too many sheets of paper. The cassette can hold a maximum of 500 sheets of 75 g/m² (20 lb) paper.

The 500-Sheet Lower Paper Cassette Unit may not be installed properly. See “500-Sheet Lower Paper Cassette Unit” on page 62 for instructions on installing the 500-Sheet Lower Paper Cassette Unit.

Feed jam occurs when using the optional 500-Sheet Lower Paper Cassette Unit

See “Feed jam occurs when using the optional 500-Sheet Lower Paper Cassette Unit” on page 97.

Printer driver and utility problems

The status information does not match the real status of the printer

EPSON Status Monitor 3 monitors the printer at regular intervals. You may need to wait until EPSON Status Monitor 3 monitors the printer again, and automatically updates the status.

Cannot install the printer driver in Windows

If your computer did not have Windows 98 pre-installed, it is an upgrade from Windows 95 to 98. It may not support USB connectors, and may not print. Confirm whether your computer supports USB connectors by calling the manufacturer.

The printer driver is installed as an “unknown device” in Device Manager

Some problem may have disrupted the plug-and-play installation of the printer driver. With the printer turned on and connected to the computer through a USB cable, right-click the My Computer icon and choose Properties. Click the Device Manager tab and check if USB printer or EPL-5800L appears under unknown device. If it does, disconnect the USB cable from the printer, reconnect it, and reinstall the printer driver.

Cannot print from Windows

The printer port setting may be incorrect. Confirm that the correct printer port is chosen in the Details tab of the printer driver's Properties dialog box.

Your printer is not displayed in the Printers folder

The computer does not recognize the printer connection. Make sure that the printer's power is on. If you are using the USB interface and your printer does not appear in the Printers folder, try disconnecting and then reconnecting the USB cable. If this does not resolve the problem, try reinstalling the printer driver. See the *Setup Guide* for more information.

Communication errors

Communication error

Check that the power cord is properly plugged into the electrical outlet and that the printer is turned on.

The printer may be initializing itself or running a self-test. Give the printer enough time to complete the initialization process.

Make sure that the printer is online and ready to print. The Ready light on the control panel is on and not flashing when the printer is online.

Windows shared printers cannot be monitored

Monitoring of shared printers is set internally by the EPSON Status Monitor 3 utility. To monitor Windows shared printers, right-click Network Neighborhood and then click Properties. Verify that File and printer sharing for Microsoft Networks is shown in the list of installed components.

Also, verify that EPSON Status Monitor 3 is installed in the computer hosting the Windows shared printer, and be sure that the Allow monitoring of shared printers check box is selected in the Monitoring Preferences dialog box.

In Windows Me, 98, and 95, IPX/SPX compatible protocols cannot be set on the network module.

Although connected to the USB hub, the printer does not operate correctly

The printer may not be connected to the first level USB hub. There are five levels of USB connectors, make sure that your printer is connected to the first level.

Make sure that the computer has correctly recognized the USB hub. Check the USB hub under universal serial bus in the device manager.

Chapter 7

Cleaning and Transporting the Printer

Cleaning the Printer	113
Cleaning the inside of the printer	113
Removing spilled toner	115
Cleaning the printer case	116
Transporting the Printer	117

Cleaning the Printer

The printer needs only minimal cleaning. If you notice a decline in print quality, clean the inside of the printer as described in this section.

You should also clean the MP tray and the printer case every few months.

Cleaning the inside of the printer

Fine particles of dust can collect inside the printer, affecting print quality. Follow the steps below to clean the inside of the printer and the paper feeder:

1. Make sure the printer is turned off.
2. Open the printer cover by pressing the latch on the left side of the printer and lifting the cover up all the way.



Warning:

Opening the printer exposes the fuser, which is marked CAUTION Hot Surface Avoid Contact. Be careful not to touch the fuser. If the printer has been in use, the fuser may be very hot.

3. Remove the developer cartridge and the photoconductor unit as described in Chapter 5, “Replacing Consumables.”

4. Remove any dirt inside the printer with a clean, dry, lint-free cloth. Do not use compressed air. If you have paper feed problems, clean the paper roller by opening the roller cover and wiping the roller with a clean, dry, lint-free cloth.

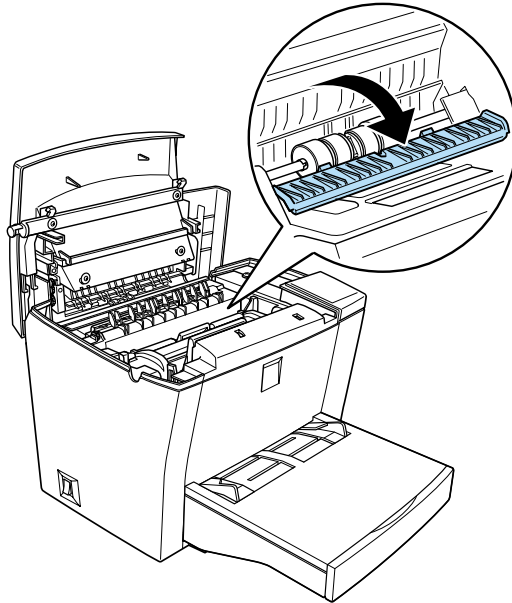

5. Reinstall the photoconductor unit, and then the developer cartridge.
6. Lower the printer cover. Press it gently until it clicks shut.
7. Remove all paper from the MP tray and clean the tray with a clean, dry, lint-free cloth.

Removing spilled toner

If toner spills inside the printer, do not use the printer until you remove all the spilled toner.

If only a small amount of toner is present, carefully wipe out the inside of the printer with a clean, dry, lint-free cloth.

If a large amount of toner is present, use a small vacuum-cleaning device (available from computer supply stores) to remove it. Then carefully wipe with a clean, dry, lint-free cloth.



Caution:

Toner and other fine powders can damage some vacuum cleaners. Be sure to read the instructions for your vacuum cleaner before you use it on spilled toner.

Note:

If you spill toner on your clothing, rinse it off with cold water. Do not use hot water as this may cause the toner to leave a permanent stain.

Cleaning the printer case

If the printer's outer case is dirty or dusty, turn off the printer and clean it with a clean, dry, lint-free cloth dampened with a mild detergent.

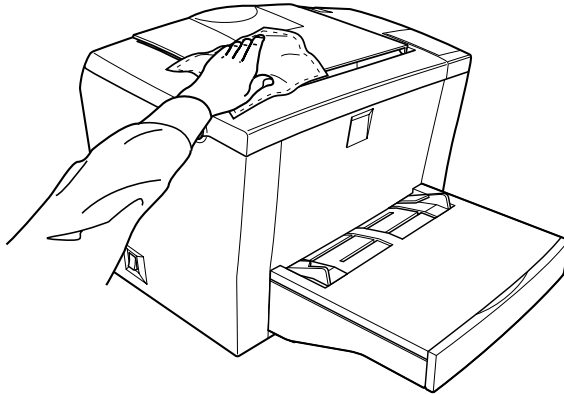

Caution:

Never use alcohol or thinner to clean the printer case; these chemicals can damage the components and the case. Be careful not to get water onto the printer mechanism or any electronic components.

Transporting the Printer

If you need to transport your printer, carefully repack it using the original box and packing materials as follows:

1. Turn off the printer.
2. Unplug the power cord from the electrical outlet and then from the printer.
3. Disconnect all interface cables from the printer.
4. Lift off the MP tray cover and remove all paper from the tray.
5. Grasp the base part of the MP tray with both hands, press inward on the edges, and pull it out of the printer.

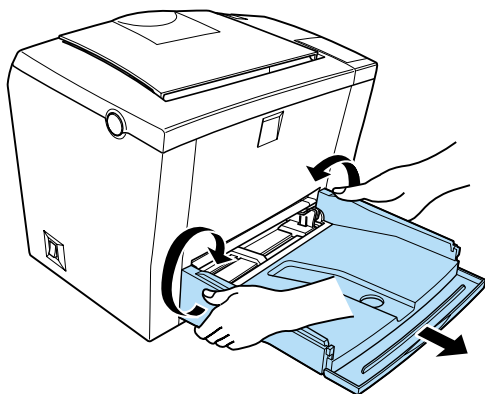

6. Remove the optional 500-Sheet Lower Paper Cassette Unit, if installed.
7. Replace the printer's protective materials, then repack the printer in its original box.



Caution:

Do not expose the photoconductor unit and the developer cartridge to light any longer than necessary.

Technical Specifications

Paper119
 Specifications.....119

Printer121
 General121
 Environmental.....122
 Safety approvals122
 Mechanical.....123
 Electrical.....123

Interface.....124
 Parallel interface124
 USB interface124

Options and Consumables125
 500-Sheet Lower Paper Cassette Unit (C81336*).....125
 Face-up Tray (C813372)126
 Developer cartridge (S050010)126
 Photoconductor unit (S051055).....127

Paper

Specifications

Note:

Since the quality of any particular brand or type of paper may be changed by the manufacturer at any time, EPSON cannot guarantee the quality of paper. Always test samples of paper stock before purchasing large quantities or printing large jobs.

Paper Types: Plain paper, recycled paper, labels, envelopes, transparencies, colored paper, thick paper, card stock, letterhead

Note:

Use recycled paper under normal temperature and humidity conditions only. Poor-quality paper may reduce print quality, cause paper jams and other problems.

Paper weight:

Plain paper	60 to 90 g/m ² (16 to 24 lb*)
Card stock	90 to 163 g/m ² (24 to 43.4 lb)

* lb: Ream Weight (lb/500 sheets/17 in. × 22 in.)

Paper size:

Paper	A4 (210 × 297 mm)
	A5 (148 × 210 mm)
	B5 (182 × 257 mm)
	Letter (216 × 279mm, 8.5 × 11 in.)
	Half Letter (140 × 216mm, 5.5 × 8.5 in.)
	Legal (216 × 356 mm, 8.5 × 14 in.)
	Executive (184 × 267 mm, 7.25 × 10.5 in.)
	Government Legal (216 × 330 mm, 8.5 × 13 in.)
	Government Letter (203 × 267 mm, 8 × 10.5 in.)
	F4 (210 × 330 mm, 8.3 × 13 in.)
	User Defined Size (76.2 × 127 mm to 216 × 355.6 mm, 3 × 5 in. to 8.5 × 14 in.)
Envelopes	Monarch (98 × 191 mm, 3.9 × 7.5 in.)
	Commercial 10 (105 × 241 mm, 4.1 × 9.5 in.)
	DL (110 × 220 mm, 4.3 × 8.7 in.)
	C5 (162 × 229 mm, 6.4 × 9 in.)
	C6 (114 × 162 mm, 4.5 × 6.4 in.)
	International B5 (176 × 250 mm, 7 × 9.8 in.)



Caution:

Only load paper sizes that are listed above.

Printable area: The area on a page contained within a 4-mm minimum margin on all sides

Printer

General

Printing method:	Laser beam scanning and dry electrophotographic process
Resolution:	600 × 600 dpi, 300 × 300 dpi
Printing speed:	Up to 10 pages per minute at 600/300 dpi, depending on the font and quantity of data
First print:	Less than 18 seconds with A4 or Letter size paper
Warm-up time:	About 22 seconds at normal temperature
Paper feed:	Automatic
Paper feed alignment:	Center alignment for all sizes
Input paper supply (75g/m ² paper):	Up to 150 sheets in the MP tray Up to 500 sheets in the optional 500-Sheet Lower Paper Cassette Unit Up to 10 envelopes, depending on thickness
Paper output:	Face-down or Face-up (optional) selection
Paper output capacity (75g/m ² paper):	Up to 100 sheets for face-down output Up to 20 sheets for face-up output with the optional Face-up Tray
RAM:	2 MB, expandable up to 13 MB

Environmental

Temperature:	Operation:	10 to 35 °C (50 to 95 °F)
	Storage:	0 to 35 °C (32 to 95 °F)
Humidity:	Operation:	15 to 85% RH
	Storage:	30 to 85% RH
Altitude:	Maximum 2,500 meters (8,200 feet)	

Standards and Approvals

U.S. model:

Safety	UL 1950 CSA C22.2 No.950
EMC	FCC Part 15 subpart B class B CSA C108.8 Class B

European model:

Low Voltage Directive 73/23/EEC	EN60950
EMC Directive 89/336/EEC	EN 55022 Class B EN 50024 EN 61000-3-2 EN 61000-3-3

Australian model:

EMC	AS/NZS 3548 Class B
-----	---------------------

Mechanical

Dimensions and

weight:	Height:	338 mm (13.3 in.)
	Width:	387 mm (15.2 in.)
	Depth:	475 mm (18.7 in.)
	Weight:	Approx. 7.0 kg (15.4 lb), excluding the developer cartridge and the photoconductor unit

Durability: 5 years or 180,000 sheets, whichever comes first

Electrical

	110 V model	230 V model
Voltage	90 V to 132 V	198 V to 264 V
Rated frequency	50 Hz \pm 3 Hz/ 60 Hz \pm 3 Hz	50 Hz \pm 3 Hz/ 60 Hz \pm 3 Hz
Rated current	5.9 A	3.2 A
Power consumption	Less than 690 W	Less than 700 W
Power consumption* in Standby mode	Less than 10 W	Less than 10 W

* No options installed



Caution:

Check the label on the back of the printer for its specified voltage.

Interface

Parallel interface

Use only an IEEE 1284-B compliant parallel connector.

To use the ECP mode with the parallel connector, see “Using the ECP mode” on page 51.

Note:

Windows Me/98/95/2000/NT 4.0 support the parallel interface.

USB interface

Windows USB Plug and Play (PnP) compliant.

Note:

Only Macintosh and PC systems equipped with a USB connector and running Mac OS 8.1 (or later) and Windows Me/98/2000 support the USB interface.

Options and Consumables

Note:

The asterisk (*) in product numbers is a substitute for the last digit of the product number, which varies by country.

500-Sheet Lower Paper Cassette Unit (C81336*)

Paper size:	A4 or Letter, depending on the country of purchase
Paper weight:	60 to 90 g/m ² (16 to 24 lb)
Paper feed:	Automatic feed delivery system Tray capacity of up to 500 sheets (75 g/m ² or 20 lb paper)
Paper feed speed:	For the first sheet, 19 seconds or less; subsequent sheets, 10 pages per minute
Paper types:	Plain paper, such as copier paper, and recycled paper
Power supply:	5 V dc supplied by the printer
Dimensions and weight:	4.0 kg (8.8 lb) including the tray
Height	124.5 mm (4.9 in.)
Width	380 mm (15 in.)
Depth	460 mm (18.1 in.) including the tray
Weight	4.0 kg (8.8 lb) including the tray

Face-up Tray (C813372)

Dimensions and weight (including printer):

Height	35 mm (16.5 in.)
Width	239 mm (15.2 in.)
Depth	243 mm (23.4 in.)
Weight	0.2 kg (0.44 lb)

Paper output capacity: 20 sheets (75 g/m² or 20 lb paper)

Developer cartridge (S050010)

Storage temperature: 0 to 35 °C (32 to 95 °F)

Storage humidity: 30 to 85% RH

Shelf life: 18 months after production

Life: Up to 6,000 pages under the following conditions: Letter or A4 size paper, continuous printing, 5% print ratio

Photoconductor unit (S051055)

Storage temperature:	0 to 35 °C (32 to 95 °F)
Storage humidity:	30 to 85% RH
Shelf life:	18 months after production
Life:	Up to 20,000 pages under the following conditions: Letter or A4 size paper, continuous printing, 5% print ratio

The number of pages you can print with a developer cartridge or a photoconductor unit varies depending on the type of printing. If you print a few pages at a time or print dense text exceeding the 5% print ratio, the cartridge and/or unit may print fewer pages. The 5% print ratio is equivalent to printing double-spaced standard text.

Working with Fonts

EPSON BarCode Fonts129
 System requirements130
 Installing EPSON BarCode fonts131
 Printing with EPSON BarCode fonts133
 BarCode Font specifications136

EPSON BarCode Fonts

EPSON BarCode fonts let you easily create and print many types of barcodes.

Normally, barcode creation is a laborious process requiring you to specify various command codes, such as Start bar, Stop bar and OCR-B, in addition to the barcode characters themselves.

However, EPSON BarCode fonts are designed to add such codes automatically, allowing you to easily print barcodes that conform to a variety of barcode standards.

EPSON BarCode fonts support the following types of barcodes:

Barcode Standard	EPSON BarCode	OCR-B	Check Digit	Comments
EAN	EPSON EAN-8	Yes	Yes	Creates EAN (abbreviated version) barcodes.
	EPSON EAN-13	Yes	Yes	Creates EAN (standard version) barcodes.
UPC-A	EPSON UPC-A	Yes	Yes	Creates UPC-A barcodes.
UPC-E	EPSON UPC-E	Yes	Yes	Creates UPC-E barcodes.
Code 39	EPSON Code 39	No	No	Printing of OCR-B and check digits can be specified with the font name.
	EPSON Code 39 CD	No	Yes	
	EPSON Code 39 CD Num	Yes	Yes	
	EPSON Code 39 Num	Yes	No	
Code 128	EPSON Code 128	No	Yes	Creates Code 128 barcodes.

Barcode Standard	EPSON BarCode	OCR-B	Check Digit	Comments
Interleaved 2 of 5 (ITF)	EPSON ITF	No	No	Printing of OCR-B and check digits can be specified with the font name.
	EPSON ITF CD	No	Yes	
	EPSON ITF CD Num	Yes	Yes	
	EPSON ITF Num	Yes	No	
Codabar	EPSON Codabar	No	No	Printing of OCR-B and check digits can be specified with the font name.
	EPSON Codabar CD	No	Yes	
	EPSON Codabar CD Num	Yes	Yes	
	EPSON Codabar Num	Yes	No	

System requirements

To use EPSON BarCode fonts, your computer system should meet the following requirements:

Printer: EPL-5800L/EPSON AcuLaser C8500/
 EPSON AcuLaser C2000/
 EPSON EPL-5800/EPL-5700i/
 EPL-5700L/EPL-N2750/EPL-C8200/
 EPL-N4000+/EPL-N2050 or later printers
 which have EPSON BarCode fonts

Computer: IBM PC series or IBM compatible with an
 i386SX or higher CPU

Operating system: Microsoft Windows Me, 98, 95, 2000, NT 4.0,
 3.5x

Hard disk:	15 to 30 KB free space, depending on the font.
Printer driver:	EPL-5800L Advanced, EPSON AL-C8500 Advanced/EPSON AL-C2000 Advanced, EPL-5800 Advanced, EPL-N2750 Advanced, EPL-C8200 Advanced, EPL-N4000+ Advanced, EPL-N2050 Advanced or later drivers which have EPSON BarCode fonts

Note:

EPSON BarCode fonts can only be used with EPSON printer drivers.

Installing EPSON BarCode fonts

Follow these steps to install EPSON BarCode fonts. The procedure described here is for installation in Windows NT 4.0; the procedure for other Windows operating systems is nearly the same.

1. Turn on the computer and start Windows.
2. Insert the CD-ROM or floppy disk containing the BarCode fonts into the appropriate drive.
3. Click Start, point to Settings, then click Control Panel.
4. Double-click Fonts.

5. From the File menu, select Install New Font.

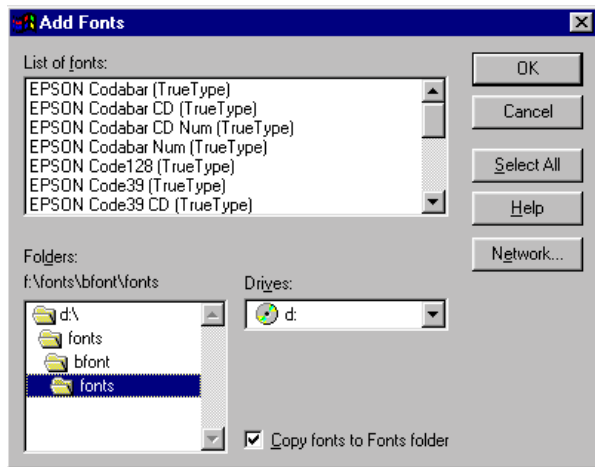

6. Select the appropriate CD-ROM or floppy drive, then select the BarCode Fonts folder from the Folders list.
7. In the List of fonts box, select the BarCode Font you want to install, or click the Select All button to install all EPSON BarCode fonts.
8. Select Copy fonts to Fonts folder check box.
9. Click OK. The selected EPSON BarCode fonts are installed in the Windows Fonts folder.

Printing with EPSON BarCode fonts

Follow these steps to create and print barcodes using EPSON BarCode fonts. The application featured in these instructions is Microsoft WordPad. The actual procedure may differ slightly when printing from other applications.

1. Open a document in your application and enter the characters you want to convert to a barcode.

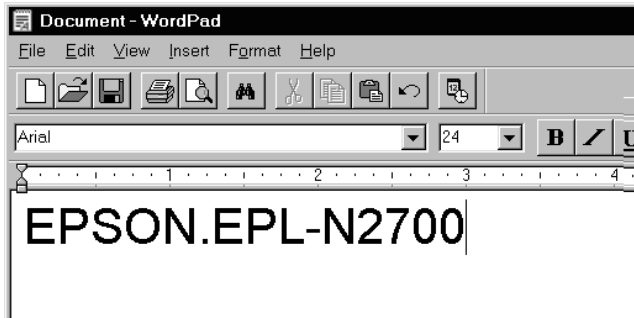

2. Select the characters, then select FONT from the Format menu.



3. Select the EPSON BarCode Font you want to use, then set the font size and click OK.

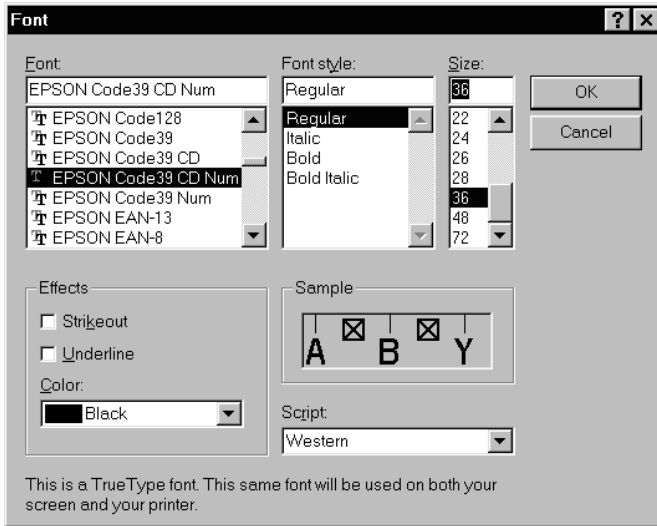

Note:

In Windows NT 4.0, you cannot use font sizes larger than 96 points when printing barcodes.

4. The characters you selected appear as barcodes similar to those shown below.

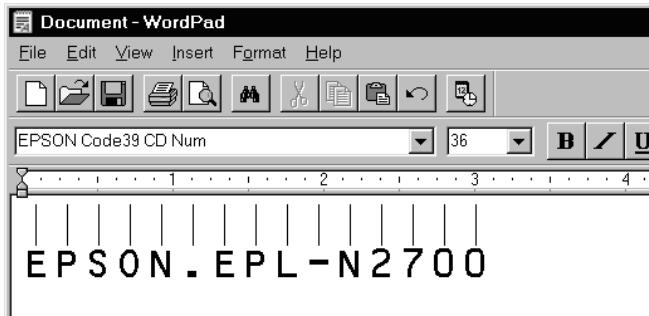

5. Select Print from the File menu, then select your EPSON printer and click Properties. Make the following printer driver settings:

Print Quality	600 dpi
Toner Save mode	Off
Zoom Options	Unchecked

6. Click OK to print the barcode.

Note:

If there is an error in the barcode character string, such as inappropriate data, the barcode will be printed as it appears on the screen, but it cannot be read by a barcode reader.

Notes on inputting and formatting barcodes

Please note the following when inputting and formatting barcode characters:

- Do not apply shading or special character formatting, such as bold, italic, or underline.
- Print barcodes in black and white only.
- When rotating characters, only specify rotation angles of 90°, 180° and 270°.
- Turn off all automatic character and word spacing settings in your application.
- Do not use features in your application which enlarge or reduce the size of characters in only the vertical or horizontal direction.
- Turn off your application's auto-correct features for spelling, grammar, spacing, etc.

- ❑ To more easily distinguish barcodes from other text in your document, set your application to show text symbols, such as paragraph marks, tabs, etc.
- ❑ Because special characters such as Start bar and Stop bar are added when an EPSON BarCode Font is selected, the resulting barcode may have more characters than were originally input.
- ❑ For best results, use only the font sizes recommended in “BarCode Font specifications” on page 136 for the EPSON BarCode Font you are using. Barcodes in other sizes may not be readable with all barcode readers.

Note:

Depending on the print density, or on the quality or color of the paper, barcodes may not be readable with all barcode readers. Print a sample and make sure the barcode can be read before printing large quantities.

BarCode Font specifications

This section contains details on the character input specifications for each EPSON BarCode Font.

EPSON EAN-8

- EAN-8 is an eight-digit abbreviated version of the EAN barcode standard.
- Because the check digit is added automatically, only 7 characters can be input.

Character type	Numbers (0 to 9)
Number of characters	Up to 7 characters
Font size	52 pt to 130 pt (up to 96 pt in Windows NT). Recommended sizes are 52 pt, 65 pt (standard), 97.5 pt and 130 pt.

The following codes are inserted automatically and need not be input by hand:

- Left/right margin
- Left/right guard bar
- Center bar
- Check digit
- OCR-B

Print Sample

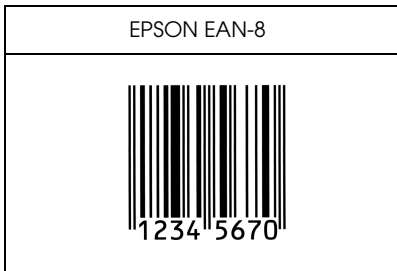

EPSON EAN-13

- EAN-13 is the standard 13-digit EAN barcode.
- Because the check digit is added automatically, only 12 characters can be input.

Character type	Numbers (0 to 9)
Number of characters	Up to 12 characters
Font size	60 pt to 150 pt (up to 96 pt in Windows NT). Recommended sizes are 60 pt, 75 pt (standard), 112.5 pt and 150 pt.

The following codes are inserted automatically and need not be input by hand:

- Left/right margin
- Left/right guard bar
- Center bar
- Check digit
- OCR-B

Print Sample

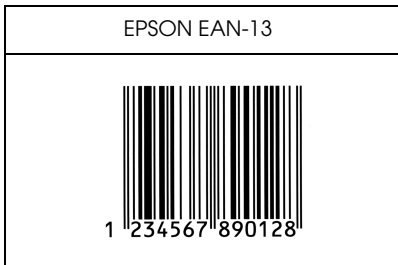

EPSON UPC-A

- UPC-A is the UPC-A standard barcode specified by the American Universal Product Code (UPC Symbol Specification Manual).
- Only regular UPC codes are supported. Supplementary codes are not supported.

Character type	Numbers (0 to 9)
Number of characters	Up to 11 characters
Font size	60 pt to 150 pt (up to 96 pt in Windows NT). Recommended sizes are 60 pt, 75 pt (standard), 112.5 pt and 150 pt.

The following codes are inserted automatically and need not be input by hand:

- Left/right margin
- Left/right guard bar
- Center bar
- Check digit
- OCR-B

Print Sample

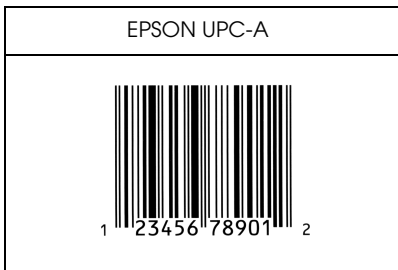

EPSON UPC-E

- UPC-E is the UPC-A zero-suppression (deletes extra zeros) barcode specified by the American Universal Product Code (UPC Symbol Specification Manual).

Character type	Numbers (0 to 9)
Number of characters	Up to 6 characters
Font size	60 pt to 150 pt (up to 96 pt in Windows NT). Recommended sizes are 60 pt, 75 pt (standard), 112.5 pt and 150 pt.

The following codes are inserted automatically and need not be input by hand:

- Left/right margin
- Left/right guard bar
- Check digit
- OCR-B
- The numeral "0"

Print Sample

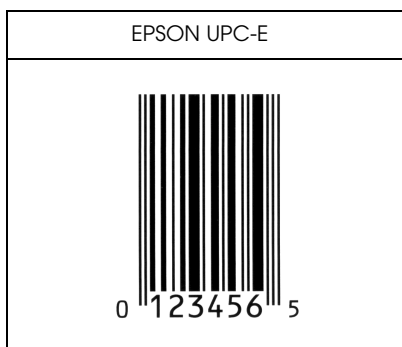

EPSON Code39





- ❑ Four Code39 fonts are available, allowing you to enable and disable the automatic insertion of check digits and OCR-B.
- ❑ The height of the barcode is automatically adjusted to 15% or more of its total length, in conformance to the Code39 standard. For this reason, it is important to keep at least one space between the barcode and the surrounding text to prevent overlapping.
- ❑ Spaces in Code39 barcodes should be input as “_” underbars.
- ❑ When printing two or more barcodes on one line, separate the barcodes with a tab, or select a font other than a BarCode Font and input the space. If a space is input while a Code39 font is selected, the barcode will not be correct.

Character type	Alphanumeric characters (A to Z, 0 to 9) Symbols (- . space \$ / + %)
Number of characters	No limit
Font size	When OCR-B is not used: 26 pt or more (up to 96 pt in Windows NT) Recommended sizes are 26 pt, 52 pt, 78 pt and 104 pt. When OCR-B is used: 36 pt or more (up to 96 pt in Windows NT) Recommended sizes are 36 pt, 72 pt, 108 pt and 144 pt.

The following codes are inserted automatically and need not be input by hand:

- ❑ Left/right quiet zone
- ❑ Check digit
- ❑ Start/Stop character

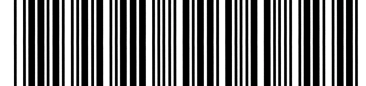
Print Sample

EPSON Code39	EPSON Code39 CD
	
EPSON Code39 Num	EPSON Code39 CD Num
 1 2 3 4 5 6 7	 1 2 3 4 5 6 7 S

EPSON Code128

- ❑ Code128 fonts support code sets A, B, and C. When the code set of a line of characters is changed in the middle of the line, a conversion code is automatically inserted.
- ❑ The height of the barcode is automatically adjusted to 15% or more of its total length, in conformance to the Code128 standard. For this reason, it is important to keep at least one space between the barcode and the surrounding text to prevent overlapping.
- ❑ Some application software automatically deletes the spaces at the end of lines or changes multiple spaces into tabs. Barcodes containing spaces may not be correctly printed from applications that automatically delete spaces from the ends of lines or change multiple spaces into tabs.

- ❑ When printing two or more barcodes on one line, separate the barcodes with a tab, or select a font other than a BarCode Font and input the space. If a space is input while Code128 is selected, the barcode will not be correct.

Character type	All ASCII characters (95 in total)
Number of characters	No limit
Font size	26 pt to 104pt (up to 96 pt in Windows NT.) Recommended sizes are 26 pt, 52 pt, 78 pt and 104 pt.

The following codes are inserted automatically and need not be input by hand:

- ❑ Left/right quiet zone
- ❑ Start/Stop character
- ❑ Check digit
- ❑ Change code set character

Print Sample

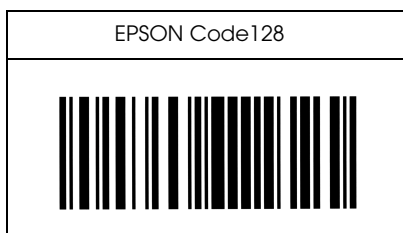

EPSON ITF

- ❑ The EPSON ITF fonts conform to the USS Interleaved 2-of-5 standard (American).
- ❑ Four EPSON ITF fonts are available, allowing you to enable and disable the automatic insertion of check digits and OCR-B.
- ❑ The height of the barcode is automatically adjusted to 15% or more of its total length, in conformance to the Interleaved 2-of-5 standard. For this reason, it is important to keep at least one space between the barcode and the surrounding text to prevent overlapping.
- ❑ Interleaved 2 of 5 treats every two characters as one set. When there are an odd number of characters, EPSON ITF fonts automatically add a zero to the beginning of the character string.

Character type	Numbers (0 to 9)
Number of characters	No limit
Font size	When OCR-B is not used: 26 pt or more (up to 96 pt in Windows NT) Recommended sizes are 26 pt, 52 pt, 78 pt and 104 pt. When OCR-B is used: 36 pt or more (up to 96 pt in Windows NT) Recommended sizes are 36 pt, 72 pt, 108 pt and 144 pt.

The following codes are inserted automatically and need not be input by hand:

- Left/right quiet zone
- Start/Stop character
- Check digit
- The numeral "0" (added to the beginning of character strings as needed)

Print Sample

EPSON ITF	EPSON ITF CD
	
EPSON ITF Num	EPSON ITF CD Num
 0 1 2 3 4 5 6 7	 1 2 3 4 5 6 7 0

EPSON Codabar





- ❑ Four Codabar fonts are available, allowing you to enable and disable the automatic insertion of check digits and OCR-B.
- ❑ The height of the barcode is automatically adjusted to 15% or more of its total length, in conformance to the Codabar standard. For this reason, it is important to keep at least one space between the barcode and the surrounding text to prevent overlapping.
- ❑ When either a Start or a Stop character is input, Codabar fonts automatically insert the complimentary character.
- ❑ If neither a Start nor a Stop character is input, these characters are automatically input as the letter *A*.

Character type	Numbers (0 to 9) Symbols (- \$: / . +)
Number of characters	No limit
Font size	When OCR-B is not used: 26 pt or more (up to 96 pt in Windows NT) Recommended sizes are 26 pt, 52 pt, 78 pt and 104 pt. When OCR-B is used: 36 pt or more (up to 96 pt in Windows NT) Recommended sizes are 36 pt, 72 pt, 108 pt and 144 pt.

The following codes are inserted automatically and need not be input by hand:

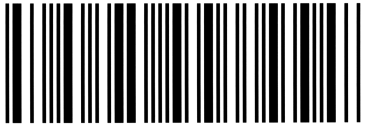
- ❑ Left/right quiet zone
- ❑ Start/Stop character (when not input)
- ❑ Check digit

Print Sample

EPSON Codabar	EPSON Codabar CD
	
EPSON Codabar Num	EPSON Codabar CD Num
 A 1 2 3 4 5 6 7 A	 A 1 2 3 4 5 6 7 4 A

Appendix C

Contacting Customer Support

For Users in the United Kingdom and the Republic of Ireland	150
For Users in Australia	151
For Users in Singapore	153
For Users in Hong Kong	154
For Users in Malaysia	155
For users in India	155
For Users in the Philippines	156

If your EPSON product is not operating properly and you cannot solve the problem using the troubleshooting information in your product documentation, contact customer support services for assistance. If customer support for your area is not listed below, contact the dealer where you purchased your product.

Customer support will be able to help you much more quickly if you give them the following information.

- Product serial number
(The serial number label is usually on the back of the product.)
- Product model
- Product software version
(Click About, Version Info, or similar button in the product software.)
- Brand and model of your computer
- Your computer operating system name and version
- Names and versions of the software applications you normally use with your product

For Users in the United Kingdom and the Republic of Ireland

If you purchased your product in the UK or the Republic of Ireland, EPSON (UK) LTD provides a range of customer services and technical support.

Support Via the World Wide Web

- ❑ For information on the latest EPSON products, software drivers, online user guides, and answers to frequently asked questions:

<http://www.epson.co.uk>

- ❑ To e-mail EPSON Technical Support:

<http://www.epson.co.uk/support/email/>

- ❑ For a full list of EPSON Customer and Warranty Support services:

<http://www.epson.co.uk/support/>

Support Via Telephone

Our Customer and Warranty Support teams can be contacted by calling 0870 163 7766 in the UK or 0044 0870 163 7766 from the Republic of Ireland. They can provide the following services:

- ❑ Technical information on installing, configuring, and operating your EPSON products
- ❑ Arranging for faulty EPSON products to be repaired within the warranty period

Pre-Sales Enquiry Desk

Our Enquiry Desk team can be contacted by calling 0800 220546 in the UK or 1 800 409132 from the Republic of Ireland, by faxing 01442 227271 in the UK or 0044 1442 227271 from the Republic of Ireland, and via e-mail at info@epson.co.uk. They can provide the following information:

- ❑ Pre-sales information and literature on new EPSON products (also available via our world wide web site at <http://www.epson.co.uk>)
- ❑ Where to purchase genuine EPSON consumables, accessories, and options

For Users in Australia

EPSON Australia wishes to provide you with a high level of customer service. In addition to your product documentation, we provide the following sources for obtaining information:

Your Dealer

Don't forget that your dealer can often help identify and resolve problems. The dealer should always be the first call for advise on problems, they can often solve problems quickly and easily as well as give advise on the next step to take.

Internet URL <http://www.epson.com.au>

Access the EPSON Australia World Wide Web pages. Worth taking your modem here for the occasional surf! The site provides a download area for drivers, EPSON contact points, new product information and technical support (e-mail).

EPSON Faxback service

EPSON Faxback service will fax you the latest specifications for most EPSON products offered in Australia. Phone (02) 9903 9075 and the system will guide you through a number of choices before faxing the information to your fax machine.

EPSON Helpdesk

EPSON Helpdesk is provided as a final backup to make sure our clients have access to advice. Operators on the Helpdesk can aid you in installing, configuring and operating your EPSON product. Our Pre-sales Helpdesk staff can provide literature on new EPSON products and advise where the nearest dealer or service agent is located. Many types of queries are answered here.

The Helpdesk numbers are:

Phone: 1300 361 054

Fax: (02) 9903 9189

We encourage you to have all the relevant information on hand when you ring. The more information you prepare, the faster we can help solve the problem. This information includes your EPSON product documentation, type of computer, operating system, application programs, and any information you feel is required.

For Users in Singapore

Sources of information, support, and services available from Epson Singapore are:

World Wide Web (www.epson.com.sg)

Information on product specifications, drivers for download, Frequently Asked Questions (FAQ), Sales Enquiries, and Technical Support via e-mail are available.

Epson HelpDesk (Phone: (065) 5863111)

Our HelpDesk team can help you with the following over the phone:

- Sales enquiries and product information
- Product usage questions or problem
- Enquiries on repair service and warranty

For Users in Hong Kong

To obtain technical support as well as other after-sales services, users are welcome to contact EPSON Hong Kong Limited.

Internet home page

EPSON Hong Kong has established a local home page in both Chinese and English on the Internet to provide users with the following information:

- Product information
- Answers to Frequently Asked Questions (FAQs)
- Latest versions of EPSON product drivers

Users can access our World Wide Web home page at:

<http://www.epson.com.hk>

Electronic bulletin board system

An electronic bulletin board system (BBS) is also available to obtain product information and the latest versions of product drivers. You can log on to the following number for the BBS service:

BBS: (852) 2827-4244

Technical Support Hotline

You can also contact our technical staff at the following telephone and fax numbers:

Phone: (852) 2585-4399

Fax: (852) 2827-4383

For Users in Malaysia

Contacts for information, support, and services are:

World Wide Web (www.epson.com.my)

Information on product specifications, drivers for download, Frequently Asked Questions (FAQ), and Email Enquiries are available.

Epson Trading Shah Alam Head Office

Phone: 03 5191366

Fax: 03 5191281

For users in India

Contacts for information, support, and services are:

World Wide Web (www.epson.co.in)

Information on product specifications, drivers for download, Frequently Asked Questions (FAQ), Products Enquiry, and Technical Query are available.

Epson India Bangalore Head Office:

Phone: 5321 266-70

Fax: 5581799/5321095

Help Desk Phone: -5321 625

For Users in the Philippines

To obtain technical support as well as other after sales services, users are welcome to contact the EPSON Philippines Representative Office at the telephone and fax numbers below:

Phone: (632) 813-6552

Fax: (632) 813-6545

BBS: (632) 814-0595

Glossary

ASCII

American Standard Code for Information Interchange. A standardized way of assigning codes to characters and control codes. This system is widely used by manufacturers of computers, printers, and software.

bitmap font

The dot-by-dot representation of a font. Bitmap fonts are displayed on computer screens and printed on dot matrix printers. See *outline font*.

buffer

See *memory*.

character set

A collection of letters, numbers, and symbols used in a particular language.

cpi (characters per inch)

A measure of the size of fixed-width text characters.

default

A value or setting that takes effect when the printer is turned on, reset, or initialized.

developer cartridge

A component of the printer that contains the toner that creates the printed image on paper.

dots per inch (dpi)

The number of dots per 25.4 mm (1 inch) is a measure of printer resolution. The higher the number of dots, the higher the resolution or print quality.

download

To transfer information from the computer to the printer.

dpi

See *dots per inch (dpi)*.

driver

The part of a software program that converts commands from the application program into commands used by the printer. Also known as the *printer driver*.

fixed-width font

A font whose characters are allotted the same amount of horizontal space, no matter the width of the character. Thus, the uppercase *M* receives the same amount of space as the letter *l*.

font

A set of characters and symbols that share a common typographic design and style.

halftone

A grayscale image that is composed of small dots. The dots can be close together to create black or more widely spaced to create gray or white areas in the image. Newspaper photographs are common examples of halftones.

initialization

The act of returning the printer to its defaults (fixed set of conditions).

interface

The connection between the printer and the computer. The parallel interface of this printer complies to the IEEE 1284 Parallel Interface standard that supports the Compatibility, Nibble, and ECP modes. The USB interface is a serial interface that complies to Microsoft Plug and Play (PnP) specification. With the use of a USB hub, multiple USB peripherals can be connected to the computer at the same time.

landscape

Printing that is oriented sideways on the page. This orientation gives you a page that is wider than it is high and is useful for printing spreadsheets.

memory

The part of the printer's electronic system that is used to store information. Some information is fixed and is used to control how the printer operates. Information that is sent to the printer from the computer (such as downloaded fonts) is stored in memory temporarily. See also *RAM* and *ROM*.

orientation

Refers to the direction in which characters are printed on a page. This direction is either portrait, like this page, or landscape, in which the page is rotated 90°.

outline font

A font whose outline is described mathematically, allowing it to be rendered (printed or drawn) smoothly at any size.

photoconductor unit

A component of the printer that contains a light-sensitive print drum which permanently fixes the toner onto paper.

pitch

A measure of the number of *characters per inch (cpi)* for fixed-width fonts.

portrait

Printing that is oriented upright on the page (as opposed to landscape, in which the printing is oriented sideways on the page). This is the standard orientation for printing letters or documents.

printer driver

See *driver*.

proportional font

A font whose characters have varying amounts of horizontal space depending on the width of the character. Thus, the uppercase *M* takes up more horizontal space than the lowercase *l*.

RAM

Random Access Memory (RAM) is where temporary information is stored.

reset

To refresh the printer's memory and erase the current print jobs.

resolution

A measure of the fineness and clarity of images produced by the printer or monitor. Printer resolution is measured in *dots per inch*. Monitor resolution is measured in pixels.

ROM

Read Only Memory (ROM) is where permanent information is stored.

status sheet

A report that lists the printer settings and other printer information.

TrueType

An outline font format that was developed jointly by Apple® Computer and Microsoft Corporation. TrueType fonts are outline fonts that can be easily resized for screen display or for printing.

Index

Numerics

- 500-Sheet Lower Paper Cassette Unit
 - feed jam, 97
 - installing, 62
 - removing, 63

C

- Cleaning
 - inside printer, 113
 - printer case, 116
- Consumable products
 - developer cartridge, 126
 - photoconductor unit, 127
 - replacing, 76
- Contacting EPSON, 149
- Customer support, 149

D

- Developer cartridge
 - replacing, 77
 - specifications, 126

E

- ECP mode, using, 51
- Envelopes, 29
- EPSON BarCode Fonts
 - about, 129
 - formatting, 136
 - inputting, 135
 - installing, 131
 - printing, 133
 - specifications, 136
 - system requirements, 130
- EPSON Status Monitor 3
 - about, 34
 - accessing, 36
 - monitoring preferences, 40
 - status alert window, 41
 - status details, 38
 - stopping monitoring, 42

F

- Face-up Tray
 - installing, 65
 - removing, 66
 - using, 66
- Fonts, EPSON BarCode Fonts, 129

I

- Interface
 - parallel interface, 124
 - USB connection, 52

L

- Labels, 30
- Letterhead, loading, 26

M

- Manual feed, 26
- Memory
 - maximum, 17
 - standard, 17
- Memory module
 - installing, 67
 - removing, 72
 - specifications, 67
- Monitoring preferences, 40
- MP tray, feed jam, 95

O

- Options
 - 500-Sheet Lower Paper Cassette Unit, 61
 - Face-up Tray, 61
 - interface cards, 61
 - memory module, 61
 - ROM module, 61

P

- Paper
 - printable area, 120
 - size, 120
 - specifications, 119
 - type, 119
 - weight, 119
- Paper handling
 - manual feed, 26
 - MP tray, 22
 - printing on special media, 28
- Paper jams
 - cleaning, 90
 - preventing, 89
- Paper source
 - 500-Sheet Lower Paper Cassette Unit, 21
 - MP tray, 21
- Parallel interface
 - ECP mode, 51
 - specifications, 124
- Photoconductor unit
 - replacing, 82
 - specifications, 127
- Printer
 - cleaning, 113
 - features, 16
 - problems, 89
 - specifications, 121
 - status, 38
 - transporting, 117
- Printer options, 61
- Problems
 - communication errors, 110
 - operational, 100
 - options, 108
 - paper jams, 90
 - printer driver, 109
 - printout, 101
 - print quality, 102

R

- Removing
 - memory module, 72
 - spilled toner, 115
- Replacing
 - developer cartridge, 77
 - photoconductor unit, 82

S

- Safety precautions, 9
- Specifications
 - 500-Sheet Lower Paper Cassette Unit, 125
 - developer cartridge, 126
 - electrical, 123
 - environmental, 122
 - Face-up Tray, 126
 - paper, 119
 - parallel interface, 124
 - photoconductor unit, 127
 - printer, 121
 - safety approvals, 122
 - USB interface, 52

T

- Technical support, 149
- Thick paper, 31
- Toner
 - removing spilled toner, 115
 - smudges, 104
- Transporting the printer, 117

U

- USB connection, specifications, 52

EPSON OVERSEAS MARKETING LOCATIONS

Epson America, Inc.

3840 Kilroy Airport Way
Long Beach, CA 90806-2469
Phone: (562) 981-3840
Fax: (562) 290-5220

EPSON UK LTD.

Campus 100, Maylands Avenue,
Hemel Hempstead, Herts,
HP2 7TJ, U.K.
Phone: (+44) 01442 261144
Fax: (+44) 01442 227227

EPSON DEUTSCHLAND GmbH

Zülpicher Straße 6,
40549 Düsseldorf Germany
Phone: (0211) 56030
Fax: (0211) 5047787

EPSON FRANCE S.A.

68 bis, rue Marjolin
92300, Levallois-Perret, France
Phone: 33.1.40.87.3737
Telex: 610657

EPSON AUSTRALIA PTY. LTD.

70 GIBBES STREET,
CHATSWOOD 2067 NSW.
Phone: 2-9903-9000
Fax: 2-9903-9177

EPSON SINGAPORE PTE. LTD.

No. 1 Temasek Avenue #36-00
Millenia Tower, Singapore 039192
Phone: (065) 33 77 911
Fax: (065) 33 41 185

EPSON HONG KONG LTD.

Rooms 4706-10, 47/F,
China Resources Bldg.,
26 Harbour Road, Wanchai, Hong Kong
Phone: 2585-4300
Fax: 2827-7083

EPSON TAIWAN TECHNOLOGY & TRADING LTD.

10F, No. 287 Nanking E. Road, Sec. 3,
Taipei, Taiwan, R.O.C.
Phone: (02) 717-7360
Fax: (02) 712-9164

EPSON ITALIA S.p.A.

V.le F.lli Casiraghi 427
20099 Sesto S.Giovanni
MI, Italy
Phone: +3902262331
Fax: +39022440750

EPSON IBERICA S.A.

Av. de Roma, 18-26
08290 Cerdanyola del Valles
Barcelona, Spain
Phone: 582. 15.00
Fax: 582. 15.55

SEIKO EPSON CORPORATION (Hirooka Office)

80 Harashinden, Hirooka
Shiojiri-shi, Nagano-ken
399-0785 Japan

EPSON PORTUGAL, S.A.

R. do Progresso, 471, 1º Perafita
4460 Matosinhos, Portugal
Phone: (02) 996 14 02
Fax: (02) 996 14 11

EPSON