



EPSON **AcuLaser C9200 Series**

# **User's Guide**

---

NPD3657-00 EN

---

## Copyright and Trademarks

No part of this publication may be reproduced, stored in a retrieval system, or transmitted in any form or by any means, mechanical, photocopying, recording, or otherwise, without the prior written permission of Seiko Epson Corporation. No patent liability is assumed with respect to the use of the information contained herein. Neither is any liability assumed for damages resulting from the use of the information contained herein.

Neither Seiko Epson Corporation nor its affiliates shall be liable to the purchaser of this product or third parties for damages, losses, costs, or expenses incurred by purchaser or third parties as a result of: accident, misuse, or abuse of this product or unauthorized modifications, repairs, or alterations to this product, or (excluding the U.S.) failure to strictly comply with Seiko Epson Corporation's operating and maintenance instructions.

Seiko Epson Corporation and its affiliates shall not be liable against any damages or problems arising from the use of any options or any consumable products other than those designated as Original Epson Products or Epson Approved Products by Seiko Epson Corporation.

Features Zoran Corporation Integrated Print System (IPS) for print language emulation.



NEST Office Kit Copyright © 1996, Novell, Inc. All rights reserved.

A part of the ICC Profile contained within this product was created by Gretag Macbeth ProfileMaker. Gretag Macbeth is the registered trademark of Gretag Macbeth Holding AG Logo. ProfileMaker is a trademark of LOGO GmbH.

IBM and PS/2 are registered trademarks of International Business Machines Corporation.

Microsoft®, Windows®, and Windows Vista® are registered trademarks of Microsoft Corporation.

Apple®, Macintosh®, Mac®, Mac OS®, AppleTalk®, and Bonjour® are registered trademarks of Apple, Inc. Apple Chancery, Chicago, Geneva, Hoefler Text, Monaco and New York are trademarks or registered trademarks of Apple, Inc.

EPSON and EPSON ESC/P are registered trademarks and EPSON AcuLaser and EPSON ESC/P 2 are trademarks of Seiko Epson Corporation.

Monotype is a trademark of Monotype Imaging, Inc. registered in the United States Patent and Trademark Office and may be registered in certain jurisdictions.

The UFST® (Universal Font Scaling Technology™) product is Monotype Imaging's scalable font rendering subsystem for printer devices.

MicroType® font compression technology from Monotype Imaging works with the UFST® font rendering subsystem to significantly reduce font file sizes.

Monotype Imaging's MicroType® font format is a MicroType-compressed font format.

CG Omega, CG Times, Garamond Antiqua, Garamond Halbfett, Garamond Kursiv, Garamond Halbfett Kursiv are trademarks of Monotype Imaging, Inc. and may be registered in certain jurisdictions.

Albertus, Arial, Coronet, Gillsans, Times New Roman and Joanna are trademarks of The Monotype Corporation registered in the United States Patent and Trademark Office and may be registered in certain jurisdictions.

ITC Avant Garde Gothic, ITC Bookman, ITC Lubalin Graph, ITC Mona Lisa Recut, ITC Symbol, ITC Zapf-Chancery, and ITC ZapfDingbats are trademarks of International Typeface Corporation registered in the United States Patent and Trademark Office and may be registered in certain jurisdictions.

Clarendon, Helvetica, New Century Schoolbook, Optima, Palatino, Stempel Garamond, Times and Univers are registered trademarks of Heidelberger Druckmaschinen AG, which may be registered in certain jurisdictions, exclusively licensed through Linotype Library GmbH, a wholly owned subsidiary of Heidelberger Druckmaschinen AG.

Wingdings is a registered trademark of Microsoft Corporation in the United States and other countries.

Marigold is trademark of Arthur Baker and may be registered in some jurisdictions.

Antique Olive is a registered trademark of Marcel Olive and may be registered in certain jurisdictions.

Carta and Tekton are registered trademarks of Adobe Systems Incorporated.

Marigold and Oxford are trademarks of AlphaOmega Typography.

Coronet is a registered trademark of Ludlow Type Foundry.

Eurostile is a trademark of Nebiolo.

HP and HP LaserJet are registered trademarks of the Hewlett-Packard Company.

PCL is the registered trademark of Hewlett-Packard Company.

Adobe, the Adobe logo and PostScript3 are trademarks of Adobe Systems Incorporated, which may be registered in certain jurisdictions.

CompactFlash is a trademark of SanDisk Corporation, registered in the United States and other countries.

*General Notice: Other product names used herein are for identification purposes only and may be trademarks of their respective owners. Epson disclaims any and all rights in those marks.*

Copyright © 2008 Seiko Epson Corporation. All rights reserved.

---

## ***Operating System Versions***

In this manual, the following abbreviations are used.

**Windows refers to Windows Vista, XP, Vista x64, XP x64, 2000, Server 2003, and Server 2003 x64.**

- ❑ Windows Vista refers to Windows Vista Ultimate Edition, Windows Vista Home Premium Edition, Windows Vista Home Basic Edition, Windows Vista Enterprise Edition and Windows Vista Business Edition.
- ❑ Windows Vista x64 refers to Windows Vista Ultimate x64 Edition, Windows Vista Home Premium x64 Edition, Windows Vista Home Basic x64 Edition, Windows Vista Enterprise x64 Edition and Windows Vista Business x64 Edition.
- ❑ Windows XP refers to Windows XP Home Edition and Windows XP Professional.
- ❑ Windows XP x64 refers to Windows XP Professional x64 Edition.
- ❑ Windows 2000 refers to Windows 2000 Professional.
- ❑ Windows Server 2003 refers to Windows Server 2003 Standard Edition and Windows Server 2003 Enterprise Edition.
- ❑ Windows Server 2003 x64 refers to Windows Server 2003 x64 Standard Edition and Windows Server 2003 x64 Enterprise Edition.

**Macintosh refers to Mac OS X.**

- ❑ Mac OS X refers to Mac OS X 10.3.9 or later.

---

## Contents

### **Safety Instructions**

---

Safety. . . . .	14
Warnings, Cautions, and Notes. . . . .	14
Safety precautions. . . . .	14
Important Safety Instructions. . . . .	16
Safety Information. . . . .	18
Power On/Off Cautions. . . . .	19

### **Chapter 1 Getting to Know Your Printer**

---

Where to Find Information. . . . .	21
Printer Parts. . . . .	22
Front view. . . . .	22
Rear view. . . . .	23
Inside the printer. . . . .	24
Control panel. . . . .	25
Options and Consumable Products. . . . .	26
Options. . . . .	26
Consumable products. . . . .	27

### **Chapter 2 Printing Tasks**

---

Loading Paper into Your Printer. . . . .	28
MP tray. . . . .	28
Standard lower paper cassette. . . . .	30
Optional paper cassette unit. . . . .	35
Output tray. . . . .	39
Selecting and Using Print Media. . . . .	40
Labels. . . . .	40
Envelopes. . . . .	41
Thick paper. . . . .	42
EPSON Color Laser Coated Paper. . . . .	43
EPSON Color Laser Transparencies. . . . .	43
Custom paper size. . . . .	43

Cancelling a Print Job. . . . .	45
From the printer. . . . .	45
From the computer. . . . .	45
Setting the Print Quality. . . . .	46
Using the Automatic setting. . . . .	46
Using the Advanced setting. . . . .	48
Customizing print settings. . . . .	50
Toner Save mode. . . . .	52
Monochrome Model Compatibility mode. . . . .	53
Setting the Advanced Layout. . . . .	53
Duplex printing (with the Duplex Unit). . . . .	53
Modifying the print layout. . . . .	56
Resizing printouts. . . . .	57
Printing watermarks. . . . .	59
Printing headers and footers. . . . .	65
Printing with an overlay. . . . .	67
Printing with an overlay (with the storage). . . . .	70
Printing the copy-protected document. . . . .	72
Printing Web Pages to Fit Your Paper Size. . . . .	75
Using the Reserve Job Function. . . . .	76
Sending the print job. . . . .	77

### **Chapter 3 Using the Control Panel**

---

Using the Control Panel Menus. . . . .	79
When to make control panel settings. . . . .	79
How to access the control panel menus. . . . .	79
How to register menus as bookmarks. . . . .	80
Control Panel Menus. . . . .	81
Information Menu. . . . .	81
System Information Menu. . . . .	84
Tray Menu. . . . .	84
Emulation Menu. . . . .	85
Printing Menu. . . . .	85
Setup Menu. . . . .	87
Reset Menu. . . . .	91
Quick Print Job Menu. . . . .	92
Confidential Job Menu. . . . .	92
Clock Menu. . . . .	92

Parallel Menu. . . . .	92
USB Menu. . . . .	94
Network Menu. . . . .	95
AUX Menu. . . . .	95
PCL Menu. . . . .	95
PS3 Menu. . . . .	97
ESCP2 Menu. . . . .	98
FX Menu. . . . .	100
I239X Menu. . . . .	102
Password Config Menu. . . . .	105
Support Menu. . . . .	105
Bookmark Menu. . . . .	106
Status and Error Messages. . . . .	106
Printing and Deleting Reserve Job Data. . . . .	119
Using the Quick Print Job Menu. . . . .	120
Using the Confidential Job Menu. . . . .	120
Printing a Configuration Status Sheet. . . . .	121
Canceling Printing. . . . .	122
Using the Cancel Job button. . . . .	122
Using the Reset menu. . . . .	122

#### **Chapter 4 *Installing Options***

---

Optional Printer Stand and Paper Cassette Unit. . . . .	124
Handling precautions. . . . .	124
Installing the optional printer stand. . . . .	125
Installing the optional paper cassette unit. . . . .	128
Removing the optional paper cassette unit. . . . .	136
Duplex Unit. . . . .	137
Installing the Duplex Unit. . . . .	137
Removing the Duplex Unit. . . . .	144
Memory Module. . . . .	150
Installing a memory module. . . . .	150
Removing a memory module. . . . .	153
Interface Card. . . . .	154
Installing an interface card. . . . .	154
Removing an interface card. . . . .	156
CompactFlash Memory. . . . .	156
Installing a CompactFlash memory. . . . .	156

Removing a CompactFlash memory. . . . .	158
---	-----

## **Chapter 5 Replacing Consumable Products**

---

Precautions During Replacement. . . . .	160
Replacement Messages. . . . .	160
Toner Cartridge. . . . .	161
Photoconductor Unit. . . . .	165
Waste Toner Collector and Filter. . . . .	170

## **Chapter 6 Cleaning and Transporting the Printer**

---

Cleaning the Printer. . . . .	174
Cleaning the pickup roller. . . . .	174
Cleaning the exposure window. . . . .	176
Transporting the Printer. . . . .	179
Finding a place for the printer. . . . .	179
For long distances. . . . .	180
For short distances. . . . .	181

## **Chapter 7 Troubleshooting**

---

Clearing Jammed Paper. . . . .	183
Precautions for clearing jammed paper. . . . .	183
Paper Jam A (Cover A). . . . .	184
Paper Jam B H (Cover B or H). . . . .	185
Paper Jam D (Duplex Unit cover). . . . .	189
Paper Jam G (Paper path G). . . . .	192
Paper Jam E2, Paper Jam E3, Paper Jam E4 (Cover E2, Cover E3, Cover E4). . . . .	193
Printing a Configuration Status Sheet. . . . .	195
Operational Problems. . . . .	195
The Ready light does not turn on. . . . .	195
The printer does not print (Ready light off). . . . .	196
The Ready light is on but nothing prints. . . . .	196
The optional product is not available. . . . .	196
The remaining service life of the consumables is not updated (For Windows users only). . . . .	197
Printout Problems. . . . .	197
The font cannot be printed. . . . .	197



Printout is garbled. . . . .	198
The printout position is not correct. . . . .	198
Graphics do not print correctly. . . . .	198
Transparencies are output blank from the MP tray. . . . .	199
Color Printing Problems. . . . .	199
Cannot print in color. . . . .	199
The printout color differs when printed from different printers. . . . .	199
The color looks different from what you see on the computer screen. . . . .	200
Print Quality Problems. . . . .	200
The background is dark or dirty. . . . .	200
White dots appear in the printout. . . . .	200
Print quality or tone is uneven. . . . .	200
Half-tone images print unevenly. . . . .	201
Toner smudges. . . . .	202
Areas are missing in the printed image. . . . .	202
Completely blank pages are output. . . . .	203
The printed image is light or faint. . . . .	203
The non-printed side of the page is dirty. . . . .	204
Print quality decreased. . . . .	205
Memory Problems. . . . .	205
Insufficient memory for current task. . . . .	205
Insufficient memory to print all copies. . . . .	205
Paper Handling Problems. . . . .	206
Paper does not feed properly. . . . .	206
Problems Using Options. . . . .	206
The message Invalid AUX I/F Card appears on the LCD panel. . . . .	206
Paper does not feed from the optional paper cassette. . . . .	207
Feed jam when using the optional paper cassette. . . . .	207
An installed option cannot be used. . . . .	207
Correcting USB Problems. . . . .	208
USB connections. . . . .	208
Windows operating system. . . . .	208
Printer software installation. . . . .	208
Network Connection Problems. . . . .	209
Cannot install software or drivers. . . . .	209
Cannot access the shared printer. . . . .	209
Status and Error Messages. . . . .	210
Canceling Printing. . . . .	210
Printing in the PostScript 3 Mode Problems. . . . .	210
The printer does not print correctly in the PostScript mode. . . . .	211

The printer does not print. . . . . 211

The printer driver or printer that you need to use does not appear in the Print & Fax (for Mac OS X 10.5) or Printer Setup Utility (Mac OS X 10.4 or below). . . . . 211

The font on the printout is different from that on the screen. . . . . 212

The printer fonts cannot be installed. . . . . 212

The edges of texts and/or images are not smooth. . . . . 212

The printer does not print normally via the USB interface. . . . . 212

The printer does not print normally via the network interface. . . . . 213

An undefined error occurs (Macintosh only). . . . . 213

Printing in the PCL5/PCL6 Mode Problems. . . . . 214

    The printer does not print. . . . . 214

    The printer does not print correctly in the PCL mode. . . . . 214

    The font on the printout is different from that on the screen. . . . . 214

    The edges of texts and/or images are not smooth. . . . . 214

    The printer does not print on transparencies. . . . . 215

    The printer does not print on the specified paper type. . . . . 215

    The Custom button is grayed out and the custom paper size cannot be created (Windows Vista/Vista x64 only). . . . . 215

    The items in the Tray tab/Printer tab are grayed out and these items cannot be changed (Windows Vista/Vista x64 only). . . . . 215

**Chapter 8 About the Printer Software for Windows**

Using the Printer Driver . . . . . 216

    Accessing the printer driver. . . . . 216

    Printing a configuration status sheet. . . . . 217

    Making Extended Settings. . . . . 217

    Making Optional Settings. . . . . 217

    Displaying consumable information. . . . . 217

    Ordering Consumables. . . . . 218

Using EPSON Status Monitor. . . . . 218

    Installing EPSON Status Monitor. . . . . 218

    Accessing EPSON Status Monitor. . . . . 220

    Detailed Status. . . . . 221

    Replacement Parts Information. . . . . 222

    Job Information. . . . . 223

    Notice Settings. . . . . 225

    Order Online. . . . . 227

Uninstalling the Printer Software. . . . . 227

**Chapter 9 About the Printer Software for Macintosh**

---

Using the Printer Driver. . . . .	230
Accessing the printer driver. . . . .	230
Printing a configuration status sheet. . . . .	230
Changing the Printer Settings. . . . .	231
Making Extended Settings. . . . .	231
Using EPSON Status Monitor. . . . .	231
Accessing EPSON Status Monitor. . . . .	231
Detailed Status. . . . .	233
Replacement Parts Information. . . . .	234
Job Information . . . . .	235
Notice Settings. . . . .	236
Uninstalling the Printer Software. . . . .	237
For Mac OS X users. . . . .	237

**Chapter 10 About the PostScript Printer Driver**

---

System Requirements. . . . .	239
Printer hardware requirements. . . . .	239
Computer system requirements. . . . .	239
Using the PostScript Printer Driver with Windows. . . . .	240
Installing the PostScript printer driver for the parallel interface. . . . .	240
Installing the PostScript printer driver for the USB interface. . . . .	241
Installing the PostScript printer driver for the network interface. . . . .	242
Accessing the PostScript printer driver. . . . .	243
Using AppleTalk under Windows 2000. . . . .	243
Using the PostScript Printer Driver with Macintosh. . . . .	244
Installing the PostScript printer driver. . . . .	244
Selecting the printer. . . . .	244
Accessing the PostScript printer driver. . . . .	246

**Chapter 11 About the PCL5/PCL6 Printer Driver**

---

System Requirements. . . . .	248
Printer hardware requirements. . . . .	248
Computer system requirements. . . . .	248
Using the PCL5/PCL6 Printer Driver. . . . .	249
Installing the PCL5/PCL6 printer driver. . . . .	250

Accessing the PCL5/PCL6 printer driver. . . . .	250
---	-----

## **Appendix A Technical Specifications**

---

Paper. . . . .	252
Available paper types. . . . .	252
Paper that should not be used. . . . .	252
Printable area. . . . .	253
Printer. . . . .	254
General. . . . .	254
Environmental. . . . .	255
Mechanical. . . . .	255
Electrical. . . . .	256
Standard and approvals. . . . .	256
Interfaces. . . . .	256
Parallel Interface. . . . .	256
USB interface. . . . .	257
Ethernet interface. . . . .	257
Options and Consumable Products. . . . .	257
Optional paper cassette unit. . . . .	257
Duplex Unit. . . . .	258
Printer Stand. . . . .	258
Memory modules. . . . .	259
CompactFlash memory. . . . .	259
Toner Cartridge. . . . .	259
Photoconductor Unit. . . . .	259
Waste Toner Collector. . . . .	260

## **Appendix B Customer Support**

---

Contacting Customer Support. . . . .	261
Before Contacting Epson. . . . .	261
Help for Users in Australia. . . . .	261
Help for Users in Singapore. . . . .	262
Help for Users in Thailand. . . . .	263
Help for Users in Vietnam. . . . .	263
Help for Users in Indonesia. . . . .	263
Help for Users in Hong Kong. . . . .	265

Help for Users in Malaysia. . . . . 265  
Help for Users in India. . . . . 266  
Help for Users in the Philippines. . . . . 267

***Index***

---

---

## Safety Instructions

---

### Safety

#### Warnings, Cautions, and Notes

**Warnings**

*must be followed carefully to avoid bodily injury.*

**Cautions**

*must be observed to avoid damage to your equipment.*

**Notes**

*contain important information and useful tips on the operation of your printer.*

#### Safety precautions

Be sure to follow the precautions carefully to ensure safe and efficient operation:

- ❑ Because the printer weighs approximately 60 kg (132 lb) with consumable products installed, one person should not lift or carry it. Two people should carry the printer, lifting it by the correct positions as shown below.

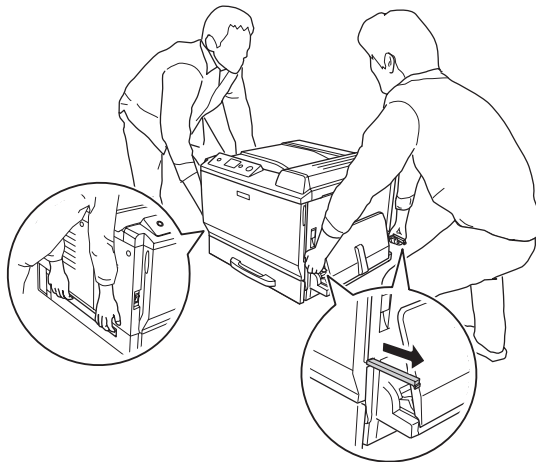

- ❑ Be careful not to touch the fuser, which is marked **CAUTION HIGH TEMPERATURE**, or the surrounding areas. If the printer has been in use, the fuser and the surrounding areas may be very hot. If you must touch one of these areas, wait 30 minutes to allow the heat to subside before doing so.

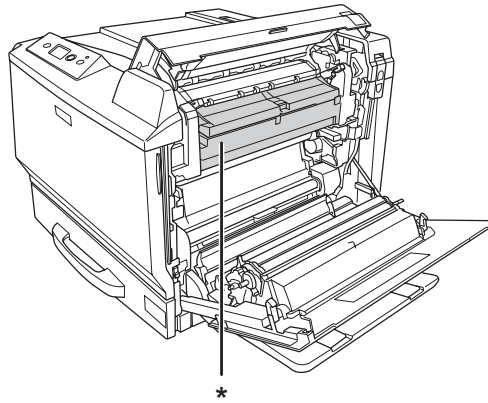

**\*CAUTION HIGH TEMPERATURE**

- ❑ Do not insert your hand deep into the fuser unit as some components are sharp and may cause injury.
- ❑ Avoid touching the components inside the printer unless instructed to do so in this guide.
- ❑ Never force the printer's components into place. Although the printer is designed to be sturdy, rough handling can damage it.
- ❑ When handling a toner cartridge, always place it on a clean, smooth surface.
- ❑ Do not attempt to modify a toner cartridge or take it apart.
- ❑ Do not touch the toner. Keep the toner away from your eyes.
- ❑ Do not dispose of used toner cartridge or photoconductor unit in fire, as they can explode and cause injury. Dispose of them according to local regulations.
- ❑ If toner is spilled, use a broom and dustpan or a damp cloth with soap and water to clean it up. Because the fine particles can cause a fire or explosion if they come into contact with a spark, do not use a vacuum cleaner.
- ❑ Wait at least one hour before using a toner cartridge after moving it from a cool to a warm environment to prevent damage from condensation.

- ❑ When removing the photoconductor unit, do not expose it to sunlight at all and avoid exposing it to room light for more than five minutes. The photoconductor unit contains a light-sensitive drum. Exposure to light can damage the drum, causing dark or light areas to appear on the printed page and reducing the service life of the drum. If you need to keep the photoconductor unit out of the printer for long periods, cover it with an opaque cloth.
- ❑ Be careful not to scratch the surface of the drum. When you remove the photoconductor unit from the printer, always place it on a clean, smooth surface. Avoid touching the drum, since oil from your skin can permanently damage its surface and affect print quality.
- ❑ To get the best print quality, do not store the toner cartridge or photoconductor unit in an area subject to direct sunlight, dust, salty air, or corrosive gases (such as ammonia). Avoid locations subject to extreme or rapid changes in temperature or humidity.
- ❑ Be sure to keep consumable components out of the reach of children.
- ❑ Do not leave jammed paper inside the printer. This can cause the printer to overheat.
- ❑ Avoid sharing outlets with other appliances.

## ***Important Safety Instructions***

Read all of the following instructions before operating your printer:

### ***When choosing a place and power source for the printer***

- ❑ Place the printer near an electrical outlet where you can easily plug in and unplug the power cord.
- ❑ Do not place the printer on an unstable surface.
- ❑ Do not put your printer where the cord will be stepped on.
- ❑ Slots and openings in the cabinet and the back or bottom are provided for ventilation. Do not block or cover them. Do not put the printer on a bed, sofa, rug, or other similar surface or in a built-in installation unless proper ventilation is provided.
- ❑ All interface connectors for this printer are Non-LPS (non-limited power source).
- ❑ Connect all equipment to properly grounded power outlets. Avoid using outlets on the same circuit as photocopiers or air control systems that regularly switch on and off.
- ❑ Connect your printer to an electrical outlet that meets the power requirements of this printer. Your printer's power requirements are indicated on a label attached to the printer. If you are not sure of the power supply specifications in your area, contact your local power company or consult your dealer.



- ❑ If you are unable to insert the AC plug into the electrical outlet, contact an electrician.
- ❑ Use the type of power source indicated on the label. If you are not sure of the type of power available, consult your dealer or local power company.
- ❑ When connecting this product to a computer or other device with a cable, ensure the correct orientation of the connectors. Each connector has only one correct orientation. Inserting a connector in the wrong orientation may damage both devices connected by the cable.
- ❑ If you use an extension cord, make sure that the total of the ampere ratings on the products plugged into the extension cord does not exceed the extension cord ampere rating.
- ❑ Unplug this printer from the wall outlet and refer servicing to a qualified service representative under the following conditions:
  - A. When the power cord or plug is damaged or frayed.
  - B. If liquid has been spilled into it.
  - C. If it has been exposed to rain or water.
  - D. If it does not operate normally when the operating instructions are followed. Adjust only those controls that are covered by the operating instructions since improper adjustment of other controls may result in damage and will often require extensive work by a qualified technician to restore the product to normal operation.
  - E. If it has been dropped or the cabinet has been damaged.
  - F. If it exhibits a distinct change in performance, indicating a need for service.

### ***When using the printer***

- ❑ The printer weighs about 60 kg (132 lb). One person should not attempt to lift or carry the printer. Two people should carry it.
- ❑ Follow all warnings and instructions marked on the printer.
- ❑ Unplug this printer from the wall outlet before cleaning.
- ❑ Use a well-wrung cloth for cleaning and do not use liquid or aerosol cleaners.
- ❑ Do not use printer in a damp environment.
- ❑ Never push objects of any kind through cabinet slots as they may touch dangerous voltage points or short out parts that could result in a risk of fire or electric shock.

- ❑ Never spill liquid of any kind on the printer.
- ❑ Except as specifically explained in the printer's documentation, do not attempt to service this product yourself.
- ❑ Adjust only those controls that are covered by the operating instructions. Improper adjustment of other controls may result in damage and may require repair by a qualified service representative.

## Safety Information

### Power cord



#### Caution:

- ❑ *Be sure the AC power cord meets the relevant local safety standards. Use only the power cord that comes with this product. Use of the another cord may result in fire or electric shock. This product's power cord is for use with this product only. Use with other equipment may result in fire or electric shock.*
- ❑ *If damage occurs to the plug, replace the cord set or consult a qualified electrician. If there are fuses in the plug, make sure you replace them with fuses of the correct size and rating.*

### Laser safety labels



#### Warning:

*The performance of procedures and adjustments other than those specified in the printer's documentation may result in hazardous radiation exposure. Your printer is a Class 1 laser product as defined in the IEC60825 specifications. The label shown is attached to the back of the printer in countries where required.*



### ***Internal laser radiation***

There is a Class III b Laser Diode Assembly that has an invisible laser beam inside the printer head unit. The printer head unit is NOT A SERVICE ITEM, therefore, the printer head unit should not be opened under any circumstances. An additional laser warning label is affixed to the inside of the printer.

### ***Ozone safety***

#### *Ozone emission*

Ozone gas is generated by laser printers as a by-product of the printing process. Ozone is produced only when the printer is printing.

#### *Ozone exposure limit*

The Epson laser printer generates less than 3 mg/h of continuous printing.

#### *Minimize the risk*

To minimize the risk of exposure to ozone, you should avoid the following conditions:

- Use of multiple laser printers in a confined area
- Operation in conditions of extremely low humidity
- Poor room ventilation
- Long, continuous printing together with any of the above

#### *Printer location*

The printer should be located so that the exhaust gases and heat generated are:

- Not blown directly into the user's face
- Vented directly out of the building whenever possible

### ***Power On/Off Cautions***

Do not turn off the printer:

- After turning on the printer, wait until **Ready** appears on the LCD panel.

- While the **Ready** light is flashing.
- While the **Data** light is on or flashing.
- While printing.

## Chapter 1

# Getting to Know Your Printer

---

## Where to Find Information

---

### Setup Guide

Provides you with information on assembling the printer and installing the printer software.

### User's Guide (this manual)

Provides you with detailed information on the printer's functions, optional products, maintenance, troubleshooting, and technical specifications.

### Network Guide

Provides network administrators with information on both the printer driver and network settings. You need to install this guide from the Network Utilities CD-ROM to your computer's hard disk before referring it.

\* The Network Utilities CD-ROM may not be included with the product in some countries or regions. In this case, you can install the Network Guide from the Software CD-ROM.

### Paper Jam Guide

Provides you with solutions for paper jam problems about your printer you may need to refer to on a regular basis. We recommend printing this guide and keeping it near the printer.

### Font Guide

Provides you with information on fonts used on the printer. You need to copy this guide, or you can open it directly from following directory on the software CD-ROM.

For Windows: /COMMON/MANUAL/ENG/FNTG

For Macintosh: MANUAL:ENG:FNTG

### Online Help for printer software

Click **Help** for detailed information and instructions on the printer software that controls your printer. Online help is automatically installed when you install the printer software.

## Printer Parts

### Front view

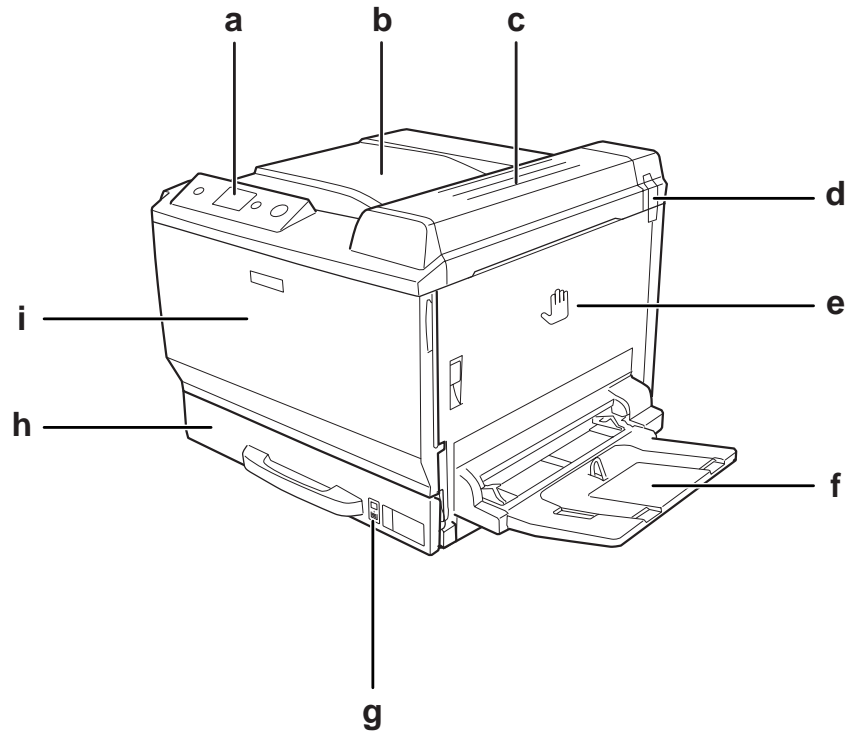

- a. control panel
- b. output tray
- c. cover B
- d. odor filter
- e. cover A
- f. MP tray
- g. paper indicator
- h. standard lower paper cassette
- i. cover F

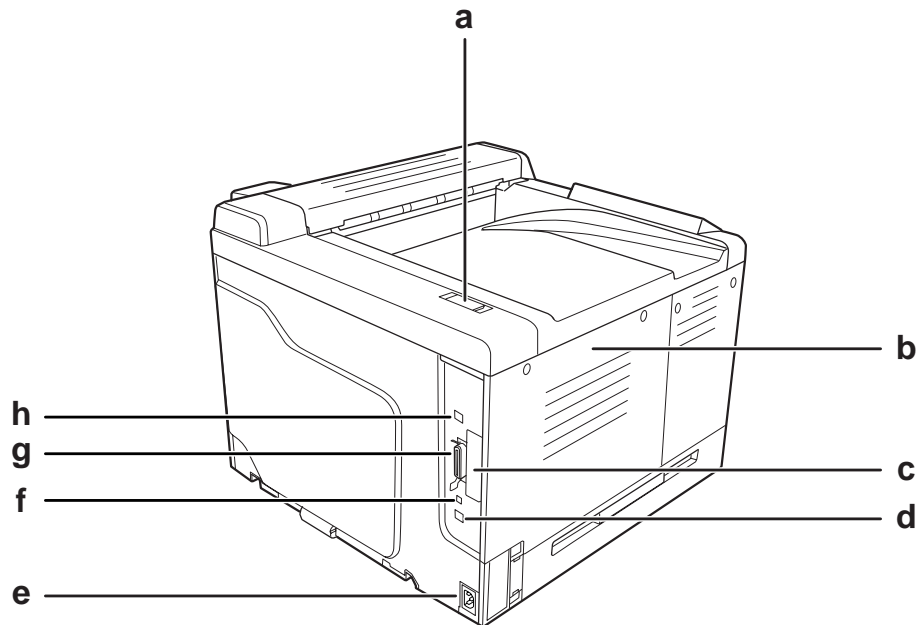
**Rear view**

- a. exhaust filter
- b. left side cover
- c. Type-B interface card slot cover
- d. Ethernet interface connector
- e. AC inlet
- f. service connector (for service use only)
- g. parallel interface connector
- h. USB interface connector

## Inside the printer

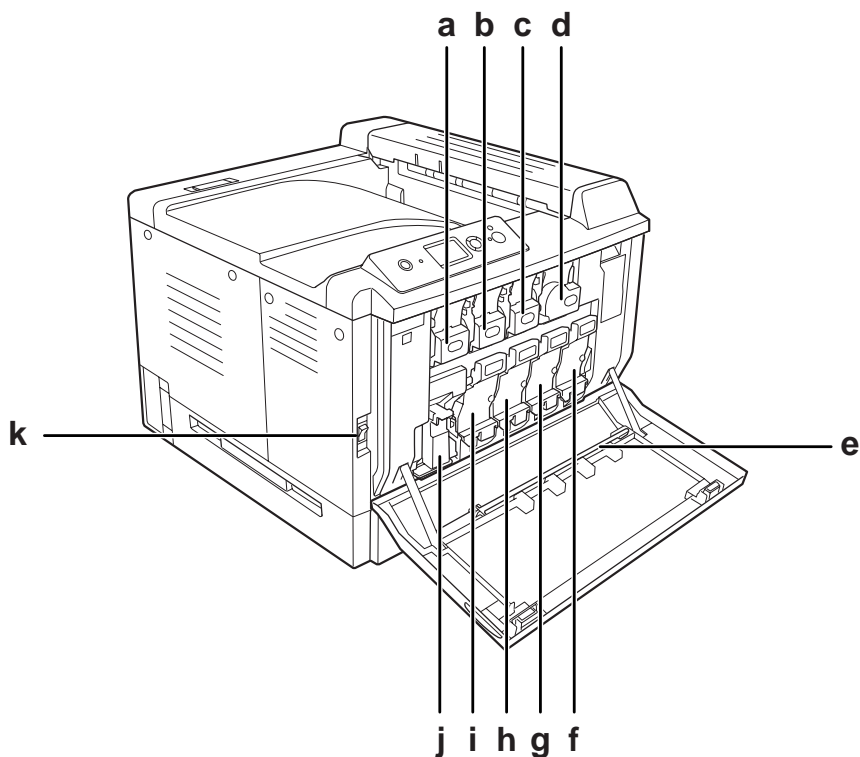

- a. toner cartridge (Yellow)
- b. toner cartridge (Magenta)
- c. toner cartridge (Cyan)
- d. toner cartridge (Black)
- e. exposure window cleaning bar
- f. photoconductor unit (Black)
- g. photoconductor unit (Cyan)
- h. photoconductor unit (Magenta)
- i. photoconductor unit (Yellow)
- j. waste toner collector
- k. power switch





- |    |                             |   |
|----|-----------------------------|---|
| b. | <b>OK</b> button            | Use these buttons to access the control panel menus, where you can make printer settings and check the status of consumable products. For instructions on how to use these buttons, see “Using the Control Panel Menus” on page 79. |
| c. | <b>Back</b> button          |   |
| d. | <b>Up</b> button            |   |
| e. | <b>Enter</b> button         |   |
| f. | <b>Down</b> button          |   |
| g. | <b>Ready</b> light (Green)  |   |
| h. | <b>Error</b> light (Orange) | On or flashes when an error has occurred.   |
| i. | <b>Start/Stop</b> button    | When the printer is printing, pressing this button stops the printing.<br>When the error light is flashing, pressing this button clears the error and switches the printer to ready status.   |
| j. | <b>Data</b> light (Green)   | On when print data is stored in the print buffer (the section of printer memory reserved for receiving data) but not yet printed.<br>Flashes when the printer is processing data.<br>Off when no data remains in the print buffer.  |
| k. | <b>Cancel Job</b> button    | Press once to cancel the current print job. Press and hold for more than two seconds to delete all jobs from the printer memory.  |

---

## Options and Consumable Products

### Options

You can add to your printer's capabilities by installing any of the following options.

- Printer Stand (C12C847202)**  
This option is installed to fix the printer and enables the printer to move easily with its casters.
- 500-Sheet Paper Cassette Unit (C12C802502)**  
This unit increases paper feeding capacity up to 500 sheets of paper. You can install up to three units.
- Duplex Unit (C12C802512)**  
This unit allows for automatic printing on both sides of paper.

CompactFlash Memory

This option enables you to store overlay forms, use Reserve Job function, and improve the collate printing environment. By using the Reserve Job function, you can store print jobs in the printer's CompactFlash memory and print them later directly from the printer's control panel. By using the collate printing function, you can print larger and more complex print jobs.

Memory Module

This option expands the printer's memory by allowing you to print complex and graphics-intensive documents. The printer's RAM can be increased up to 768 MB by adding an additional 512 MB RAM DIMM.

**Note:**

*Make sure that the DIMM you purchase is compatible with EPSON products. For details, contact the store where you purchased this printer or an EPSON qualified service representative.*

## Consumable products

The life of the following consumable products is monitored by the printer. The printer lets you know when replacements are needed.

Product name	Product code
Toner Cartridge (Yellow)	0474
Toner Cartridge (Magenta)	0475
Toner Cartridge (Cyan)	0476
Toner Cartridge (Black)	0477
Photoconductor Unit (Yellow)	1175
Photoconductor Unit (Magenta)	1176
Photoconductor Unit (Cyan)	1177
Photoconductor Unit (Black)	1178
Waste Toner Collector	0478

## Chapter 2

### Printing Tasks

#### Loading Paper into Your Printer

This section describes how to load paper. If you use special media such as transparencies or envelopes, see also “Selecting and Using Print Media” on page 40. For specifications or details about the paper types and sizes, see “Paper” on page 252.

#### MP tray

The MP tray (Multi-purpose tray) is the paper source that is available for various types of paper, such as labels, envelopes, thick paper, EPSON Color Laser Coated Paper, and Epson Color Laser Transparencies.

**Note:**

To load envelopes, see “Envelopes” on page 41.

1. Open the MP tray.

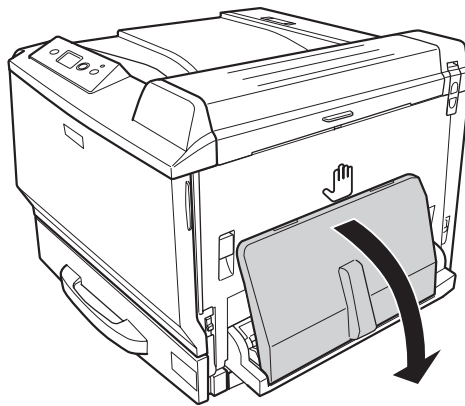

2. Slide the paper guides outward.

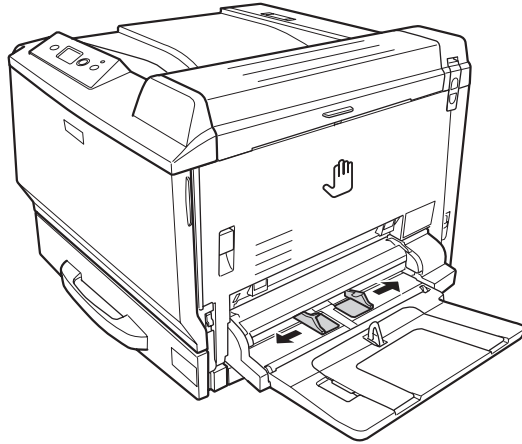

**Note:**

*When the loading paper size is bigger than A4, open the extension tray on the MP tray to accommodate the paper.*

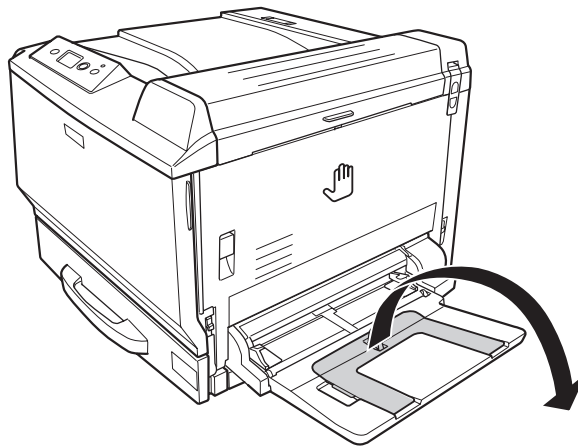

3. Load a stack of the desired paper with the printable surface facing down. Then slide the paper guides to get a snug fit.

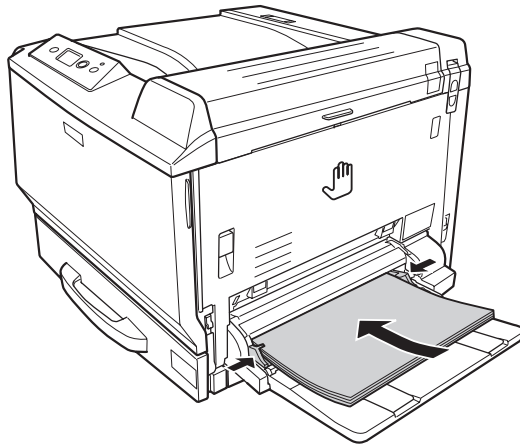

**Note:**

- ❑ *Make sure that you do not load paper beyond the limit mark.*

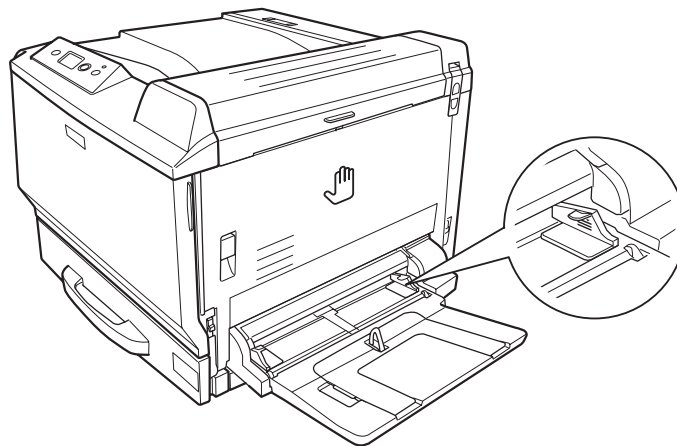

- ❑ *After loading paper, set the MP Tray Size/MP Tray Type settings to match the loaded paper size on the control panel. For details, see “Tray Menu” on page 84.*

### **Standard lower paper cassette**

This cassette gives you a second paper source in addition to the MP tray.

1. Pull out the paper cassette.

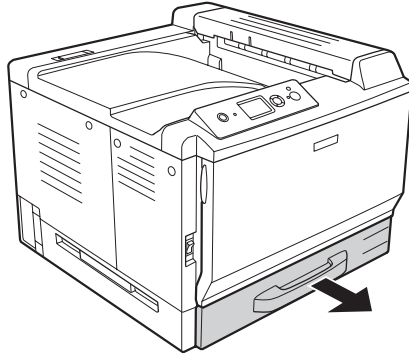

2. Push down the bottom plate on the paper cassette.

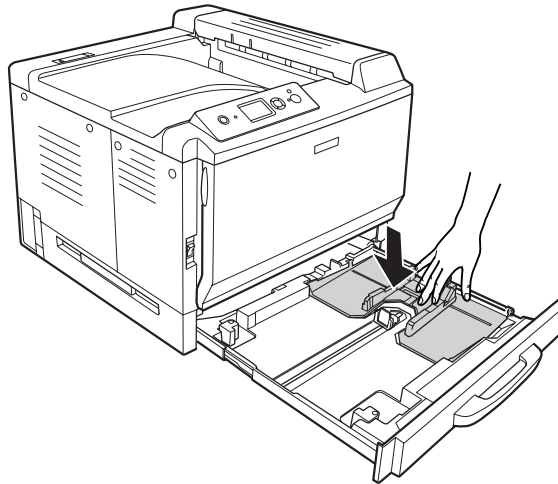

3. Pinch the knobs and slide the paper guides to accommodate the paper you are loading.

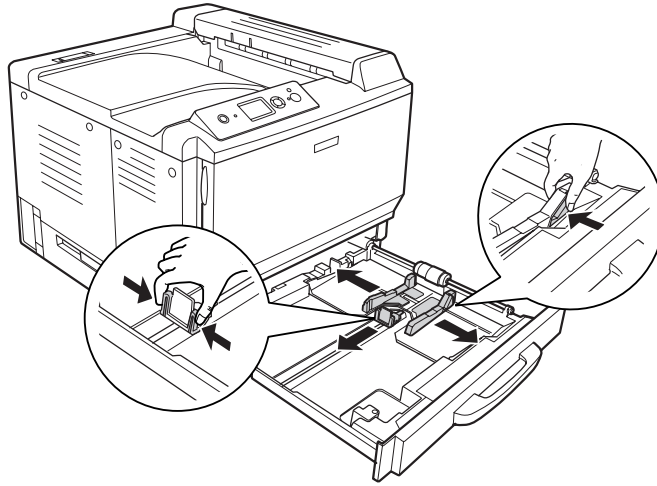

**Note:**

*When loading A3F size paper, slide the paper guides as wide as possible, and then turn the corner guides to close them.*

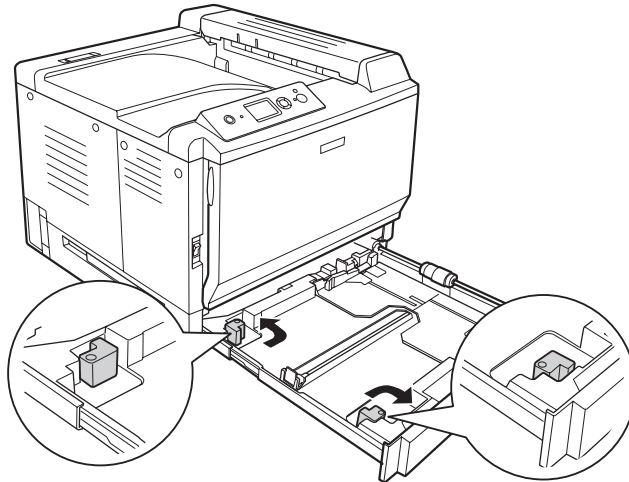



4. Load a stack of the desired paper on the center of the paper cassette with the printable surface facing up.

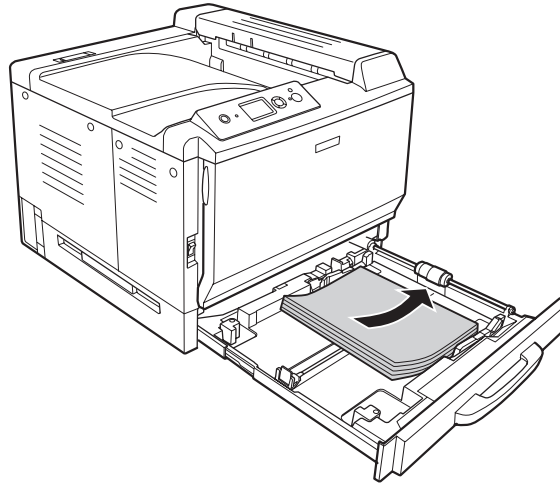

**Note:**

*Make sure that you do not load paper beyond the limit mark.*

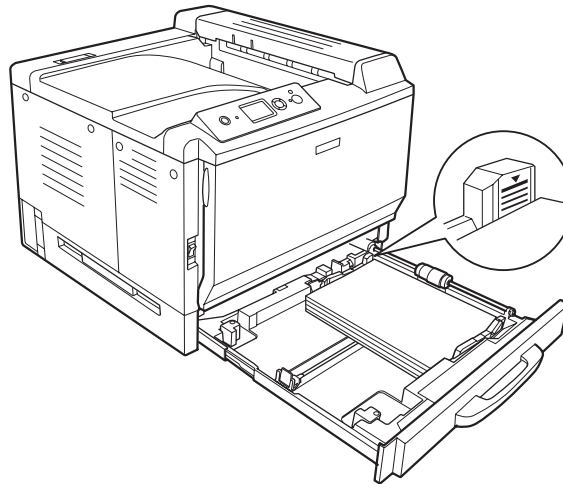

5. Pinch the knobs and slide the paper guides to fit the paper you are loading.

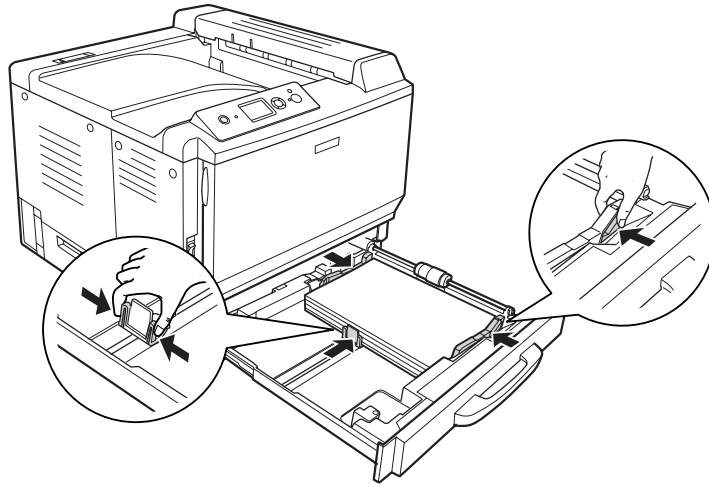

6. Reinsert the paper cassette into the printer.

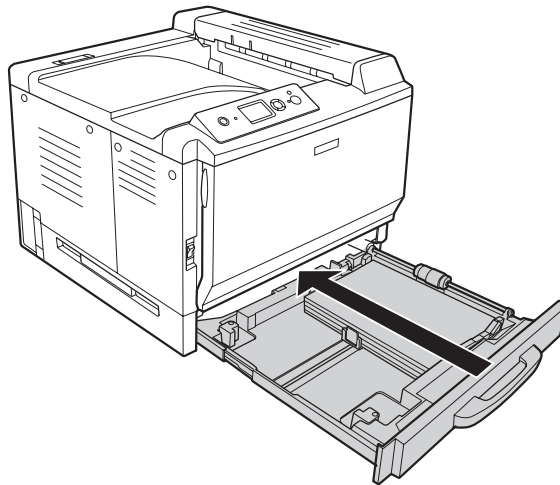

7. Affix the appropriate paper size label onto the front of the paper cassette.

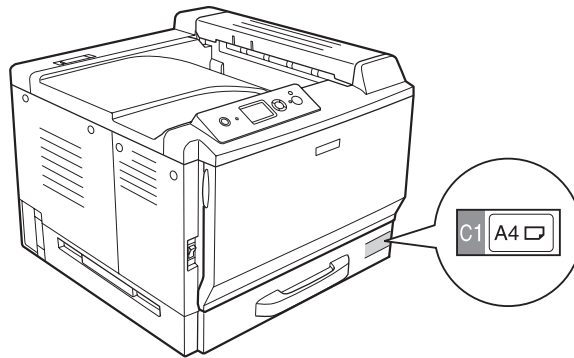

**Note:**  
After loading paper, set the *Cassette1 Size/Cassette1 Type* settings to match the loaded paper size and paper type on the control panel. For details, see “Tray Menu” on page 84.

## Optional paper cassette unit

**Note:**  
The instructions below describe loading paper in paper cassette 2 as an example.

1. Pull out the paper cassette.

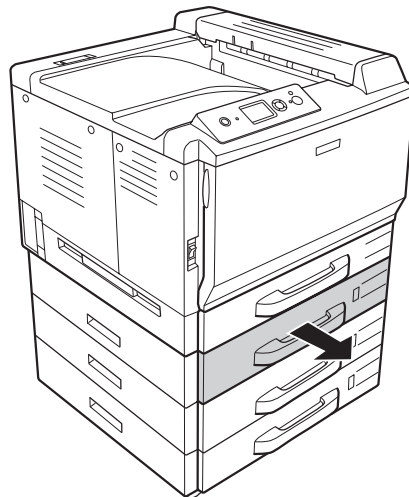

2. Pinch the knobs and slide the paper guides to accommodate the paper you are loading.

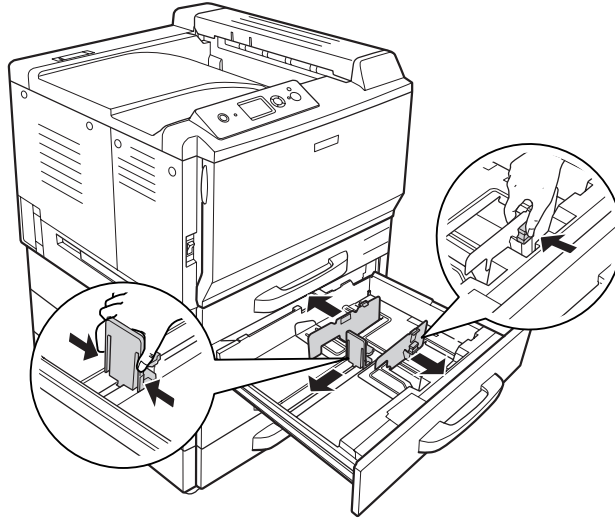

3. Load a stack of the desired paper on the center of the paper cassette with the printable surface facing up.

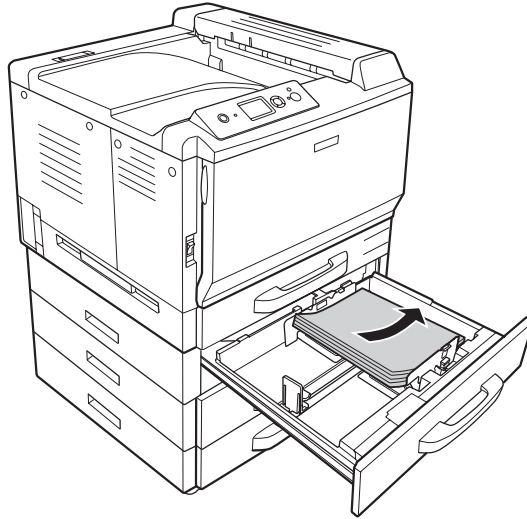

**Note:**

*Make sure that you do not load paper beyond the limit mark.*

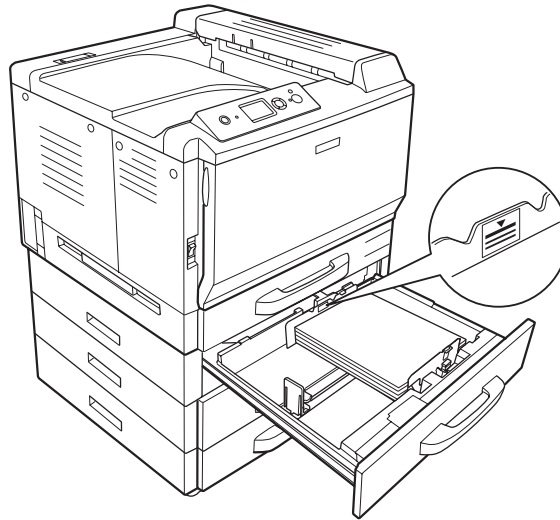

4. Pinch the knobs and slide the paper guides to fit the paper you are loading.

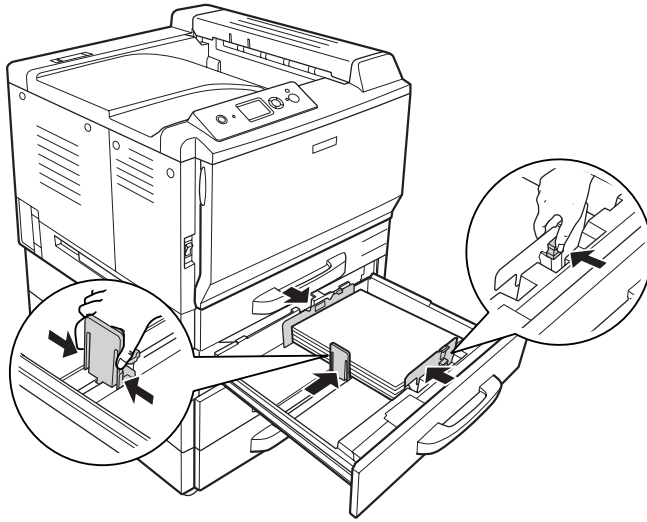

5. Reinsert the paper cassette into the printer.

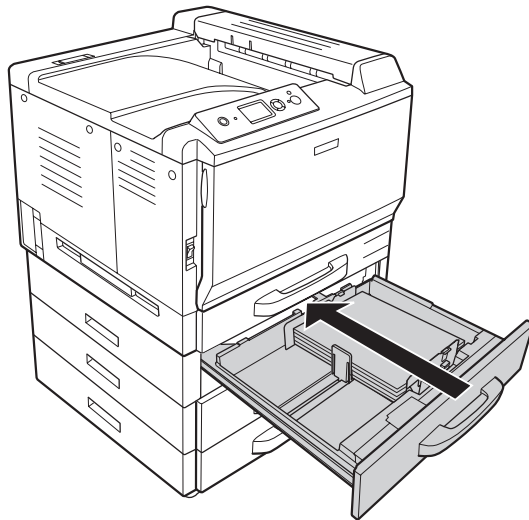

6. Affix the appropriate paper size label onto the front of the paper cassette.

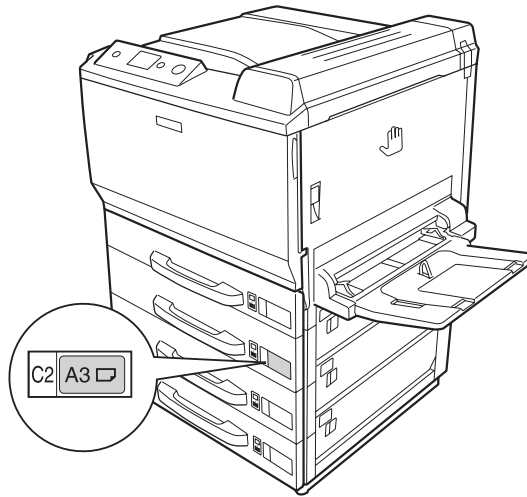

**Note:**

*After loading paper, set the Cassette2 Size/Cassette2 Type settings to match the loaded paper size and paper type on the control panel. For details, see “Tray Menu” on page 84.*

## **Output tray**

The output tray is located on the top of the printer. Since printouts are output face-down, this tray is also referred to as the face-down tray. Up to 500 sheets can be stacked when using the plain paper.

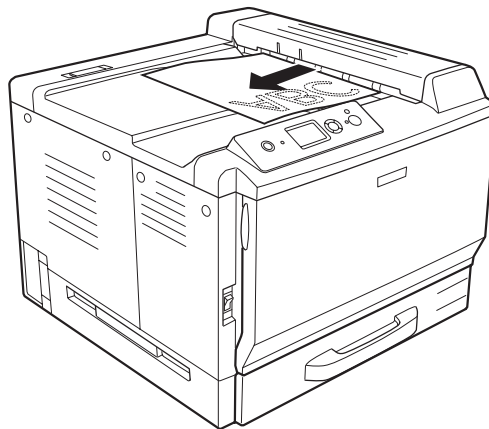

---

## Selecting and Using Print Media

You can use special media, such as labels, envelopes, thick paper, EPSON Color Laser Coated Paper, and Epson Color Laser Transparencies.

When loading special media, you should make paper settings. You can also make these settings on the **Tray Menu** in the control panel. See “Tray Menu” on page 84.

**Note:**

*Since the quality of any particular brand or type of media may be changed by the manufacturer at any time, EPSON cannot guarantee the quality of any type of media. Always test samples of media stock before purchasing large quantities or printing large jobs.*

## Labels

**Available labels:**

- Labels designed for laser printers or plain-paper copiers
- Labels that completely cover the backing sheet, with no gaps between the individual labels

**Available paper source:**

- MP tray

**Printer driver settings:**

Paper Size: A4, LT

Paper Source: MP Tray

Paper Type: Labels

**Note:**

- Depending on the quality of labels, the printing environment, or the printing procedure, labels might be wrinkled. Make a trial print run before you print on a lot of labels.*
- Duplex printing is not available for labels.*
- Press a sheet of paper on top of each sheet of labels. If the paper sticks, do not use those labels in your printer.*



## Envelopes

### Available envelopes:

- Envelopes that have no glue or no tape



### **Cautions**

*Do not use window envelopes. The plastic on most window envelopes will melt.*

### Available paper source:

- MP tray

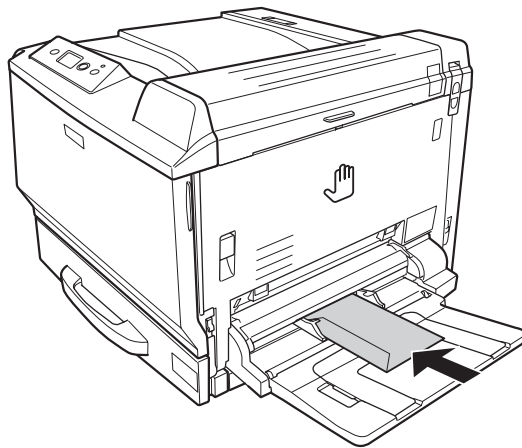

### Printer driver settings:

Paper Size: Mon, C10, DL, C5, C6, IB5

Paper Source: MP Tray

### **Note:**

- Depending on the quality of envelopes, the printing environment, or the printing procedure, envelopes might be wrinkled. Make a trial print run before you print on a lot of envelopes.*
- Duplex printing is not available for envelopes.*

- ❑ When printing on envelopes, open cover A and cover B, and then push down the release levers at both sides of the fuser unit until they stop. It may reduce the wrinkles in the envelopes. When using paper other than envelopes, be sure to push the levers back up.

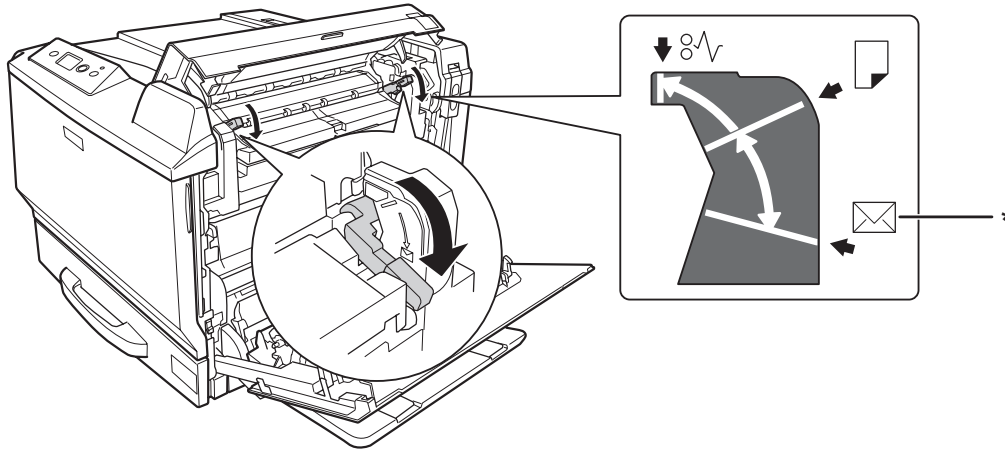

\* envelope position



### Warnings

Unless specifically instructed in this guide, be careful not to touch the fuser, which is marked **CAUTION HIGH TEMPERATURE**, or the surrounding areas. If the printer has been in use, the fuser and the surrounding areas may be very hot. If you must touch one of these areas, wait 30 minutes to allow the heat to subside before doing so.

## Thick paper

### Available paper source:

- ❑ MP tray

### Printer driver settings:

Paper Size: A4, A3, A5, B4, B5, LT, HLT, LGL, GLT, GLG, B, EXE, F4, A3F

Paper Source: MP Tray

Paper Type: Thick/Thick (Back) (for 91 to 150 g/m<sup>2</sup> paper), Extra Thick/Extra Thick (Back) (for 151 to 209 g/m<sup>2</sup> paper), Super Thick/Super Thick (Back) (210 to 256 g/m<sup>2</sup> paper)

## **EPSON Color Laser Coated Paper**

### **Available paper source:**

- MP tray

### **Printer driver settings:**

Paper Size: A4, A3  
Paper Source: MP Tray  
Paper Type: Coated, Coated (Back)

#### **Note:**

*EPSON Color Laser Coated Paper may not be fed properly, depending on the temperature and humidity condition, because it is coated with the special materials. If this happens, load it one sheet at a time from the MP tray.*

## **EPSON Color Laser Transparencies**

### **Available paper source:**

- MP tray

### **Printer driver settings:**

Paper Size: A4  
Paper Source: MP Tray  
Paper Type: Transparency

#### **Note:**

*Duplex printing is not available for transparencies.*

## **Custom paper size**

### **Available paper size:**

- 90 × 139.7 mm to 311.2 × 1200 mm

**Available paper source:**

- MP tray

**Printer driver settings:**

Paper Size: User Defined Size

Paper Source: MP Tray

Paper Type: Normal, Normal (Back), Transparency, Labels, Thick, Thick (Back), Extra Thick, Extra Thick (Back), Super Thick, Super Thick (Back), Coated, Coated (Back)

**Note:**

- Depending on the quality of the non-standard size paper, the printing environment, or the printing procedure, the paper might skew. Make a trial print run before you print on a lot of non-standard size paper.
- For Windows, access the printer driver, then select **User Defined Size** from the Paper Size list on the Basic Settings tab. In the User Defined Paper Size dialog box, adjust the Paper Width, Paper Length, and Unit settings to match your custom paper. Then click **OK** and your custom paper size will be saved.
- For Mac OS X 10.4 or later, follow the steps below to save your custom paper size.
  1. Open the Page Setup dialog box.
  2. Select **Manage Custom Sizes** from the Paper Size drop-down list.
  3. Click .
  4. Double-click **Untitled** and enter the setting's name.
  5. Specify the paper size and click **OK**.
- For Mac OS X 10.3.9, follow the steps below to save your custom paper size.
  1. Open the Page Setup dialog box.
  2. Select **Custom Page Size** from the Settings drop-down list.

3. Click **New**.

4. Enter the setting's name and specify the paper size, and then click **OK**.

- ❑ The saved paper sizes can only be used with the printer driver you saved them to. Even if multiple printer names are set for a printer driver, the settings can be available only for the printer name in which you saved the settings.
- ❑ When sharing the printer on a network, you cannot create User defined size at the client.
- ❑ If you cannot use the printer driver as explained above, make this setting at the printer by accessing the control panel's Printing Menu and selecting CTM (custom) as the Page Size setting.

---

## Canceling a Print Job

### From the printer

Press the  **Cancel Job** button on the printer's control panel.

### From the computer

#### For Windows users

Double-click your printer's icon on the taskbar. Select the job in the list, then click **Cancel** from the Document menu.

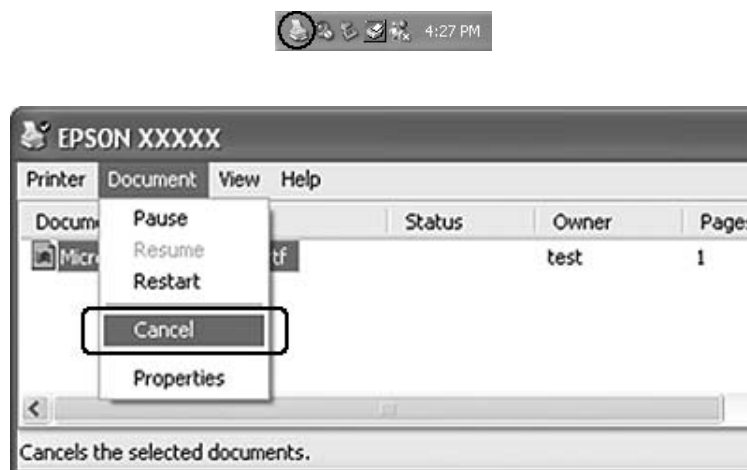

## For Mac OS X users

Open **Print & Fax** (for Mac OS X 10.5) or **Printer Setup Utility** (for Mac OS X 10.4 or below) and double-click your printer from the printer list. Then, select the job in the list and select **Delete Job** from the Jobs menu.

## Setting the Print Quality

You can change the print quality of printouts through settings in the printer driver.

In the Automatic setting, you can select a print mode according to your printing purpose. The printer driver makes optimal settings depending on the print mode you have selected. In the Advanced setting, you have more setting options.

### Note:

The printer driver's online help provides details on printer driver settings.

## Using the Automatic setting

### For Windows users

1. Click the **Basic Settings** tab.
2. Click **Automatic**, then choose desired printing quality.

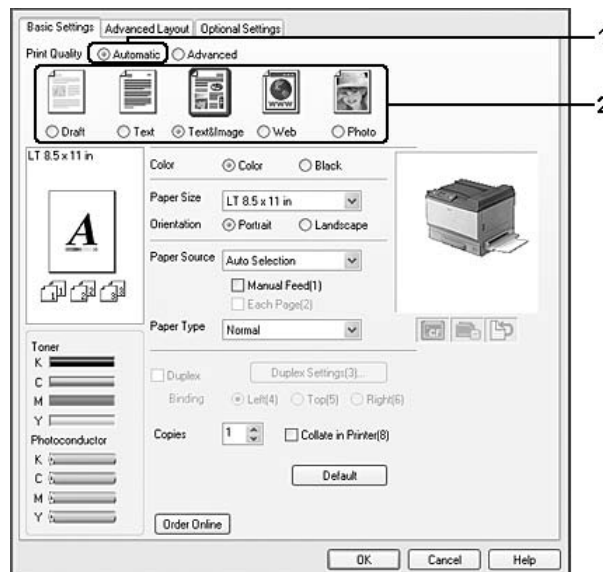

3. Click **OK**.

### For Mac OS X 10.5 users

1. Open the print dialog box.
2. Select **Printer Settings** from the drop-down list and click the **Basic Settings** button.
3. Choose the resolution from the Print Quality drop-down list.

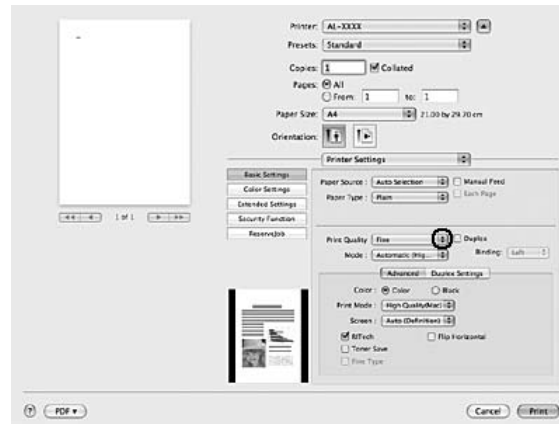

#### **Note:**

Make sure **Automatic (Standard)** or **Automatic (High Quality)** is selected in the Mode drop-down list.

### For Mac OS X 10.4 or below users

1. Open the Print dialog box.
2. Select **Printer Settings** from the drop-down list, and select the **Basic Settings** tab.

3. Select **Automatic**, then choose the resolution from the drop-down list.

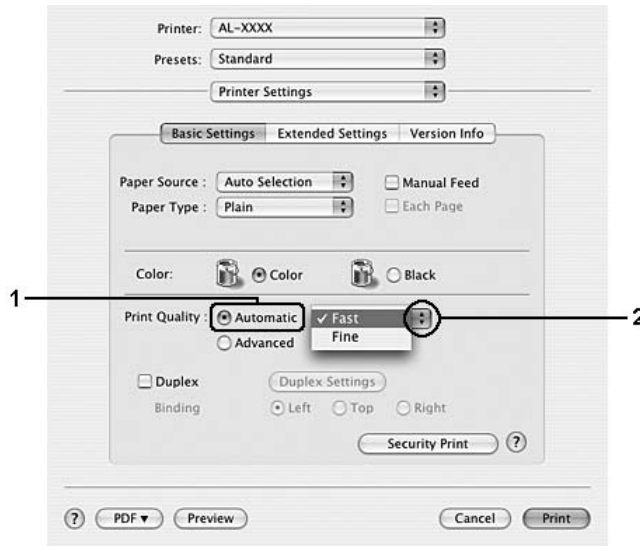

## Using the Advanced setting

For Windows users

1. Click the **Basic Settings** tab.
2. Select **Advanced**. Then select the most appropriate setting from the list according to the type of document or image you want to print.

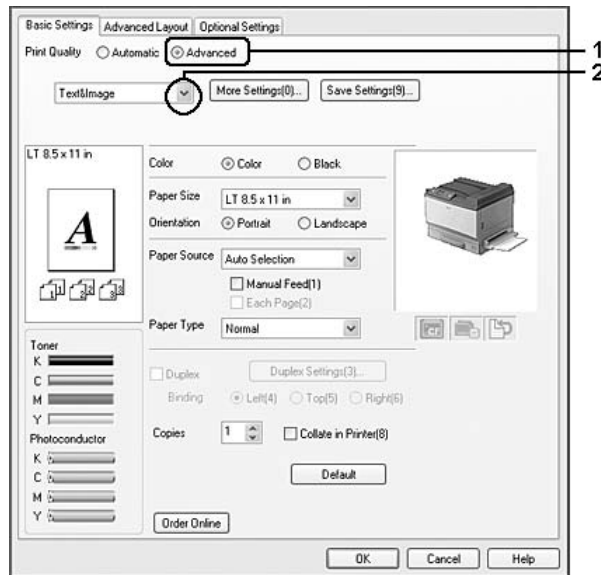



When you choose a predefined setting, other settings such as Print Quality and Screen are set automatically. Changes are shown in the current settings list on the Setting Information dialog box that appears by pressing the **Setting Info.** button on the Optional Settings tab.

#### For Mac OS X 10.5 users

1. Open the print dialog box.
2. Select **Printer Settings** from the drop-down list and click the **Basic Settings** button.
3. Select the most appropriate setting from the Mode drop-down list according to the type of document or image you want to print.

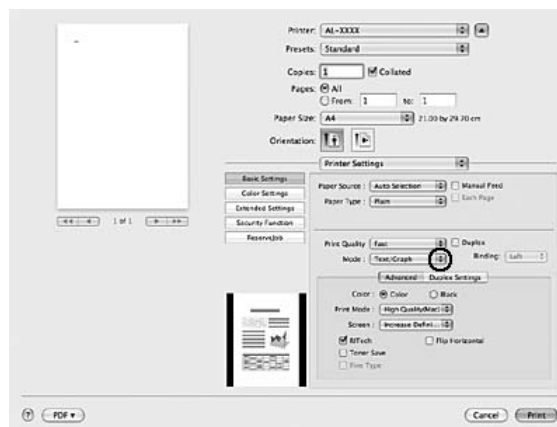

When you choose a predefined setting, other settings such as Print Quality and Screen are set automatically. Changes are shown in the Summary drop-down list in the Print dialog box.

#### For Mac OS X 10.4 or below users

1. Open the Print dialog box.
2. Select **Printer Settings** from the drop-down list, and select the **Basic Settings** tab.

3. Select **Advanced**, then select the most appropriate setting from the drop-down list according to the type of document or image you want to print.

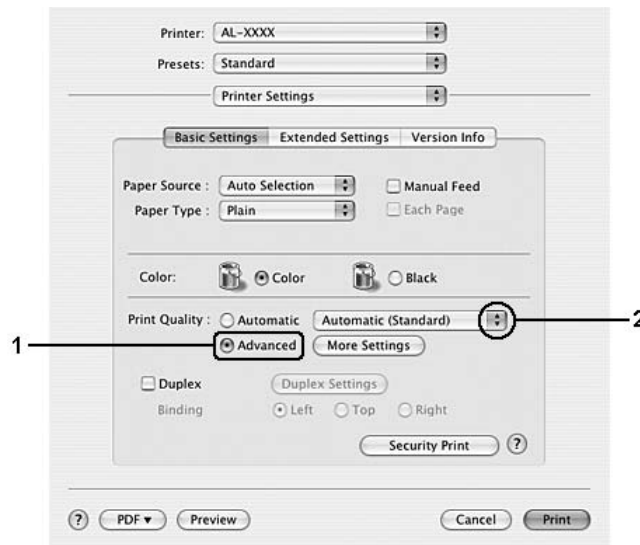

When you choose a predefined setting, other settings such as Print Quality and Screen are set automatically. Changes are shown in the Summary drop-down list in the Print dialog box.

## Customizing print settings



If you need to change detailed settings, make the settings manually.

### For Windows users

1. Click the **Basic Settings** tab.
2. Select **Advanced**, then click **More Settings**.
3. Make appropriate settings. For details about each setting, see online help.
4. Click **OK**.

### For Mac OS X 10.5 users

1. Open the print dialog box.
2. Select **Printer Settings** from the drop-down list and click the **Basic Settings** button.

3. Select the **Advanced** tab, then make appropriate settings. For details about each setting, click the  button.
4. Click the **Color Settings** button, then make appropriate settings. For details about each setting, click the  button.

#### For Mac OS X 10.4 or below users

1. Open the Print dialog box.
2. Select **Printer Settings** from the drop-down list, and select **Basic Settings** tab.
3. Select **Advanced**, then click **More Settings**.
4. Make appropriate settings. For details about each setting, click the  button.
5. Click **OK**.

### ***Saving your settings***

You can save your custom settings.

#### **Note:**

- You cannot use a predefined setting name for your custom settings.*
- The saved custom settings can only be used with the printer driver you saved them to. Even if multiple printer names are set for a printer driver, the settings can be available only for the printer name in which you saved the settings.*
- You cannot delete predefined settings.*

#### For Windows users

#### **Note:**

*When sharing the printer on a network, Save Settings is grayed out and you cannot create a custom setting at the client.*

1. Click the **Basic Settings** tab.
2. Select **Advanced**, then click **Save Settings** to open the Custom Settings dialog box.
3. Type a name for your custom settings in the Name box, then click **Save**.

Your settings will appear in the list on the Basic Settings tab.

**Note:**

*To delete a custom setting, follow the step 1 and 2, select the setting in the Custom Settings dialog box, then click **Delete**.*

You can create new settings in the More Settings dialog box. When you create new settings, Custom Settings is displayed in the list on the Basic Settings tab. In this case, the original setting is not overwritten. To save the new settings, save them under a new name.

**For Mac OS X users**

1. Open the Print dialog box.
2. Click **Save** or **Save As** in the Presets.
3. Type a name for your custom settings in the name box, then click **OK**.

Your settings will appear in the Presets drop-down list.

**Note:**

*To delete a custom setting, select the setting, then select **Delete** in the presets drop-down list.*

## **Toner Save mode**

To reduce the amount of toner used in printing documents, you can print rough drafts using the Toner Save mode.

**For Windows users**

1. Click the **Basic Settings** tab.
2. Select **Advanced**, then click **More Settings** to open the More Settings dialog box.
3. Select the **Toner Save** check box, then click **OK**.

**For Mac OS X 10.5 users**

1. Open the print dialog box.
2. Select **Printer Settings** from the drop-down list and click the **Basic Settings** button.

3. Select the **Advanced** tab, then select the **Toner Save** check box.

#### **For Mac OS X 10.4 or below users**

1. Open the print dialog box.
2. Select **Printer Settings** from the drop-down list, and select **Basic Settings** tab.
3. Select **Advanced**, then click **More Settings**.
4. Select the **Toner Save** check box, then click **OK**.

### **Monochrome Model Compatibility mode**

When the following occurs while printing in black-and-white, select the Monochrome Model Compatibility check box on the advanced settings screen in the printer driver.

- The text and lines are too thin.
- The print data size is too large.

**Note:**

*When you use this mode, the amount of toner consumption increases.*

---

## **Setting the Advanced Layout**

### **Duplex printing (with the Duplex Unit)**

This function allows you to print on both sides of the paper automatically by installing the optional Duplex Unit.

#### **For Windows users**

1. Click the **Basic Settings** tab.

2. Select the **Duplex** check box, then select **Left, Top**, or **Right** as the binding position.

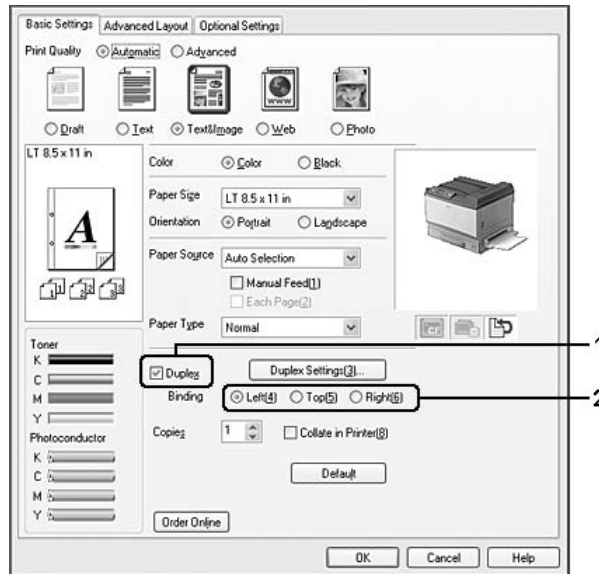

**Note:**

The **Duplex** check box appears only when the Duplex Unit is recognized by the printer driver. If it is not recognized, confirm that the option is set to **Installed** on the **Optional Settings** tab. If necessary, update the installed option information manually. For details, see “Making Optional Settings” on page 217.

3. If you want to make detailed settings, click **Duplex Settings** to open the Duplex Settings dialog box.
4. Make appropriate settings. For details about each setting, see online help.
5. Click **OK**.

**For Mac OS X 10.5 users**

1. Open the print dialog box.
2. Select **Printer Settings** from the drop-down list and click the **Basic Settings** button.

3. Select the **Duplex** check box, then select **Left, Top,** or **Right** as the binding position.

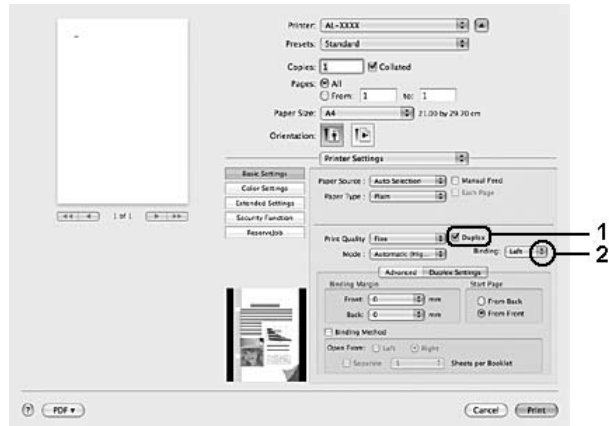

4. If you want to make detailed settings, select the **Duplex Settings** tab.
5. Make appropriate settings. For details about each setting, see online help.

**For Mac OS X 10.4 or below users**

1. Open the Print dialog box.
2. Select **Printer Settings** from the drop-down list, and select the **Basic Settings** tab.
3. Select the **Duplex** check box, then select **Left, Top,** or **Right** as the binding position.

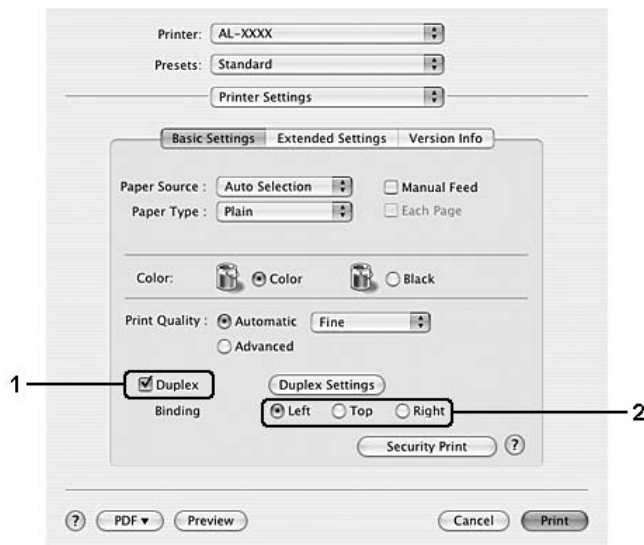

4. If you want to make detailed settings, click **Duplex Settings** to open the Duplex Settings dialog box.
5. Make appropriate settings. For details about each setting, see online help.
6. Click **OK**.

## Modifying the print layout

This function allows you to print multiple pages on single sheets of paper.

### For Windows users

1. Click the **Advanced Layout** tab.
2. Select the **Print Layout** check box and the number of pages you want to print on one sheet of paper.
3. If you want to make detailed settings, click **More Settings**. The Print Layout Settings dialog box appears.

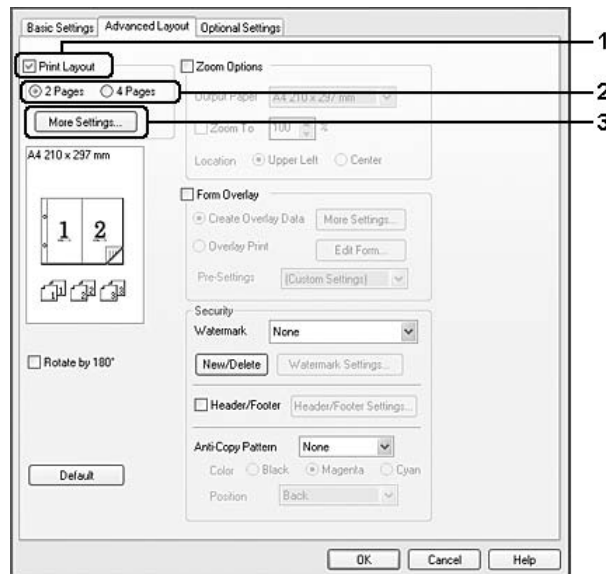

4. Make appropriate settings. For details about each setting, see online help.
5. Click **OK**.



### For Mac OS X users

1. Open the Print dialog box.
2. Select **Layout** from the drop-down list.
3. Select the number of pages you want to print on one sheet of paper from the drop-down list.

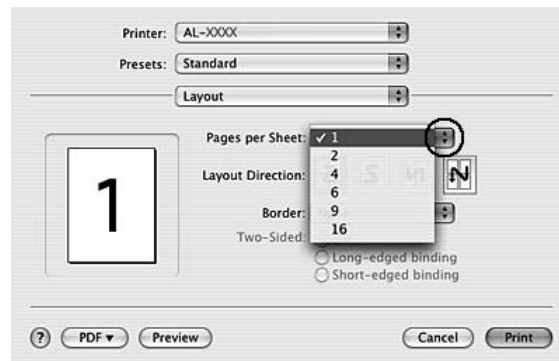

4. Click **Print**.

### Resizing printouts

This function allows you to enlarge or reduce your document.

#### For Windows users

1. Click the **Advanced Layout** tab.

2. Select the **Zoom Options** check box.

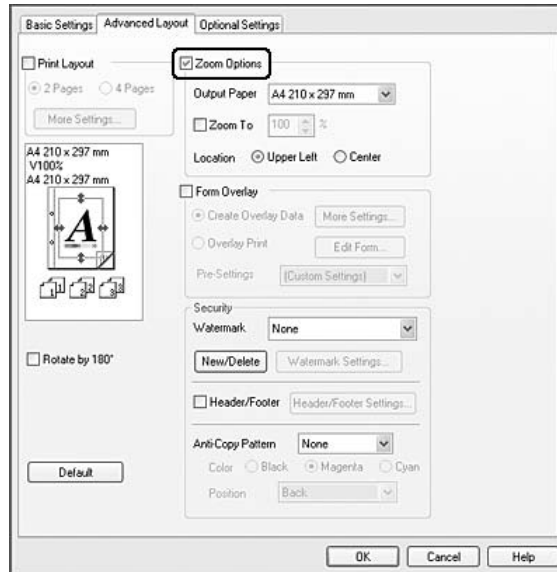

3. If you want to resize pages automatically to fit the output paper, select the desired paper size from the Output Paper drop-down list.  
If you want to resize pages by a specified magnification, select the **Zoom To** check box, then specify the percentage. You can also select the output paper size.
4. Select **Upper Left** (to print reduced page image at upper left corner of the paper) or **Center** (to print reduced page image with centering) for Location setting.

**Note:**

*This setting is not available when you select **Zoom To** check box.*

5. Click **OK**.

**For Mac OS X users**

**Note:**

- The enlarging or reducing rate is automatically specified according to the paper size you select.*
  - This function is not available with Mac OS X 10.3.9.*
1. Open the Print dialog box.
  2. Select **Paper Handling** from the drop-down list.

3. Select **Scale to fit paper size** and select the desired paper size from the drop-down list.

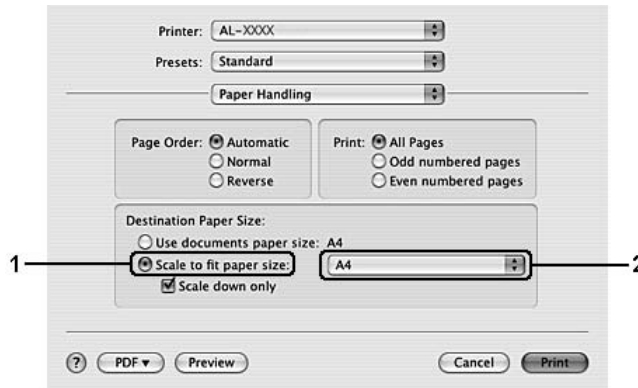

**Note:**

If you select **Scale down only**, your documents are not enlarged even if you select the large paper size.

## Printing watermarks

This function allows you to print a text-based or image-based watermark on your document.

### For Windows users

1. Click the **Advanced Layout** tab.

2. Select a watermark that you want to use from the Watermark drop-down list.

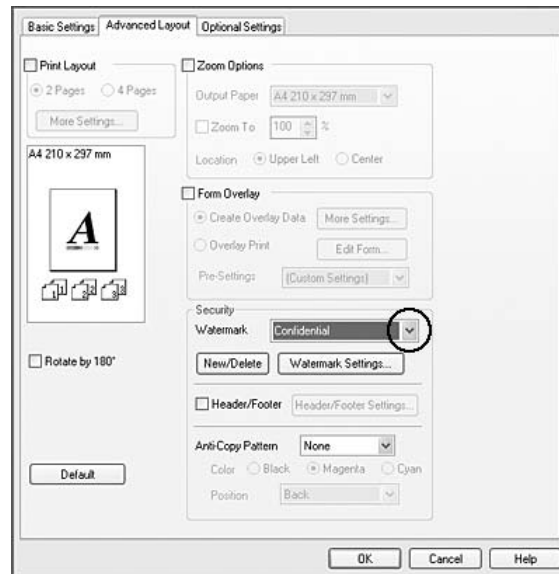

3. If you want to make detailed settings, click **Watermark Settings**, and make appropriate settings. For details about each setting, see online help.
4. Click **OK**.

#### For Mac OS X 10.5 users

1. Open the print dialog box.
2. Select **Printer Settings** from the drop-down list and click the **Security Function** button.
3. Select the **Watermark Settings** tab.

4. Select the **Watermark** check box.

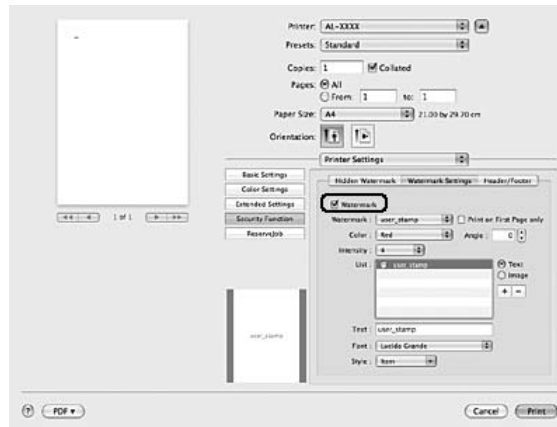

5. Select a watermark from the Watermark drop-down list.
6. If you want to make detailed settings such as Color and Intensity, make appropriate settings. For details about each setting, see online help.

#### For Mac OS X 10.4 or below users

1. Open the Print dialog box.
2. Select **Printer Settings** from the drop-down list, and select the **Basic Settings** tab.
3. Click **Security Print**.

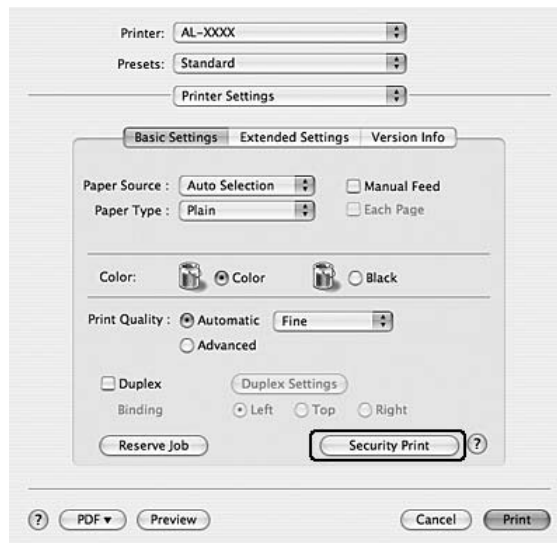

4. Select the **Watermark** check box.
5. Select a watermark from the Watermark drop-down list.
6. If you want to make detailed settings, click **Watermark Settings**, and make appropriate settings. For details about each setting, see online help.
7. Click **OK**.

### ***Making a new watermark***

#### **For Windows users**

1. Click the **Advanced Layout** tab.
2. Click **New/Delete**.
3. Select **Text** or **BMP** and type a name for the new watermark in the Name box.
4. If you select **Text**, type the watermark text in the Text box. If you select **BMP**, click **Browse**, select the BMP file you want to use, then click **Open**.
5. Click **Save**. Your watermark will appear in the List box.

#### **Note:**

- To edit the saved text watermark, select it from the List box, then follow the steps 4 and 5.*
- To remove the saved watermark, select it from the List box, then click **Delete**. After removing it, be sure to click **OK** to close the dialog box.*

6. Click **OK**.

#### **Note:**

- You can register up to 10 original watermarks.*
- The saved watermarks can only be used with the printer driver you saved them to. Even if multiple printer names are set for a printer driver, the settings can be available only for the printer name in which you saved the settings.*
- When sharing the printer on a network, you cannot create a user defined watermark at the client.*

#### **For Mac OS X 10.5 users**

1. Open the print dialog box.
2. Select **Printer Settings** from the drop-down list and click the **Security Function** button.
3. Select the **Watermark Settings** tab, then select the **Watermark** check box.

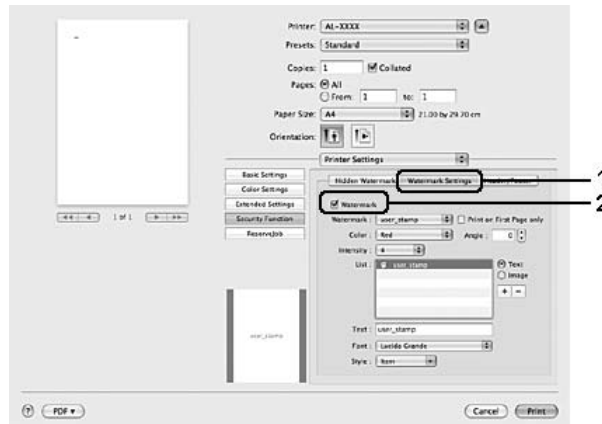

4. Select Text or Image, then click  +.
5. If you select **Text**, type the watermark text, then select Font and Style. If you select **Image**, select an image file (PDF, PNG, or JPG), then click **Open**.

**Note:**

- To edit the watermark name, double-click the watermark in the List box, then type the watermark name.
- To remove the created watermark, select it from the List box, and click  -. Then, click **OK**.

6. Select a custom water mark that has been saved from the Watermark drop-down list.

**Note:**

You can register up to 32 custom watermarks.

**For Mac OS X 10.4 or below users**

1. Open the Print dialog box.
2. Select **Printer Settings** from the drop-down list, and select the **Basic Settings** tab.

3. Click **Security Print**.

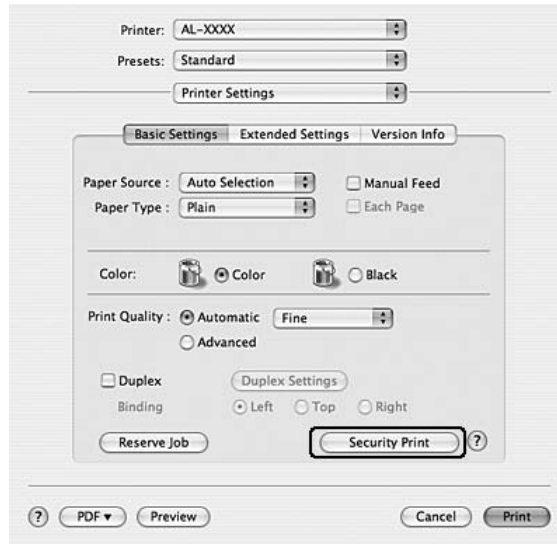

4. Select the **Watermark** check box, then click **Watermark Settings**.
5. Click **New/Delete**.
6. Click **Add Text** or **Add Image** on the Custom Watermark Settings dialog box.
7. If you select **Add Text**, type the watermark text, select the **Font** and **Style**, then click **OK** on the Edit Text dialog box. If you select **Add Image**, select an image file (PDF, PNG, or JPG), then click **Open**.

**Note:**

To type the watermark text, open the Text Input dialog box by clicking the text box. Type the text, then click **OK**.

8. Type the file name in the Watermark box, then click **Save**.

**Note:**

- To edit the saved text watermark, select it from the Mark List box, then click **Edit Text**. After editing, be sure to click **Save**.
- To remove the saved watermark, select it from the Mark List box, then click **Mark Delete**. After removing it, be sure to click **Save**.



9. Select a custom watermark that has been saved from the Watermark drop-down list on the Watermark Setting dialog box, and then click **OK**.

**Note:**

You can register up to 32 custom watermarks.

## Printing headers and footers

This function allows you to print user name, computer name, date, time, or collate number, at the top or bottom of each page in a document.

### For Windows users

1. Click the **Advanced Layout** tab.
2. Select the **Header/Footer** check box, then click **Header/Footer Settings**.

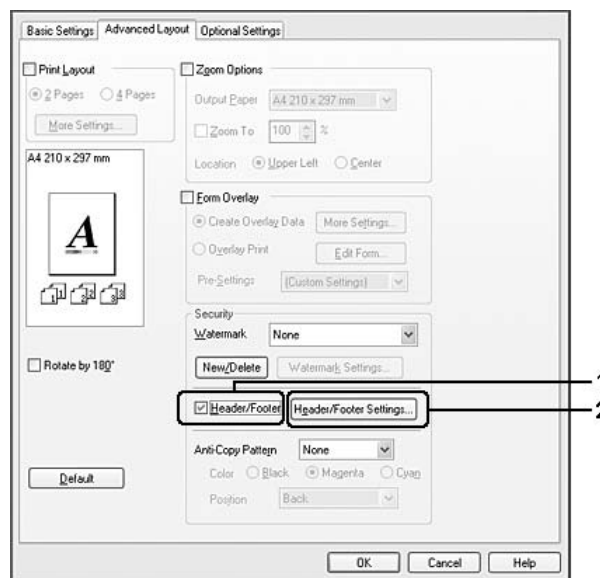

3. Select the items from the drop-down list.

**Note:**

- If you select **Collate Number**, the number of copies is printed.
- When using the Reserve Job function, you cannot select **Collate Number**.

4. Click **OK**.

### For Mac OS X 10.5 users

1. Open the print dialog box.
2. Select **Printer Settings** from the drop-down list and click the **Security Function** button.
3. Select the **Header/Footer** tab, then select the **Header/Footer** check box.

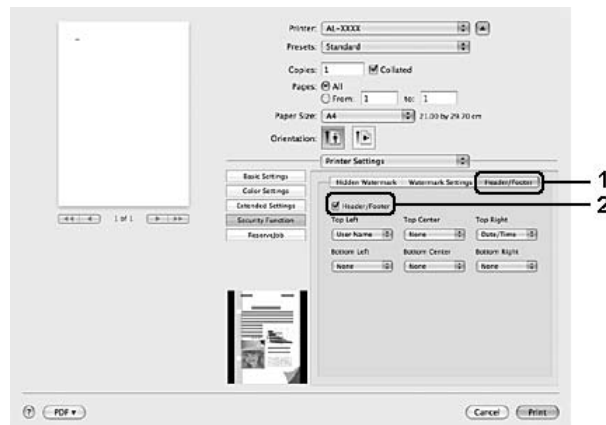

4. Select the items from the drop-down list.

**Note:**

If you select **Collate Number**, the number of copies is printed.

### For Mac OS X 10.4 or below users

1. Open the Print dialog box.
2. Select **Printer Settings** from the drop-down list, and select **Basic Settings** tab.

3. Click **Security Print**.

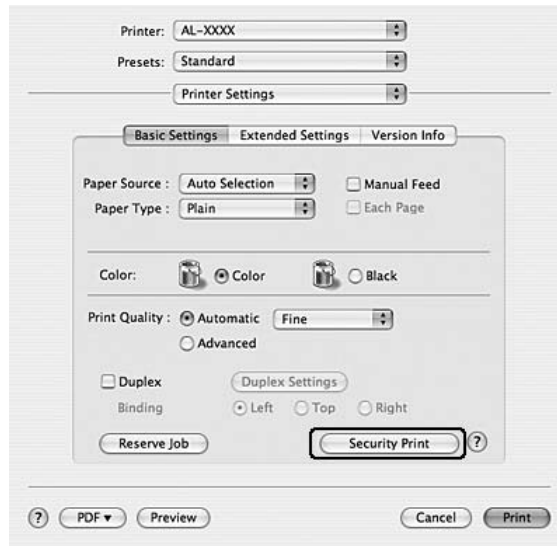

4. Select the **Header/Footer** check box, then click **Header/Footer Settings**.
5. Select the items from the drop-down list.

**Note:**

If you select **Collate Number**, the number of copies is printed.

6. Click **OK**.

## Printing with an overlay

This function allows you to print a standard form or letterhead onto the original document.

**Note:**

- This function is for Windows only.
- The overlay function is available only when **High Quality (Printer)** is selected for the Printing Mode in the Extended Settings dialog box from the Optional Settings tab.
- When printing in black-and-white with this function, Monochrome Model Compatibility is automatically enabled. This prints text and lines heavily, increasing the amount of toner consumption.

## Creating an overlay

1. Click the **Advanced Layout** tab.
2. Select the **Form Overlay** check box.

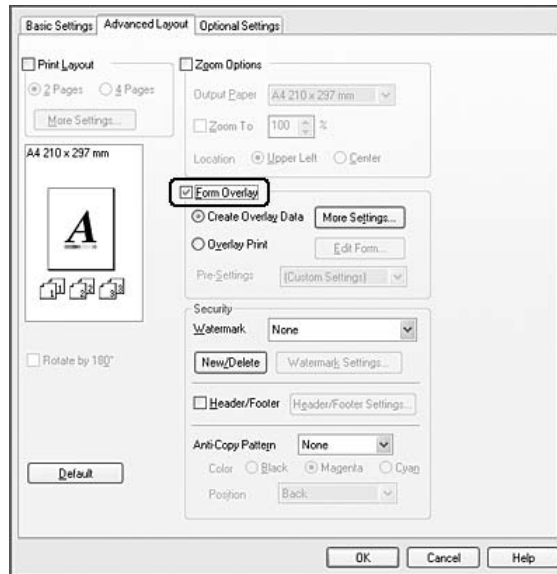

3. Select **Create Overlay Data**, then click **More Settings**. The Create Form dialog box appears.
4. Type the form name in the Form Name box and its description in the Description box.
5. Select **Foreground Document** or **Background Document** to specify whether the overlay will be printed as foreground or background of the document.
6. Select the **Assign to Paper Source** check box to display the form name in the Paper Source drop-down list on the Basic Settings tab.
7. Click **OK**.

### Note:

- ❑ To change the settings of the overlay form data you created, access the printer driver and repeat all the steps above. Note that on the step 5, select **Overlay Print**, then click **Edit Form**.
- ❑ The following 9 characters cannot be used for form names: \ : \* ? " < > |.

## Printing an overlaid document

You can select the registered form data from the Paper Source drop-down list on the Basic Settings tab. For registering form data in the Paper Source, see step 8 in “Creating an overlay” on page 68. If overlay form data is not registered in the Paper Source or if you want to make detailed settings, follow the steps below.

1. Click the **Advanced Layout** tab.
2. Select the **Form Overlay** check box.
3. Select the **Overlay Print** check box, then click **More Settings**. The Form Selection dialog box appears.
4. Make appropriate settings. For details about each setting, see online help.

**Note:**

*If you cannot select the form from the application, access the printer driver from the operating system. For details, see “Accessing the printer driver” on page 216.*

5. Click **OK**.

## Saving an overlaid form pre-settings

This function allows you to save the settings you made from “Creating an overlay” on page 68.

1. From the Form Selection dialog box, click **Save/Delete**. To open the dialog box, see “Printing an overlaid document” on page 69.
2. Type the pre-settings name in the Form Pre-Settings Name box, then click **Save**. Your pre-settings name will appear in the Form Pre-Settings drop-down list in the Form Selection dialog box.
3. Click **OK**. Your pre-settings name will appear in the Pre-Settings drop-down list in the Advanced Layout dialog box.

**Note:**

- To delete an overlaid form pre-setting, follow the step 1, select the pre-settings name you want to delete from Form Pre-Settings drop-down list, click **Delete**, and then click **OK**.*
- You can save up to 20 pre-settings.*

## ***Printing with an overlay (with the storage)***

This function allows you to register the overlay form data on the storage. The storage is the optional CompactFlash memory installed in the printer.

This function is available only when the following conditions are satisfied.

- The optional CompactFlash memory is installed on the printer.
- Update the Printer Option Info Automatically** is selected under the Optional Settings tab on the printer driver.
- High Quality (Printer) mode is set.
- The printer is connected via a network.
- You are using Windows.
- EPSON Status Monitor is installed on the computer.
- Internet Explorer is running on the computer.

## ***Register the overlay form data on the storage***

**Note:**

*The form name must use only the characters shown below. A - Z, a - z, 0 - 9, and ! ' ) ( - \_ %*

1. Create the overlay form data. For details, see “Creating an overlay” on page 68.
2. Log in to Windows Vista, Vista x64, XP, XP x64, 2000, Server 2003, or Server 2003 x64 as an administrator.
3. From your operating system, click **Start** and access **Printers** (for Windows Vista or 2000) or **Printers and Faxes** (for Windows XP or Server 2003). Right-click your printer icon, then click **Properties**.
4. Click the **Optional Settings** tab.
5. Click **Register**. The Authentication dialog box appears.
6. Enter the password, and then click **OK**.  
The Register to Storage dialog box appears.

7. Select the form name from the Form Names list, and then click **Register**.

**Note:**

- Only form names that can be registered appear on the Form Names list.
  - Click **Print List** to print the form list registered in the printer.
8. Click **Back** to close the Register to Storage dialog box.
  9. Click **OK**.

### **Printing a overlaid document**

1. Click the **Advanced Layout** tab.
2. Select the **Form Overlay** check box.
3. Select the **Overlay Print** check box, then click **More Settings**. The Form Selection dialog box appears.
4. Select **CompactFlash in Printer** in the Current Source drop-down list.
5. Make appropriate settings. For details about each setting, see online help.
6. Click **OK** in the Form Selection dialog box.
7. Click **OK** in the Advanced Layout tab.

### **Delete the overlay form data on the storage**

1. Follow the step 2 to 4 of “Register the overlay form data on the storage” on page 70.
2. Click **Delete**. The Authentication dialog box appears.
3. Enter the password, and then click **OK**.  
The Delete from Storage dialog box appears.

4. If you delete all overlay form data, click the **All** button, then click **Delete**. If you want to delete some specific data, click the **Selected** button, enter the form name in the Form Name edit box, then click **Delete**.

**Note:**

- If you need the list of the registered overlay form data, click **Print List** to print it and confirm the form name. Also, if you need a sample print-out of the form data, enter the form name and click the **Print Sample** button.*
  - You can use the **Browse** button if the printer is connected through a network. Form names registered to the storage are displayed by clicking the **Browse** button.*
5. Click **Back**.
  6. Click **OK**.

## Printing the copy-protected document

This function allows you to print a document as a copy-protected document. When you try to copy a copy-protected document, "COPY" is printed several times on the document.

**Note:**

- Epson will not guarantee to secure from information leakage and any other damage by using this function, nor hidden letters appear in all cases.*
- Screen-tone may be too dark, hidden letters may not be printed on the entire print, or hidden letters may not appear when photocopied depends on the models, settings, and combinations of photocopiers, fax machine, input device such as digital cameras and scanners, output device such as printers; printer driver settings of this product; condition of consumables such as toner and output paper type.*

### For Windows users

**Note:**

*With the Anti-Copy function, the Print Quality setting is changed to **Fine**, and the Toner Save setting is disabled. The Screen setting is also changed to **Auto (Definition)** in color mode.*

1. Click the **Advanced Layout** tab.



2. Select **Copy** from the Anti-Copy Pattern drop-down list, and then select Color to print anti-copy pattern.

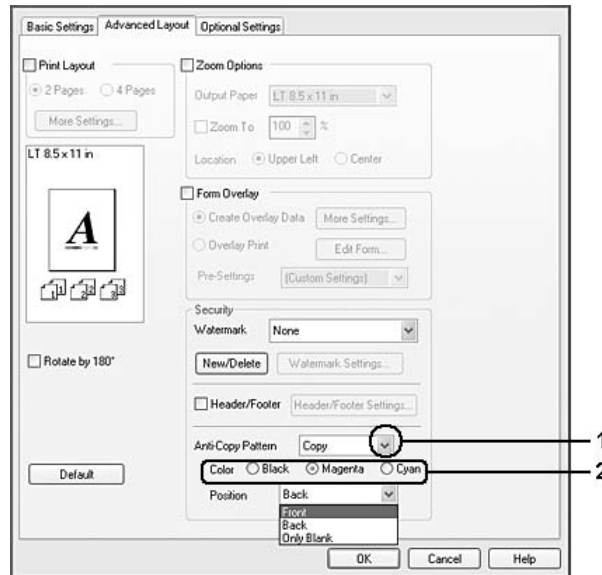

3. Select the position where the anti-copy pattern is printed. If you select **Front**, “COPY” is printed on the text and images. If you select **Back**, “COPY” is printed on the text but not on the images in the document. If you select **Only Blank**, “COPY” is printed on blank areas in the images as well as on the text.
4. Click **OK**.

#### For Mac OS X 10.5 users

##### Note:

With the Print Hidden Watermark function, the Print Quality setting is changed to **Fine**, the Toner Save setting is disabled, and the Print Mode setting is changed to **High quality (Mac)** or **High Quality (Printer)**. The Screen setting is also changed to **Auto (Definition)** in color mode.

1. Open the print dialog box.
2. Select **Printer Settings** from the drop-down list and click the **Security Function** button.

3. Select the **Hidden Watermark** tab, then select the **Print Hidden Watermark** check box.

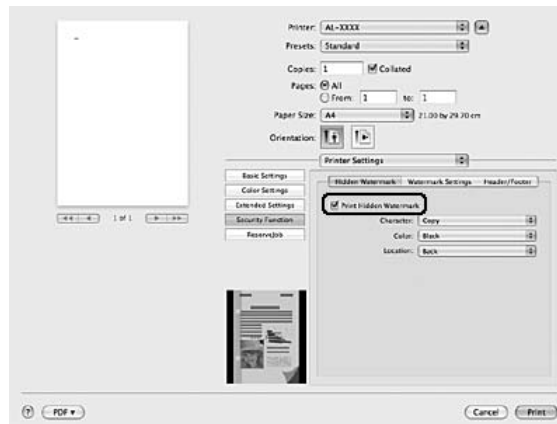

4. Select **Copy** from the Character drop-down list, and then select Color to print anti-copy pattern.
5. Select the position where the anti-copy pattern is printed. If you select **Front**, “COPY” is printed on the text and images. If you select **Back**, “COPY” is printed on the text but not on the images in the document. If you select **Only Blank**, “COPY” is printed on blank areas in the images as well as on the text.

#### For Mac OS X 10.4 or below users

##### **Note:**

With the Print Hidden Watermark function, the Print Quality setting is changed to **Fine**, the Toner Save setting is disabled, and the Print Mode setting is changed to **High quality (Mac)** or **High Quality (Printer)**. The Screen setting is also changed to **Auto (Definition)** in color mode.

1. Open the Print dialog box.
2. Select **Printer Settings** from the drop-down list, and select **Basic Settings** tab.

3. Click **Security Print**.

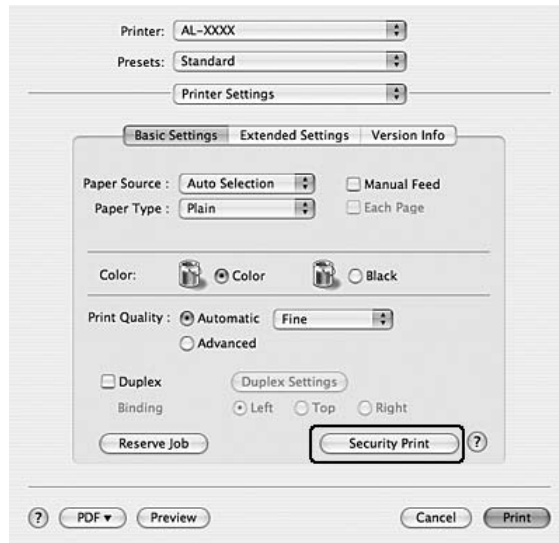

4. Select the **Print Hidden Watermark** check box.
5. Select **Copy** from the drop-down list, and then select Color to print anti-copy pattern.
6. Select the position where the anti-copy pattern is printed. If you select **Front**, “COPY” is printed on the text and images. If you select **Back**, “COPY” is printed on the text but not on the images in the document. If you select **Only Blank**, “COPY” is printed on blank areas in the images as well as on the text.
7. Click **OK**.

---

## Printing Web Pages to Fit Your Paper Size

This function allows you to make Web pages fit to your paper size when printing. Install EPSON Web-To-Page from the printer software CD-ROM.

**Note:**

*This software is not available for Windows Vista, XP x64, and Mac OS X.*

After you install EPSON Web-To-Page, the menu bar is displayed on the Microsoft Internet Explorer Toolbar. If it does not appear, select **Toolbars** from the View menu of Internet Explorer, and then select **EPSON Web-To-Page**.

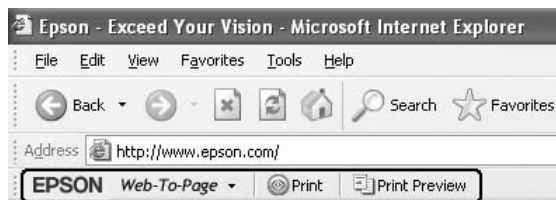

## Using the Reserve Job Function

This function allows you to store print jobs on the printer's memory and to print them later directly from the printer's control panel. You can prevent the printed document from being looked at by other people by applying a password to the print job.

This function uses the following types of printer memory.

Printer's Storage	Description
CompactFlash	The optional CompactFlash memory must be installed on your printer in order to use the Reserve Job function. Make sure that the CompactFlash memory is correctly recognized by the printer driver before you start using the Reserve Job function.
RAM Disk	You need to keep sufficient RAM disk capacity in order to use the Reserve Job function. To enable the RAM disk, you have to set the RAM Disk setting on the control panel to Normal or Maximum. For instructions about increasing your printer's memory, see "Installing a memory module" on page 150. After the memory module is installed, you must update the option information. See "Making Optional Settings" on page 217. When both CompactFlash memory and a RAM disk are installed, CompactFlash memory is given priority and makes the RAM disk unavailable.

The table below gives an overview of the Reserve Job options.

Reserve Job Option	Description
Re-Print Job	Lets you print the job now and store it on the printer's memory. You can print the same job several times.
Verify Job	Lets you print one copy now to verify the content. You can print multiple copies later.
Stored Job *	Lets you store the print job on the printer's memory without printing it now.

Reserve Job Option	Description
Confidential Job	Lets you apply a password to the print job. You can print the job entering the password on the printer's control panel.

\* Not available when you use the RAM disk for the printer's memory.

## Sending the print job

### For Windows users

1. Click the **Optional Settings** tab, then click **Reserve Jobs Settings**. The Reserve Jobs Settings dialog box appears.
2. Select the **Reserve Job On** check box, then select **Re-Print Job, Verify Job, Stored Job, or Confidential Job**.
3. Enter a user name and job name in the corresponding text boxes. If you selected **Confidential Job**, enter a four-digit number in the password text box to set the password.

**Note:**

*If you want to create a thumbnail of the first page of a job, select the **Create a thumbnail** check box. Thumbnails can be accessed by entering `http://` followed by the internal print server's IP address in a Web browser.*

4. Click **OK**.

**Note:**

*The **OK** button becomes available after both the user name and job name have been entered.*

If you selected **Re-print Job**, the printer prints your document. If you selected **Verify Job**, the printer prints one copy of your document.

To print or delete this data using the printer's control panel, see "Printing and Deleting Reserve Job Data" on page 119.

### For Macintosh users

1. Open the Print dialog box and select **Printer Settings** from the drop-down list, then click the **ReserveJob** button (for Mac OS X 10.5) or **Basic Settings** tab (for Mac OS X 10.4 or below).
2. For Mac OS X 10.4 or below, click the **Reserve Job** button.

3. Select the **Reserve Job On** check box, then select **Re-Print Job**, **Verify Job**, **Stored Job**, or **Confidential Job**.
4. Enter a user name and job name in the corresponding text boxes. If you selected **Confidential Job**, enter a four-digit number in the password text box to set the password.

**Note:**

*If you want to create a thumbnail of the first page of a job, select the **Create a thumbnail** check box.*

*Thumbnails can be accessed by entering <http://> followed by the internal print server's IP address in a Web browser.*

5. For Mac OS X 10.4 or below, click **OK**.

**Note:**

*The **OK** button becomes available after both the user name and job name have been entered.*

If you selected **Re-print Job**, the printer prints your document. If you selected **Verify Job**, the printer prints one copy of your document.

To print or delete this data using the printer's control panel, see "Printing and Deleting Reserve Job Data" on page 119.

## Chapter 3

# Using the Control Panel

## Using the Control Panel Menus

### When to make control panel settings

In general, printer driver settings override settings made using the control panel. You should make the following settings by using the control panel because these settings cannot be made in the printer driver.

- Settings to select emulation modes and IES (Intelligent Emulation Switching) mode
- Settings to specify a channel and configure the interface
- Settings to specify the size of the memory buffer used to receive data

### How to access the control panel menus

1. Press the ► **Enter** button to access the control panel menus.

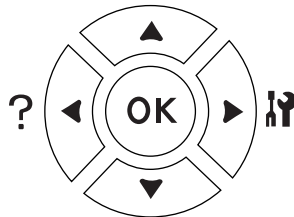

2. Use the ▲ **Up** and ▼ **Down** buttons to scroll through the menus.
3. Press the ► **Enter** button to view the items in a menu. Depending on the menu, the LCD panel displays an item and the current setting separated (◆ YYY Y=ZZZZ), or only an item (◆ YYY Y).
4. Use the ▲ **Up** and ▼ **Down** buttons to scroll through the items, or press the ◀ **Back** button to return to the previous level.

5. Press the ► **Enter** button to carry out the operation indicated by an item, such as printing a configuration status sheet or resetting the printer, or to view the settings available for an item, such as paper sizes or emulation modes.

Use the ▲ **Up** and ▼ **Down** buttons to scroll through available settings, then press the ► **Enter** button to select a setting and return to the previous level. Press the ◀ **Back** button to return to the previous level without changing the setting.

**Note:**

❑ *You need to turn the printer off and then on to activate some settings. For details, see “Control Panel Menus” on page 81.*

❑ *The **OK** button can be used instead of the ► **Enter** button in step 3 or 5.*

6. Press the **Start/Stop** button to exit the control panel menus.

## How to register menus as bookmarks

By registering bookmarks for frequently used menus, you can display the registered menus by just pressing the **OK** button while the LCD panel displays `Ready` or `Sleep`.

**Note:**

*The maximum number of menus you can register as bookmarks is 3.*

1. Display the menu to register. For details, see “How to access the control panel menus” on page 79.
2. Press the **OK** button for more than two seconds.

The `Add Bookmark` menu appears.

**Note:**

*Some menus cannot be bookmarked. If you tried to register them, `Bookmark Failed` is displayed.*

3. Press the ▲ **Up** and ▼ **Down** buttons to select the menu to delete, then press the ► **Enter** button.

**Note:**

*To register a new menu, you have to delete one of the registered menus from the bookmark.*

If `Bookmark Registered` is displayed, the menu is bookmarked successfully.



**Note:**

To delete the bookmarked menus, select **Reset All** from the control panel's **Reset Menu**.

---

## Control Panel Menus

**Note:**

Some menus and items appear only when a corresponding optional device is installed or an appropriate setting has been done.

## Information Menu

Press the **▼ Down** or **▲ Up** button to select an item. Press the **► Enter** button to print a sheet or font sample.

Item	Values
Print Configuration Status Sheet	-
Print Supplies Status Sheet	-
Print Usage History Sheet	-
Reserve Job List* <sup>1</sup>	-
Form Overlay List* <sup>2</sup>	-
Network Status Sheet* <sup>3</sup>	-
AUX Status Sheet* <sup>4</sup>	-
USB Ext I/F Status Sht* <sup>5</sup>	-
PS3 Status Sheet	-
PS3 Font List	-
ROM A Information	-
PCL Font Sample	-
ESCP2 Font Sample	-
FX Font Sample	-
I239X Font Sample	-

Item	Values
Cyan(C)/Magenta(M)/Yellow(Y)/Black(K) Toner	E*****F to E F
Cyan(C)/Magenta(M)/Yellow(Y)/Black(K) Photocon	E*****F to E F
Transfer Unit Life	E*****F to E F
Fuser Unit Life	E*****F to E F
Total Pages	0 to 99999999
Color Pages	0 to 99999999
B/W Pages	0 to 99999999

\*1 Available only when the jobs are stored by using the Quick Print Job feature.

\*2 This item appears only when Form Overlay data exists.

\*3 Available only when the Network I/F setting in Network Menu is set to On.

\*4 Available only when an optional interface card is installed.

\*5 Available only when the printer is connected to a USB device with D4 support and has been turned on when the USB I/F setting is set to On.

### Print Configuration Status Sheet

Prints a sheet showing the current printer settings and installed options. This sheet can be useful to confirm whether option have been installed correctly.

### Print Supplies Status Sheet

Prints a sheet showing information about consumables.

### Print Usage History Sheet

Prints a sheet showing the history of the printer's usage.

### Reserve Job List

Prints a list of reserved print jobs stored on the printer's memory.

### Form Overlay List

Prints a list of the form overlays stored in the optional CompactFlash memory.

### Network Status Sheet

Prints a sheet showing the working status of the network.

### **AUX Status Sheet**

Prints a sheet showing the working status of the optional interface.

### **USB Ext I/F Status Sht**

Prints a sheet showing the working status of the USB interface.

### **PS3 Status Sheet**

Prints a sheet showing information about the PS3 mode such as the PS3 version.

### **PS3 Font List, PCL Font Sample, ESCP2 Font Sample, FX Font Sample, I239X Font Sample**

Prints a sample of the fonts available for your selected printer emulation.

### **ROM A Information**

Prints a sheet showing information about the memory installed in the ROM A slot.

### **Cyan(C) Toner/Magenta(M) Toner/Yellow(Y) Toner/Black(K) Toner/ Cyan(C) Photocon/ Magenta(M) Photocon/Yellow(Y) Photocon/Black(K) Photocon/ Transfer Unit Life/Fuser Unit Life**

The number of asterisks (\*) between “E” and “F” indicates the remaining service lives of consumables. If a non-genuine consumable is used, “?” is displayed instead of the indicator.

### **Total Pages**

Displays the total number of pages printed by the printer.

### **Color Pages**

Displays the total number of pages printed in color by the printer.

### **B/W Page**

Displays the total number of pages printed in black-and-white by the printer.

## System Information Menu

The following information is displayed.

- Main Version
- MCU Version
- Serial No
- Memory
- MAC Address

## Tray Menu

Item	Settings (default in bold)
MP Tray Size	<b>A4</b> , A3, A5, B4, B5, LT, HLT, LGL, GLT, GLG, B, EXE, F4, MON, C10, DL, C5, C6, IB5, A3F
Cassette1 Size	A4, A3, A5, B4, B5, A3F
Cassette2 Size* / Cassette3 Size* / Cassette4 Size*	A4, A3, B4, B5, LT, LGL, B, F4
MP Type	<b>Plain</b> , SemiThk, Preprinted, Letterhead, Recycled, Color, Trnsprncy, Labels
Cassette1 Type/ Cassette2 Type* / Cassette3 Type* / Cassette4 Type*	<b>Plain</b> , SemiThk, Preprinted, Letterhead, Recycled, Color

\* Available only when the optional paper cassette unit is installed.

### MP Tray Size

Select your paper size from this menu.

### Cassette 1 Size/Cassette 2 Size/Cassette 3 Size/Cassette 4 Size

Displays the paper size loaded in the standard and optional paper cassettes.

### MP Type

Lets you set the paper type loaded in the MP tray.

## Cassette 1 Type/Cassette 2 Type/Cassette 3 Type/Cassette 4 Type

Lets you select the paper type loaded in the standard and optional paper cassettes.

## Emulation Menu

### Note:

You can specify different emulations for each interfaces.

Item	Settings (default in bold)
Parallel	<b>Auto</b> , ESCP2, FX, I239X, PS3, PCL
USB	<b>Auto</b> , ESCP2, FX, I239X, PS3, PCL
Network	<b>Auto</b> , ESCP2, FX, I239X, PS3, PCL
AUX*	<b>Auto</b> , ESCP2, FX, I239X, PS3, PCL

\* Available only when an optional Type-B interface card is installed.

## Printing Menu

### Note:

The settings are overridden by the settings made in the printer driver.

Item	Settings (default in bold)
Page Size	<b>A4</b> , A3, A5, B4, B5, LT, HLT, LGL, GLT, GLG, B, EXE, F4, MON, C10, DL, C5, C6, IB5, A3F, CTM* <sup>1</sup>
Wide A4	<b>Off</b> , On
Orientation	<b>Port</b> , Land
Resolution	300, <b>600</b>
RItech	<b>On</b> , Off
Toner Save	<b>Off</b> , On
Top Offset	-150.0 ... <b>0.0</b> ... 150.0 mm in 0.5 increments
LeftOffset	-150.0 ... <b>0.0</b> ... 150.0 mm in 0.5 increments
T Offset B* <sup>2</sup>	-150.0 ... <b>0.0</b> ... 150.0 mm in 0.5 increments

Item	Settings (default in bold)
L Offset B* <sup>2</sup>	-150.0 ... <b>0.0</b> ... 150.0 mm in 0.5 increments

\*<sup>1</sup> Custom-size paper is 90.0 × 139.7 mm at the minimum and 311.2 × 1200.0 mm at the maximum.

\*<sup>2</sup> Available only when the optional Duplex Unit is installed.

## Page Size

Specifies the paper size.

### Wide A4

Selecting  decreases the left and right margins from 4 mm to 3.4 mm.

## Orientation

Specifies whether the page is printed in portrait or landscape orientation.

## Resolution

Specifies the printing resolution.

## RITech

Turning RITech on produces smoother and crisper lines, text, and graphics.

## Toner Save

When this setting is selected, the printer saves toner by substituting a gray shade for the black inside of characters. The characters are outlined in full black on the right and lower edges.

## Top Offset

Makes fine adjustments to the vertical printing position of the page.



### **Caution:**

*Make sure that the printed image does not extend beyond the edge of the paper. Otherwise, you may damage the printer.*

## LeftOffset

Makes fine adjustments to the horizontal printing position of the page. This is useful for fine adjustments.



**Caution:**

*Make sure that the printed image does not extend beyond the edge of the paper. Otherwise, you may damage the printer.*

### T Offset B

Adjusts the vertical printing position on the back of the paper when printing on both sides. Use this if the printout on the back is not where you expected.

### L Offset B

Adjusts the horizontal printing position on the back of the paper when printing on both sides. Use this if the printout on the back is not where you expected.

## Setup Menu

Item	Settings (default in bold)
Language	<b>English</b> , Français, Deutsch, Italiano, ESPAÑOL, SVENSKA, Dansk, Nederlands, SUOMI, Português, Norsk, CATALÀ, РУССКИЙ, 中文, 繁體中文, 한국어
Time to Sleep	5, 15, <b>30</b> , 60, 120, 180, 240 Min
Time Out	0, 5 to <b>60</b> to 300 in increments of 1
Paper Source	<b>Auto</b> , MP, Cassette 1, Cassette 2*1, Cassette 3*1, Cassette 4*1
MP Mode	<b>Normal</b> , Last
Manual Feed	<b>Off</b> , 1st Page, EachPage
Copies	<b>1</b> to 999
Duplex*1*2	<b>Off</b> , On
Binding*1*2	<b>Long Edge</b> , Short Edge
Start Page*1*2	<b>Front</b> , Back
Paper Type	<b>Normal</b> , Thick, ExtraThk, SuperThk, Transparency, Coated
Page Side	<b>Front</b> , Back

Item	Settings (default in bold)
Skip Blank Page <sup>*3</sup>	<b>Off</b> , On
Auto Eject Page <sup>*4</sup>	<b>Off</b> , On
Size Ignore	<b>Off</b> , On
Auto Cont	<b>Off</b> , On
Page Protect <sup>*3</sup>	<b>Auto</b> , On
LCD Contrast	0 to <b>7</b> to 15
RAM Disk <sup>*1*5</sup>	<b>Off</b> , Normal, Maximum

\*1 Available only when the corresponding option is installed.

\*2 Available only when you use A4, A3, A5, B4, B5, LT, LGL, GLT, GLG, B, EXE, F4, or A3F size paper.

\*3 Available only for ESC/Page, ESC/P2, FX, or I239X mode.

\*4 Not available in PS3 and PCL.

\*5 After this item is changed, the setting value takes effect after a warm boot or after the power is turned on again.

## Language

Specifies the language displayed on the LCD panel and that printed on the status sheet.

## Time to Sleep

Specifies the length of time until the printer enters the sleep mode if there are no button operations.

## Time Out

Specifies the length of the time, in seconds, before a time out when interfaces are being switched automatically. The time before a time out occurs is the length of time from the point when no data is being received from an interface until the point of switching the interface. If the printer has a print job when switching the interface, the printer prints the print job.

## Paper Source

Specifies whether paper feeds into the printer from the MP tray, the standard paper cassette, or the optional paper cassette unit.

If you select **Auto**, paper feeds from the paper source containing paper that matches your Paper Size setting.



## MP Mode

This setting determines whether the MP tray has the highest or lowest priority when **Auto** is selected as the Paper Source setting in the printer driver. When **Normal** is selected as the MP Mode, the MP tray has the highest priority as the paper source. If you select **Last**, the MP tray has the lowest priority.

## Manual Feed

Allows you to select the manual feed mode for the MP tray.

## Copies

Designates the number of copies to be printed, from 1 through 999.

## Duplex

Turns duplex printing on or off. This allows you to print on both sides of a page.

## Binding

Specifies the binding direction of the printout.

## Start Page

Specifies whether printing starts from the front or back of the page.

## Paper Type

Specifies the type of paper to be used for printing. The printer adjusts the printing speed according to this setting. The printing speed is reduced when **Thick**, **ExtraThk**, **SuperThk**, or **Transparency** is selected.

## Page Side

Select **Front** when printing on the front of normal paper (Normal), thick paper (Thick), extra thick paper (Extra Thick), super thick paper (Super Thick), or coated paper (Coated). Select **Back** when printing on the back of normal paper (Normal (Back)), thick paper (Thick (Back)), extra thick paper (Extra Thick (Back)), super thick paper (Super Thick (Back)), or coated paper (Coated (Back)).

## Skip Blank Page

Enables you to skip blank pages when printing. This setting is available when you print in the ESC/Page, ESCP2, FX, or I239X mode.

### Auto Eject Page

Specifies whether or not to eject paper when the limit specified in the Time Out setting is reached. The default is `Off`, which means paper is not ejected when the time-out limit is reached.

### Size Ignore

If you want to ignore a paper size error, select `On`. When you turn this item on, the printer keeps printing even if the image size exceeds the printable area for the specified paper size. This may cause smudges because of the toner that is not transferred onto the paper properly. When this item is turned off, the printer stops printing if a paper size error occurs.

### Auto Cont

When you turn this setting on, the printer automatically continues printing after a certain period of time when one of the following errors occurs: Paper Set, Print Overrun, or Mem Overflow. When this option is off, you must press the **Start/Stop** button to resume printing.

### Page Protect

Allocates additional printer memory for printing data, as opposed to receiving it. You may need to turn this setting on if you are printing a very complex page. If a `Print Overrun` error message appears on the LCD panel during printing, turn this setting on and reprint your data. This reduces the amount of memory reserved for processing data so your computer may take longer to send the print job, but it will allow you to print complex jobs. Page Protect usually works best when `Auto` is selected. You will need to increase your printer's memory if memory errors continue to occur.

#### **Note:**

*Changing the Page Protect setting reconfigures the printer's memory, which causes any downloaded fonts to be deleted.*

### LCD Contrast

Adjusts the contrast of the LCD panel. Use the **▲ Up** and **▼ Down** buttons to set the contrast between `0` (lowest contrast) and `15` (highest contrast.)

### RAM Disk

Specifies the RAM disk size available for the Reserve Job function. See the table below for details.

Optional RAM capacity (Total RAM capacity)	RAM Disk setting		
	Off	Normal	Maximum
0 MB (Total 256 MB)	Disabled	16 MB	16 MB
128 MB (Total 384 MB)		n/2 MB (n=Optional RAM capacity)	128 MB
256 MB (Total 512 MB)			256 MB
512 MB (Total 768 MB)			512 MB

## Reset Menu

### Clear Warning

Clears warning messages that show errors except for these that occur from consumable products or mandatory-replacement parts.

### Clear All Warnings

Clears all warning messages that appear on the LCD panel.

### Reset

Stops printing and clears the current job received from the active interface. You may want to reset the printer when there is a problem with the print job itself and the printer cannot print successfully.

### Reset All

Stops printing, clears the printer memory, and restores the printer settings to their default values. The print jobs received from all interfaces are erased.

#### **Note:**

*Performing Reset All clears print jobs received from all interfaces. Be careful not to interrupt someone else's job.*

### SelecType Init

Restores the control panel menu settings to their default values.

## Quick Print Job Menu

This menu allows you to print or delete print jobs that were stored in the printer's memory using the Quick Print Job feature (Re-Print Job, Verify Job, Stored Job) of the printer driver's Reserve Job function. For instructions on using this menu, see "Using the Quick Print Job Menu" on page 120.

## Confidential Job Menu

This menu allows you to print or delete print jobs stored in the printer's memory using the Confidential Job feature of the printer driver's Reserve Job function. You need to enter the correct password to access this data. For instructions on using this menu, see "Using the Confidential Job Menu" on page 120.

## Clock Menu

Item	Settings (default in bold)
Local Time Diff.	-13:59 ... <b>0:00</b> ...+13:59
Time Setting	2000/ 01/01 00:00 to 2099/12/31 23:59
Date Format	<b>DD/MM/YY</b> , MM/DD/YY, YY/MM/DD

### Local Time Diff.

Specifies the current date and time by entering the time difference from Greenwich Mean time.

### Time Setting

Specifies the current date and time by entering them directly.

### Date Format

Specifies the format to display the date.

## Parallel Menu

These settings control communication between the printer and the computer when using the parallel interface.

Item	Settings (default in bold)
Parallel I/F*	<b>On</b> , Off
Speed*	<b>Fast</b> , Normal
Bi-D*	<b>ECP</b> , Off, Nibble
Buffer Size*	<b>Normal</b> , Maximum, Minimum

\* After this item is changed, the setting value takes effect after a warm boot or after the power is turned on again. While it is reflected in the Status Sheet and EJM read-back, the actual change takes effect after a warm boot or after the power is turned on again.

### Parallel I/F

Allows you to activate or deactivate the parallel interface.

### Speed

Specifies the pulse width of the ACKNLG signal when receiving data in the Compatibility mode or Nibble mode. When **Fast** is selected, the pulse width is about 1  $\mu$ s. When **Normal** is selected, the pulse width is about 10  $\mu$ s.

### Bi-D

Allows you to specify the bidirectional communication mode. When you select **Off**, bidirectional communication is disabled.

### Buffer Size

Determines the amount of memory to be used for receiving data and printing data. If **Maximum** is selected, more memory is allocated for receiving data. If **Minimum** is selected, more memory is allocated for printing data.

#### Note:

- To activate Buffer Size settings, you must turn off the printer for more than five seconds then turn it back on. Or, you can perform a **Reset All** operation, as explained in "Reset Menu" on page 91.
- Resetting the printer erases all print jobs. Make sure the Ready light is not flashing when you reset the printer.

## USB Menu

Item	Settings (default in bold)
USB I/F <sup>*1</sup>	<b>On</b> , Off
USB Speed <sup>*1 *2</sup>	<b>HS</b> , FS
Get IP Address <sup>*2 *3</sup>	Auto, PING, Panel
IP <sup>*2 *3 *4 *5</sup>	0.0.0.1 to 255.255.255.254
SM <sup>*2 *3</sup>	0.0.0.0 to 255.255.255.255
GW <sup>*2 *3</sup>	0.0.0.0 to 255.255.255.255
NetWare <sup>*2 *3</sup>	On, Off
AppleTalk <sup>*2 *3</sup>	On, Off
MS Network <sup>*2 *3</sup>	On, Off
Bonjour <sup>*2 *3</sup>	On, Off
USB Ext I/F Init <sup>*2 *3</sup>	-
Buffer Size <sup>*1 *2</sup>	<b>Normal</b> , Maximum, Minimum

<sup>\*1</sup> After this item is changed, the setting value takes effect after a warm boot or after the power is turned on again. While it is reflected in the Status Sheet and EJM read-back, the actual change takes effect after a warm boot or after the power is turned on again.

<sup>\*2</sup> Available only when USB I/F is set to On.

<sup>\*3</sup> Available only when a USB external device with D4 support is connected. The contents of the settings depend on the USB external device settings.

<sup>\*4</sup> If the Get IP Address setting is set to Auto, this setting cannot be changed.

<sup>\*5</sup> When the Get IP Address setting is changed from Panel or PING to Auto, the panel setting values are saved. Then Auto is changed back to Panel or PING, the saved setting values are displayed. The value is set to 192.168.192.168 if the settings are not made from the panel.

### USB I/F

Allows you to activate or deactivate the USB interface.

### USB Speed

Allows you to select the operation mode of USB interface. Selecting HS is recommended. Select FS if HS does not work on your computer system.

## Buffer Size

Determines the amount of memory to be used for receiving data and printing data. If **Maximum** is selected, more memory is allocated for receiving data. If **Minimum** is selected, more memory is allocated for printing data.

### Note:

- To activate **Buffer Size** settings, you must turn off the printer for more than five seconds then turn it back on. Or, you can perform a **Reset All** operation, as explained in “Reset Menu” on page 91.
- Resetting the printer erases all print jobs. Make sure the **Ready** light is not flashing when you reset the printer.

## Network Menu

See the *Network Guide* for each setting.

## AUX Menu

See the *Network Guide* for each setting.

## PCL Menu

These settings are available in the PCL mode.

Item	Settings (default in bold)
FontSource	<b>Resident</b> , Download* <sup>1</sup>
Font Number	<b>0</b> ... 65535 (depending on your settings)
Pitch* <sup>2</sup>	0.44 ... <b>10.00</b> ... 99.99 cpi in 0.01 cpi increment
Height* <sup>2</sup>	4.00 ... <b>12.00</b> ... 999.75 pt in 0.25 pt increment
SymSet	<b>IBM-US</b> , Roman-8, Roman-9, ECM94-1, 8859-2 ISO, 8859-9 ISO, 8859-10ISO, 8859-15ISO, PcBlt775, IBM-DN, PcMultiling, PcE.Europe, PcTk437, PcEur858, Pc1004, WiAnsi, WiE.Europe, WiTurkish, WiBALT, DeskTop, PsText, VeInternati, VeUS, MsPublishin, Math-8, PsMath, VeMath, PiFont, Legal, UK, ANSI ASCII, Swedis2, Italian, Spanish, German, Norweg1, French2, Windows, McText, Hebrew7, 8859-8 ISO, Hebrew8, Arabic8, OCR A, OCR B, Pc866Cyr, Pc866Ukr, WinCyr, ISOCyr, Pc8Grk, Pc851Grk, WinGrk, ISOGrk, Greek8, Pc862Heb, Pc864Ara, HPWARA

Item	Settings (default in bold)
Form	5 ... <b>64</b> ... 128 lines
CR Function	<b>CR</b> , CR+LF
LF Function	<b>LF</b> , CR+LF
Tray Assign	<b>4K</b> , 5S, 4

\*1 Available only when downloaded fonts are available.

\*2 Depending on the font that has been selected.

### FontSource

Sets the default font source.

### Font Number

Sets the default font number for the default font source. The available number depends on the settings you made.

### Pitch

Specifies the default font pitch if the font is scalable and of fixed-pitch. You can select from 0 .44 to 99 .99 cpi (characters per inch), in 0.01-cpi increments. This item may not appear depending on the Font Source or Font Number settings.

### Height

Specifies the default font height if the font is scalable and proportional. You can select from 4 .00 to 999 .75 points, in 0.25-point increments. This item may not appear depending on the Font Source or Font Number settings.

### SymSet

Selects the default symbol set. If the font you selected in Font Source and Font Number is not available in the new SymSet setting, the Font Source and the Font Number settings are automatically replaced with the default value, IBM-US.

### Form



Selects the number of lines for the selected paper size and orientation. This also causes a line spacing (VMI) change, and the new VMI value is stored in the printer. This means that later changes in the Page Size or Orientation settings cause changes in the Form value, based on the stored VMI.

### CR Function, LF Function

These functions are included for users of particular operating systems, such as UNIX.

### Tray Assign

Changes the assignment for the paper source select command. When 4 is selected, the commands are set as compatible with the HP LaserJet 4. When 4K is selected, the commands are set as compatible with the HP LaserJet 4000, 5000, and 8000. When 5S is selected, the commands are set as compatible with the HP LaserJet 5S.

## PS3 Menu

Item	Settings (default in bold)
Error Sheet	<b>Off</b> , On
Coloration	<b>Color</b> , Mono
Image Protect	<b>Off</b> , On
Binary	<b>Off</b> , On
Text Detection	<b>Off</b> , On
PDF Page Size	Auto, <b>A4</b> , A3, A5, B4, B5, LT, HLT, LGL, GLT, GLG, B, EXE, F4, MON, C10, DL, C5, C6, IB5, A3F

### Error Sheet

When you select **On**, the printer prints out an error sheet when an error occurs in the PS3 mode or when the PDF file you tried to print is not a supported version.

### Coloration

Allows you to select the color printing or black-and-white printing mode.

### Image Protect

When **On** is selected, the print quality is not reduced even with insufficient memory. In that case, **Memory Overflow** is displayed and the printing is stopped.

When **Off** is selected, the print quality is reduced with insufficient memory. In that case, **Image Optimum** is displayed and the printing is continued.

## Binary

Specifies the data format. Select **On** for the Binary data and select **Off** for the ASCII data.

### Note:

- Binary can only be used with network connection.*
- You do not have to select **On** when using AppleTalk.*

To use the Binary data, make sure your application supports Binary data and that **SEND CTRL-D Before Each Job** and **SEND CTRL-D After Each Job** are set to **No**.

When this setting is set to **On**, you cannot use TBCP (Tagged binary communication protocol) in the printer driver settings.

## Text Detection

When you select **On**, the text file is converted to a PostScript file when printing. This setting is available only when you select **PS3** in the **Emulation Menu**.

## PDF Page Size

Specifies the paper size when you send the PDF file directory from a computer or some other device. If **Auto** is selected, the paper size is determined based on the size of the first page that is printed.

## ESCP2 Menu

Item	Settings (default in bold)
Font	<b>Courier</b> , Prestige, Roman, Sans serif, Roman T, Orator S, Sans H, Script, OCR A, OCR B
Pitch	<b>10</b> , 12, 15 cpi, Prop.
Condensed	<b>Off</b> , On
T. Margin	0.40 ... <b>0.50</b> ... 1.50 inches in 0.05-inch increments
Text	1... <b>66</b> ... 132 lines

Item	Settings (default in bold)
CGTable	<b>PcUSA</b> , Italic, PcMultilin, PcPortugue, PcCanFrenc, PcNordic, PcTurkish2, Pclcelandic, PcE.Europe, BpBRASCI, BpAbicom, Roman-8, PcEur858, ISO Latin1, 8859-15ISO, PcSI437, PcTurkish1, 8859-9ISO, Mazowia, CodeMJK, PcGk437, PcGk851, PcGk869, 8859-7ISO, PcCy855, PcCy866, PcUkr866, PcLit771, Bulgarian, Hebrew7, Hebrew8, PcHe862, PcAr864, PcAr864Ara, PcAr720, PcLit774, Estonia, ISO Latin2, PcLat866
Country	<b>USA</b> , France, Germany, UK, Denmark, Sweden, Italy, Spain1, Japan, Norway, Denmark2, Spain2, LatinAmeric, Korea, Legal
Auto CR	<b>On</b> , Off
Auto LF	<b>Off</b> , On
Bit Image	<b>Dark</b> , Light, BarCode
ZeroChar	<b>0</b> , (or the zero character with a slash)

## Font

Selects the font.

## Pitch

Selects the pitch (the horizontal spacing) of the font in fixed pitch, measured in cpi (characters per inch). You can also choose proportional spacing.

## Condensed

Turns condensed printing on or off.

## T. Margin

Sets the distance from the top of the page to the baseline of the first printable line. The distance is measured in inches. The smaller the value, the closer the printable line is to the top.

## Text

Sets the page length in lines. For this option, a line is assumed to be 1 pica (1/6 inch). If you change the Orientation, Page Size, or T. Margin settings, the page length setting automatically returns to the default for each paper size.

## CG Table

Use the character generator (CG) table option to select the graphics character table or the italics table. The graphics table contains graphic characters for printing lines, corners, shaded areas, international characters, Greek characters, and mathematical symbols. If you select *Italic*, the upper half of the character table is defined as italic characters.

### Country

Use this option to select one of the fifteen international symbol sets. See the *Font Guide* for samples of the characters in each country's symbol set.

### Auto CR

Specifies whether the printer performs a carriage-return/line-feed (CR-LF) operation whenever the printing position goes beyond the right margin. If you select *Off*, the printer does not print any characters beyond the right margin and does not perform any line wrapping until it receives a carriage-return character. This function is handled automatically by most applications.

### Auto LF

If you select *Off*, the printer does not send an automatic line-feed (LF) command with each carriage-return (CR). If *On* is selected, a line-feed command is sent with each carriage-return. Select *On* if your text lines overlap.

### Bit Image

The printer is able to emulate the graphics densities set with the printer commands. If you select *Dark*, the bit image density is high, and if you select *Light*, the bit image density is low.

If you select *BarCode*, the printer converts bit images to bar codes by automatically filling in any vertical gaps between dots. This produces unbroken vertical lines that can be read by a bar code reader. This mode will reduce the size of the image being printed, and may also cause some distortion when printing bit image graphics.

### ZeroChar

Specifies whether the printer prints a slashed or unslashed zero.

## FX Menu

Item	Settings (default in bold)
Font	<b>Courier</b> , Prestige, Roman, Sans serif, Script, Orator S, OCR A, OCR B

Item	Settings (default in bold)
Pitch	<b>10</b> , 12, 15 cpi, Prop.
Condensed	<b>Off</b> , On
T. Margin	0.40 ... <b>0.50</b> ... 1.50 inches in 0.05-inch increments
Text	1... <b>66</b> ... 132 lines
CGTable	<b>PcUSA</b> , Italic, PcMultilin, PcPortugue, PcCanFrenc, PcNordic, PcTurkish2, Pclcelandic, PcE.Europe, BpBRASCIi, BpAbicomp, Roman-8, PcEur858, ISO Latin1, 8859-15ISO
Country	<b>USA</b> , France, Germany, UK, Denmark, Sweden, Italy, Spain1, Japan, Norway, Denmark2, Spain2, LatinAmeric
Auto CR	<b>On</b> , Off
Auto LF	<b>Off</b> , On
Bit Image	<b>Dark</b> , Light, BarCode
ZeroChar	<b>0</b> , (or the zero character with a slash)

## Font

Selects the font.

## Pitch

Selects the pitch (the horizontal spacing) of the font in fixed pitch, measured in cpi (characters per inch). You can also choose proportional spacing.

## Condensed

Turns condensed printing on or off.

## T. Margin

Sets the distance from the top of the page to the baseline of the first printable line. The distance is measured in inches. The smaller the value, the closer the printable line is to the top.

## Text

Sets the page length in lines. For this option, a line is assumed to be 1 pica (1/6 inch). If you change the Orientation, Page Size, or T. Margin settings, the page length setting automatically returns to the default for each paper size.

## CG Table

Use the character generator (CG) table option to select the graphics character table or the italics table. The graphics table contains graphic characters for printing lines, corners, shaded areas, international characters, Greek characters, and mathematical symbols. If you select *Italic*, the upper half of the character table is defined as italic characters.

## Country

Use this option to select one of the thirteen international symbol sets. See the *Font Guide* for samples of the characters in each country's symbol set.

## Auto CR

Specifies whether the printer performs a carriage-return/line-feed (CR-LF) operation whenever the printing position goes beyond the right margin. If you select *Off*, the printer does not print any characters beyond the right margin and does not perform any line wrapping until it receives a carriage-return character. This function is handled automatically by most applications.

## Auto LF

If you select *Off*, the printer does not send an automatic line-feed (LF) command with each carriage-return (CR). If *On* is selected, a line-feed command is sent with each carriage-return. Select *On* if your text lines overlap.

## Bit Image

The printer is able to emulate the graphics densities set with the printer commands. If you select *Dark*, the bit image density is high, and if you select *Light*, the bit image density is low.

If you select *BarCode*, the printer converts bit images to bar codes by automatically filling in any vertical gaps between dots. This produces unbroken vertical lines that can be read by a bar code reader. This mode will reduce the size of the image being printed, and may also cause some distortion when printing bit image graphics.

## ZeroChar

Selects whether the printer prints a slashed or unslashed zero.

## I239X Menu

The I239X mode emulates IBM® 2390/2391 Plus commands.

These settings are available only when the printer is in the I239X mode.

Item	Settings (default in bold)
Font	<b>Courier</b> , Prestige, Gothic, Orator, Script, Presentor, Sans serif
Pitch	<b>10</b> , 12, 15, 17, 20, 24 cpi, Prop.
Code Page	<b>437</b> , 850, 858, 860, 863, 865
T. Margin	0.30 ... <b>0.40</b> ...1.50 inches in 0.05-inch increments
Text	1 ... <b>67</b> ... 132 lines
Auto CR	<b>Off</b> , On
Auto LF	<b>Off</b> , On
Alt. Graphics	<b>Off</b> , On
Bit Image	<b>Dark</b> , Light
ZeroChar	<b>0</b> , (or the zero character with a slash)
CharacterSet	1, <b>2</b>

### Font

Selects the font.

### Pitch

Selects the pitch (the horizontal spacing) of the font in fixed pitch, measured in cpi (characters per inch). You can also choose proportional spacing.

### Code Page

Selects the character tables. Character tables contain the characters and symbols used by different languages. The printer prints text based on the selected character table.

### T. Margin

Sets the distance from the top of the page to the baseline of the first printable line. The distance is measured in inches. The smaller the value, the closer the printable line is to the top.

### Text

Sets the page length in lines. For this option, a line is assumed to be 1 pica (1/6 inch). If you change the Orientation, Page Size, or T. Margin settings, the page length setting automatically returns to the default for each paper size.

**Auto CR**

Specifies whether the printer performs a carriage-return/line-feed (CR-LF) operation whenever the printing position goes beyond the right margin. If this setting is off, the printer does not print any characters beyond the right margin and does not perform any line wrapping until it receives a carriage-return character. This function is handled automatically by most applications.

**Auto LF**

If you select **Off**, the printer does not send an automatic line-feed (LF) command with each carriage-return (CR). If **On** is selected, a line-feed command is sent with each carriage-return. Select **On** if your text lines overlap.

**Alt.Graphics**

Turns the Alternate Graphics option on or off.

**Bit Image**

The printer is able to emulate the graphics densities set with the printer commands. If you select **Dark**, the bit image density is high, and if you select **Light**, the bit image density is low.

If you select **BarCode**, the printer converts bit images to bar codes by automatically filling in any vertical gaps between dots. This produces unbroken vertical lines that can be read by a bar code reader. This mode will reduce the size of the image being printed, and may also cause some distortion when printing bit image graphics.

**ZeroChar**

Selects whether the printer prints a slashed or unslashed zero.

**CharacterSet**

Selects character table 1 or 2.



## Password Config Menu

Item	Settings (default in bold)
Password Config*	-
Limitation	<b>Disable</b> , Interface, Config, All

\* The default password is blank. You can enter up to 20 characters for the password.

### Password Config

Changes the password. Enter the old password first and then enter the new password twice.

To enter the password, press the ▼ **Down** or ▲ **Up** button to select the character and press the ► **Enter** button to determine the character. After all characters are determined, press the **OK** button.

### Limitation

Changes the restriction range. When **Interface** is selected, the password is required to change the settings in the USB and Network menus. When **Config** is selected, the password is required to enter Quick Print Job or Confidential Job, or to change the settings in all menus. When **All** is selected, the password is required to enter Quick Print Job or Confidential Job, or to change the settings and to perform the items in all menus. Before changing the setting, you have to enter the password set in the Password Config setting.

## Support Menu

Enter the Support Mode by pressing the ▼ **Down** button while turning the printer on, to make Support Menu and Printer Adjust Menu appear.



### Caution:

- Select only the items below from the Support Menu. Do not select any items on the Print Adjust Menu.
- When formatting the CompactFlash or deleting the data, unplug the interface cables and do not print files.

### Format CompactFlash

Formats the CompactFlash memory in the printer if a CompactFlash memory is installed.

### **Format PS3 CompactFlash**

Formats the CompactFlash area where PostScript information is stored if a CompactFlash memory is installed.

### **Delete All CompactFlash Data**

Deletes all data in the CompactFlash memory if a CompactFlash memory is installed.

## ***Bookmark Menu***

The bookmark menu appears by pressing the **OK** button while the LCD panel displays *Ready* or *Sleep*.

In the bookmark menu, the bookmarked setting items are listed and you can select one of them. The following menus are bookmarked by default.

- Reset Menu
- MP Tray Size
- System Information

To register the menus in bookmark, see “How to register menus as bookmarks” on page 80 for details.

---

## ***Status and Error Messages***

This section contains a list of error messages shown on the LCD panel, a brief description of each message and suggestions for correcting the problem. Note that not every message shown on the LCD panel indicates a problem. When the  mark is displayed at the right of the warning message, multiple warnings occur. To confirm all warnings that occur, press the **▼ Down** button to display the *Status Menu*, then press the **► Enter** button. The LCD panel also displays the remaining service life of the consumables and available paper sizes.

### **Bookmark Failed**

The selected menu cannot be registered as a bookmark. Some menus cannot be registered as bookmarks.

### **Bookmark Registered**

The selected menu is registered as a bookmark.

### Calibrating Printer

The printer automatically calibrates itself. This is not an error message, and will clear itself after the calibration process has finished. While the printer displays this message, do not open the covers or turn off the printer.

### Cancel All Print Job

The printer is canceling all print jobs in the printer memory, including jobs the printer is currently receiving or printing. This message appears when the  **Cancel Job** button has been pressed down for more than 2 seconds.

### Cancel Print Job

The printer is canceling the current print job. This message appears when the  **Cancel Job** button has been pressed and released within 2 seconds.

### Cancel Print Job (by host)

The print job is canceled at the printer driver.

### Can't Print

The print data is deleted because it is incorrect.

Make sure the appropriate paper size and printer driver are used.

### Can't Print Duplex

The printer has encountered problems during duplex printing. Make sure you are using an appropriate type and size of paper for the duplex printing. The problem could also be a result of incorrect settings for the paper source you are using. Pressing the **Start/Stop** button will print the rest of the print job on only one side of the paper. Press the  **Cancel Job** button to cancel the print job.

### Can't Use Bookmark

The registered menu cannot be used because the menu is disabled by changing any settings after registered the menu in bookmark.

### CF CHECK

The printer is checking the CompactFlash memory.

### Check Paper Size

The paper size setting is different from the size of paper loaded in the printer. Check to see if the correct size of paper is loaded in the specified paper source.

To clear this error, select `Clear Warning` from the control panel's `Reset Menu`. See "How to access the control panel menus" on page 79 for instructions.

### Check Paper Type

The paper loaded in the printer does not match the paper type setting in the printer driver. Paper that matches only the paper size setting will be used for printing.

To clear this error, select `Clear Warning` from the control panel's `Reset Menu`. See "How to access the control panel menus" on page 79 for instructions.

### Check Transparency

You have loaded media other than Epson Color Laser Transparencies when the Paper Type setting in the printer driver is **Transparency**, or transparencies are loaded when the Paper Type setting in the printer driver is not set to **Transparency**. Completely blank pages are output.

To clear the error, see "Transparencies are output blank from the MP tray" on page 199.

### Collate Disabled

Printing by specifying the number of copies is no longer possible due to a lack of memory (RAM). If this error occurs, print only one copy at a time.

To clear this error, select `Clear Warning` from the control panel's `Reset Menu`. See "How to access the control panel menus" on page 79 for instructions.

### CompactFlash Error

The installed CompactFlash memory is not supported by the printer or you selected `No` when the `Format Required` was displayed on the control panel. Turn off the printer and remove the CompactFlash memory. If `Format Required` is displayed on the control panel, select `Yes`.

### CompactFlash Full

The optional CompactFlash memory is full and you cannot save any data. Delete the unnecessary data from the CompactFlash memory. To clear this error, select **Clear Warnings** from the control panel's **Reset Menu**. For instruction about accessing the control panel menus, see "How to access the control panel menus" on page 79.

### **Correct time using Time Setting**

The current time setting is reset because you did not connect the power cord for a long time. To clear this error, select **Time Settings** from **Clock Menu** and specify the current date and time.

### **Duplex Memory Overflow**

There is not enough memory for duplex printing. The printer prints only on the front and ejects the paper. To clear this error, follow the instructions below.

If **Off** is selected as the **Auto Cont** setting on the control panel's **Setup Menu**, press the **Start/Stop** button to print on the back of the next sheet, or press the  **Cancel Job** button to cancel the print job.

If **On** is selected as the **Auto Cont** setting on the control panel's **Setup Menu**, printing continues automatically after a certain period of time.

### **Feed Roller C2 Needed Soon, Feed Roller C3 Needed Soon, Feed Roller C4 Needed Soon**

This message indicates that the feed roller C2, C3, or C4 is near the end of its service life. You can continue to print until the **Replace Feed Roller C2**, **Replace Feed Roller C3**, or **Replace Feed Roller C4** message appears.

To clear this warning message and continue printing, select **Clear All Warnings** from the control panel's **Reset Menu**. For instruction about accessing the control panel menus, see "How to access the control panel menus" on page 79.

### **Form Data Canceled**

Unable to store form overlay data on the optional CompactFlash memory. Either the CompactFlash memory is not installed correctly, or the maximum number of form overlay files has been reached. Confirm that the optional CompactFlash memory is installed correctly, or delete any form overlay files you no longer need, and then try storing the new overlay again.

To clear this error, select **Clear Warnings** from the control panel's **Reset Menu**. For instruction about accessing the control panel menus, see "How to access the control panel menus" on page 79.

### **Form Feed**

The printer is ejecting paper due to a user request. This message appears when pressing the **Start/Stop** button once to make the printer offline, then holding down the **Start/Stop** button for more than 2 seconds in order not to receive form feed command.

### Format Error ROM A

An unformatted ROM module has been inserted.

To clear this error, either press the **Start/Stop** button or turn off the printer and remove the ROM module, then reinstall the ROM module. If that fails to clear the error, contact your dealer.

### Format Required

The installed CompactFlash memory needs to be formatted to use it with the printer.

Select **Yes** to format the memory, or select **No** to cancel formatting. If you select **No**, CompactFlash Error is displayed and you cannot use the memory for the printer. In that case, turn off the printer and remove the CompactFlash memory.

### Formatting CF

The CompactFlash memory is being formatted.

### Fuser Needed Soon

This message indicates that the fuser unit is near the end of its service life. You can continue to print until the **Replace Fuser** message appears.

To clear this warning message and continue printing, select **Clear All Warnings** from the control panel's **Reset Menu**. For instruction about accessing the control panel menus, see "How to access the control panel menus" on page 79.

### Image Optimum

There is insufficient memory to print the page at the specified print quality. The printer automatically lowers the print quality so that it can continue printing. If the quality of the printout is not acceptable, try simplifying the page by limiting the number of graphics or reducing the number and size of fonts.

To clear this error, select **Clear Warning** from the control panel's **Reset Menu**. See "How to access the control panel menus" on page 79 for instructions.

Turn the **Image Optimum** setting off on the control panel's **Printing Menu** if you do not want the printer to automatically lower the print quality to continue printing.

You may need to increase the amount of printer memory to be able to print at the desired print quality for your document. For more information on adding memory, see “Memory Module” on page 150.

### **Install Photocon uuuu**

The wrong photoconductor unit is installed in the indicated color position in the printer or the position is empty. (The letters C, M, Y, or K appear in place of uuuu and indicate the colors Cyan, Magenta, Yellow, and Black respectively.)

Install the indicated cartridges. See “Photoconductor Unit” on page 165.

### **Install uuuu TnrCart**

The wrong toner cartridge is installed in the indicated color toner cartridge position in the printer or the position is empty. (The letters C, M, Y, or K appear in place of uuuu and indicate the colors Cyan, Magenta, Yellow, and Black respectively.)

Install the indicated cartridges. See “Toner Cartridge” on page 161.

### **Install Waste Toner Box**

The waste toner collector is not installed, or is installed incorrectly. If there is no waste toner collector installed, install one in the printer. If there is a waste toner collector already installed, try removing it and reinstalling it. See “Waste Toner Collector and Filter” on page 170.

### **Invalid AUX I/F Card**

This message means that the printer cannot communicate with the installed optional interface card. Turn off the printer, remove the card, then reinstall it.

### **Invalid Data**

The spool file on the driver is deleted while printing or the data is abnormal. Press the **Start/Stop** button to clear the error.

### **Invalid N/W Module**

There is no network program, or the network program cannot be used with your printer. Contact a qualified service representative.

### **Invalid PS3**

There are errors in the ROM module. Turn off the printer and contact your dealer.

### Invalid ROM A

The printer cannot read the installed optional ROM module. Turn off the printer, then remove the ROM module.

### Jam Paper Size Error

The paper jam occurred because the loaded paper size is different from the specified paper size. Remove the jammed paper. See “Clearing Jammed Paper” on page 183 for instructions on removing the jammed paper.

### Maintenance Unit Needed Soon

This message indicates that the maintenance unit is near the end of its service life. You can continue to print until the `Replac` `Maintenance Unit` message appears.

To clear this warning message and continue printing, select `Clear All Warnings` from the control panel's `Reset Menu`. For instruction about accessing the control panel menus, see “How to access the control panel menus” on page 79.

### Manual Feed ssss

The manual feed mode is specified for the current print job. Make sure the paper size indicated by `ssss` is loaded, then press the **Start/Stop** button.

### Memory Overflow

The printer has insufficient memory to execute the current task. Press the **Start/Stop** button on the control panel to resume printing, or press the  **Cancel Job** button to cancel the print job.

### Need Memory

The printer has insufficient memory to complete the current print job.

To clear this error message, select `Clear Warning` from the control panel's `Reset Menu`. See “How to access the control panel menus” on page 79 for instructions.

To prevent this problem from recurring, add more memory to your printer as described in “Memory modules” on page 259, or reduce the resolution of the image to be printed.

### Non-Genuine Toner Cartridge



The installed toner cartridge is not a genuine Epson product. Installing a genuine toner cartridge is recommended. The printout and remaining service life of each toner cartridge displayed on the control panel may be different from those when using genuine EPSON toner cartridges. Epson shall not be liable for any damages or problems arising from the use of consumable products not manufactured or approved by Epson.

Install a genuine Epson product, or **Clear All Warnings of the Reset Menu** on the control panel to clear the warning message. See “Toner Cartridge” on page 161 for instructions on replacing the toner cartridge.

### **NonGenuine Toner uuuu**

The installed toner cartridge is not a genuine Epson toner cartridge. The printout and remaining service lives of the toner cartridges displayed on the control panel may be different from those when using genuine EPSON toner cartridges. Epson shall not be liable for any damages or problems arising from the use of consumable products not manufactured or approved by Epson. Installing a genuine toner cartridge is recommended. Press the **Start/Stop** button on the control panel to resume printing.

### **Offline**

The printer is not ready to print. Press the **Start/Stop** button.

### **Open (www Open)**

The specified cover (www) does not close securely. Open the cover once, and then close.

### **Optional RAM Error**

The optional memory module may be corrupted or incorrect. Replace it with a new one.

### **Paper Jam WWWW**

The location where the paper jam occurred is displayed at .  indicates the location of the error.

If a paper jam occurs at two or more locations simultaneously, the corresponding multiple locations are displayed.

<b>Location</b>	<b>Description</b>
Paper Jam D, A	Paper is jammed at the Duplex Unit cover or cover A. For instructions on clearing this type of paper jam, see “Paper Jam D (Duplex Unit cover)” on page 189 and “Paper Jam A (Cover A)” on page 184.

Location	Description
Paper Jam D, A, G	Paper is jammed at the Duplex Unit cover, cover A, or paper path G. For instructions on clearing this type of paper jam, see "Paper Jam D (Duplex Unit cover)" on page 189, "Paper Jam A (Cover A)" on page 184, and "Paper Jam G (Paper path G)" on page 192.
Paper Jam A, B, H	Paper is jammed at cover A, cover B, or cover H. For instructions on clearing this type of paper jam, see "Paper Jam A (Cover A)" on page 184 and "Paper Jam B H (Cover B or H)" on page 185.
Paper Jam A	Paper is jammed at cover A. For instructions on clearing this type of paper jam, see "Paper Jam A (Cover A)" on page 184.
Paper Jam A, G	Paper is jammed at cover A or paper path G. For instructions on clearing this type of paper jam, see "Paper Jam A (Cover A)" on page 184 and "Paper Jam G (Paper path G)" on page 192.
Paper Jam A, G, E2 Paper Jam A, G, E3 Paper Jam A, G, E4	Paper is jammed at cover A, paper path G, or cover E. For instructions on clearing this type of paper jam, see "Paper Jam A (Cover A)" on page 184, "Paper Jam G (Paper path G)" on page 192, and "Paper Jam E2, Paper Jam E3, Paper Jam E4 (Cover E2, Cover E3, Cover E4)" on page 193.
Paper Jam E2 Paper Jam E3 Paper Jam E4	Paper is jammed at cover E. For instructions on clearing this type of paper jam, see "Paper Jam E2, Paper Jam E3, Paper Jam E4 (Cover E2, Cover E3, Cover E4)" on page 193.

### Paper Out tttt sssss

There is no paper in the specified paper source (tttt). Load paper of the size (ssssss) into the paper source.

### Paper Set tttt sssss

The paper loaded in the specified paper source (tttt) does not match the required paper size (ssssss). Replace the loaded paper with the correct size paper and press the **Start/Stop** button to resume printing, or press the  **Cancel Job** button to cancel the print job.

If you press the **Start/Stop** button without replacing the paper, the printer will print on the loaded paper even though it does not match the required size.

### Password Changed

The password has been changed successfully.

### Photocon Trouble uuuu

There is a problem with the photoconductor unit of the indicated color. Remove the photoconductor unit and reinsert it. If that fails to clear the error, replace the photoconductor unit. To install the photoconductor unit, see “Photoconductor Unit” on page 165.

### **Photocon uuuu Needed Soon**

This message indicates that the photoconductor unit of the indicated color is near the end of its service life. You can continue to print until the `Replace Photocon uuuu` message appears.

### **Please wait for print**

Printing cannot start because the previous job is being processed. Try again after a few seconds.

### **Print Overrun**

The required time to process the print data exceeded the print engine speed because the current page is too complex. Press the **Start/Stop** button to resume printing, or press the  **Cancel Job** button to cancel the print job. If this message appears again, select `On` as the `Page Protect` setting in the control panel's `Setup Menu` or select **Avoid Page Error** on the printer driver.

If you continue to receive this message when printing a particular page, try simplifying the page by limiting the number of graphics or reducing the number and size of fonts.

To avoid this error, it is recommended that you set the `Page Protect` setting to `On` and add more memory to the printer. See “Setup Menu” on page 87 and “Memory Module” on page 150 for details.

### **PS3 CompactFlash Full**

The memory allocated for writing PostScript 3 commands on the optional CompactFlash memory is full.

To clear this error, select `Clear Warnins` from the control panel's `Reset Menu`. For instruction about accessing the control panel menus, see “How to access the control panel menus” on page 79.

### **RAM CHECK**

The printer is checking the RAM.

### **Ready**

The printer is ready to receive data and print.

### **Replace Feed Roller C2, Replace Feed Roller C3, Replace Feed Roller C4**

The feed roller C2, C3, or C4 has reached the end of its service life and needs to be replaced. If this error occurs, consult your dealer.

### **Replace Fuser**

The fuser has reached the end of its service life and needs to be replaced. If this error occurs, consult your dealer.

### **Replace Maintenance Unit**

The maintenance unit has reached the end of its service life and needs to be replaced. If this error occurs, consult your dealer.

### **Replace Photocon uuuu**

The indicated photoconductor unit has reached the end of its service life and need to be replaced. “Photoconductor Unit” on page 165 for instructions.

### **Replace Toner uuuu**

The indicated toner cartridge has reached the end of its service life and need to be replaced. See “Toner Cartridge” on page 161 for instructions.

### **Replace Transfer Unit**

The transfer unit has reached the end of its service life and needs to be replaced. If this error occurs, consult your dealer.

### **Replace Waste Toner Box**

The waste toner collector has reached the end of its service life and needs to be replaced. See “Waste Toner Collector and Filter” on page 170 for instructions.

### **Reserve Job Canceled**

The printer cannot store the data of your print job using the Reserve Job function. The maximum number of print jobs stored on the printer's memory has been reached, or the memory has no more memory available to store a new job. To store a new print job, delete a previously stored job. Also, if you have any Confidential Jobs stored, printing those jobs will make more memory available.

You may also increase the available memory space by changing the RAM Disk setting to Normal or Maximum. For details, see “Setup Menu” on page 87.

To clear this error, select **Clear Warnings** from the control panel's **Reset Menu**. For instruction about accessing the control panel menus, see "How to access the control panel menus" on page 79.

## **Reset**

The printer's current interface has been reset and the buffer has been cleared. However, other interfaces are still active and retain their settings and data.

## **Reset All**

All printer settings have been reset to the default configuration, or to the last settings that were saved.

## **Reset to Save**

A control panel menu setting was changed while the printer was printing. Press the **Start/Stop** button to clear this message. The setting will become effective after printing has finished.

Alternatively you can clear this message by performing **Reset** or **Reset All** on the control panel. However, the print data will be deleted.

## **ROM CHECK**

The printer is checking the ROM.

## **SELF TEST**

The printer is currently performing a self test and initialization.

## **Service Req Cffff/Service Req Exxx**

A controller error or a print engine error has been detected. Turn off the printer. Wait at least 5 seconds, then turn it back on. If the error message still appears, write down the error number listed on the LCD panel (Cffff/Exxx), turn off the printer, unplug the power cord, then contact a qualified service representative.

## **Set Release Lever to ppp Position**

The position of the release lever is incorrect. Open cover A and cover B, change the release lever position to **PPP**, and then close cover B and cover A. (The position **Normal** or **Envelope** appears in place of **PPP**.)

## **Sleep**

The printer is currently in the power-save mode. This mode is canceled when the printer receives print data.

### **TonerCart Error uuuu**

A read/write error has occurred for the indicated toner cartridges. (The color Cyan(C), Magenta(M), Yellow(Y), or Black(K) appears in place of uuuu.)

Remove the toner cartridges and reinsert them. If that fails to clear the error, replace the toner cartridges.

To install the indicated cartridges. See “Toner Cartridge” on page 161.

### **Toner Low (uuuu Toner Low)**

This message indicates that the toner cartridge for the indicated color is near the end of its service life. Prepare a new toner cartridge.

### **Transfer Unit Needed Soon**

This message indicates that the transfer unit is near the end of its service life. You can continue to print until the `ReplacE Transfer Unit` message appears.

### **Turn Paper Cassette 1/ Turn Paper Cassette 2/ Turn Paper Cassette 3/ Turn Paper Cassette 4**

The direction of the paper loaded in the specified paper cassette does not match the required paper direction. Turn the paper direction to landscape.

### **Unable Clear Error**

The printer cannot clear an error message because the error status still remains. Try solving the problem again.

### **Warming Up**

The printer is warming up the fuser to be ready to print.

### **Waste Toner Box Near Full**

The waste toner collector is near full of toner.

### **Write Error ROM A, Write Error ROM P**

This message indicates an internal error in the printer. Reset the printer. If this error persists, consult your dealer.

### **Writing ROM A, Writing ROM P**

This message indicates that a ROM module in the slot is being written. Please wait until this message disappears.

### **Wrong Password**

No print jobs have been saved with the password you entered.

### **Wrong Photocon uuuu**

An inappropriate photoconductor unit is installed. Install only the photoconductor unit listed in “Consumable products” on page 27.

See “Photoconductor Unit” on page 165 for instructions on replacing the photoconductor unit. (The letters C, M, Y, or K appear in place of uuuu and indicate the colors Cyan, Magenta, Yellow, and Black respectively.)

### **Wrong Toner Cartridge uuuu**

An inappropriate toner cartridge is installed. Install only the toner cartridge listed in “Consumable products” on page 27.

See “Toner Cartridge” on page 161 for instructions on replacing the toner cartridge. (The letters C, M, Y, or K appear in place of uuuu and indicate the colors Cyan, Magenta, Yellow, and Black respectively.)

---

## ***Printing and Deleting Reserve Job Data***

Print jobs stored on the printer’s memory using the Re-Print Job, Verify Job, and Stored Job options of the Reserve Job function can be printed and deleted using the control panel’s Quick Print Job Menu. Jobs saved using the Confidential Job option can be printed from the Confidential Job Menu. Follow the instructions in this section.

**Note:**

You need to keep sufficient RAM disk capacity in order to use the Reserve Job function. To enable RAM disk, you have to set the RAM Disk setting on the control panel to Normal or Maximum. We recommend installing an optional memory to use this function. For instructions about increasing your printer's memory, see "Installing a memory module" on page 150.

## Using the Quick Print Job Menu

Follow the steps below to print or delete Re-Print Job and Verify Job data.

1. Make sure the LCD panel displays `Ready` or `Sleep`, then press the **▶ Enter** button to access the control panel menus.
2. Press the **▼ Down** button repeatedly until `Quick Print Job Menu` appears on the LCD panel, then press the **▶ Enter** button.
3. Use the **▼ Down** or **▲ Up** button to scroll to the appropriate user name, then press the **▶ Enter** button.
4. Use the **▼ Down** or **▲ Up** button to scroll to the appropriate job name, then press the **▶ Enter** button.
5. Press the **▶ Enter** button, then use the **▼ Down** and **▲ Up** buttons to select the number of copies.

To delete the print job without printing any copies, press the **▼ Down** button to display `Delete` on the LCD panel.

6. Press the **▶ Enter** button to start printing or to delete the data.

## Using the Confidential Job Menu

Follow the steps below to print or delete Confidential Job data.

1. Make sure the LCD panel displays `Ready` or `Sleep`, then press the **▶ Enter** button to access the control panel menus.
2. Press the **▼ Down** button repeatedly until `ConfidentialJobMenu` appears on the LCD panel, then press the **▶ Enter** button.



- Use the ▼ **Down** or ▲ **Up** button to scroll to the appropriate user name, then press the ► **Enter** button.
- Enter your four-digit password.

To enter the password, press the ▼ **Down** or ▲ **Up** button to select the character and press the ► **Enter** button to determine the character. After all characters are determined, press the ► **Enter** button.

**Note:**

*If no print jobs have been saved with the password you entered, Wrong Password appears briefly on the LCD panel then the printer exits the control panel menus. Confirm the password and try again.*

- Use the ▼ **Down** or ▲ **Up** button to scroll to the appropriate job name, then press the ► **Enter** button.
- Use the ▼ **Down** or ▲ **Up** button to display `Print`.

To delete the print job, press the ▼ **Down** or ▲ **Up** button to display `Delete` on the LCD panel.

- Press the ► **Enter** button to start printing or to delete the data.

---

## Printing a Configuration Status Sheet

- Turn on the printer. The LCD panel shows `Ready` or `Sleep`.
- Press the ► **Enter** button three times. The printer prints a configuration status sheet.

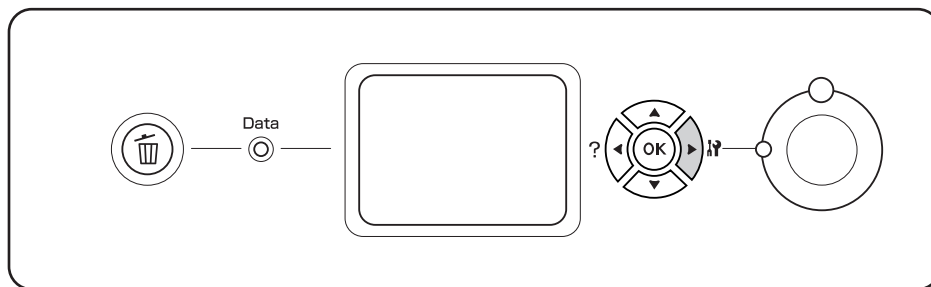

3. Confirm that the information about the installed options is correct. If the options are installed correctly, they appear under Hardware Configuration. If the options are not listed, try reinstalling them.

**Note:**

- If the configuration status sheet does not list your installed options correctly, make sure that they are securely connected to the printer.*
- If you are unable to get the printer to print a correct configuration status sheet, contact your dealer.*
- Print the configuration status sheet on A4 size paper.*



---

## Canceling Printing

You can cancel printing from your computer by using the printer driver.

To cancel a print job before it is sent from your computer, see “Canceling Printing” on page 210.

## Using the Cancel Job button

The  **Cancel Job** button on your printer is the quickest and easiest way to cancel printing. Pressing this button cancels the currently printing job. Pressing the  **Cancel Job** button for more than two seconds deletes all jobs from the printer memory, including jobs the printer is currently receiving or printing.

## Using the Reset menu

Selecting **Reset** from the control panel's **Reset Menu** stops printing, clears the print job being received from the active interface, and clears errors that may have occurred at the interface.

Follow the steps below to use the **Reset Menu**.

1. Press the **▶ Enter** button to access the control panel menus.
2. Press the **▼ Down** button several times until **Reset Menu** appears on the LCD panel, then press the **▶ Enter** button.
3. Press the **▼ Down** button several times until **Reset** to display.

4. Press the ► **Enter** button. Printing is canceled. The printer is ready to receive a new print job.

## Chapter 4

### Installing Options

#### Optional Printer Stand and Paper Cassette Unit

For details about the paper types and sizes that you can use with the optional paper cassette unit, see “Optional paper cassette unit” on page 35. For specifications, see “Optional paper cassette unit” on page 257.

#### Handling precautions

Always pay attention to the following handling precautions before installing the option:

The printer weighs about 60 kg (132 lb). One person should never attempt to lift or carry it alone. Two people should carry the printer, lifting it from the positions shown below.

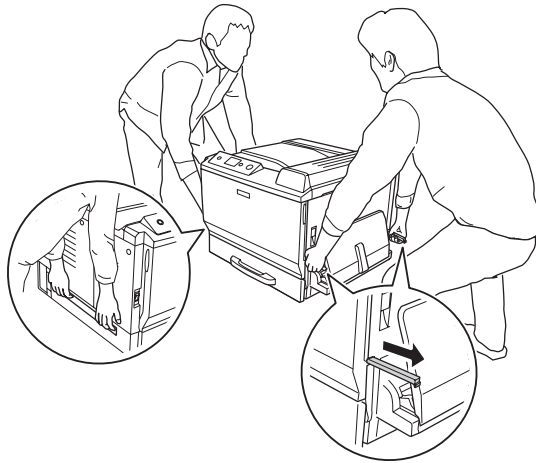

**Warning:**

*If you lift the printer incorrectly, you could drop it and cause injury.*

## Installing the optional printer stand



**Caution:**

Be sure to attach the adjusters and stabilizers to the printer stand. Otherwise, the printer may move and cause an accident.

1. Confirm the bundled items.

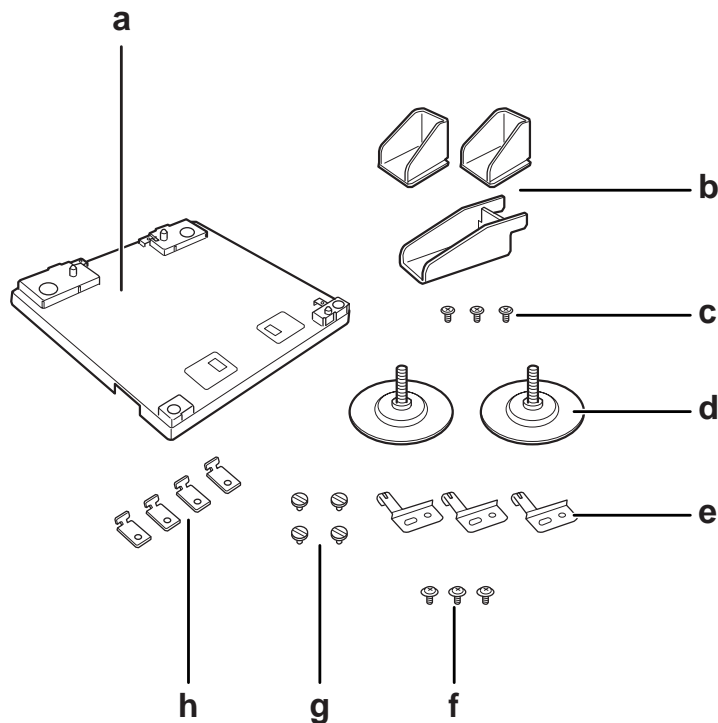

- a. printer stand
- b. stabilizer
- c. screws (for stabilizer)
- d. adjusters
- e. ground plates
- f. screws (for ground plate)
- g. screws (for fitting)
- h. fittings

2. Install the three ground plates on the printer stand with the screws.

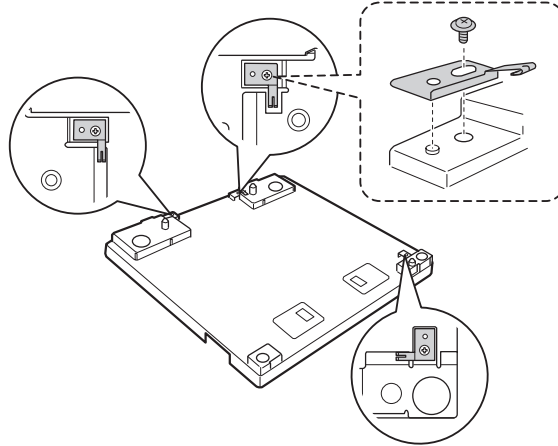

3. Install the two adjusters by turning them.

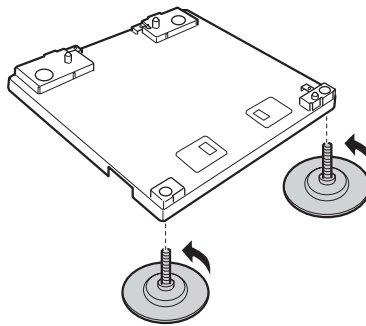

4. Install the three stabilizers with screws.

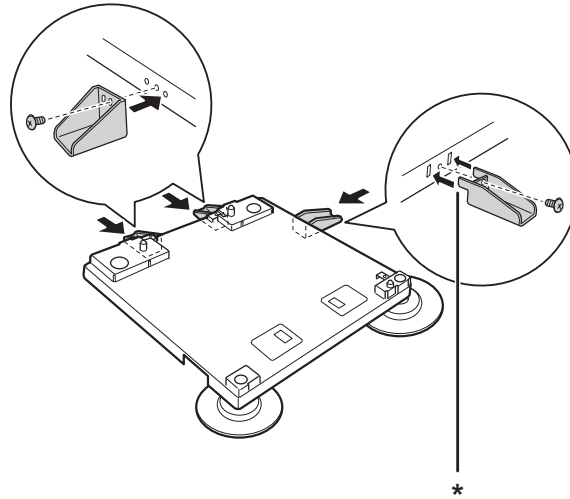

\* tab

**Note:**

*The stabilizer for the right side has a tab. Insert it into the hole before tightening the screw.*

5. Set the lowest optional paper cassette unit on the printer stand aligning the marks.

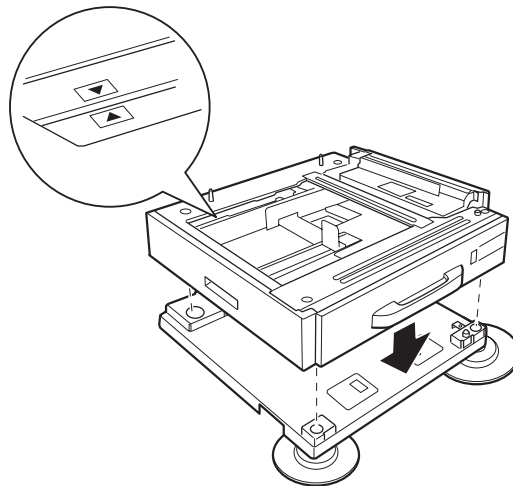

6. Pull out the paper cassette and fix the paper cassette unit to the printer stand with four screws and fittings.

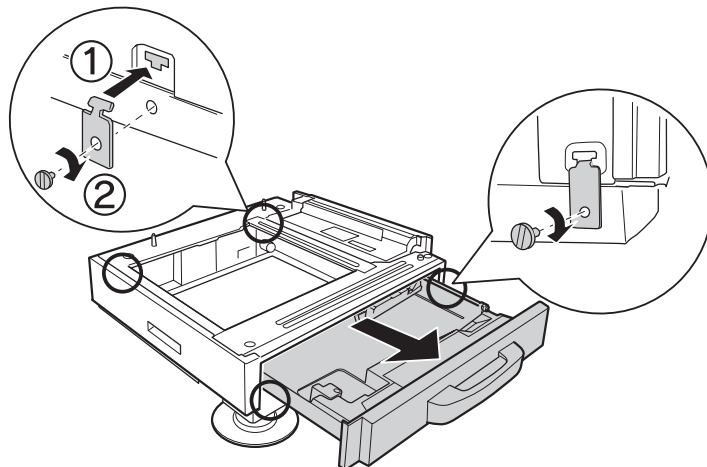

7. Adjust the height by turning the adjusters to prevent the printer stand from moving.

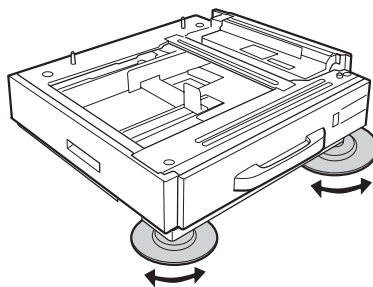

## Installing the optional paper cassette unit

### Note:

*If you use the optional printer stand, install the printer stand to the lowest optional paper cassette unit in advance.*



### Caution:

*To use the optional printer stand, be sure to fix the adjusters before installing the optional paper cassette units. Otherwise, the printer may move and cause an accident.*



1. Turn the printer off and unplug the power cord and interface cable.

**Caution:**

*Make sure to unplug the power cord from the printer to prevent getting an electrical shock.*

2. Carefully take the optional paper cassette unit out from its carton and place it where you intend to set up the printer.

**Note:**

- If you install two or three optional paper cassette units, set them in advance.*
- The instructions below describe installing three optional paper cassette units as an example.*

3. Confirm the bundled items.

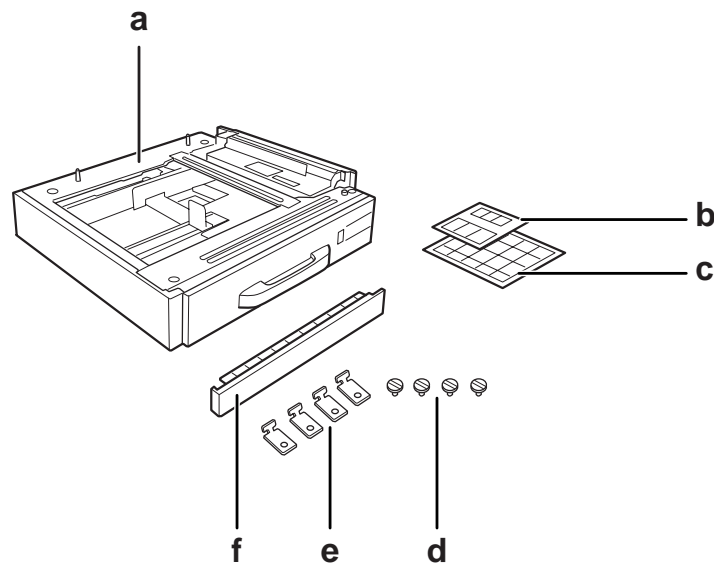

- a. optional paper cassette unit
- b. labels for paper cassettes and cover E
- c. paper size labels
- d. screws
- e. fittings
- f. cover

4. Make sure to remove the cover under the MP tray.

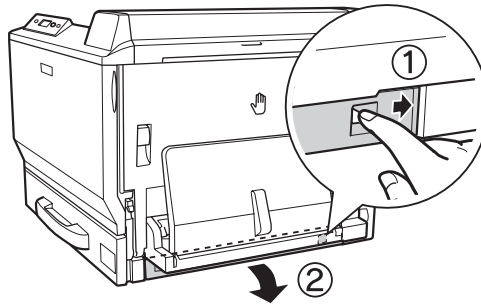
**Caution:**

*Be sure to remove the cover. If you place the printer without removing the cover, the printer may be damaged.*

5. Place the printer onto the optional paper cassette units. Align each of the front corner of the printer with those of the optional paper cassette units, and then lower the printer until it rests securely on the units.

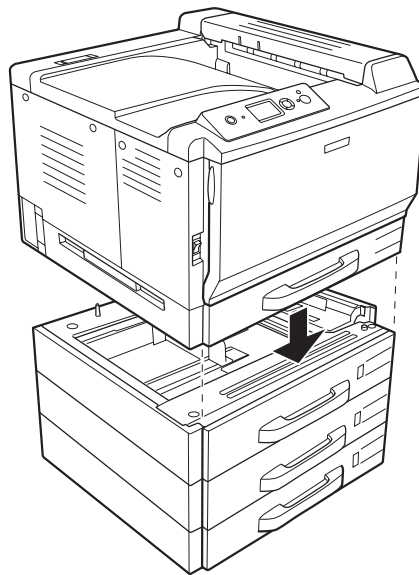
**Note:**

*The printer should be carried by at least two people, holding the printer with their hands in the indicated positions.*

6. Pull out the paper cassettes that are both above and below the connection, and then install the two fittings that are provided.

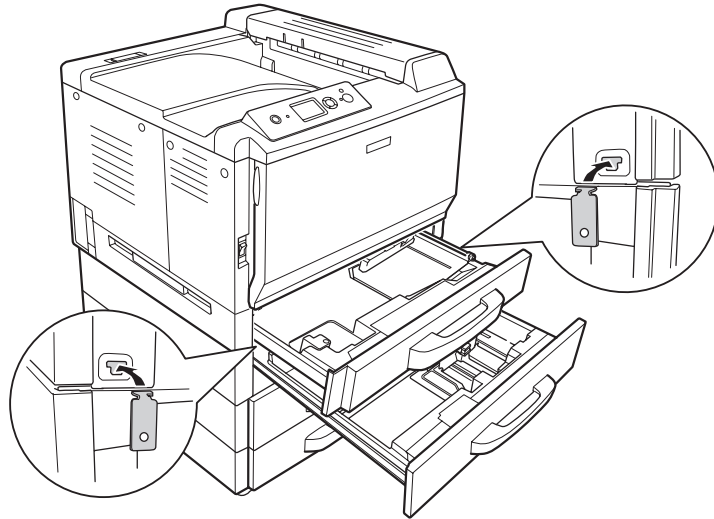

7. Reinsert the upper paper cassette and then fasten the fittings with the two screws that are provided.

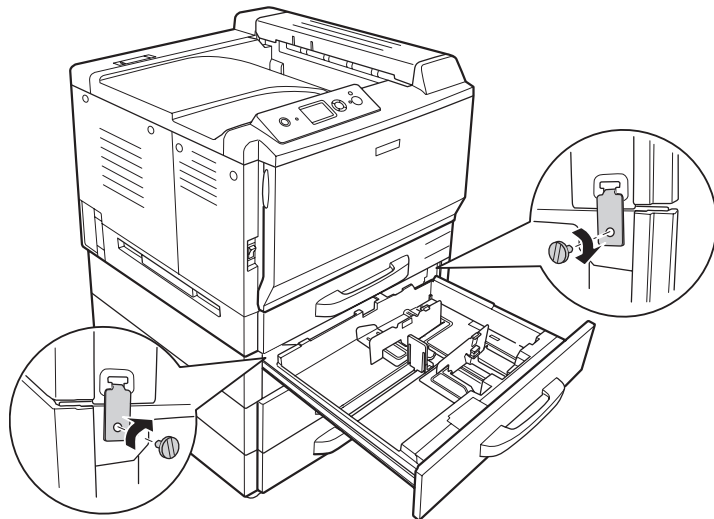

**Note:**

*If you install two or three optional paper cassette units, repeat steps 6 and 7.*

8. Secure the printer and each optional paper cassette unit at the back with two fittings and screws for each connection.

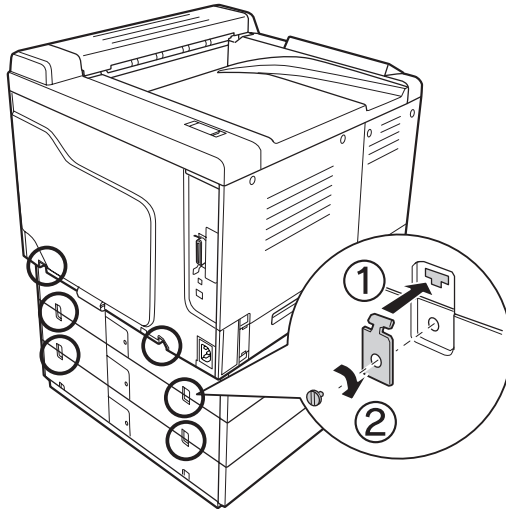

9. Press on the right side of the connector cover, and then remove the connector cover.

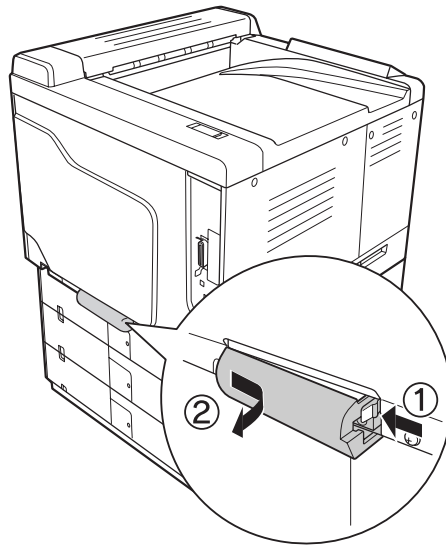

10. Plug the connector of the optional paper cassette unit into the socket on the printer.

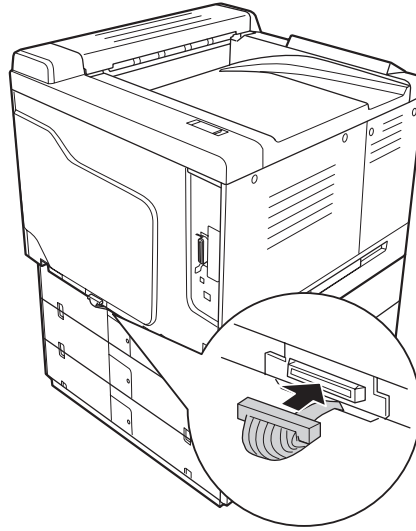

11. Reinstall the connector cover from left side.

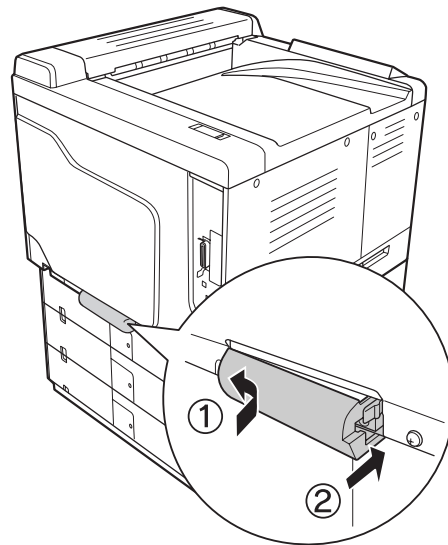

12. Remove the connector cover located on the back of each optional paper cassette units by removing the screw.

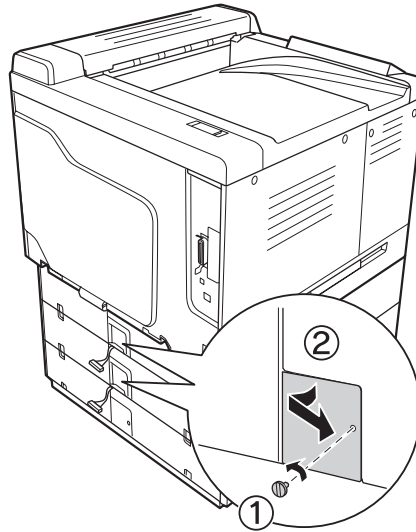

**Note:**

*You do not need to remove the cover on the lowest unit.*

13. Remove the protective tape from the optional paper cassette unit's cables, and then plug the connector of the cable into the socket on the next unit up.

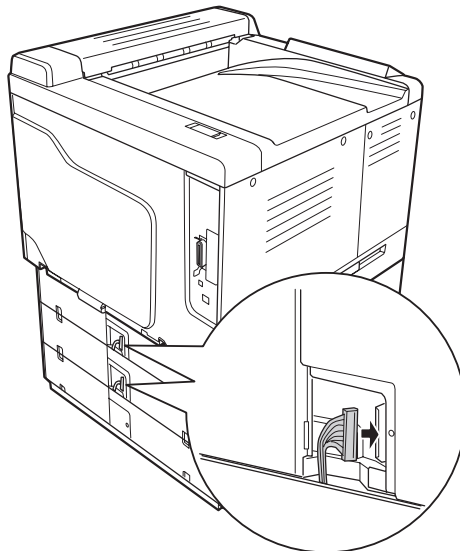

14. Reinstall the connector cover with the screw.

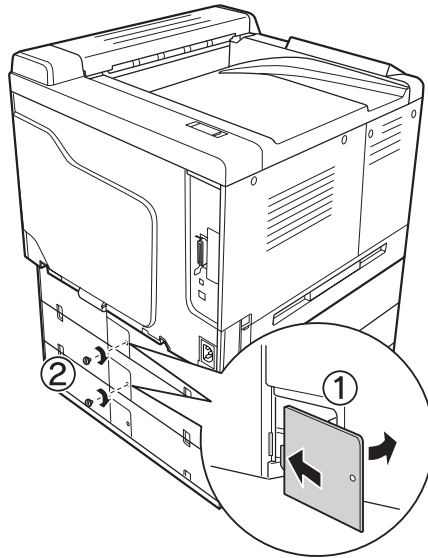

15. Install the cover that comes with the optional paper cassette unit.

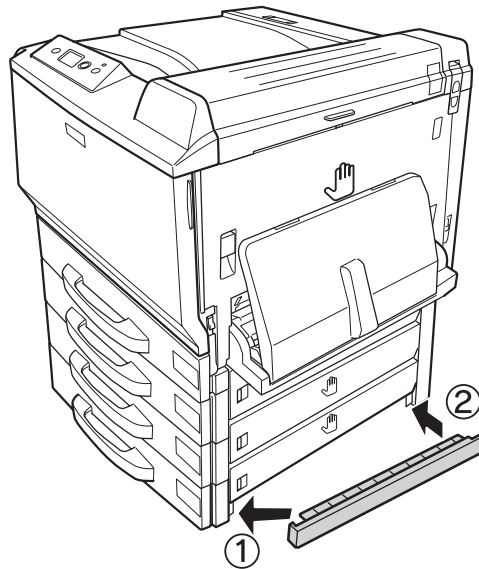

16. Affix the labels onto the front of the paper cassettes and cover E.

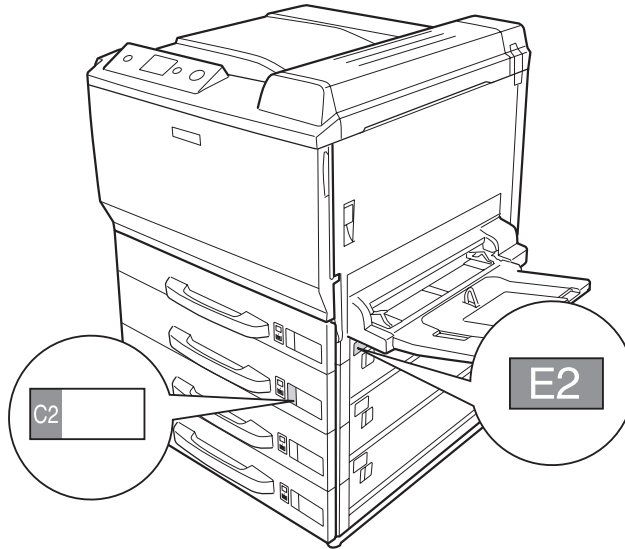

17. Remove the protective materials from each paper cassette, and then load paper.
18. Reconnect the interface cable and power cord, and then turn the printer on.
19. To confirm that the option is installed correctly, print a configuration status sheet. See “Printing a Configuration Status Sheet” on page 195.

**Note for Windows users:**

If EPSON Status Monitor is not installed, you have to make settings manually in the printer driver. Click the **Update the Printer Option Info Manually** button on the Optional Settings tab, and then click **Settings**. Then select **Cassette 2**, **Cassette 3**, and **Cassette 4** from the Optional Paper Sources list on the Optional Settings dialog box based on the installed options and click **OK**.

**Note for Macintosh users:**

When you have attached or removed printer options, you need to delete the printer using **Print & Fax** (for Mac OS X 10.5) or **Print Setup Utility** (for Mac OS X 10.4 or below), and then re-register the printer.

## Removing the optional paper cassette unit

Perform the installation procedure in reverse.



---

## Duplex Unit

For specifications or details about the paper types and sizes that you can use with the Duplex Unit, see “Duplex Unit” on page 258.

### Installing the Duplex Unit

1. Confirm the bundled items.

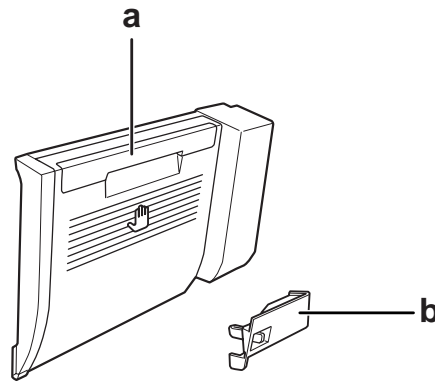

- a. Duplex Unit
- b. connector cover

2. Turn the printer off and unplug the power cord and interface cable.



**Caution:**

*Make sure to unplug the power cord from the printer to prevent getting an electrical shock.*

3. Remove the protective cover at the bottom of cover A.

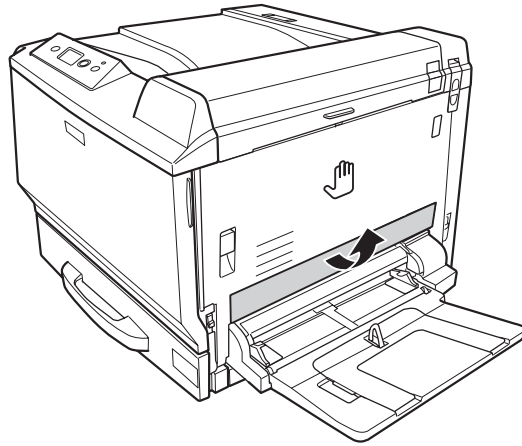

4. Lift up the unlock lever and open cover A.

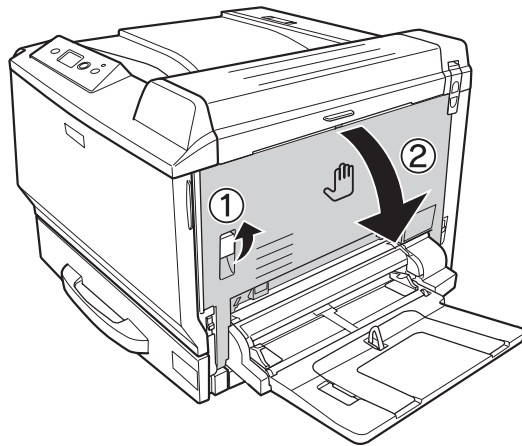

- Remove the protective cover.

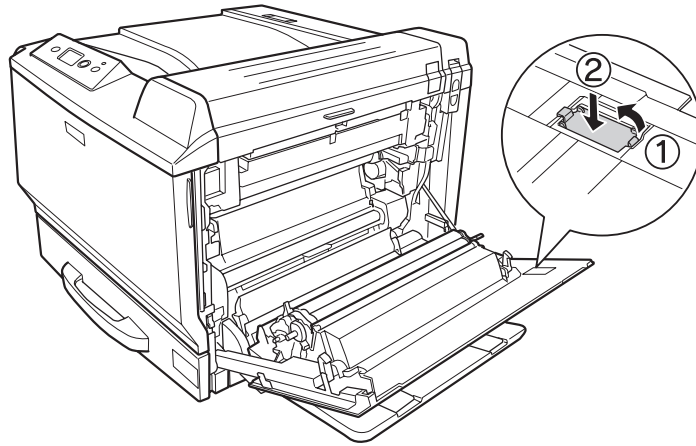

**Note:**

*Keep the protective cover in a safe place. You will need to reattach it if you remove the Duplex Unit.*

- Open cover B.

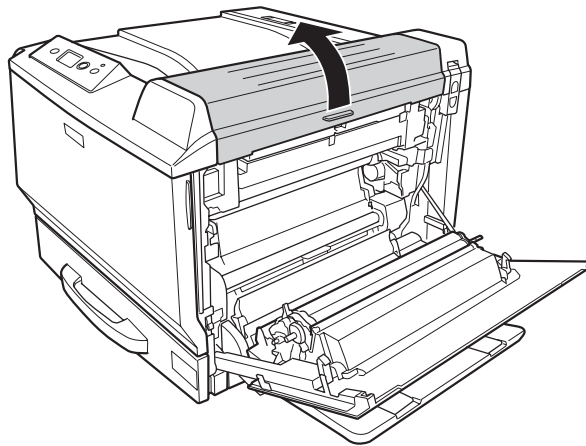

- Remove the protective cover.

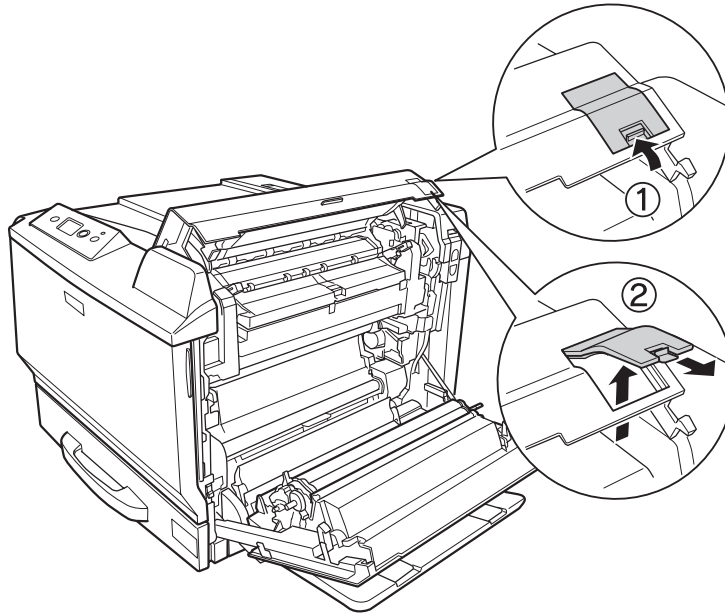

**Note:**

*Keep the protective cover in a safe place. You will need to reattach it if you remove the Duplex Unit.*

- Close cover B, and then cover A.

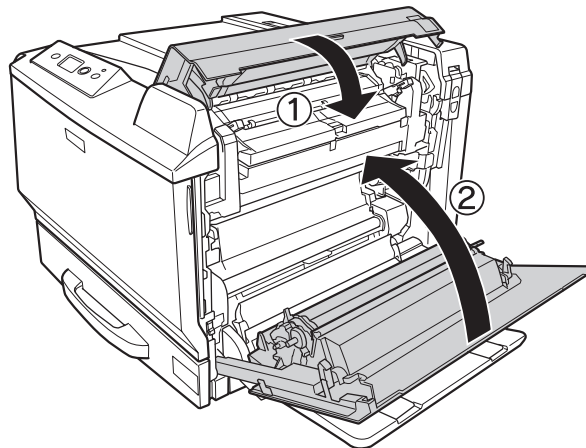

9. Install the Duplex Unit as shown below. Make sure that the unit hooks goes onto the printer's tabs.

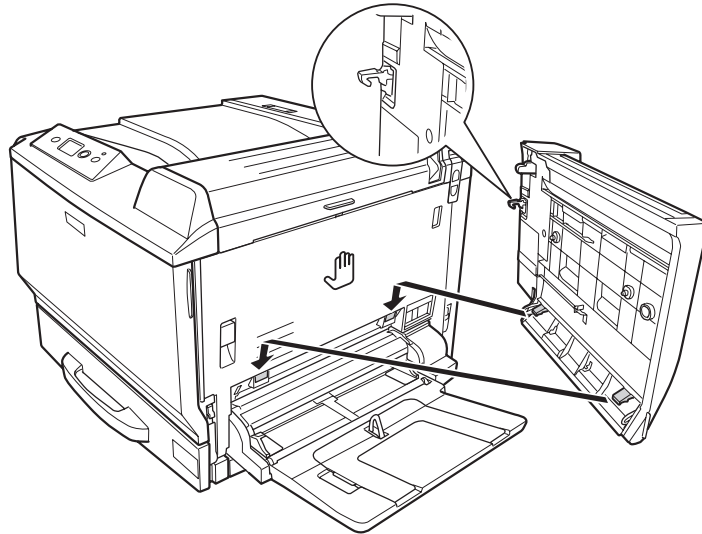

10. Pull the handle at the top of the Duplex Unit cover and open it while holding the Duplex Unit with your hand.

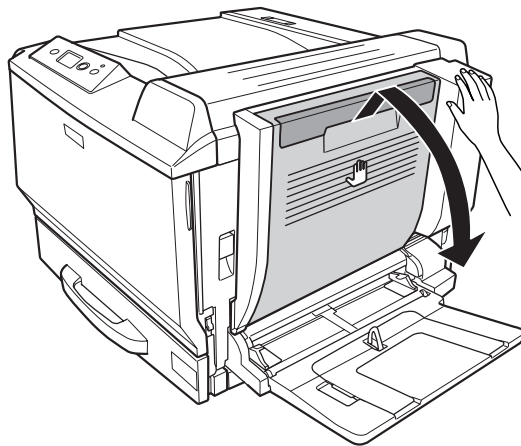

11. Tighten the screws while holding the Duplex Unit with your hand.

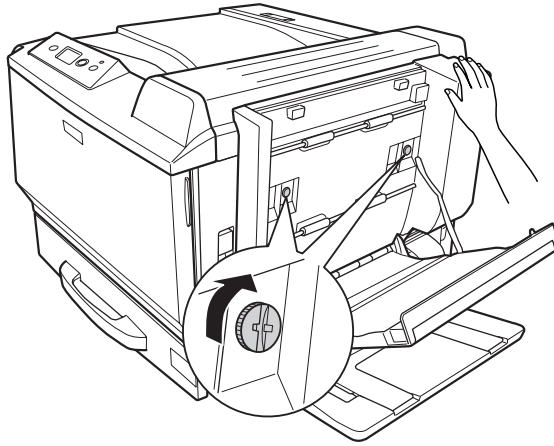

12. Close the Duplex Unit cover.

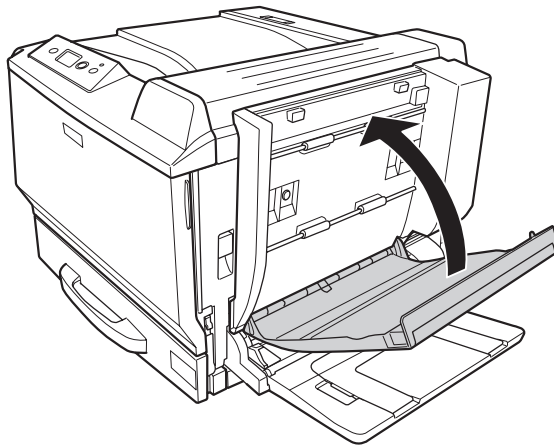

13. Plug the connector of the Duplex Unit into the socket on the printer.

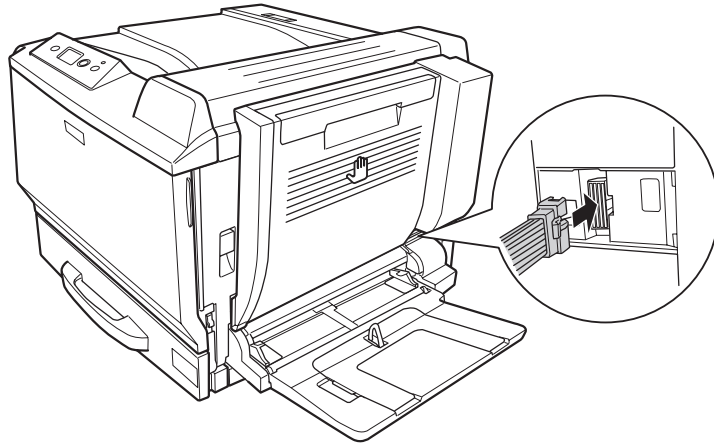

14. Install the connector cover that comes with the Duplex Unit.

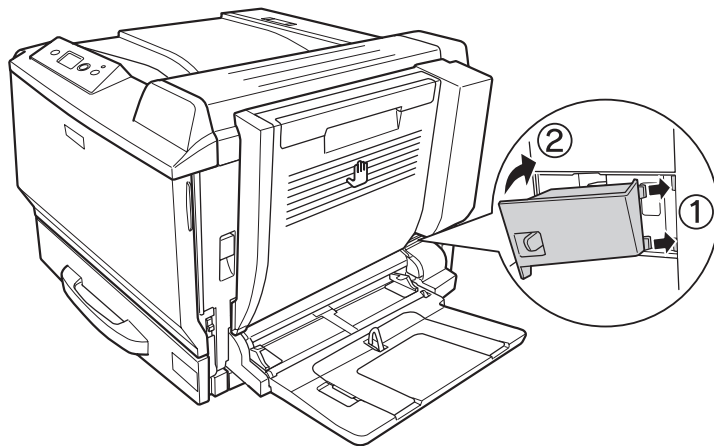

15. Reconnect the interface cable and power cord, then turn the printer on.

To confirm that the option is installed correctly, print a Status Sheet. See “Printing a Configuration Status Sheet” on page 195.

**Note for Windows users:**

*If EPSON Status Monitor is not installed, you have to make settings manually in the printer driver. See “Making Optional Settings” on page 217.*

**Note for Macintosh users:**

When you have attached or removed printer options, you need to delete the printer using **Print & Fax** (for Mac OS X 10.5) or **Print Setup Utility** (for Mac OS X 10.4 or below), and then re-register the printer.

**Removing the Duplex Unit**

1. Turn the printer off and unplug the power cord and interface cable.
2. Remove the connector cover.

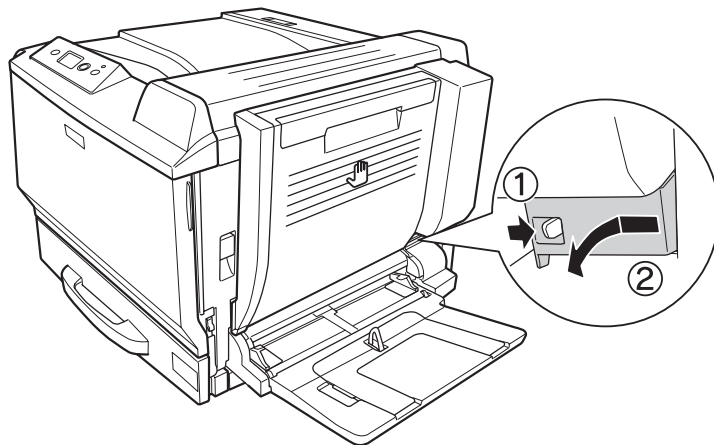

3. Unplug the connector of the Duplex Unit from the socket on the printer.

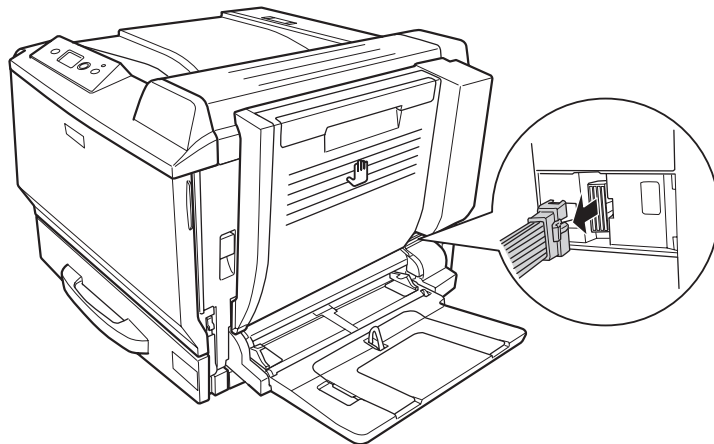



4. Open the Duplex Unit cover by pulling the handle.

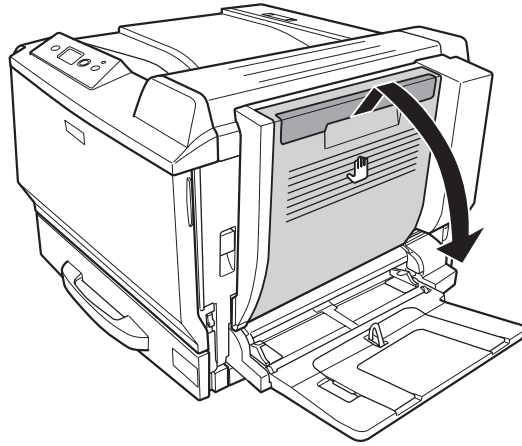

5. Loosen the two screws.

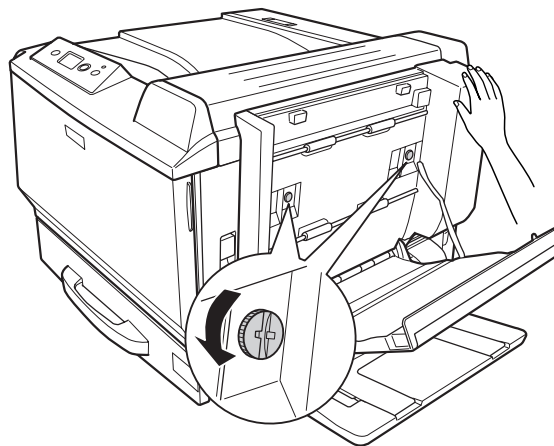

6. Close the Duplex Unit cover.

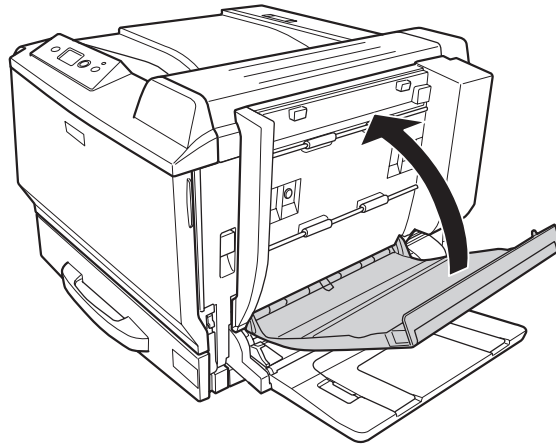

7. Lift up the unlock lever and open cover A while holding the Duplex Unit.

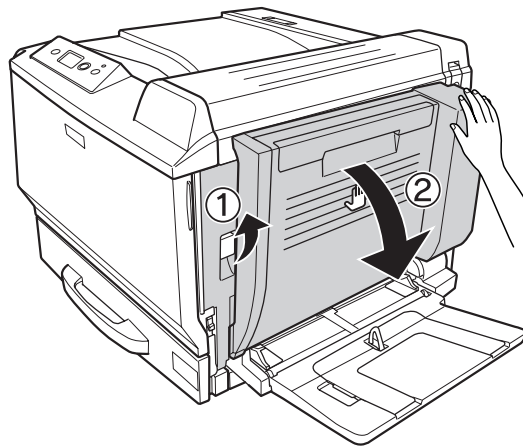

8. Hold cover A and Duplex Unit, and then disengage the hook on the right side.

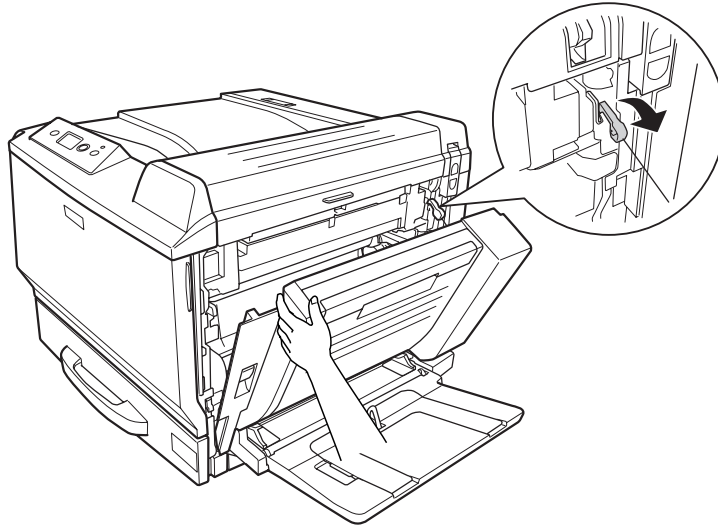

9. Confirm that the direction of the hook is as shown below.

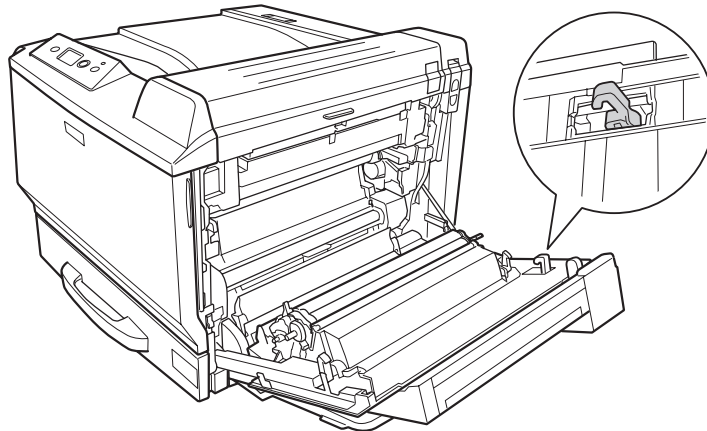
**Caution:**

*If the direction of the hook is not correct, Duplex Unit cannot be installed properly next time.*

10. Remove Duplex Unit by pulling it toward the direction shown below while cover A is slightly open.

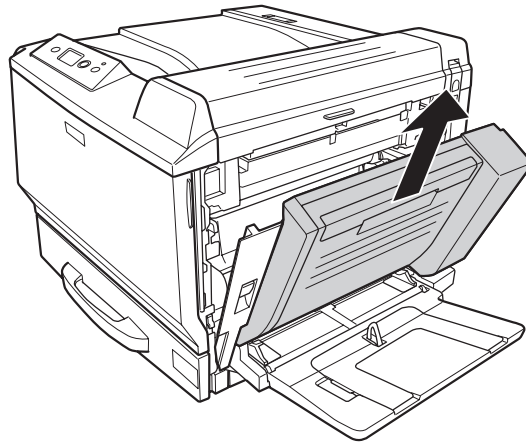

11. Open cover A, and then install the protective cover.

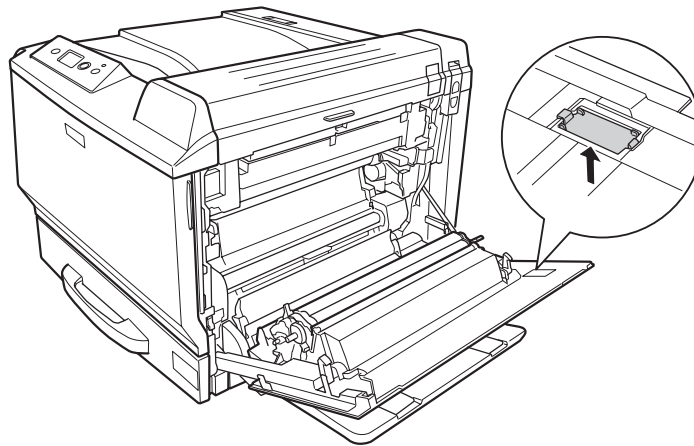

12. Open cover B, and then install the protective cover as shown below.

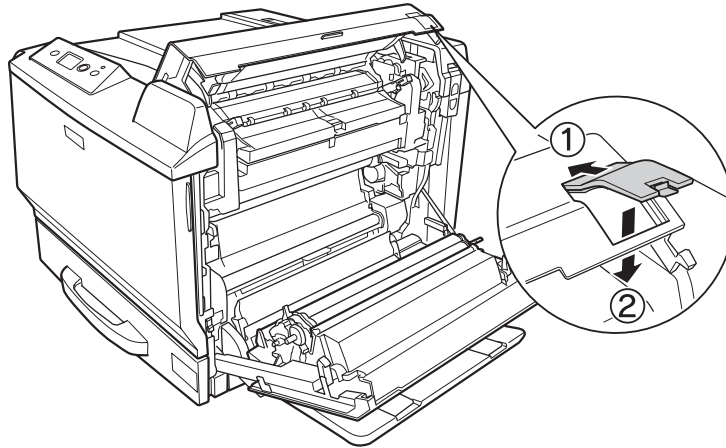

13. Close cover B, and then cover A.

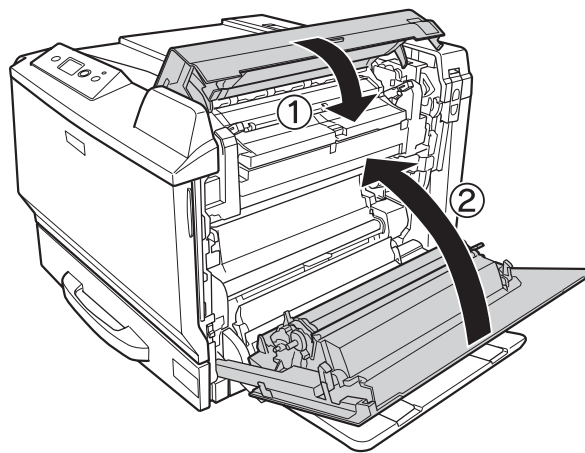

14. Install the protective cover to the bottom of cover A.

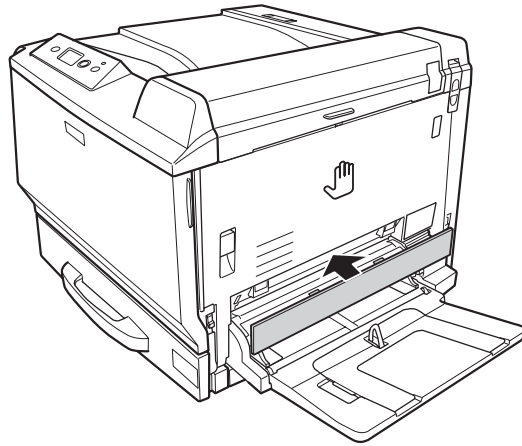

15. Reconnect the interface cable and power cord, then turn the printer on.

---

## Memory Module

By installing Dual In-line Memory Module (DIMM), you can increase printer memory up to 768 MB. You may want to add additional memory if you are having difficulty printing complex graphics.

### Installing a memory module



**Warning:**

*Be careful when working inside the printer as some components are sharp and may cause injury.*



**Caution:**

*Before you install a memory module, be sure to discharge any static electricity by touching a grounded piece of metal. Otherwise, you may damage static-sensitive components.*

1. Turn the printer off and unplug the power cord and interface cable.

2. Loosen the two screws using a screwdriver. Then slide the left side cover upward and remove it.

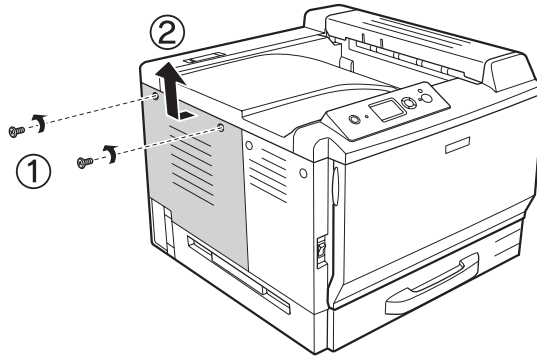

3. Identify the RAM slot.

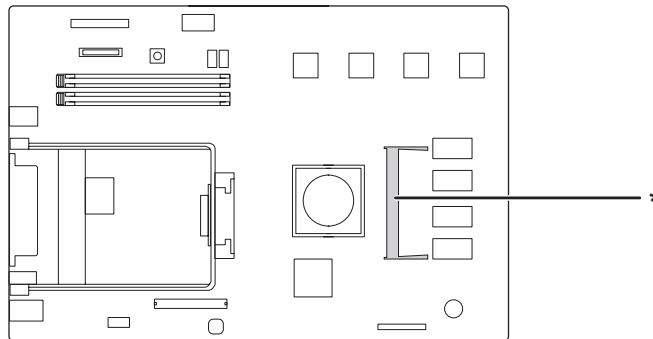

\* expansion RAM slot

4. Confirm that the notch on the expansion memory module matches with that of the slot, and then firmly insert the top edge of the memory module into the slot until it stops. Then press both sides of the memory module down.

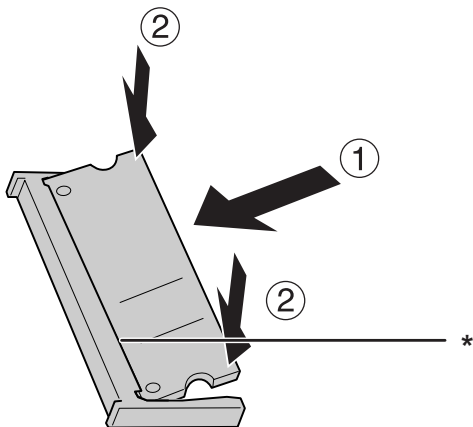

\* notch



**Caution:**

- Do not force the memory module into the slot.
- Be sure to insert the memory module facing the correct way.
- Do not remove any modules from the circuit board. Otherwise, the printer will not work.

5. Reattach the left side cover as shown below.

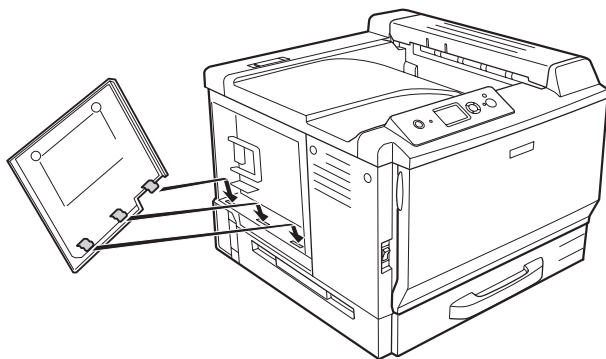



6. Fasten the left side cover with the two screws.

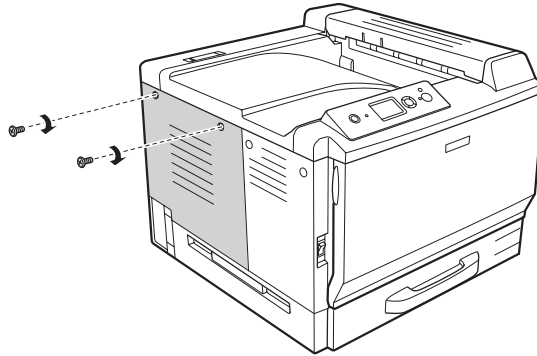

7. Reconnect the interface cable and power cord and turn the printer on.

To confirm that the option is installed correctly, print a Status Sheet. See “Printing a Configuration Status Sheet” on page 195.

**Note for Windows users:**

*If EPSON Status Monitor is not installed, you have to make settings manually in the printer driver. See “Making Optional Settings” on page 217.*

**Note for Macintosh users:**

*When you have attached or removed printer options, you need to delete the printer using **Print & Fax** (for Mac OS X 10.5) or **Print Setup Utility** (for Mac OS X 10.4 or below), and then re-register the printer.*

## Removing a memory module



**Warning:**

*Be careful when working inside the printer as some components are sharp and may cause injury.*



**Caution:**

*Before you remove a memory module, be sure to discharge any static electricity by touching a grounded piece of metal. Otherwise, you may damage static-sensitive components.*

Perform the installation procedure in reverse.

When removing the memory module from its slot, spread apart the clips on each side of the memory slot, and then slide the memory module out.

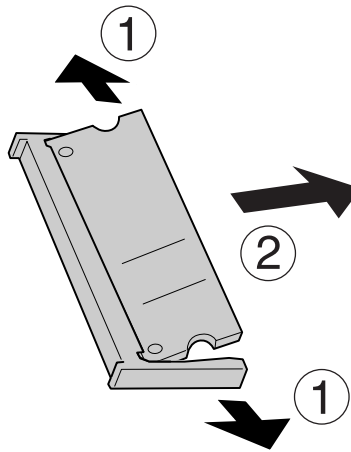

---

## Interface Card

Your printer comes with an empty type-B interface slot. Various optional interface cards are available to expand your printer's interface options.

### Installing an interface card



**Caution:**

*Before you install the interface card, be sure to discharge any static electricity by touching a grounded piece of metal. Otherwise, you may damage static-sensitive components.*

1. Turn the printer off and unplug the power cord and interface cable.

2. Remove the screws and the Type-B interface card slot cover as shown below.

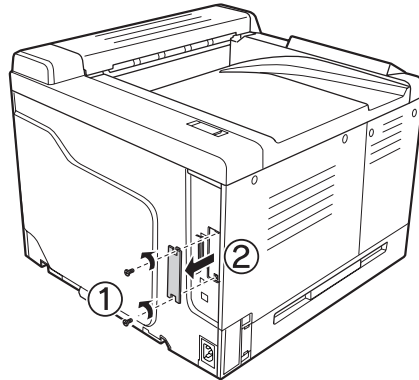

**Warning:**

*Removing screws and covers that are not described in the following instructions will expose high voltage areas.*

**Note:**

*Keep the slot cover in a safe place. You will need to reattach it if you remove the interface card later.*

3. Slide and push the interface card into the slot firmly, then fasten the screw as shown below.

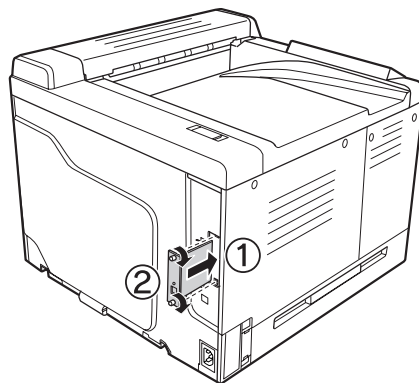

4. Reconnect the interface cable and power cord and turn the printer on.

To confirm that the option is installed correctly, print a Status Sheet. See “Printing a Configuration Status Sheet” on page 195.

## Removing an interface card



### Caution:

Before you remove an interface card, be sure to discharge any static electricity by touching a grounded piece of metal. Otherwise, you may damage static-sensitive components.

Perform the installation procedure in reverse.

---

## CompactFlash Memory

### Installing a CompactFlash memory

An optional CompactFlash memory enables you to store overlay forms, use Reserve Job function, and improve the collate printing environment.



### Warning:

Be careful when working inside the printer as some components are sharp and may cause injury.



### Caution:

Before you install a CompactFlash memory, be sure to discharge any static electricity by touching a grounded piece of metal. Otherwise, you may damage static-sensitive components.

1. Turn the printer off and unplug the power cord and interface cable.
2. Loosen the two screws using a screwdriver. Then slide the left side cover upward and remove it.

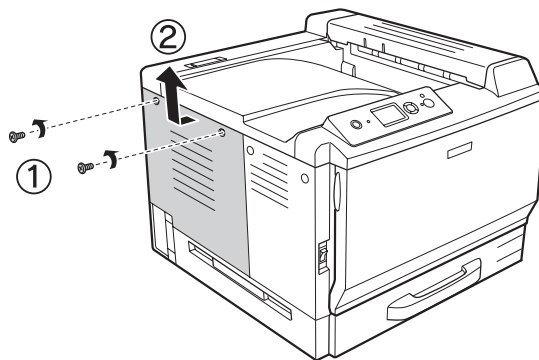

3. Identify the installation slot for a CompactFlash memory.

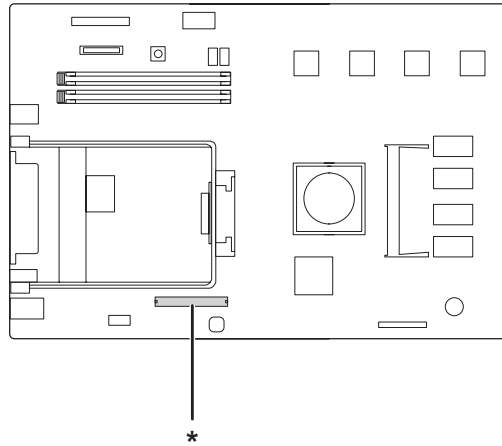

\* CompactFlash memory slot

4. Insert a CompactFlash memory into the slot.

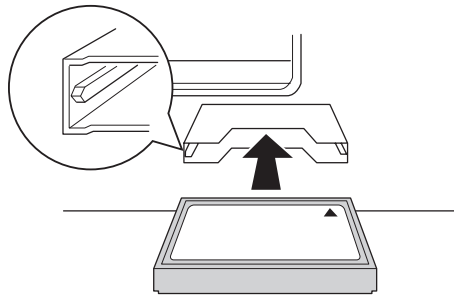

5. Reattach the left side cover as shown below.

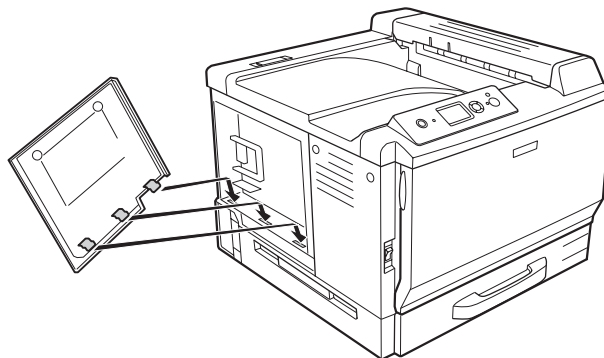

6. Fasten the left side cover with the two screws.

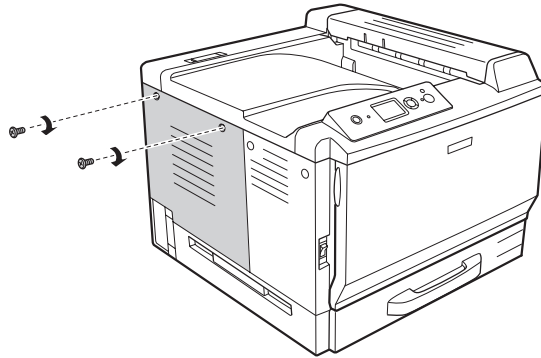

7. Reconnect the interface cable and power cord and turn the printer on.

To confirm that the option is installed correctly, print a Status Sheet. See “Printing a Configuration Status Sheet” on page 195.

**Note for Windows users:**

*If EPSON Status Monitor is not installed, you have to make settings manually in the printer driver. See “Making Optional Settings” on page 217.*

**Note for Macintosh users:**

*When you have attached or removed printer options, you need to delete the printer using **Print & Fax** (for Mac OS X 10.5) or **Print Setup Utility** (for Mac OS X 10.4 or below), and then re-register the printer.*

## Removing a CompactFlash memory



**Warning:**

*Be careful when working inside the printer as some components are sharp and may cause injury.*



**Caution:**

*Before you remove a CompactFlash memory, be sure to discharge any static electricity by touching a grounded piece of metal. Otherwise, you may damage static-sensitive components.*

Perform the installation procedure in reverse.

**Note:**

*Permanently erase all data using specialized software or carry out Delete All CompactFlash Data on Support Menu before you give away or discard CompactFlash memory. Deleting files or formatting the CompactFlash memory from the computer may not erase the data completely.*

*Physically destroying the CompactFlash memory is also recommended when you discard CompactFlash memory.*

## Chapter 5

# Replacing Consumable Products

## Precautions During Replacement

Always observe the following handling precautions when replacing consumable products.

For details about the replacement, see the instructions on the package.

- Provide enough space for the replacement procedure. You will have to open some parts (such as the printer cover) of the printer when you are replacing consumables.
- Do not install used consumable products into the printer.



### Warning:

- Be careful not to touch the fuser, which is marked **CAUTION HIGH TEMPERATURE**, or the surrounding areas. If the printer has been in use, the fuser and surrounding areas may be very hot.*
- Do not dispose of used consumable products in fire, as they may explode and cause injury. Dispose of them according to local regulations.*

## Replacement Messages

If a consumable product reaches the end of its service life, the printer displays the following messages on the LCD panel or the window of EPSON Status Monitor. When this happens, replace the depleted consumable products.

LCD Panel Message	Description
Replace Toner uuuu*	The toner cartridge for the indicated color has reached the end of its service life.
Replace Photocon uuuu*	The photoconductor unit for the indicated color has reached the end of its service life.
Replace Waste Toner Box	The waste toner collector and filter has reached the end of its service life.

\* The color Cyan(C), Magenta(M), Yellow(Y), or Black(K) appears in this position, indicating the color of the toner cartridge or photoconductor unit to be replaced. For example, the message `Replace Toner Yellow(Y)` means that the yellow toner cartridge is near the end of its service life.



**Note:**

Messages appear for one consumable product at a time. After replacing a consumable product, check the LCD panel for replacement messages for other consumable products.

---

## Toner Cartridge

Always observe the following handling precautions when replacing the consumable products:

- Installing a genuine consumable product is recommended. Using a non-genuine consumable product may affect print quality. EPSON shall not be liable for any damages or problems arising from the use of consumable products not manufactured or approved by EPSON.
- When handling a toner cartridge, always place it on a clean, smooth surface.
- Do not install the consumable products that reach the end of service life into the printer.
- If you have moved a toner cartridge from a cool to a warm environment, wait for at least one hour before installing it to prevent damage from condensation.

**Warning:**

- Do not touch the toner. Keep the toner away from your eyes. If toner gets on your skin or clothes, wash it off with soap and water immediately.
- Keep consumable products out of the reach of children.
- Do not dispose of a used toner cartridge in fire, as it may explode and cause injury. Dispose of it according to local regulations.
- If toner is spilled, use a broom and dustpan or a damp cloth with soap and water to clean it up. Because the fine particles can cause a fire or explosion if they come into contact with a spark, do not use a vacuum cleaner.

1. Open cover F.

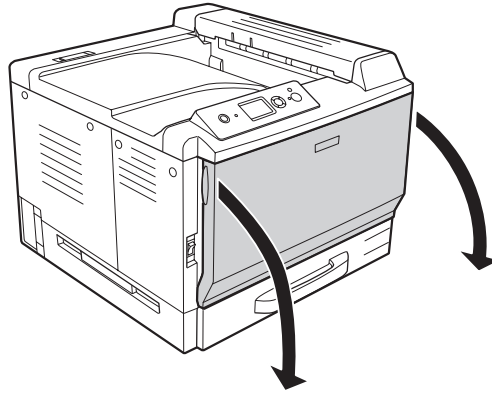

2. Push the arrow part as shown below, and then pull out the toner cartridge.

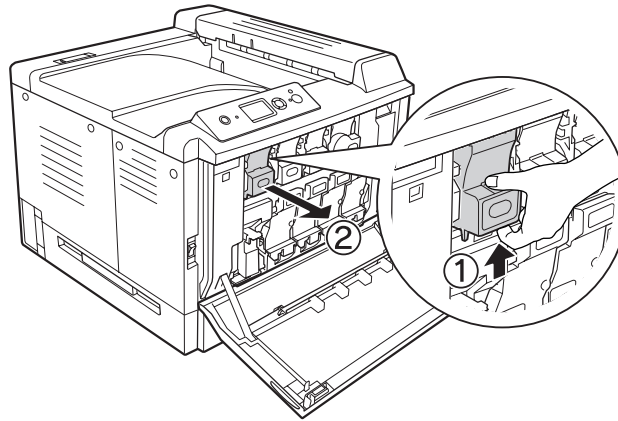

**Note:**  
Place the removed toner cartridge face-down.

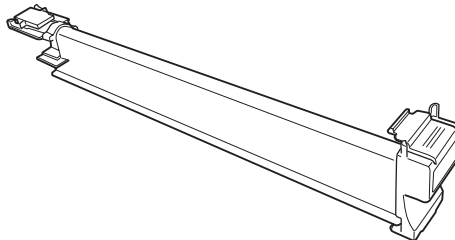

3. Take the new toner cartridge out of its package.

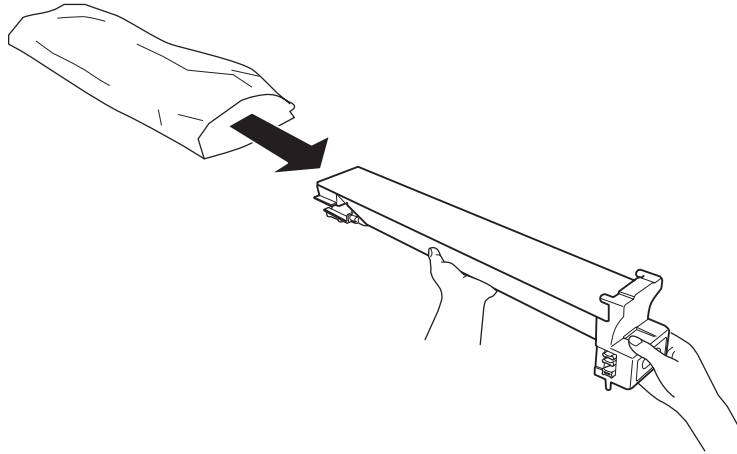

4. Shake the toner cartridge a few times gently.

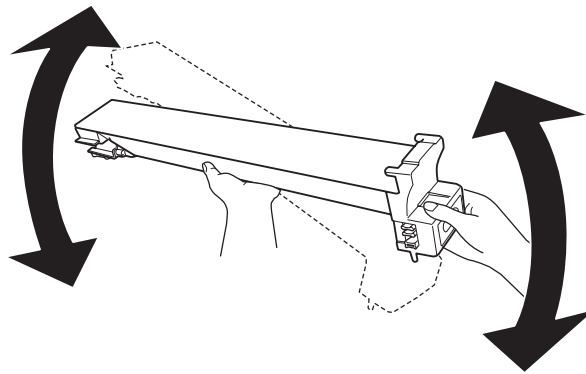

5. Align the color marks on the toner cartridge with those of the printer, and then insert the toner cartridge all the way until it clicks.

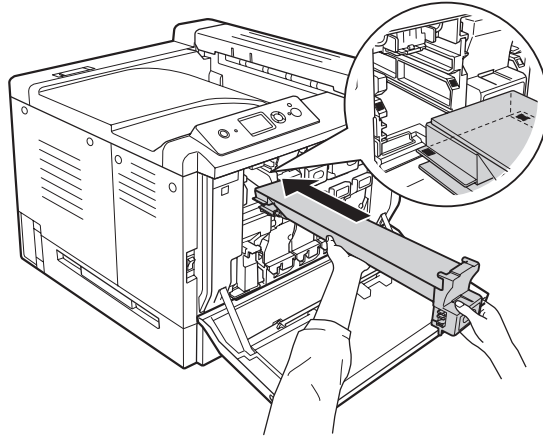

Go to step 5 when replacing a black toner cartridge, go to step 7 when replacing other toner cartridges.

6. Remove the odor filter.

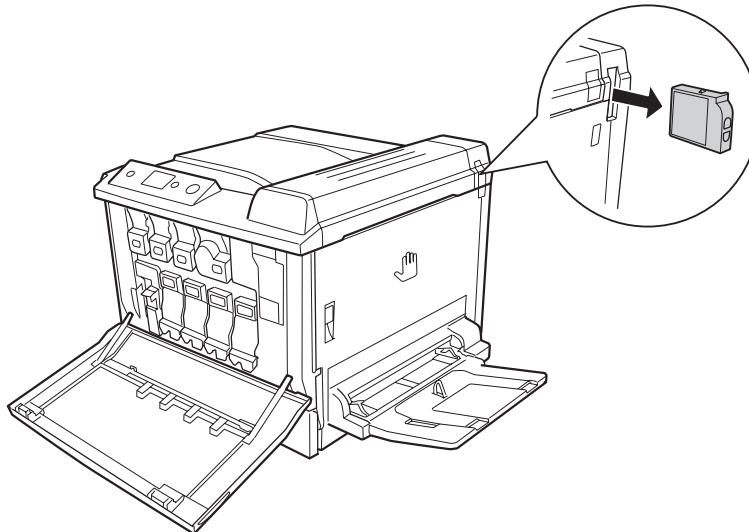

7. Install the new odor filter that comes with the black toner cartridge.

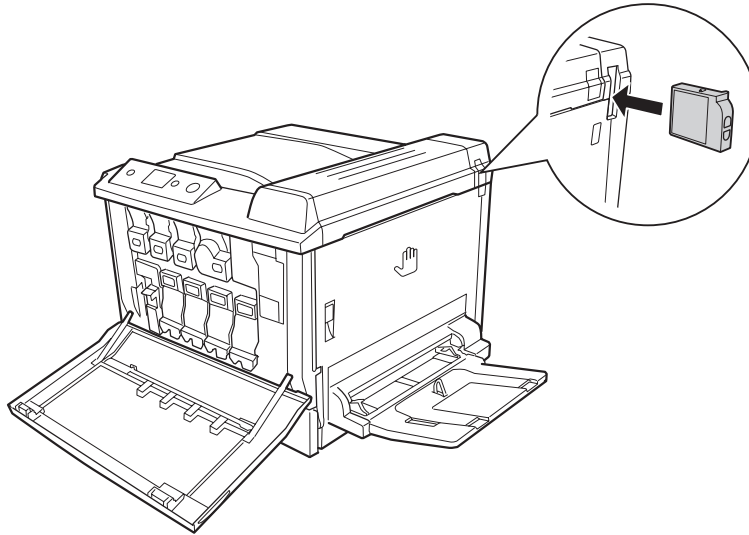

8. Close cover F.

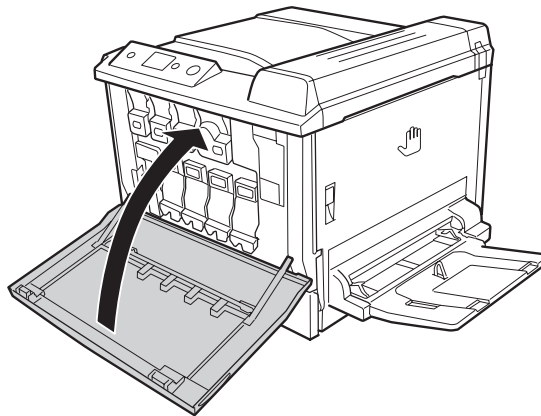

---

## **Photoconductor Unit**

Always observe the following handling precautions when replacing the consumable products:

- When replacing the photoconductor unit, avoid exposing it to room light any longer than necessary.
- Be careful not to scratch the surface of the drum. Also, avoid touching the drum, since oil from your skin may permanently damage its surface and affect print quality.

- ❑ To get the best print quality, do not store the photoconductor unit in an area subject to direct sunlight, dust, salty air, or corrosive gases (such as ammonia). Avoid locations subject to extreme or rapid changes in temperature or humidity.

**Warning:**

- ❑ *Do not dispose of the used consumable products in fire, as it may explode and cause injury. Dispose of it according to local regulations.*
- ❑ *Keep the consumable products out of the reach of children.*

1. Open cover F.

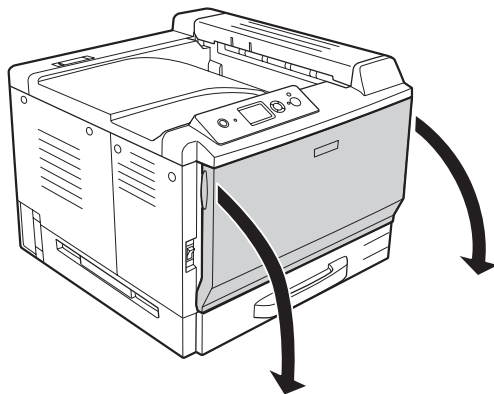

2. Press the projection on the photoconductor unit and slide it out slowly.

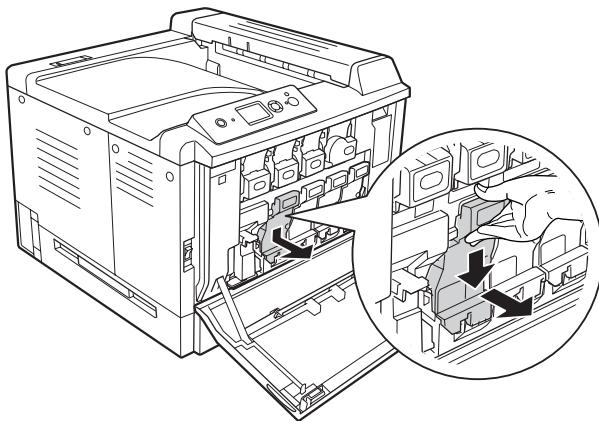

3. Shake the new photoconductor unit a few times gently before taking it out of its package.

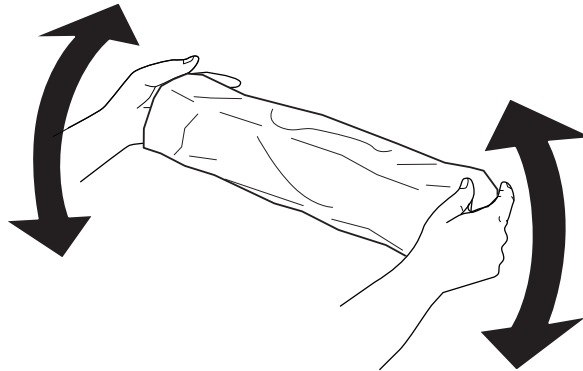

4. Take the new photoconductor unit out of its package.

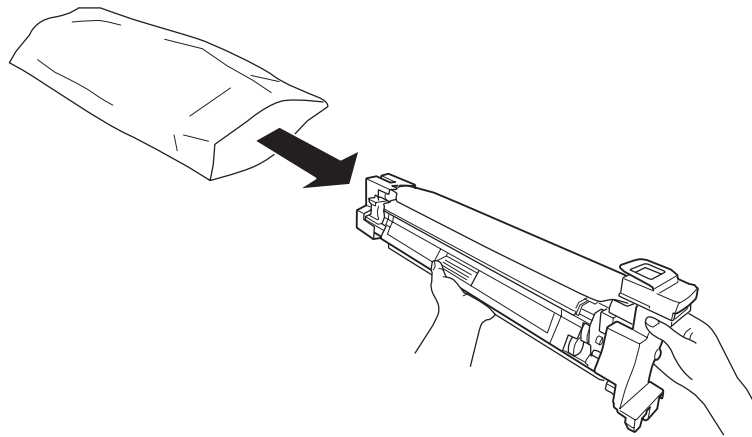

5. Remove the protective materials.

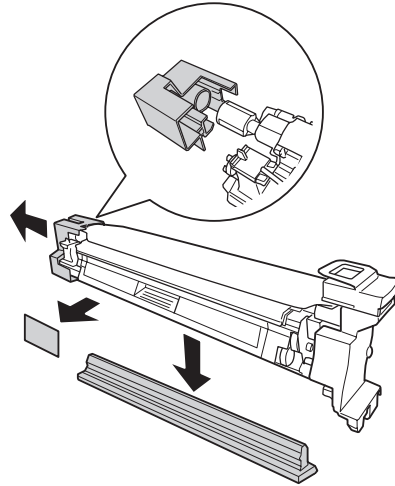
**Caution:**

*Do not remove the protective sheet on the top.*

6. Align the color marks on the photoconductor unit with those of the printer, and then insert the photoconductor unit.

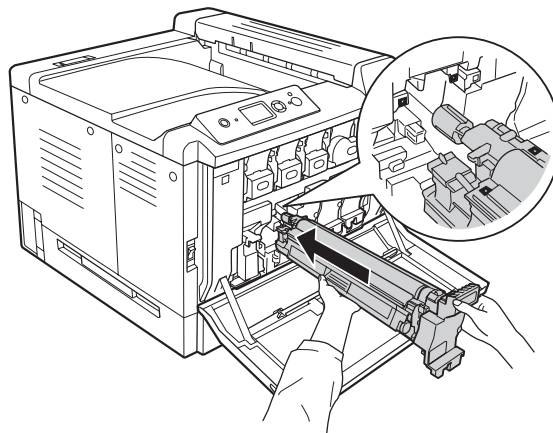
**Note:**

*Insert the photoconductor unit without removing the protective sheet even if it gets wrinkled. If the protective sheet comes off before inserting the photoconductor unit, remove it completely first.*



7. Pull out the protective sheet by the orange handle.

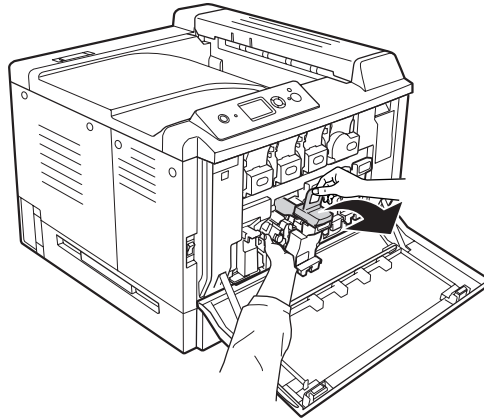

8. Press the photoconductor unit all the way until it locks.

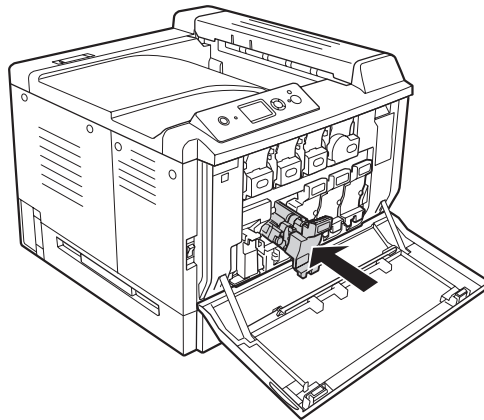

**Caution:**

*Do not scratch the surface of the drum. Also, avoid touching the drum, since oil from your skin may permanently damage its surface and affect print quality.*

9. Close cover F.

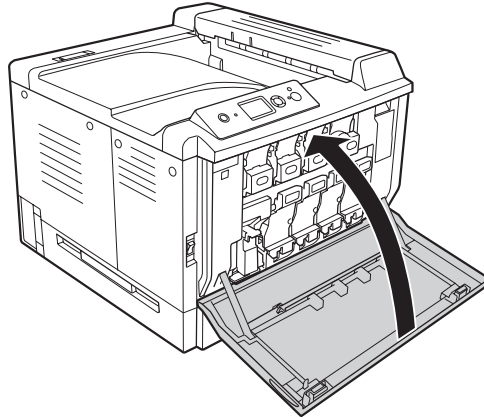

---

## Waste Toner Collector and Filter

Always observe the following handling precautions when replacing the consumable products:

- Do not reuse toner found in the waste toner collector.



**Warning:**

- Do not dispose of the used consumable products in fire, as it may explode and cause injury. Dispose of it according to local regulations.*
- Keep the consumable products out of the reach of children.*

1. Open cover F.

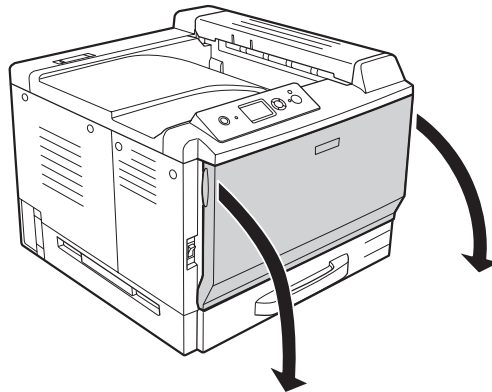

2. Push the release button on the printer, and then pull out the waste toner collector.

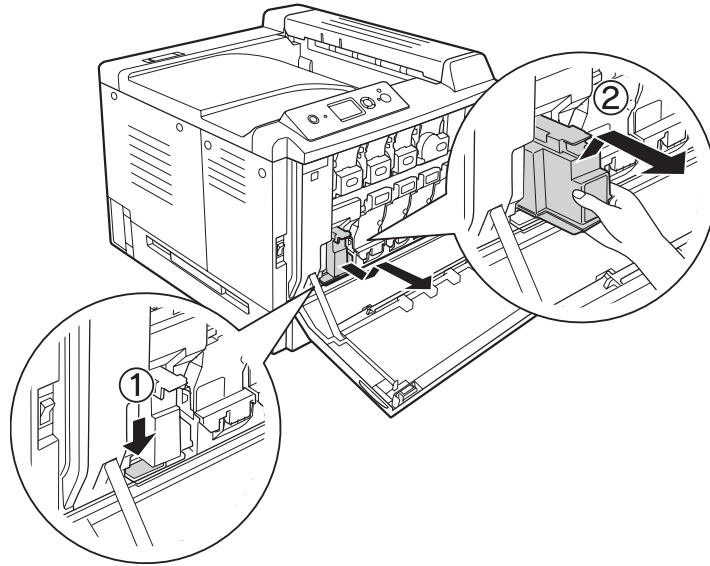
**Caution:**

*To prevent waste toner from spilling, keep the waste toner collector in the same orientation as it was in the printer.*

3. Insert the new waste toner collector all the way until it locks.

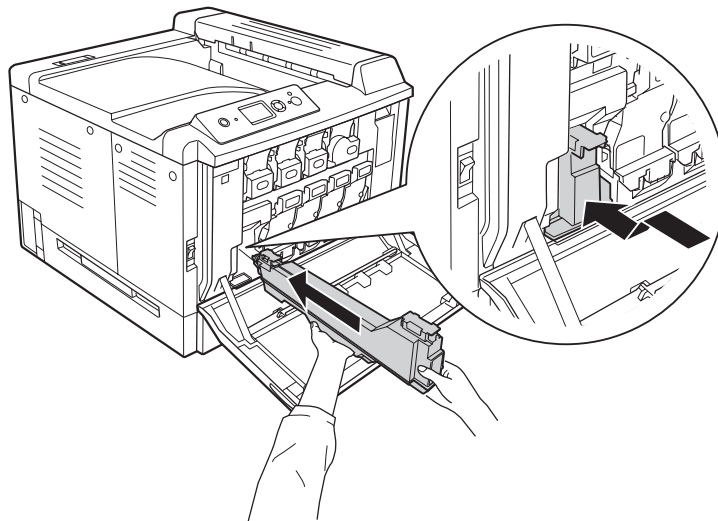

4. Remove the exhaust filter.

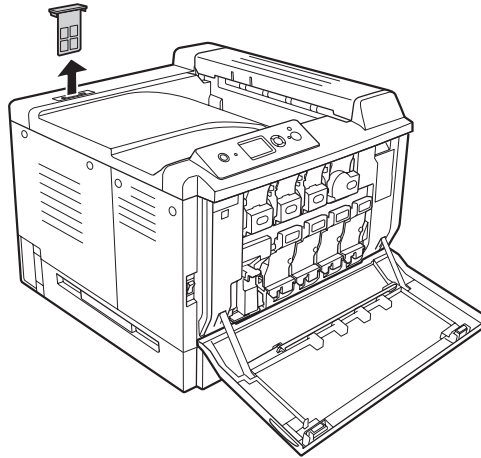

5. Install the new exhaust filter that comes with the waste toner collector.

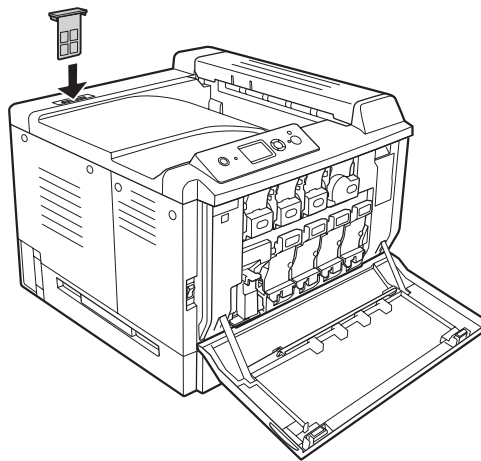

6. Close cover F.

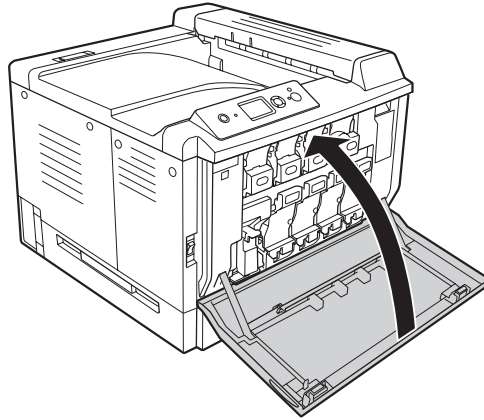

## Chapter 6

# Cleaning and Transporting the Printer

## Cleaning the Printer

The printer needs only minimal cleaning. If the printer's outer case is dirty or dusty, turn off the printer and clean it with a soft, clean cloth moistened with a mild detergent.

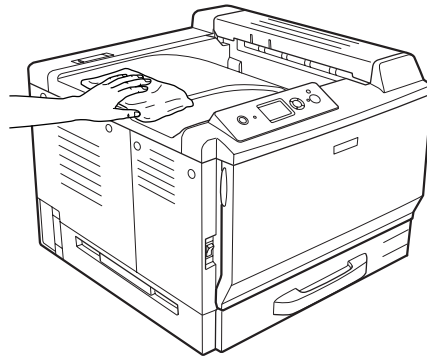

**Caution:**

*Never use alcohol or paint thinner to clean the printer cover. These chemicals can damage the components and the case. Be careful not to get water onto the printer mechanism or any electrical components.*

## Cleaning the pickup roller

Gently wipe the rubber parts of the pick up rollers in the MP tray and standard lower paper cassette with a well-wrung wet cloth.

**MP tray**

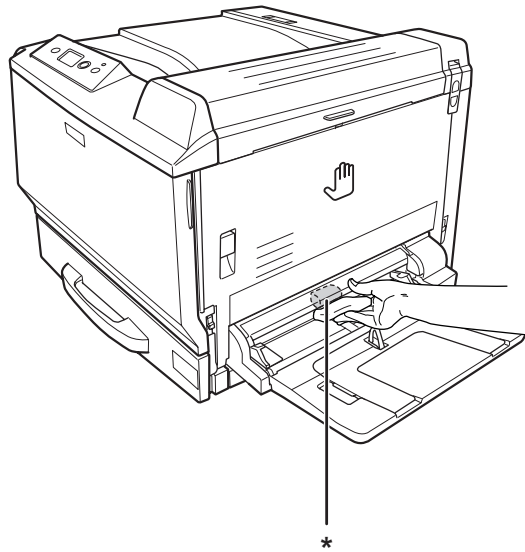

\* pickup roller

**Standard lower paper cassette**

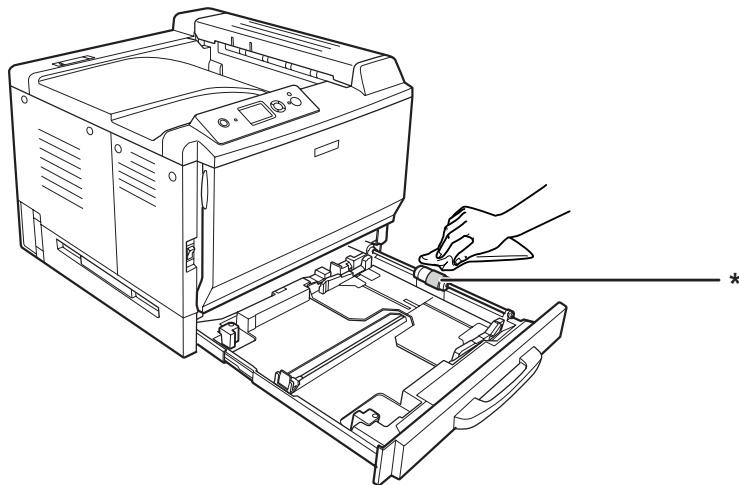

\* pickup roller

## Optional paper cassette unit

**Note:**

The instruction below describes cleaning the pickup rollers using paper cassette 2 as an example.

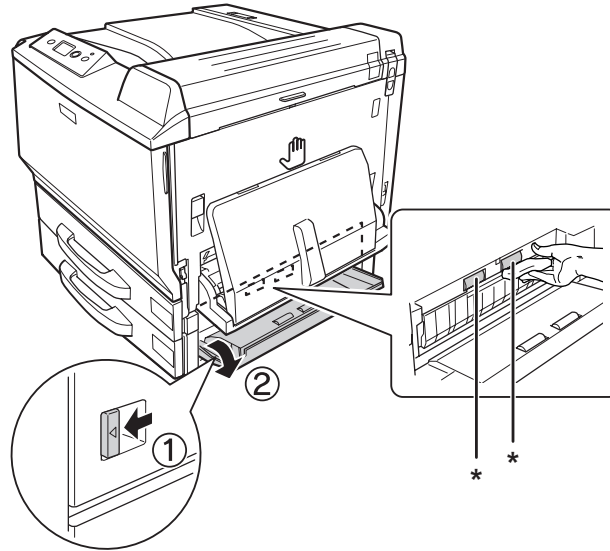

\* pickup roller

## Cleaning the exposure window

1. Open cover F.

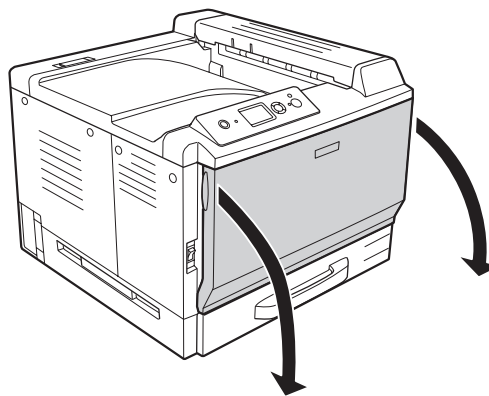



2. Take out the exposure window cleaning bar.

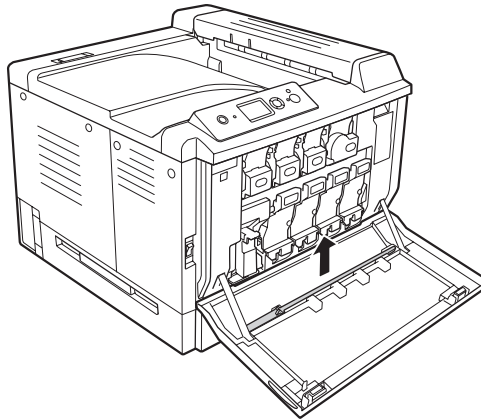

3. Insert the exposure window cleaning bar into the hole under the photoconductor unit with its sponge facing down, and then slide it in and out a few times.

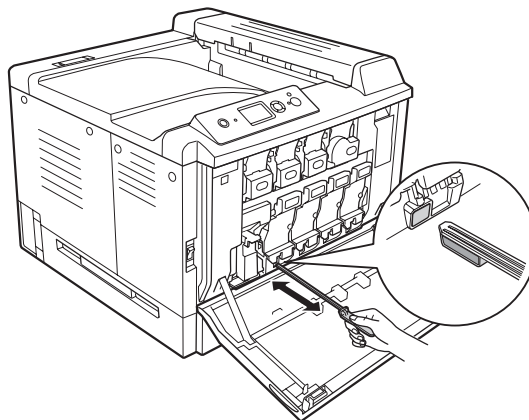

**Note:**

*Repeat the same procedure for the other photoconductor units.*

4. Put the exposure window cleaning bar back in place.

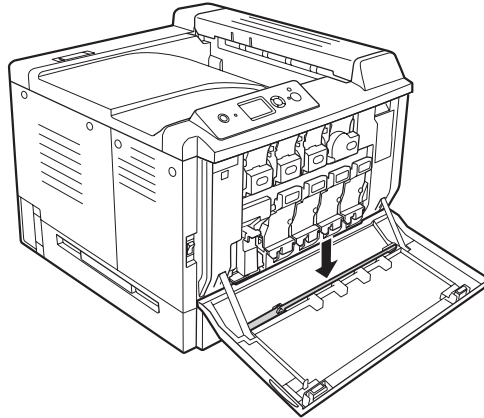

5. Close cover F.

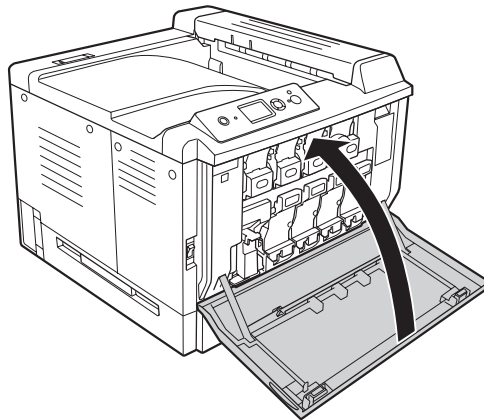

## Transporting the Printer

### Finding a place for the printer

When relocating the printer, always choose a location that has adequate space for easy operation and maintenance. Use the following illustration as a guide for the amount of space required around the printer to ensure smooth operation.

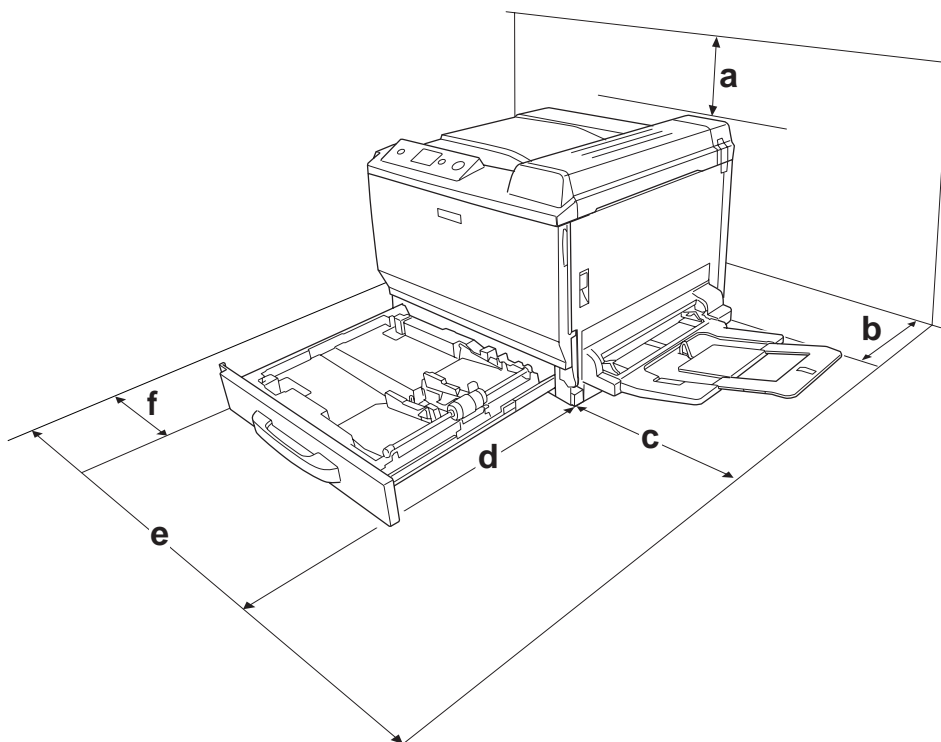

- a. 30 cm
- b. 20 cm
- c. 45 cm
- d. 82 cm
- e. 112.5 cm
- f. 10 cm

To install and use any of the following options, you will need the indicated amount of additional space.

A 500-Sheet Paper Cassette Unit adds 12.4 cm to the bottom of the printer.

A Printer Stand adds 8.9 cm to the bottom of the printer.

In addition to space considerations, always heed the following precautions when finding a place to locate the printer:

- Place the printer where you can easily unplug the power cord.
- Keep the entire computer and printer system away from potential sources of interference, such as loudspeakers or the base units of cordless telephones.
- Avoid using an electrical outlet that is controlled by wall switches or automatic timers. Accidental disruption of power can erase valuable information in your computer's and printer's memory.



**Caution:**

- Leave adequate room around the printer to allow for sufficient ventilation.*
- Avoid locations that are subject to direct sunlight, excessive heat, moisture, or dust.*
- Avoid using outlets that other appliances are plugged into.*
- Use a grounded outlet that matches the printer's power plug. Do not use an adapter plug.*
- Only use an outlet that meets the power requirements for this printer.*

## **For long distances**

### **Repacking the printer**

If you need to transport your printer for long distances, carefully repack it using the original box and packing materials.

1. Turn off the printer and remove the following items:

- Power cord
- Interface cables
- Loaded paper
- Installed options
- Toner cartridges
- Photoconductor units

- Open cover A and cover B, and then push down the release levers at both sides of the fuser unit until they stop.

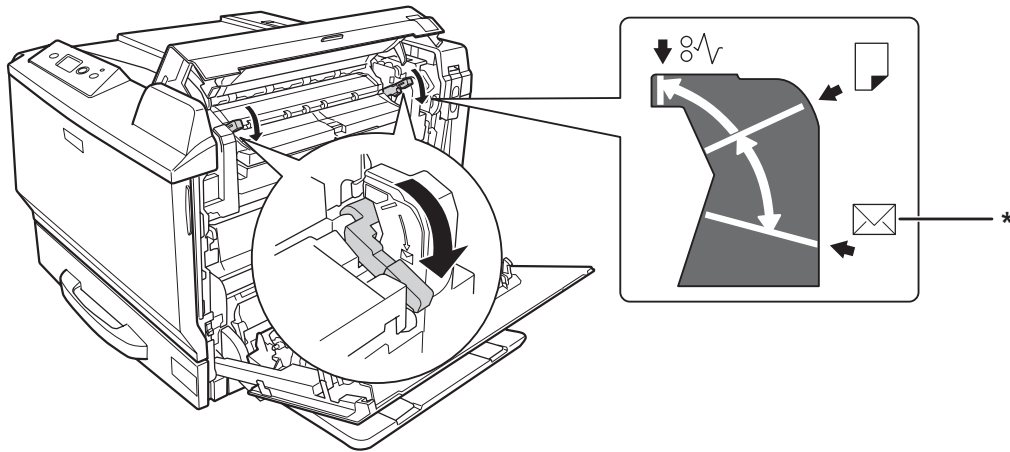

\* envelope position

- Attach the protective materials onto the printer, then repack the printer in its original box.



**Caution:**

*When moving the printer, always keep it horizontal.*

### **For short distances**

Always pay attention to the following handling precautions when you need to move the printer for short distances.

If you are moving the printer on its own, two people should lift and carry the printer.

- Turn off the printer and remove the following items:

- Power cord
- Interface cables
- Loaded paper
- Installed options

2. Be sure to lift the printer by the correct positions as shown below.

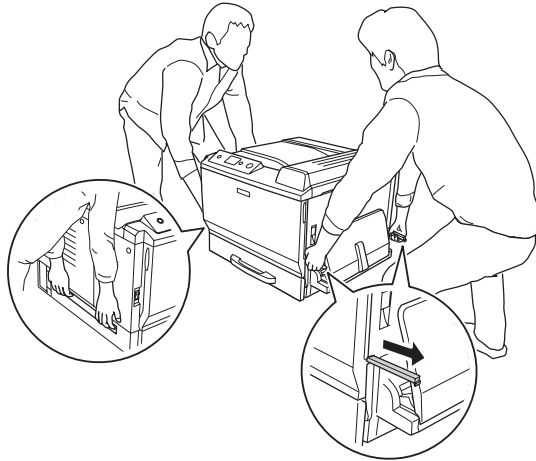
**Caution:**

*When moving the printer, always keep it horizontal.*

## Chapter 7

# Troubleshooting

## Clearing Jammed Paper

If paper becomes jammed in the printer, the printer's LCD panel and EPSON Status Monitor provide alert messages.

### Precautions for clearing jammed paper

Be sure to observe the following points when you clear jammed paper.

- Do not remove jammed paper by force. Torn paper can be difficult to remove and might cause other paper jams. Pull it gently in order to avoid tearing.
- Always try to remove jammed paper with both hands to avoid tearing it.
- If jammed paper is torn and remains in the printer, or if paper is jammed in a place not mentioned in this section, contact your dealer.
- Make sure that the paper type that is loaded is the same as the Paper Type setting in the printer driver.



#### **Warning:**

- Unless specifically instructed in this guide, be careful not to touch the fuser, which is marked **CAUTION HIGH TEMPERATURE**, or the surrounding areas. If the printer has been in use, the fuser and the surrounding areas may be very hot. If you must touch one of these areas, wait 30 minutes to allow the heat to subside before doing so.*
- Do not insert your hand deep into the fuser unit as some components are sharp and may cause injury.*

## Paper Jam A (Cover A)

1. Lift up the unlock lever and open cover A.

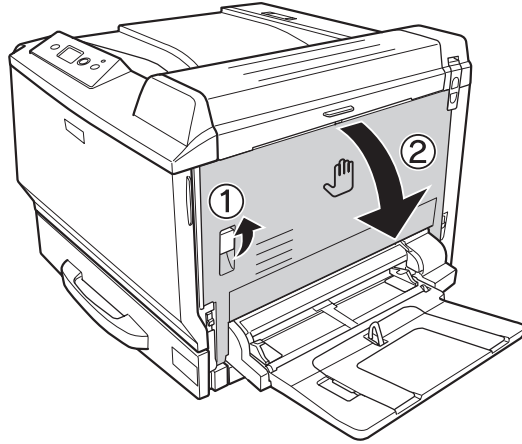

2. If there is any jammed paper, remove it gently with both hands. Be careful not to tear the jammed paper.

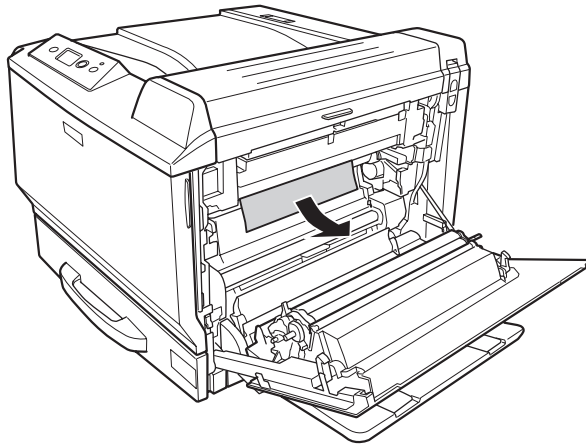

### Note:

- ❑ If the jammed paper cannot be removed, open cover B or cover H. See “Paper Jam B H (Cover B or H)” on page 185.
- ❑ If the jammed paper is not found at cover A, open cover B, cover H, and paper path G to confirm there is no remaining jammed paper. See “Paper Jam B H (Cover B or H)” on page 185 and “Paper Jam G (Paper path G)” on page 192.



3. Close cover A.

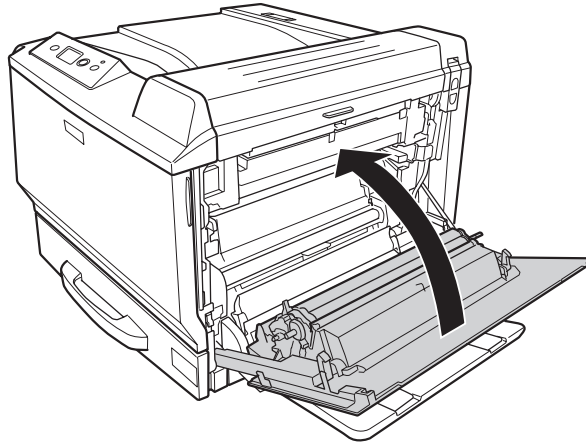

### ***Paper Jam B H (Cover B or H)***

1. Lift up the unlock lever and open cover A.

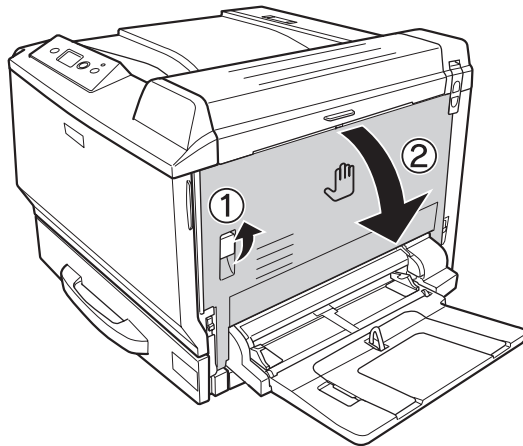

2. Open cover B.

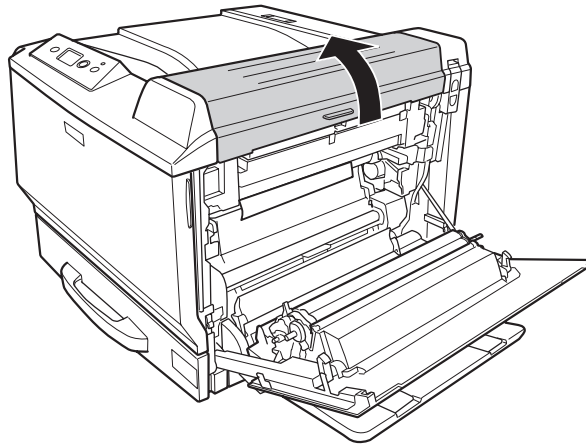

3. Unlock the release levers as shown below.

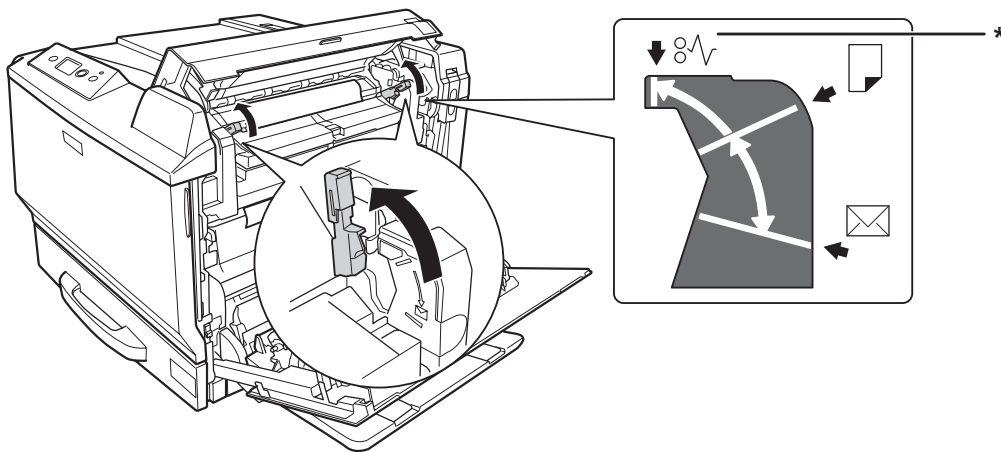

\* release position



**Warning:**

Unless specifically instructed in this guide, be careful not to touch the fuser, which is marked **CAUTION HIGH TEMPERATURE**, or the surrounding areas. If the printer has been in use, the fuser and the surrounding areas may be very hot. If you must touch one of these areas, wait 30 minutes to allow the heat to subside before doing so.

4. If there is any jammed paper, remove it gently with both hands. Be careful not to tear the jammed paper.

When removing paper from the inside:

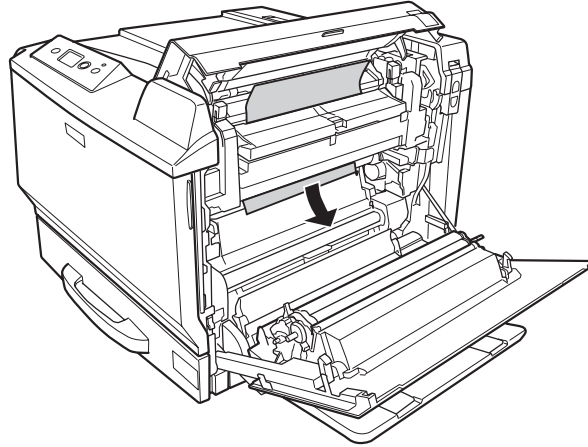

When removing paper from the output tray side:

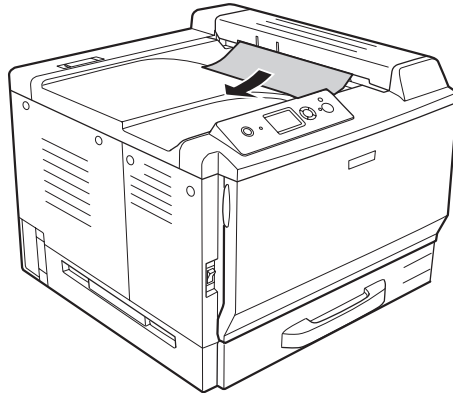

5. Open cover H.

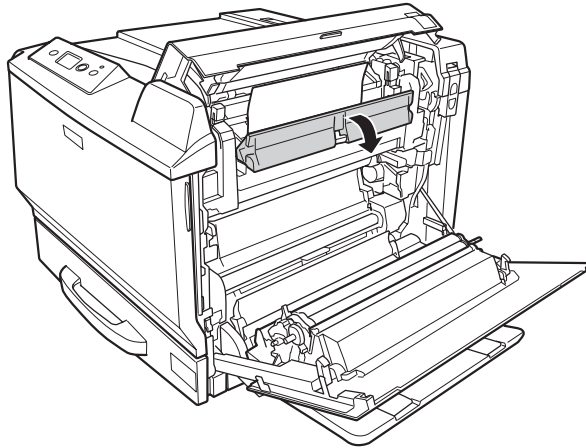

6. If there is any jammed paper, remove it gently with both hands. Be careful not to tear the jammed paper.

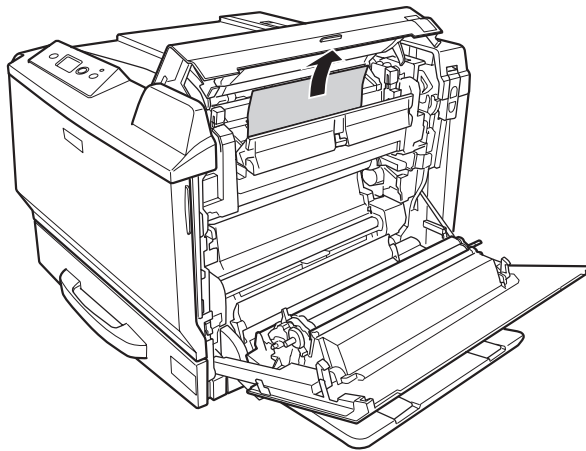

7. Close cover B, and then close cover A.

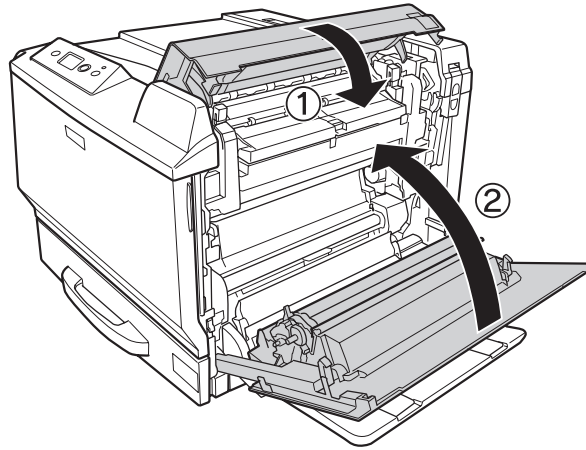

**Note:**

*Release levers return automatically when you close cover B.*

### **Paper Jam D (Duplex Unit cover)**

1. Open the Duplex Unit cover by pulling the handle.

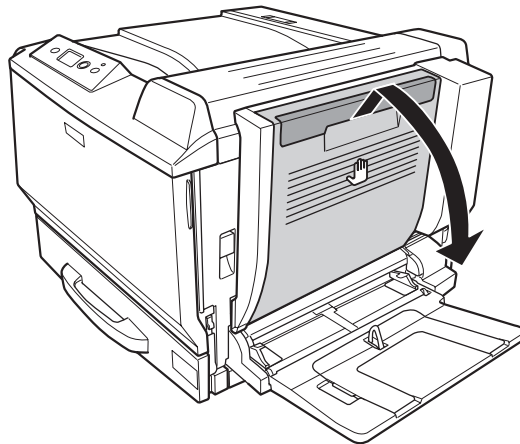

2. Gently remove the jammed paper inside the cover as shown below. Be careful not to tear the paper.

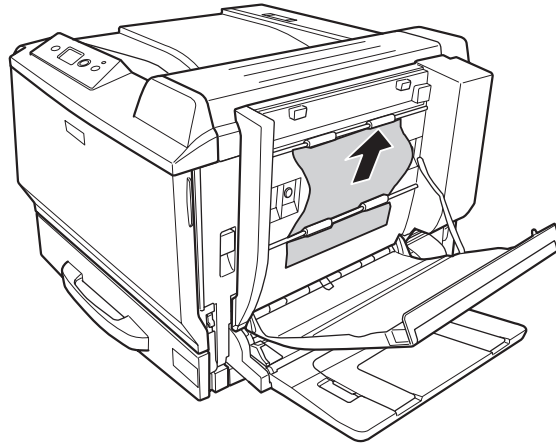

When removing from the bottom:

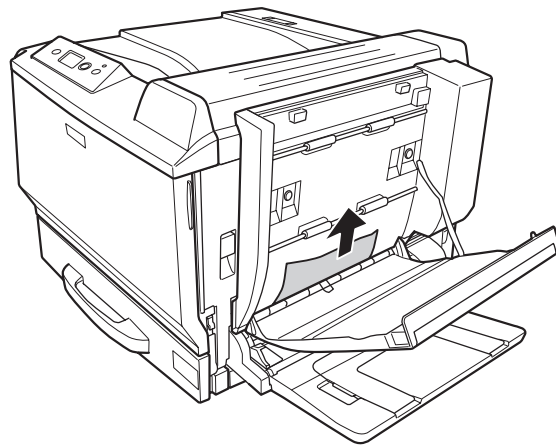

When removing form the top:

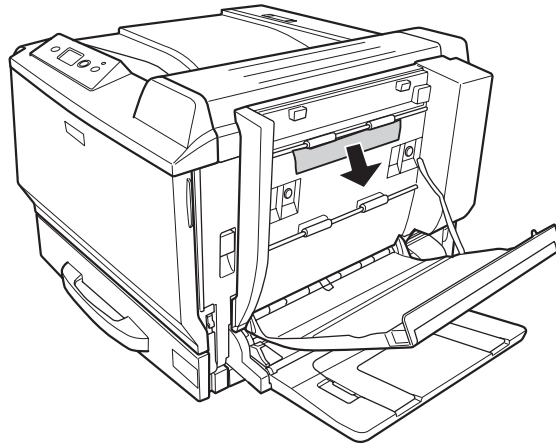

3. Close the Duplex Unit cover.

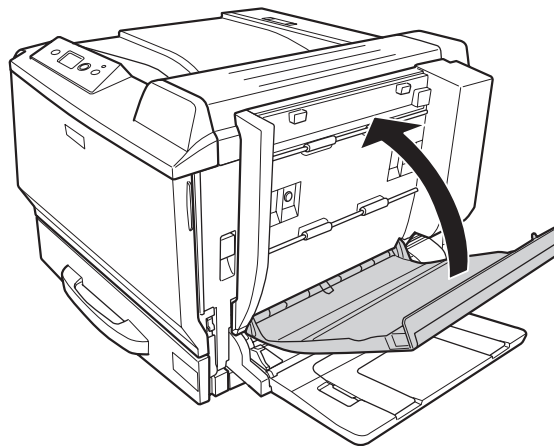

## **Paper Jam G (Paper path G)**

1. Lift up the unlock lever and open cover A.

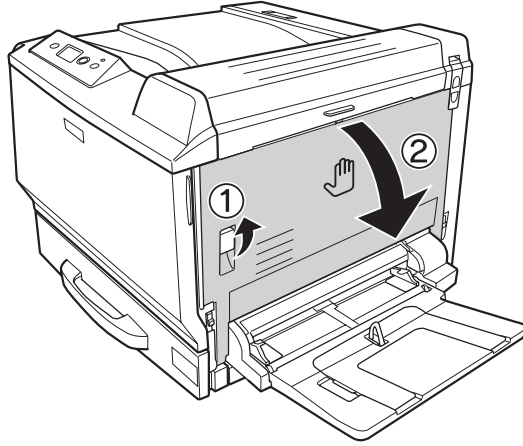

2. Open paper path G.

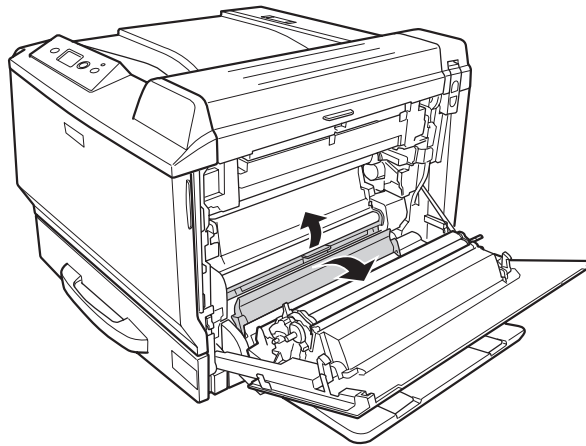



3. If there is any jammed paper, remove it gently. Be careful not to tear the jammed paper.

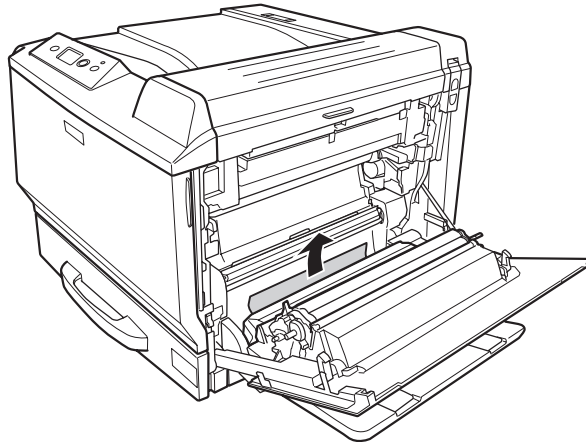

4. Close cover A.

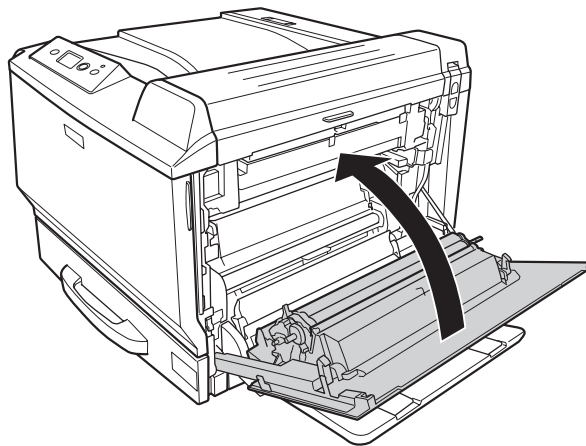

### ***Paper Jam E2, Paper Jam E3, Paper Jam E4 (Cover E2, Cover E3, Cover E4)***

The instruction describes about cover E2 as an example. Use the same procedure for cover E3 and cover E4.

1. Press the unlock lever and open cover E2.

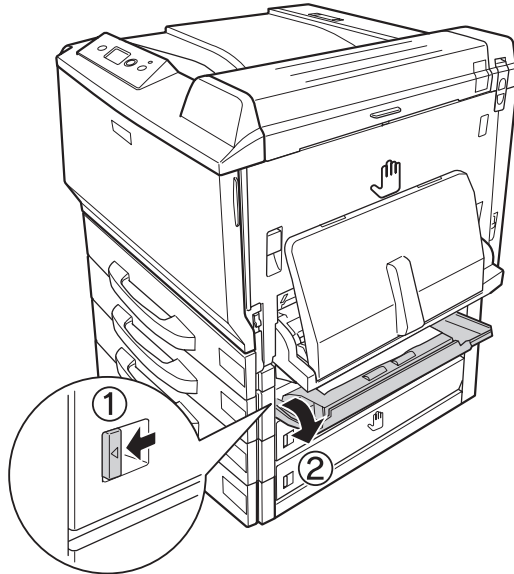

2. Gently remove the jammed paper. Be careful not to tear the paper.

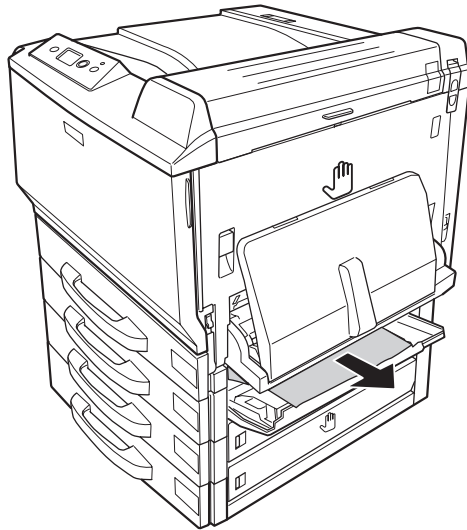

3. Close cover E2.

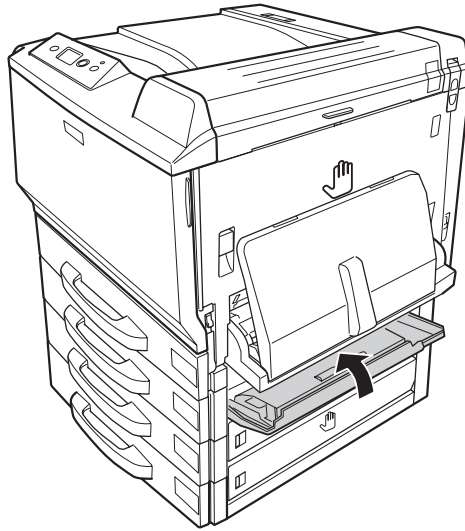

---

## **Printing a Configuration Status Sheet**

To confirm the current status of the printer, and that the options are installed correctly, print a configuration status sheet using the printer's control panel or the printer driver.

To print a configuration status sheet from the printer's control panel, see "Printing a Configuration Status Sheet" on page 121.

To print a configuration status sheet from the printer driver, for Windows, see "Printing a configuration status sheet" on page 217, for Macintosh, see "Printing a configuration status sheet" on page 230.

---

## **Operational Problems**

### ***The Ready light does not turn on***

Cause	What to do
The power cord may not be properly plugged into the electrical outlet.	Turn off the printer, check the power cord connections between the printer and the electrical outlet, then turn the printer back on.

Cause	What to do
The electrical outlet may be controlled by an outside switch or an automatic timer.	Make sure that the switch is turned on or plug another electrical device into the outlet to check whether the outlet is operating properly.

### ***The printer does not print (Ready light off)***

Cause	What to do
The printer is offline.	Press the <b>Start/Stop</b> button once to switch the printer to ready status.
Some error may have occurred.	Check the LCD panel to see if an error message appears.

### ***The Ready light is on but nothing prints***

Cause	What to do
Your computer may not be properly connected to the printer.	Perform the procedure illustrated in the <i>Setup Guide</i> .
The interface cable may not be plugged in securely.	Check both ends of the interface cable between the printer and the computer.
You may not be using the correct interface cable.	If you are using the parallel interface, make sure that the cable is a double-shielded, twisted-pair interface cable no more than six feet in length. If you are using the USB interface, use a Revision 2.0 cable.
Your application software is not properly set up for your printer.	Make sure that the printer is selected in your application software.
Your computer system's memory is too small to handle the volume of data in your document.	Try reducing the image resolution of your document in the application software, or install more memory in your computer if you can.

### ***The optional product is not available***

Cause	What to do
The printer does not recognize the optional product.	Print a configuration status sheet to see if the printer recognizes the optional product. If not, reinstall the optional product.

Cause	What to do
<p>For Windows users, EPSON Status Monitor is not installed.</p> <p>For Macintosh users, you do not re-register the printer.</p>	<p><b>For Windows users:</b> You have to install EPSON Status Monitor, or make settings manually in the printer driver. See "Making Optional Settings" on page 217.</p> <p><b>For Macintosh users:</b> When you have attached or removed options from the printer, you need to start EPSON Status Monitor, or delete and re-register the printer. To delete the printer, use <b>Print &amp; Fax</b> (for Mac OS X 10.5) or <b>Printer Setup Utility</b> (for Mac OS X 10.4 or below). For Mac OS X 10.5 users, you can make the settings manually. Click the <b>Options &amp; Supplies</b> button in Printer &amp; Fax, select the <b>Driver</b> tab, to make the settings manually.</p>

### ***The remaining service life of the consumables is not updated (For Windows users only)***

Cause	What to do
<p>The interval between updating information for the consumables is too long.</p>	<p>Press the <b>Get Information Now</b> button on the Consumable Info Settings dialog box. You can also change the interval for updating information about the consumables on the Consumable Info Settings dialog box.</p>

## ***Printout Problems***

### ***The font cannot be printed***

Cause	What to do
<p>For Windows users, you may use the printer fonts substituted for specified TrueType fonts.</p>	<p>In the printer driver, choose the <b>Print TrueType fonts as bitmap</b> check box in the Extended Settings dialog box.</p>
<p>The selected font is not supported by your printer.</p>	<p>Make sure that you have installed the correct font. See the <i>Font Guide</i> for more information.</p>

## ***Printout is garbled***

<b>Cause</b>	<b>What to do</b>
The interface cable may not be plugged in securely.	Make sure that both ends of the interface cable are plugged in securely.
You may not be using the correct interface cable.	If you are using the parallel interface, make sure that the cable is a double-shielded, twisted-pair interface cable no more than six feet in length.  If you are using the USB interface, use a Revision 2.0 cable.
The emulation setting for the port may not be correct.	Specify the emulation mode by using the printer's control panel menus. See "Emulation Menu" on page 85.

### ***Note:***

*If a configuration status sheet does not print correctly, your printer may be damaged. Contact your dealer or a qualified service representative.*

## ***The printout position is not correct***

<b>Cause</b>	<b>What to do</b>
The page length and margins may be set incorrectly in your application.	Make sure that you are using the correct page length and margin settings in your application.
The Paper Size setting may be incorrect.	Make sure the correct paper size is set in the Tray Menu on the control panel.
The MP Tray Size setting may be incorrect.	When loading paper for which the size is not specified with Auto setting, specify the correct paper size on the MP Tray Size setting in the Tray Menu on the control panel.

## ***Graphics do not print correctly***

<b>Cause</b>	<b>What to do</b>
The printer emulation setting in your application may be incorrect.	Make sure that your application is set for the printer emulation you are using. For example, if you are using the ESC/Page mode, make sure that your application is set to use an ESC/Page printer.
You may need more memory.	Graphics require large amounts of memory. Install an appropriate memory module. See "Memory Module" on page 150.

## Transparencies are output blank from the MP tray

When there are errors while printing on transparencies, the **Check Transparency** error message is displayed on the LCD panel.

Remove the transparencies from the MP tray. Open and close Cover F. Confirm the paper type and size, and then load the correct type of transparencies.

### Note:

- ❑ When using transparencies, load them in the MP tray and set the Paper Type setting to **Transparency** in the printer driver.
- ❑ When the Paper Type setting in the printer driver is set to **Transparency**, do not load any other type of paper except Epson Color Laser Transparencies.

## Color Printing Problems

### Cannot print in color

Cause	What to do
<b>Black</b> is selected as the Color setting in the printer driver.	Change this setting to <b>Color</b> .
The color setting in the application you are using is not appropriate for color printing.	Make sure that the settings in your application are appropriate for color printing.

### The printout color differs when printed from different printers

Cause	What to do
Printer driver default settings and color tables vary by printer model.	Set the Gamma setting to <b>1.8</b> in the More Settings dialog box (for Windows and Mac OS X 10.4 or below) or Color Settings button (for Mac OS X 10.5) in the printer driver, then print again. If you still do not get the printouts you expect, adjust the color using the slide bar for each color. For details about the More Settings dialog box, see the printer driver's online help.

## ***The color looks different from what you see on the computer screen***

<b>Cause</b>	<b>What to do</b>
Printed colors do not exactly match the colors on your monitor, since printers and monitors use different color systems: monitors use RGB (red, green, and blue), while printers typically use CMYK (cyan, magenta, yellow, and black).	Although it is difficult to match colors perfectly, selecting the printer driver's ICM setting (for Windows) or ColorSync setting (for Macintosh) can improve color matching between different devices. For details, see the printer driver's online help.
<b>PhotoEnhance</b> may be selected in the printer driver.	The PhotoEnhance feature corrects the contrast and brightness of the original image data, and so may not be suitable for printing vivid images.

## ***Print Quality Problems***

### ***The background is dark or dirty***

<b>Cause</b>	<b>What to do</b>
You may not be using the correct type of paper for your printer.	If the surface of your paper is too rough, printed characters may appear distorted or broken. Smooth, high-quality copier paper is recommended for best results. See "Available paper types" on page 252 for information on choosing paper.
The paper path inside the printer may be dusty.	Clean internal printer components by printing three pages with only one character per page.

### ***White dots appear in the printout***

<b>Cause</b>	<b>What to do</b>
The paper path inside the printer may be dusty.	Clean internal printer components by printing three pages with only one character per page.

### ***Print quality or tone is uneven***

<b>Cause</b>	<b>What to do</b>
Your paper may be moist or damp.	Do not store paper in a humid or damp environment.



Cause	What to do
One of the toner cartridges may be near the end of its service life.	<p>If the message on the LCD panel or in EPSON Status Monitor indicates that one of the toner cartridges is near the end of its service life, replace the toner cartridge. See "Toner Cartridge" on page 161.</p> <p>For Windows users, you can also check the remaining service life of the toner cartridge by looking at the Basic Settings tab in the printer driver.</p> <p>For Mac OS X 10.5 users, you can check the remaining service life of the toner cartridge by looking at Supply Levels in the printer driver.</p>
There may be a problem with photoconductor units.	Replace the photoconductor units. See "Photoconductor Unit" on page 165.

### ***Half-tone images print unevenly***

Cause	What to do
Your paper may be moist or damp.	Do not store paper in a humid or damp environment. Be sure to use paper that is newly unwrapped.
One of the toner cartridges may be near the end of its service life.	<p>If the message on the LCD panel or in EPSON Status Monitor indicates that one of the toner cartridges is near the end of its service life, replace the toner cartridge. See "Toner Cartridge" on page 161.</p> <p>For Windows users, you can also check the remaining service life of the toner cartridge by looking at the Basic Settings tab in the printer driver.</p> <p>For Mac OS X 10.5 users, you can check the remaining service life of the toner cartridge by looking at Supply Levels in the printer driver.</p>

Cause	What to do
The gradation setting is too small when printing graphics.	<p>For Windows users, on the Basic Settings tab in the printer driver, click the <b>Advanced</b> tab and select the <b>More Settings</b> button. Then select the <b>Halftoning</b>.</p> <p>The setting above is available only when printing in black-and-white and the Monochrome Model Compatibility check box is selected in the printer driver.</p> <p>For Mac OS X 10.5 users, in the Color Settings button in the printer driver, select the <b>Enh.MG</b> check box, then select <b>Smooth</b> from the Adjust Picture drop-down list.</p> <p>For Mac OS X 10.4 or below users, on the Basic Settings tab in the printer driver, click <b>More Settings</b>, select the <b>Enh.MG</b> button, then select <b>Smooth</b> from the Adjust Picture drop-down list.</p>
There may be a problem with photoconductor units.	Replace the photoconductor units. See "Photoconductor Unit" on page 165.

## ***Toner smudges***

Cause	What to do
Your paper may be moist or damp.	Do not store your paper in a humid or damp environment.
You may not be using the correct type of paper for your printer.	EPSON Color Laser Paper or smooth, high-quality copier paper is recommended for best results. See "Available paper types" on page 252 for information on choosing paper.
The paper path inside the printer may be dusty.	Clean internal printer components by printing three pages with only one character per page.
There may be a problem with photoconductor units.	Replace the photoconductor units. See "Photoconductor Unit" on page 165.

## ***Areas are missing in the printed image***

Cause	What to do
Your paper may be moist or damp.	This printer is sensitive to moisture absorbed by the paper. The higher the moisture content in the paper, the lighter the printout. Do not store paper in a humid or damp environment.

Cause	What to do
You may not be using the correct type of paper for your printer.	If the surface of your paper is too rough, printed characters may appear distorted or broken. Smooth, high-quality copier paper is recommended for best results. See "Available paper types" on page 252 for information on choosing paper.

## ***Completely blank pages are output***

Cause	What to do
The printer may have loaded more than one sheet at a time.	Remove the paper stack and fan it. Tap it on a flat surface to even the edges, then reload the paper.
The problem may be with your application or interface cable.	Print out a configuration status sheet. See "Printing a Configuration Status Sheet" on page 195. If a blank page is ejected, the problem may be with the printer. Turn off the printer and contact your dealer.
The Paper Size setting may be incorrect.	Make sure the correct paper size is set in the Tray Menu on the control panel.
The MP Tray Size setting may be incorrect.	When loading paper for which the size is not specified with Auto setting, specify the correct paper size on the MP Tray Size setting in the Tray Menu on the control panel.
One of the toner cartridges may be near the end of its service life.	If the message on the LCD panel or in EPSON Status Monitor indicates that one of the toner cartridges is near the end of its service life, replace the toner cartridge. See "Toner Cartridge" on page 161.  For Windows users, you can also check the remaining service life of the toner cartridge by looking at the Basic Settings tab in the printer driver.  For Mac OS X 10.5 users, you can check the remaining service life of the toner cartridge by looking at Supply Levels in the printer driver.
There may be a problem with photoconductor units.	Replace the photoconductor units. See "Photoconductor Unit" on page 165.

## ***The printed image is light or faint***

Cause	What to do
Your paper may be moist or damp.	Do not store your paper in a humid or damp environment.

Cause	What to do
The Toner Save mode may be on.	<p>Turn off the Toner Save mode using the printer driver or the printer's control panel menus.</p> <p>For Windows users, on the Basic Settings tab in the printer driver, click <b>Advanced</b> and select the <b>More Settings</b> button. Then deselect the <b>Toner Save</b> check box.</p> <p>For Mac OS X 10.5 users, in the Basic Settings button in the printer driver, select the <b>Advanced</b> tab. Then deselect the <b>Toner Save</b> check box.</p> <p>For Mac OS X 10.4 or below users, on the Basic Settings tab in the printer driver, click the <b>Advanced</b> tab and select the <b>More Settings</b> button. Then deselect the <b>Toner Save</b> check box.</p>
One of the toner cartridges may be near the end of its service life.	<p>If the message on the LCD panel or in EPSON Status Monitor indicates that one of the toner cartridges is near the end of its service life, replace the toner cartridge. See "Toner Cartridge" on page 161.</p> <p>For Windows users, you can also check the remaining service life of the toner cartridge by looking at the Basic Settings tab in the printer driver.</p> <p>For Mac OS X 10.5 users, you can check the remaining service life of the toner cartridge by looking at Supply Levels in the printer driver.</p>
There may be a problem with photoconductor units.	Replace the photoconductor units. See "Photoconductor Unit" on page 165.

### ***The non-printed side of the page is dirty***

Cause	What to do
Toner may have spilled onto the paper feed path.	Clean internal printer components by printing three pages with only one character per page.

## ***Print quality decreased***

<b>Cause</b>	<b>What to do</b>
The printer cannot print in the required quality level because of insufficient memory, and the printer lowers the quality automatically so that the printer can continue printing.	<p>Check to see if the printout is acceptable. If not, add more memory for a permanent solution or lower print quality temporarily in the printer driver.</p> <p>If RAM Disk is set to <b>Maximum</b> or <b>Normal</b> on the control panel, you can increase the available memory space by changing this setting to <b>Off</b>.</p>

## ***Memory Problems***

### ***Insufficient memory for current task***

<b>Cause</b>	<b>What to do</b>
The printer has insufficient memory for current task.	<p>Add more memory for a permanent solution or lower print quality temporarily in the printer driver.</p> <p>If RAM Disk is set to <b>Maximum</b> or <b>Normal</b> on the control panel, you can increase the available memory space by changing this setting to <b>Off</b>.</p>

### ***Insufficient memory to print all copies***

<b>Cause</b>	<b>What to do</b>
The printer does not have sufficient memory to collate print jobs.	<p>Only one set of copies will be printed. Reduce the contents of print jobs, or add more memory. For information on installing more memory, see "Memory Module" on page 150.</p> <p>If RAM Disk is set to <b>Maximum</b> or <b>Normal</b> on the control panel, you can increase the available memory space by changing this setting to <b>Off</b>.</p>

## Paper Handling Problems

### Paper does not feed properly

Cause	What to do
The paper guides are not set correctly.	Make sure that the paper guides in all the paper cassettes and the MP tray are set to the correct paper size positions.
The paper source setting may not be correct.	Make sure that you have selected the correct paper source in your application.
There may be no paper in the paper source.	Load paper into the selected paper source.
The size of loaded paper differs from the control panel or printer driver settings.	Make sure that the correct paper size and paper source are set in the control panel or printer driver.
Too many sheets may be loaded in the MP tray or paper cassettes.	Make sure that you have not tried to load too many sheets of paper. For the maximum paper capacity for each paper source, see "General" on page 254.
If paper does not feed from the optional paper cassette unit, the unit may not be installed properly.	For instructions on installing the unit, see "Optional Printer Stand and Paper Cassette Unit" on page 124.
The pickup roller is dirty.	Clean up the pickup roller. For instructions, see "Cleaning the pickup roller" on page 174.
The optional paper cassette may not be installed properly.	See "Optional Printer Stand and Paper Cassette Unit" on page 124 for instructions on installing an optional paper cassette unit.

## Problems Using Options

To confirm your options are installed correctly, print a configuration status sheet. See "Printing a Configuration Status Sheet" on page 195 for details.

### The message *Invalid AUX I/F Card appears on the LCD panel*

Cause	What to do
The printer cannot recognize the installed optional interface card.	Turn off the printer, then remove the card. Make sure the interface card is of a supported model.

## ***Paper does not feed from the optional paper cassette***

<b>Cause</b>	<b>What to do</b>
The paper guides are not set correctly.	Make sure that the paper guides in the optional paper cassettes are set to the correct paper size positions.
The optional paper cassette may not be installed properly.	See "Optional Printer Stand and Paper Cassette Unit" on page 124 for instructions on installing an optional paper cassette unit.
The paper source setting may not be correct.	Make sure you have selected the proper paper source in your application.
There may be no paper in the paper cassette.	Load paper into the selected paper source.
Too many sheets may be loaded in the paper cassette.	Make sure that you have not tried to load too many sheets of paper. For the maximum paper capacity for each paper source, see "MP tray" on page 28, "Standard lower paper cassette" on page 30, and "Optional paper cassette unit" on page 35.
The paper size is not set correctly.	Make sure to set the paper guides in the optional paper cassette correctly.

## ***Feed jam when using the optional paper cassette***

<b>Cause</b>	<b>What to do</b>
The paper is jammed at the optional paper cassette.	See "Clearing Jammed Paper" on page 183 to clear jammed paper.

## ***An installed option cannot be used***

<b>Cause</b>	<b>What to do</b>
The installed option is not defined in the printer driver.	<p><b>For Windows users:</b> You have to make settings manually in the printer driver. See "Making Optional Settings" on page 217.</p> <p><b>For Macintosh users:</b> When you have attached or removed options from the printer, you need to start EPSON Status Monitor, or delete and re-register the printer. To delete the printer, use <b>Print &amp; Fax</b> (for Mac OS X 10.5) or <b>Printer Setup Utility</b> (for Mac OS X 10.4 or below). For Mac OS X 10.5 users, you can make the settings manually. Click the <b>Options &amp; Supplies</b> button in Printer &amp; Fax, select the <b>Driver</b> tab, to make the settings manually.</p>

---

## **Correcting USB Problems**

If you are having difficulty using printer with a USB connection, see if your problem is listed below, and take any recommended actions.

### **USB connections**

USB cables or connections can sometimes be the source of USB problems.

For best results, you should connect the printer directly to the computer's USB port. If you must use multiple USB hubs, we recommend that you connect the printer to the first-tier hub.

### **Windows operating system**

Your computer must be a model pre-installed with Windows Vista, Vista x64, XP, XP x64, 2000, Server 2003, or Server 2003 x64, or a model that was pre-installed with Windows 2000, Server 2003, or Server 2003 x64, and upgraded to Windows Vista, Vista x64, XP or XP x64. You may not be able to install or run the USB printer driver on a computer that does not meet these specifications or that is not equipped with a built-in USB port.

For details about your computer, contact your dealer.

### **Printer software installation**

Incorrect or incomplete software installation can lead to USB problems. Take note of the following and perform the recommended checks to ensure proper installation.

#### **Checking printer software installation**

When using Windows Vista, Vista x64, XP, XP x64, 2000, Server 2003, or Server 2003 x64, you must follow the steps in the *Setup Guide* packed with the printer to install the printer software. Otherwise, Microsoft's Universal driver may be installed instead. To check if the Universal driver has been installed, follow the steps below.

1. Open the **Printers** folder, then right-click the icon of your printer.



2. Click **Printing Preferences** on the shortcut menu that appears, then right-click anywhere in the driver.

If **About** is displayed in the shortcut menu that appears, click it. If a message box with the words “Unidrv Printer Driver” appears, you must reinstall the printer software as described in the *Setup Guide*. If About is not displayed, the printer software has been installed correctly.

**Note:**

*For Windows 2000, if the Digital Signature Not Found dialog box appears during the installation process, click **Yes**. If you click **No**, you will have to install the printer software again.*

*For Windows Vista, Vista x64, XP, XP x64, Server 2003, or Server 2003 x64, if the Software Installation dialog box appears during the installation process, click **Continue Anyway**. If you click **STOP Installation**, you will have to install the printer software again.*

## Network Connection Problems

### Cannot install software or drivers

Cause	What to do
You are not accessing the operating system with the administrator privilege.	Access the operating system with the administrator privilege.

### Cannot access the shared printer

Cause	What to do
Inappropriate texts are used for the Share name of the shared printer.	Do not use spaces or hyphens for the Share name.
An additional driver cannot be installed on the client computer, although the print server's OS and the client OS are different.	Install the printer drivers from the CD-ROM.
Your network system causes this problem.	Ask the administrator of the network for assistance.

**Note:**

*For the additional driver to be installed, please see the table below.*

Server OS	Client OS	Additional Driver
Windows 2000	Windows XP or 2000 clients	Intel Windows 2000
Windows XP*	Windows XP or 2000 clients	Intel Windows 2000 or XP
	Windows XP x64 clients	x64 Windows XP
Windows XP x64, Server 2003, or Server 2003 x64*	Windows XP or 2000 clients	x86 Windows 2000, Windows XP and Windows Server 2003
	Windows XP x64 clients	x64 Windows XP and Windows Server 2003
Windows Vista, Vista x64	Windows Vista, XP, 2000 or Server 2003 clients	x86 Type 3 - User Mode
	Windows Vista x64, XP x64 or Server 2003 x64 clients	x64 Type 3 - User Mode

\* The additional driver for Windows XP x64 and Server 2003 x64 can be used on Windows XP Service Pack 2, Windows 2003 Service Pack 1, or later.

---

## Status and Error Messages

You can see the printer's status and error messages on the LCD panel. For more information, see "Status and Error Messages" on page 106.

---

## Canceling Printing

Press the  **Cancel Job** button on the printer's control panel.

To cancel a print job before it is sent from your computer, see "Cancelling a Print Job" on page 45.

---

## Printing in the PostScript 3 Mode Problems

The problems listed in this section are those that you may encounter when printing with the PostScript driver. All procedural instructions refer to the PostScript printer driver.

## ***The printer does not print correctly in the PostScript mode***

<b>Cause</b>	<b>What to do</b>
The printer's emulation mode setting is incorrect.	The printer is set to the <b>Auto</b> mode by default, so that it can automatically determine the encoding used in the received print job data and select the appropriate emulation mode. However, there are situations where the printer cannot select the correct emulation mode. In this case, it must be set manually to <b>PS3</b> .  Set the emulation mode through the <b>SelectTypeEmulation Menu</b> on the printer. See "Emulation Menu" on page 85.
The printer's emulation mode setting for the interface that you are using is incorrect.	The emulation mode can be set individually for each interface which receives print job data. Set the emulation mode for the interface you are using to <b>PS3</b> .  Set the emulation mode through the <b>SelectTypeEmulation Menu</b> on the printer. See "Emulation Menu" on page 85.

## ***The printer does not print***

<b>Cause</b>	<b>What to do</b>
The <b>Save as File</b> check box is selected on the Output Options sheet in the Print dialog box (for Mac OS X 10.3.9).	Clear the <b>Save as File</b> check box on the Output Options sheet in the Print dialog box.
An incorrect printer driver is selected.	Make sure that the PostScript printer driver that you are using to print is selected.
The <b>Emulation Menu</b> in the printer's Control Panel is set to a mode other than <b>Auto</b> or <b>PS3</b> for the interface that you are using.	Change the mode setting to either <b>Auto</b> or <b>PS3</b> .

## ***The printer driver or printer that you need to use does not appear in the Print & Fax (for Mac OS X 10.5) or Printer Setup Utility (Mac OS X 10.4 or below)***

<b>Cause</b>	<b>What to do</b>
The printer name has been changed.	Ask the network administrator for details, then select the appropriate printer name.
The AppleTalk zone setting is incorrect (for Mac OS X 10.4 or below).	Open the <b>Printer Setup Utility</b> , then select the AppleTalk zone that the printer is connected to.

## ***The font on the printout is different from that on the screen***

<b>Cause</b>	<b>What to do</b>
The PostScript screen fonts are not installed.	The PostScript screen fonts must be installed on the computer that you are using. Otherwise, the font that you select is substituted by some other font for display on the screen.
<b>For Windows users only</b> The appropriate substitution fonts are not correctly specified on the Device Settings sheet of the printer's Properties dialog box.	Specify the appropriate substitution fonts using the Font Substitution Table.

## ***The printer fonts cannot be installed***

<b>Cause</b>	<b>What to do</b>
The Emulation menu in the printer's Control Panel is not set to P <sub>S</sub> 3 for the interface that you are using.	Change the Emulation Menu setting to P <sub>S</sub> 3 for the interface that you are using, then try reinstalling the printer fonts again.

## ***The edges of texts and/or images are not smooth***

<b>Cause</b>	<b>What to do</b>
The Print Quality is set to <b>Fast</b> .	Change the Print Quality setting to <b>Fine</b> .
The printer does not have sufficient memory.	Increase the printer memory.

## ***The printer does not print normally via the USB interface***

<b>Cause</b>	<b>What to do</b>
<b>For Windows users only</b> The Data Format setting in the printer's Properties is not set to <b>ASCII</b> or <b>TBCP</b> .	The printer cannot print binary data when it is connected to the computer via the USB interface. Make sure that the Data Format setting, which is accessed by clicking <b>Advanced</b> on the PostScript sheet of the printer's Properties, is set to <b>ASCII</b> or <b>TBCP</b> .  If your computer is running Windows Vista, Vista x64, XP, XP x64, click the <b>Device Settings</b> tab in the printer's Properties, then click the <b>Output Protocol</b> setting and select <b>ASCII</b> or <b>TBCP</b> .

Cause	What to do
<p><b>For Macintosh users only</b></p> <p>The Data Format setting in the printer's Properties is not set to <b>ASCII</b>.</p>	<p>The printer cannot print binary data when it is connected to the computer via the USB interface. Make sure that the Data Format setting, which is accessed by clicking <b>Print</b> from the File menu, is set to <b>ASCII</b>.</p>

## ***The printer does not print normally via the network interface***

Cause	What to do
<p><b>For Windows users only</b></p> <p>The Data Format setting is different from the data format setting specified in the application.</p>	<p>If the file is created in an application that allows you to change the data format or encoding, such as Photoshop, make sure that the setting in the application matches that in the printer driver.</p>
<p><b>For Windows users only</b></p> <p>The computer is connected to the network using AppleTalk in a Windows 2000 environment, and the <b>Send CTRL+D Before Each Job</b> or <b>Send CTRL+D After Each Job</b> setting on the Device Settings sheet of the printer's Properties dialog box is set to <b>Yes</b>.</p>	<p>Make sure that both the <b>Send CTRL+D Before Each Job</b> and <b>Send CTRL+D After Each Job</b> settings are set to <b>No</b>.</p>
<p><b>For Windows users only</b></p> <p>The print data is too large.</p>	<p>Click <b>Advanced</b> on the PostScript sheet of the printer's Properties, then change the Data Format setting from ASCII data (default) to TBCP (Tagged binary communications protocol).</p> <p>When the Binary setting is set to <input type="checkbox"/>, TBCP is not available. Use the Binary protocol. See "PS3 Menu" on page 97 for details.</p>
<p><b>For Windows users only</b></p> <p>Printing cannot be performed using the network interface.</p>	<p>Click <b>Advanced</b> on the PostScript sheet of the printer's Properties, then change the Data Format setting from ASCII data (default) to TBCP (Tagged binary communications protocol).</p> <p>When the Binary setting is set to <input type="checkbox"/>, TBCP is not available. Use the Binary protocol. See "PS3 Menu" on page 97 for details.</p>

## ***An undefined error occurs (Macintosh only)***

Cause	What to do
<p>The version of the Mac OS that you are using is unsupported.</p>	<p>This printer's driver can only be used on Macintosh computers running Mac OS X version 10.3.9 or later.</p>

## Printing in the PCL5/PCL6 Mode Problems

The problems listed in this section are those that you may encounter when printing in the PCL5/PCL6 mode. All procedural instructions, refer to the PCL5/PCL6 printer driver.

### The printer does not print

Cause	What to do
The Print to file check box is selected in the Print dialog box.	Clear the <b>Print to file</b> check box in the Print dialog box.

### The printer does not print correctly in the PCL mode

Cause	What to do
(PCL5c mode only) <b>Graphics Mode</b> may be set to <b>HP-GL/2</b> and the printing data may include the data that cannot be printed in the setting.	Access the printer driver, click the <b>General</b> tab, click <b>Options</b> , then select <b>Raster as Graphics Mode</b> .
Scaling is done when printing with download fonts.	Access the printer driver, click the <b>General</b> tab, click <b>Options</b> , then select <b>Raster as Graphics Mode</b> . Select <b>None</b> from the TrueType Font Download drop-down list.

### The font on the printout is different from that on the screen

Cause	What to do
The EPSON screen fonts are not installed.	The screen fonts must be installed on the computer that you are using. Otherwise, the font that you select is substituted by some other font for display on the screen.

### The edges of texts and/or images are not smooth

Cause	What to do
The resolution is set to <b>Fast (300 dpi)</b> .	Access the printer driver, click the <b>Print Quality</b> tab, then select <b>Fine (600 dpi)</b> as the resolution.

Cause	What to do
The RITech is set to <b>Off</b> .	Access the printer driver, click the <b>Print Quality</b> tab, then select <b>On</b> for RITech from the drop-down list.

### ***The printer does not print on transparencies***

Cause	What to do
Paper Type is set to <b>Transparency</b> in the printer driver.	Set Enable PJI to <b>Off</b> or access Setup Menu on your printer's control panel, and then set Paper Type to <b>Transparency</b> .

### ***The printer does not print on the specified paper type***

Cause	What to do
Paper Type in the printer driver is set to the type of paper you want to print on.	Set Enable PJI to <b>Off</b> or access Setup Menu on your printer's control panel, and then set Paper Type to the type of paper you want to print on.

### ***The Custom button is grayed out and the custom paper size cannot be created (Windows Vista/Vista x64 only)***

Cause	What to do
After right-clicking your printer icon in the Printers in the Control Panel, you accessed the printer driver from Printing Preferences....	After you right-click your printer icon in the Printers in the Control Panel, select <b>Run as administrator</b> and click <b>Open</b> . Select <b>Printer</b> tab in the screen that appears and then click <b>Printing Preferences</b> ....

### ***The items in the Tray tab/Printer tab are grayed out and these items cannot be changed (Windows Vista/Vista x64 only)***

Cause	What to do
After right-clicking your printer icon in the Printers in the Control Panel, you accessed the printer driver from Properties.	After you right-click your printer icon in the Printers in the Control Panel, select <b>Run as administrator</b> and click <b>Properties</b> .

## Chapter 8

# About the Printer Software for Windows

---

## Using the Printer Driver

---

The printer driver is the software that allows you to adjust printer settings to get the best results.

**Note:**

*The printer driver's online help provides details on printer driver settings.*

**Note for Windows Vista users:**

*Do not press the power button or put your computer to standby or hibernate mode manually during printing.*

## Accessing the printer driver

You can access the printer driver directly from any application programs, and from your Windows operating system.

The printer settings made from any Windows applications override the setting made from the operating system.

### From the application

Click **Print**, **Print Setup**, or **Page Setup** from the File menu. As necessary, click **Setup**, **Options**, **Properties**, or a combination of these buttons.

### Windows Vista users

Click  **Start**, click **Control Panel**, then double-click **Printers**. Right-click your printer's icon, then click **Printing Preferences**.

### Windows XP, Server 2003 users

Click **Start**, click **Printers and Faxes**. Right-click your printer's icon, then click **Printing Preferences**.



### **Windows 2000 users**

Click **Start**, point to **Settings**, then click **Printers**. Right-click your printer's icon, then click **Printing Preferences**.

### **Printing a configuration status sheet**

To confirm the current status of the printer, print a configuration status sheet from the printer driver.

**Note:**

*Print the configuration status sheet on A4 size paper.*

1. Access the printer driver.
2. Click the **Optional Settings** tab and then click **Configuration** in Print Status Sheets.

### **Making Extended Settings**

You can make various settings in the Extended Settings dialog box. To open the dialog box, click **Extended Settings** on the Optional Settings tab.

### **Making Optional Settings**

You can update the installed option information manually if you have installed options to your printer.

1. Access the printer driver.
2. Click the **Optional Settings** tab, then select **Update the Printer Option Info Manually**.
3. Click **Settings**. The Optional Settings dialog box appears.
4. Make settings for each installed option, then click **OK**.

### **Displaying consumable information**

The remaining service life of the consumables is displayed on the Basic Settings tab.

**Note:**

- ❑ *This function is available only when EPSON Status Monitor is installed.*
- ❑ *This information might be different from the information displayed in EPSON Status Monitor. Use EPSON Status Monitor to get more detailed information about consumables.*
- ❑ *If the genuine consumables are not used, the level indicator and the alert icon showing the remaining service life are not displayed.*

## Ordering Consumables

Click the **Order Online** button on the Basic Settings tab. See “Order Online” on page 227 for details.

**Note:**

*This function is available only when EPSON Status Monitor is installed.*

---

## Using EPSON Status Monitor

EPSON Status Monitor is a utility program that monitors your printer and gives you information about its current status.

## Installing EPSON Status Monitor

1. Make sure that the printer is off and that Windows is running on your computer.
2. Insert the printer software CD-ROM in the CD-ROM drive.

**Note:**

- ❑ *If the Epson Installation Program screen does not appear automatically, click  **Start**, then click **Computer** (for Windows Vista) or click the **My Computer** icon on the desktop (for Windows XP, 2000 or Server 2003). Right-click the CD-ROM icon, click **Open** in the menu that appears, then double-click **Epsetup.exe**.*
- ❑ *If the language selection window appears, select your country.*

3. Click **Custom Install**.



**Note:**

- See the Network Guide for information on installing EPSON Status Monitor on a network.
  - If you want to use the printer via the print server, you have to install EPSON Status Monitor from the CD-ROM with administrator privileges in each client.
4. Click **EPSON Status Monitor**.
  5. Read the license agreement statement, then click **Accept**.
  6. Select your country or region, then click **OK**. EPSON Web site is registered.

**Note:**

- Be sure to register the Web site to order consumables online.
  - If you click the **Cancel** button, the Web site is not registered, but the EPSON Status Monitor installation continues.
7. When the installation is complete, click **OK**.

## Accessing EPSON Status Monitor

Right-click the EPSON Status Monitor tray icon on the taskbar, then select the printer name and menu you want to access.



**Note:**

- ❑ You can also access EPSON Status Monitor by clicking the **Simple Status** button on the *Optional Settings* tab on the printer driver.
- ❑ The *Order Online* dialog box also appears by clicking the **Order Online** button on the *Basic Settings* tab in the printer driver.

About	You can obtain information about EPSON Status Monitor such as product versions or interface versions.
Simple Status	You can check printer status, errors, and warnings.
Detailed Status*	You can monitor detailed printer status. When a problem occurs, the most probable solution is displayed. See “Detailed Status” on page 221.
Replacement Parts Information*	You can obtain information on paper sources and replacement parts. See “Replacement Parts Information” on page 222.
Job Information*	You can check print job information. See “Job Information” on page 223.
Notice Settings	You can make specific monitoring settings. See “Notice Settings” on page 225.
Order Online	You can order consumables online. See “Order Online” on page 227.
Tray Icon Settings	You can set the information to display when the Tray icon is double-clicked while there are no jobs sent from the computer.

\* You can also access any of the menus by clicking the appropriate tab on each information window.

**Note for Windows Vista users:**

*EPSON Status Monitor is not available for monitoring Netware printers.*

**Note for Windows XP users:**

EPSON Status Monitor is not available when printing from a Remote Desktop connection.

**Note for NetWare users:**

When monitoring NetWare printers, a Novell Client that corresponds to your operating system must be used. Operation is confirmed for the versions below:

- For Windows XP or 2000:  
Novell Client 4.91 SP1 for Windows 2000/XP
- To monitor a NetWare printer, connect only one print server to each queue. For directions, see the Network Guide for the printer.
- You cannot monitor a NetWare queue printer beyond the IPX router because the setting for IPX hops is 0.
- This product supports NetWare printers configured by a queue-based printing system such as Bindery or NDS. You cannot monitor NDPS (Novell Distributed Print Services) printers.



## Detailed Status

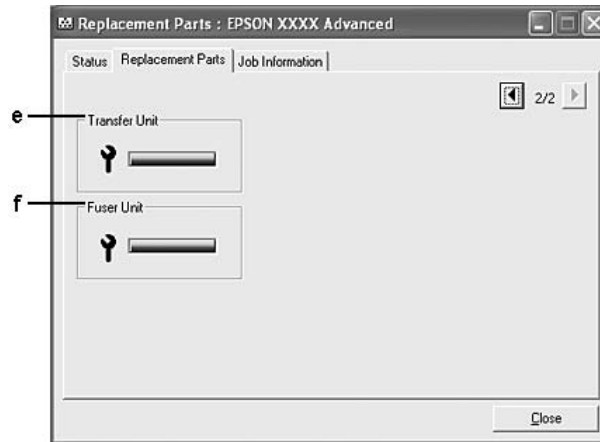
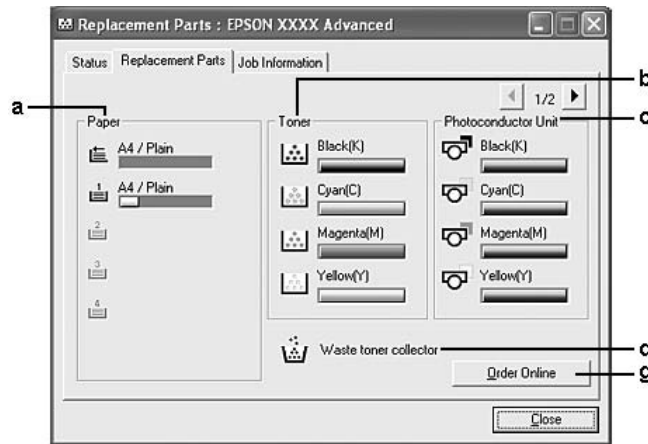

## Replacement Parts Information



**Note:**

To change the two windows above, click  or .

a.	Paper:	Displays the paper size, the paper type and the approximate amount of paper remaining in the paper source. The paper cassette icon flashes when the amount of paper remaining in the paper cassette is low.
b.	Toner:	Indicates the remaining service life of the toner cartridges. The toner icon flashes when the toner cartridge has some error or has neared the end of its service life.
c.	Photoconductor Unit:	Indicates the remaining service life of the photoconductor units. The photoconductor unit icon flashes when the photoconductor unit has some error or has neared the end of its service life.
d.	Waste toner collector:	The waste toner collector icon flashes when the waste toner collector has some error or has neared the end of its service life.

e.	Transfer Unit:	Indicates the remaining service life of the transfer unit. The service icon flashes when the transfer unit has some error or has neared the end of its service life.
f.	Fuser Unit:	Indicates the remaining service life of the fuser unit. The service icon flashes when the fuser unit has some error or has neared the end of its service life.
g.	Order Online button:	Clicking this button enables you to order consumables online. See "Order Online" on page 227 for details.

**Note:**

The remaining service lives of the replacement parts are displayed only if genuine EPSON parts are used.

**Job Information**

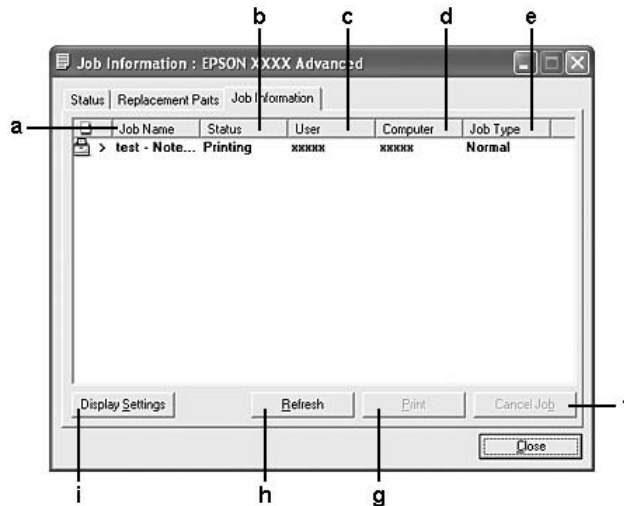

a.	Job Name:	Displays the user's print job names. Other user's print jobs are displayed as -----.	
b.	Status:	Waiting:	Indicates the print job is waiting to be printed.
		Spooling:	Indicates the print job is being spooled on your computer.
		Deleting:	Indicates the print job is being deleted.
		Printing:	Indicates the print job is printed currently.
		Completed:	Indicates the print job have finished.
		Canceled:	Indicates the print job have been canceled.
		Held:	Indicates the print job is on hold.

c.	User:	Displays the user name.
d.	Computer:	Displays the name of the computer that sent the print job.
e.	Job Type:	Displays the job type. The jobs are displayed as Stored, Verify, Re-Print, and Confidential respectively. About the Reserve Job function, see "Using the Reserve Job Function" on page 76.
f.	Cancel Job button:	Cancels the selected print job.
g.	Print button:	Prints the held status job.
h.	Refresh button:	Refreshes the information on this menu.
i.	Display settings button:	Displays the Display Settings dialog box to select items and the order they are displayed on the Job Information screen and to select the type of jobs to be displayed.

**Note for Windows XP users:**

*Shared Windows XP LPR connections and shared Windows XP Standard TCP/IP connections with Windows clients do not support the Job Management function.*

The **Job Information** tab is available when the following connections are used:

**Server and Client Environments:**

- When using the shared Windows 2000, Server 2003, or Server 2003 x64 LPR connection with Windows Vista, Vista x64, XP, XP x64, or 2000 clients.
- When using the shared Windows Vista, Vista x64, 2000, Server 2003, or Server 2003 x64 Standard TCP/IP connection with Windows Vista, Vista x64, XP, XP x64, or 2000.
- When using the shared Windows Vista, Vista x64, 2000, Server 2003, or Server 2003 x64 EpsonNet Print TCP/IP connection with Windows Vista, Vista x64, XP, XP x64, or 2000 clients.

**Client only Environments:**

- When using the LPR connection (in Windows Vista, Vista x64, XP, XP x64, 2000, Server 2003, or Server 2003 x64).
- When using the Standard TCP/IP connection (in Windows Vista, Vista x64, XP, XP x64, 2000, Server 2003, or Server 2003 x64).
- When using the EpsonNet Print TCP/IP connection (in Windows Vista, Vista x64, XP, XP x64, 2000, Server 2003, or Server 2003 x64).



**Note:**

You cannot use this function in the following situations:

- ❑ When using an optional Ethernet interface card that does not support the job management function.
- ❑ When the NetWare connections do not support the job management function.
- ❑ When the printing jobs from NetWare and NetBEUI are displayed as “Unknown” on the Job Management menu.
- ❑ Note that if the user account used to log on to a client is different from the user account used to connect to the server, the job management function is not available.

**Notice Settings**

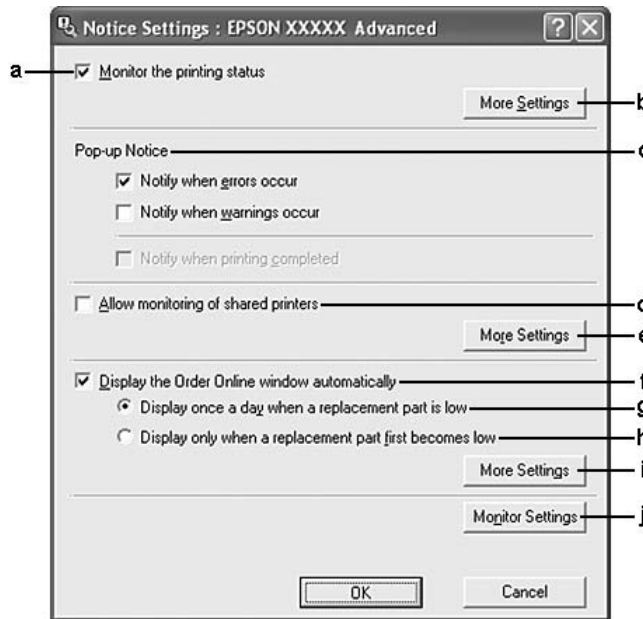

a.	Monitor the printing status check box:	When this check box is selected, EPSON Status Monitor monitors the printer status during a print job is processed.
b.	More Settings button:	Opens the More Settings dialog box to set how to display the tray icon.
c.	Pop-up Notice:	Sets the notification to be displayed.

d.	Allow monitoring of shared printers check box:	When this check box is selected, a shared printer can be monitored by other computers.  If you connect the printer via a server with Windows Point & Print and the server and the client are both Windows XP or later, it communicates with the OS communication function. Therefore you can monitor the printer without selecting this check box.
e.	More Settings button:	Opens the More Settings dialog box to set how to communicate with the shared printer.
f.	Display the Order Online window automatically check box:	When this check box is selected, the Order Online window appears automatically when a consumable becomes low or reaches end of service life.
g.	Display once a day when a replacement part is low check box:	When this radio button is selected, the Order Online window appears automatically once a day when you start printing or display the status by accessing EPSON Status Monitor.
h.	Display only when a replacement part first becomes low check box:	When this radio box is selected, the Order Online window appears automatically only when a replacement part first becomes low.
i.	More Settings button:	Opens the More Settings dialog box in which you can set the URL for placing an order appears.
j.	Monitor Settings button:	Opens the Monitor Settings dialog box to set the monitoring interval.

**Note for Windows Vista users:**

When **Allow monitoring of the shared printers** check box is selected, the User Account Control dialog box will appear. Then click **Continue** to make the settings.

**Note:**

When sharing the printer, be sure to set EPSON Status Monitor so that the shared printer can be monitored on the print server.

## Order Online

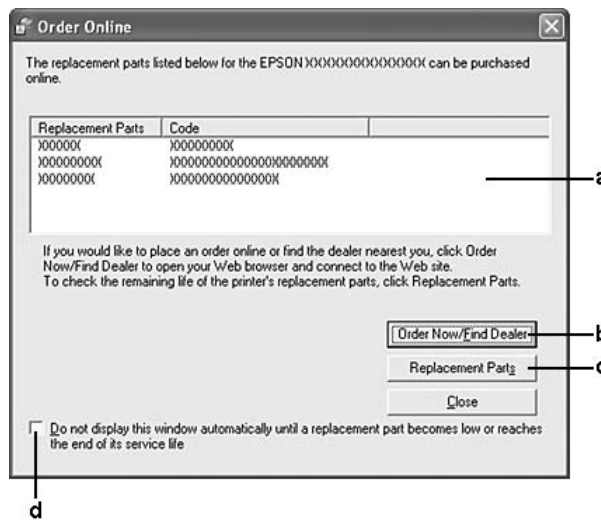

a.	Text box:	Displays the consumables and codes.
b.	Order Now/Find Dealer button:	Connects to the URL where you can place an order and find the dealer nearest you.  If you do not want a confirmation message, select the <b>Do not display the confirmation message before connecting</b> check box in the More Settings dialog box. The More Setting dialog box appears by clicking the <b>More Settings</b> button in the Notice Settings dialog box.
c.	Replacement Parts button:	Displays the replacement parts information.
d.	Do not display this window automatically until a replacement part becomes low or reaches the end of its service life check box:	When this check box is selected, the Order Online window appears automatically only when a replacement part first becomes low or reaches end of service life.

### Note for Windows users:

If you do not register the URL when you install EPSON Status Monitor, you cannot order online. If necessary, uninstall EPSON Status Monitor once, then register the URL when you reinstall it.

## Uninstalling the Printer Software

### Note:

The illustrations in this section show Windows XP screens. They may be different from the screens for your operating system.

1. Quit all applications.
2. For Windows Vista, click  **Start**, then click **Control Panel**.  
For Windows XP, XP x64, Server 2003, or Server 2003 x64, click **Start**, click **Control Panel**, then click **Add or Remove Programs**.  
For Windows 2000, click **Start**, point to **Settings**, then click **Control Panel**.
3. For Windows Vista, double-click the **Programs and Features** icon.  
For Windows XP, XP x64, Server 2003, or Server 2003 x64, click the **Change or Remove Programs** icon.  
For Windows 2000, double-click the **Add/Remove Programs** icon.
4. For Windows Vista, select **EPSON Printer Software**, then click **Uninstall/Change**.  
For Windows XP, XP x64, 2000, Server 2003, or Server 2003 x64, select **EPSON Printer Software**, then click **Change/Remove**.

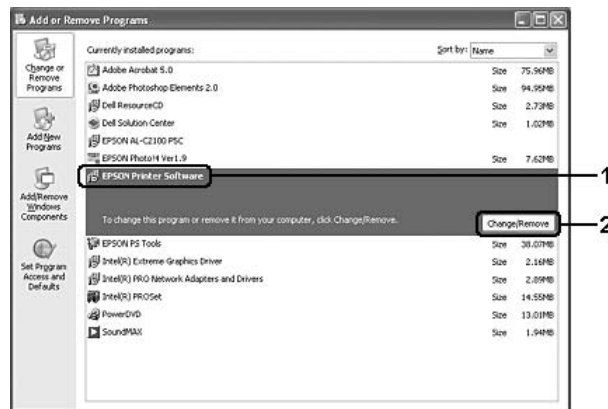

5. Click the **Printer Model** tab, select your printer's icon.

6. If you wish to uninstall only a utility, click the **Utilities** tab, and select the check box for the printer software you want to uninstall.

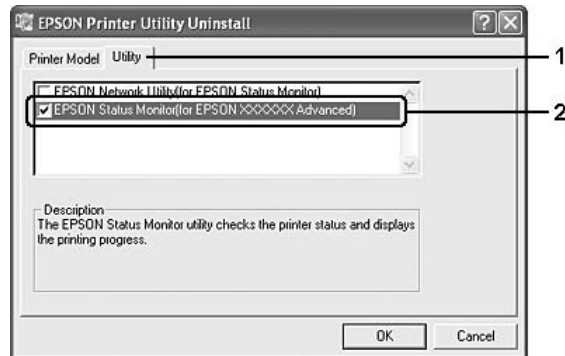

7. Click **OK**.

**Note:**

*You can uninstall EPSON Network Utility. When the utility is uninstalled, you cannot display the printer status from EPSON Status Monitor of other printers.*

8. Follow the on-screen instructions.

## Chapter 9

# About the Printer Software for Macintosh

## Using the Printer Driver

The printer driver is the software that allows you to adjust printer settings to get the best results.

**Note:**

- ❑ *The printer driver's online help provides details on printer driver settings.*
- ❑ *You have to re-install the printer driver after updating the operating system from OS X 10.3.9 to 10.4.*

## Accessing the printer driver

You can access the printer driver directly from any application programs, and from your operating system.

### From an operating system

Register your printer in **Print & Fax** (for Mac OS X 10.5) or **Printer Setup Utility** (for Mac OS X 10.4 or below), click **Print** on the File menu of any application, then select your printer.

### From an application

- ❑ To set the paper size, select **Page Setup** or **Print** from the File menu on any application.
- ❑ To open the Printer Settings, select **Print** from the File menu on any application.

## Printing a configuration status sheet

To confirm the current status of the printer, print a configuration status sheet from the printer driver.

1. Click the **EPSONRemotePanel** icon from Dock.
2. Select your printer in the EPSONRemoteControlPanel dialog box.
3. Click **Status Sheet**, and then click **Configuration**.

**Note for Mac OS X 10.4 or below users:**

To access EPSON Remote Control Panel from Dock for the first time after installing the printer driver, you need to open the print dialog box first.

## Changing the Printer Settings

You can change the printer settings, such as paper source, paper type, and print quality.

Open the Print dialog box and select **Printer Settings** from the drop-down list, then select the **Basic Settings** button (for Mac OS X 10.5) or **Basic Settings** tab (for Mac OS X 10.4 or below).

## Making Extended Settings

You can make various settings in the Extended Settings dialog box, for example Skip Blank Page.

Open the Print dialog box and select **Printer Settings** from the drop-down list, then select the **Extended Settings** button (for Mac OS X 10.5) or **Extended Settings** tab (for Mac OS X 10.4 or below).

---

## Using EPSON Status Monitor

EPSON Status Monitor is a utility program that monitors your printer and gives you information about its current status.

## Accessing EPSON Status Monitor

For Mac OS X 10.5 users

1. Open System Preferences, and then double-click the **Print & Fax** icon.
2. Select your printer from the Printers list and click **Open Print Queue**.

3. Click the **Utility** icon.

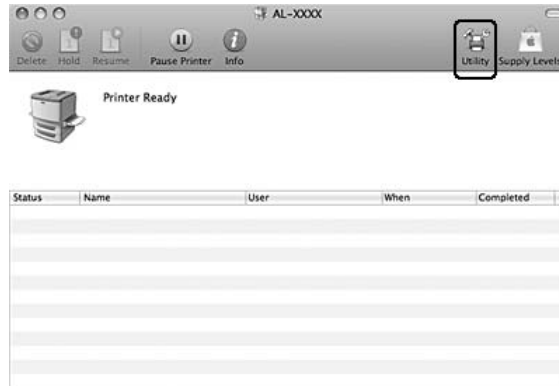

**For Mac OS X 10.4 or below users**

**Note:**

After installing the EPSON Status Monitor and before doing the procedure below, you need to open the Print dialog box so the EPSON Status Monitor can display the current status of the printer.

1. Open the Applications folder on your hard disk drive, then open the Utilities folder.
2. Double-click the **Printer Setup Utility** icon.
3. Double-click your printer from the Name list.
4. Click the **Utility** icon.



**Note:**

You can also access EPSON Status Monitor by clicking the **EPSON Status Monitor** icon in the Dock.

Simple Status	You can check the type of errors and a possible solution. This window appears when an error or warning occurs, and closes automatically once the problem is cleared.
---------------	--



Detailed Status*	You can monitor detailed printer status. When a problem occurs, the most probable solution is displayed. See "Detailed Status" on page 233.
Replacement Parts Information*	You can obtain information on paper sources and consumable products. See "Replacement Parts Information" on page 234.
Job Information*	You can check print job information. See "Job Information" on page 235.
Notice Settings	You can make specific monitoring settings. Access EPSON Status Monitor and select Notice Settings from the file menu. See "Notice Settings" on page 236.

\* You can also access any of the menus by clicking the appropriate tab on each information window.

## Detailed Status

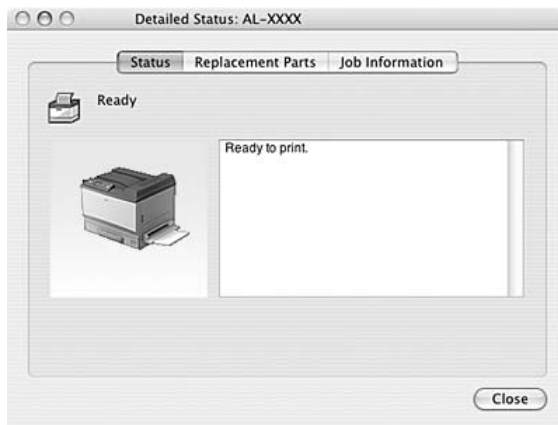

## Replacement Parts Information

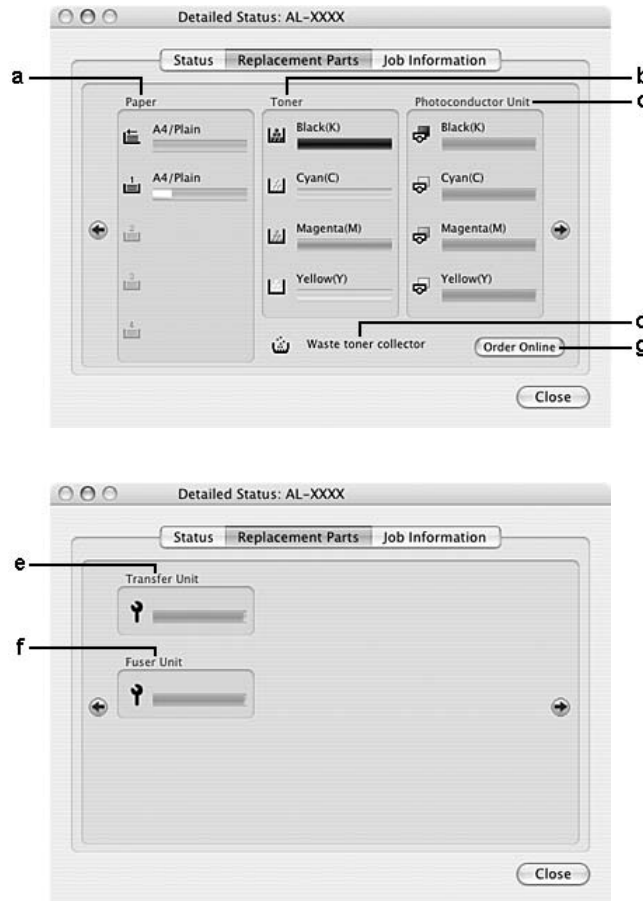

a.	Paper:	Displays the paper size, the paper type and the approximate amount of paper remaining in the paper source.
b.	Toner:	Indicates the remaining service life of the toner cartridges. The toner icon flashes when the toner cartridge has some error or has neared the end of its service life.
c.	Photoconductor Unit:	Indicates the remaining service life of the photoconductor units. The photoconductor unit icon flashes when the photoconductor unit has some error or has neared the end of its service life.
d.	Waste toner collector:	The waste toner collector icon flashes when the waste toner collector has some error or has neared the end of its service life.
e.	Transfer Unit:	Indicates the remaining service life of the transfer unit. The service icon flashes when the transfer unit has some error or has neared the end of its service life.
f.	Fuser Unit:	Indicates the remaining service life of the fuser unit. The service icon flashes when the fuser unit has some error or has neared the end of its service life.

g.	Order Online button:	Clicking this button enables you to order consumables online. See "Order Online" on page 227 for details.
----	----------------------	---

**Note:**

*The remaining service life of the toner cartridge is displayed only if the genuine EPSON toner cartridge is used.*

**Job Information**

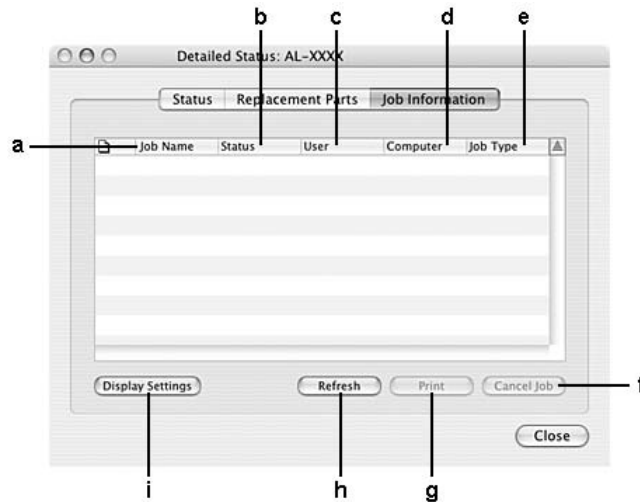

a.	Job Name:	Displays the user's print job names. Other user's print jobs are displayed as -----.	
b.	Status:	Waiting:	Indicates the print job is waiting to be printed.
		Spooling:	Indicates the print job is being spooled on your computer.
		Deleting:	Indicates the print job is being deleted.
		Printing:	Indicates the print job is printed currently.
		Completed:	Indicates the print job has been finished.
		Canceled:	Indicates the print job has been cancelled.
		Held:	Job is on hold.
c.	User:	Displays the user name.	
d.	Computer:	Displays the name of the computer that sent the print job.	

e.	Job Type:	Displays the job type. The jobs are displayed as Stored, Verify, Re-Print, and Confidential respectively. About the Reserve Job function, see "Using the Reserve Job Function" on page 76.
f.	Cancel Job button:	Cancels the selected print job. You can only cancel the jobs you send.
g.	Print button:	Prints the held status job.
h.	Refresh button:	Refreshes the information on this menu.
i.	Display Settings button:	Displays the Display Settings dialog box to select items to be displayed.

## Notice Settings

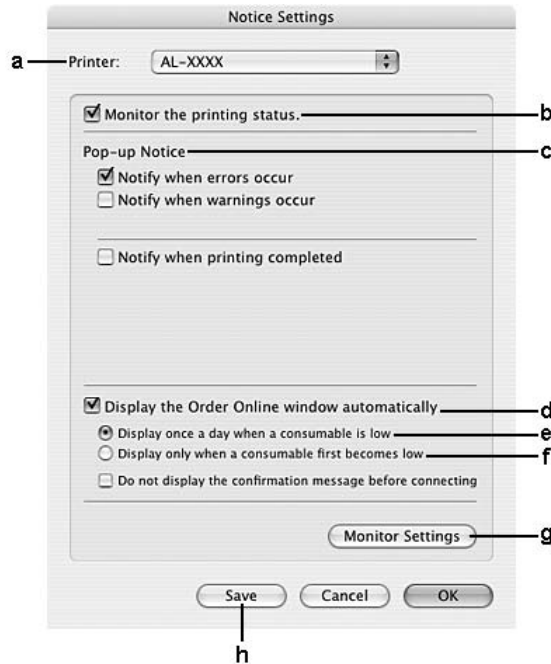

a.	Printer drop-down list:	Select your printer from the drop-down list.
b.	Monitor the printing status check box:	When this check box is selected, EPSON Status Monitor monitors the printer status during a print job is processed.
c.	Pop-up Notice:	Sets the notification to be displayed.

d.	Display the Order Online window automatically check box:	When this check box is selected, the Order Online window appears automatically when a consumable becomes low or reaches end of service life.
e.	Display once a day when a consumable is low check box:	When this radio button is selected, the Order Online window appears automatically once a day when you start printing or display the status by accessing EPSON Status Monitor.
f.	Display only when a replacement part first becomes low check box:	When this radio box is selected, the Order Online window appears automatically only when a replacement part first becomes low.
g.	Monitor Settings button:	Opens the Monitor Settings dialog box to set the monitoring interval.
h.	Save button:	Saves new changes and closes the dialog box.

---

## ***Uninstalling the Printer Software***

### ***For Mac OS X users***

1. Quit all applications on the computer.
2. Insert the EPSON printer software CD-ROM in your Macintosh.
3. Double-click the **Mac OS X** folder.
4. Double-click the **Printer Driver** folder.
5. Double-click your printer's icon.

**Note:**

*If the Authorization dialog box appears, enter the Password or phrase, then click **OK**.*

6. When the software license agreement screen appears, read the statement, click **Continue**, then click **Agree**.
7. Select **Uninstall** from the menu at the upper left, then click **Uninstall**.

8. Follow the on-screen instructions.

## Chapter 10

# About the PostScript Printer Driver

## System Requirements

### Printer hardware requirements

	Recommended
<b>Memory</b>	Standard + 256 MB (for duplex printing of image data at Fine)

**Note:**

Add more memory modules into your printer if the amount of memory currently installed does not meet your printing needs.

### Computer system requirements

<b>OS</b>	Microsoft Windows Vista, Vista x64, XP, XP x64, or 2000 Mac OS X 10.3.9 or later
-----------	---

#### **Windows Vista, Vista x64, XP, XP x64, or 2000**

There are no restrictions for these systems.

#### **Mac OS X**

	Minimum	Recommended
<b>Computer</b>	Power Mac G3, G4, G5, iMac, eMac, PowerBook G3, G4, or iBook	
<b>Hard Disk</b>	—	
<b>Memory</b>	128 MB	

**Note:**

To use binary data, Epson recommends that you use AppleTalk for the printer's network connection. If you use a protocol other than AppleTalk for the network connection, you need to set Binary to On in the PS3 Menu on the control panel. If you use the printer with a local connection, you cannot use binary data.

---

## Using the PostScript Printer Driver with Windows

To print in the PostScript mode, you will have to install the printer driver. See the appropriate sections below for installation instructions according to the interface that you are using to print.

### Installing the PostScript printer driver for the parallel interface

**Caution:**

Never use EPSON Status Monitor and PostScript 3 driver at the same time when the printer is connected via a parallel port. It may damage the system.

**Note:**

- Installing the printer software for Windows Vista, Vista x64, XP, XP x64, or 2000 may require administrator privileges. If you have problems, ask your administrator for more information.
  - Turn off all virus protection programs before installing the printer software.
1. Make sure that the printer is turned off. Insert the printer software CD-ROM into your CD-ROM drive.
  2. For Windows 2000, click **Start**, point to **Settings**, and click **Printers**. Then double-click the **Add Printer** icon.  
For Windows Vista, Vista x64, XP, click **Start**, point to **Printer and Faxes**, and click **Add a printer** in the Printer Tasks menu.
  3. The Add Printer Wizard appears. Then click **Next**.
  4. Select **Local printer**, then click **Next**.

**Note:**

Do not select the **Automatically detect and install my Plug and Play printer** check box.

5. Select **LPT1** as the port the printer is connected to, then click **Next**.



6. Click **Have Disk** and specify the following path for the CD-ROM. If your CD-ROM drive is D:, the path will be D:\ADOBEPS\ENGLISH\PS\_SETUP  
Then click **OK**.

**Note:**

*Change the drive letter as needed for your system.*

7. Select the printer, then click **Next**.
8. Follow the on-screen instructions for the rest of the installation.
9. When installation is done, click **Finish**.

## **Installing the PostScript printer driver for the USB interface**



**Caution:**

*Never use EPSON Status Monitor and PostScript 3 driver at the same time when the printer is connected via a USB port. It may damage the system.*

**Note:**

- Installing the printer software for Windows Vista, Vista x64, XP, XP x64, or 2000 may require administrator privileges. If you have problems, ask your administrator for more information.*
  - Turn off all virus protection programs before installing the printer software.*
1. Make sure that the printer is turned off. Insert the printer software CD-ROM into your CD-ROM drive.
  2. Connect your computer to the printer with a USB cable, then turn on the printer.

**Note for Windows Vista users:**

*Without the Windows driver or the Adobe PS driver, the display shows “Found New Hardware.” In this case, click **Ask me again later**.*

3. For Windows Vista, Vista x64, XP or XP x64, click **Start**, point to **Printer and Faxes**, and click **Add a printer** in the Printer Tasks menu.  
For Windows 2000, click **Start**, point to **Settings**, and click **Printers**. Then double-click the **Add Printer** icon.
4. The Add Printer Wizard appears. Then click **Next**.

5. Select **Local printer**, then click **Next**.

**Note:**

Do not select the **Automatically detect and install my Plug and Play printer** check box.

6. Select **USB** as the port the printer is connected to, then click **Next**.
7. Click **Have Disk** and specify the following path for the CD-ROM. If your CD-ROM drive is D:, the path will be D:\ADOBEPS\ENGLISH\PS\_SETUP. Then click **OK**.

**Note:**

Change the drive letter as needed for your system.

8. Select the printer, then click **Next**.
9. Follow the on-screen instructions for the rest of the installation.
10. When installation is done, click **Finish**.

## **Installing the PostScript printer driver for the network interface**

**Note:**

- Set the network settings before installing the printer driver. Refer to the Network Guide that comes with your printer for details.
  - Turn off all virus protection programs before installing the printer software.
1. Make sure that the printer is turned on. Insert the printer software CD-ROM into your CD-ROM drive.
  2. For Windows Vista, Vista x64, XP, or XP x64, click **Start**, point to **Printer and Faxes**, and click **Add a printer** in the Printer Tasks menu.  
For Windows 2000, click **Start**, point to **Settings**, and click **Printers**. Then double-click the **Add Printer** icon.
  3. The Add Printer Wizard appears. Then click **Next**.
  4. Select **Local printer**, then click **Next**.

**Note:**

Do not select the **Automatically detect and install my Plug and Play printer** check box.

5. Select the **Create a new port check box and select Standard TCP/IP Port** from the drop-down list. Click **Next**.
6. Click **Next**.
7. Specify the IP address and port name, then click **Next**.
8. Click **Finish**.
9. Click **Have Disk** in the Add Printer Wizard and specify the following path for the CD-ROM. If your CD-ROM drive is D:, the path will be D:\ADOBEPS\ENGLISH\PS\_SETUP. Then click **OK**.

**Note:**

*Change the drive letter as needed for your system.*

10. Select the printer and click **Next**.
11. Follow the on-screen instructions for the rest of the installation.
12. When installation is done, click **Finish**.

## **Accessing the PostScript printer driver**

You can change the PostScript printer driver settings in the PostScript printer driver. To access the printer driver, see “Accessing the printer driver” on page 216.

## **Using AppleTalk under Windows 2000**

Use the following settings if your machine is running Windows 2000, and the printer is connected through an network interface using the AppleTalk protocol:

- Select **PS3** as the Network setting in the control panel's **Emulation Menu**.
- On the Device Settings sheet of the printer's Properties dialog box, make sure that **SEND CTRL-D Before Each Job** and **SEND CTRL-D After Each Job** are set to **No**.
- TBCP (Tagged binary communications protocol) cannot be used as the Output Protocol setting.

---

## Using the PostScript Printer Driver with Macintosh

### Installing the PostScript printer driver

**Note:**

Make sure that no applications are running on your Macintosh before installing the printer driver.

#### For Mac OS X users

**Note:**

Make sure that **Print & Fax** (for Mac OS X 10.5) or **Printer Setup Utility** (for Mac OS X 10.4 or below) is not open.

1. Insert the printer software CD-ROM into your CD-ROM drive.
2. Double-click the CD-ROM icon.
3. Double-click **Mac OS X**, then double-click **PS Installer**.
4. The Install EPSON PostScript Software screen appears, click **Continue**, then follow the on-screen instructions.
5. Easy Install is displayed on the screen. Click **Install**.

**Note:**

For Mac OS X 10.4 or below, if the Authenticate window appears, enter the user name and password for an administrator.

6. When installation is done, click **Close**.

### Selecting the printer

After installing the PostScript 3 printer driver, you need to select the printer.

## **In a network environment**

### *For Mac OS X users*

**Note:**

- Although **EPSON FireWire** appears in the interface pop-up list, you cannot use FireWire for printer connection in the PostScript 3 mode.
  - You need to make the settings for your installed options manually when the printer is connected using USB, IP printing, or Bonjour (Rendezvous). When the printer is connected using AppleTalk, the printer software automatically makes the settings.
  - Make sure to specify ASCII as the data format in the application.
1. For Mac OS X 10.5 users, open the System Preferences, and then double-click the Print & Fax icon.  
For Mac OS X 10.4 or below users, open the **Applications** folder, open the **Utilities** folder, and then double-click **Printer Setup Utility**.  
The Printer List window appears.
  2. Click **Add** in the Printer List window.
  3. Select the protocol or the interface that you are using from the pop-up list.

**Note for AppleTalk users:**

Make sure to select **AppleTalk**. Do not select **EPSON AppleTalk**, because it cannot be used with the PostScript 3 printer driver.

**Note for IP Printing users:**

- Make sure to select **IP Printing**. Do not select **EPSON TCP/IP**, because it cannot be used with the PostScript 3 printer driver.
- After selecting **IP Printing**, enter the IP address for the printer, then make sure to select the **Use default queue on server** check box.

**Note for USB users:**

Make sure to select **USB**. Do not select **EPSON USB**, because it cannot be used with the PostScript 3 printer driver.

4. Follow the instructions as appropriate below to select your printer.

#### **AppleTalk**

Select your printer from the Name List, then select **Auto Select** from the Printer Model List.

#### **IP Printing**

Select **Epson** from the Name List, then select your printer from the Printer Model List.

#### **USB**

Select your printer from the Name List, then select your printer from the Printer Model List.

#### **Note for Mac OS X 10.4 or below users:**

*If ESC/Page driver is not installed, your printer model is automatically selected in the Printer Model List when you select your printer from the Name List while the printer is on.*

#### **Bonjour (Rendezvous)**

Select your printer, the printer name is followed by **(PostScript)**, from the Name List. Your printer model is automatically selected in the Printer Model List.

#### **Note for Bonjour (Rendezvous) users:**

*If your printer model is not automatically selected in the Printer Model list, you need to reinstall the PostScript printer driver. See “Installing the PostScript printer driver” on page 244.*

5. Click **Add**.

#### **Note for IP Printing users, USB or Bonjour (Rendezvous) users:**

*Select your printer from the Printer list, then select **Show Info** from the Printers menu. The Printer Info dialog box appears. Select **Installable Options** from the pop-up list, then make the necessary settings.*

6. Confirm that your printer's name is added to the Printer List. Then quit **Print & Fax** (for Mac OS X 10.5) or **Printer Setup Utility** (for Mac OS X 10.4 or below).

## **Accessing the PostScript printer driver**

You can change the PostScript printer driver settings in the PostScript printer driver. To access the printer driver, see “Accessing the printer driver” on page 216.

## **Changing the printer setup settings**

You can change or update the printer setup settings according to the options installed in your printer.

RI Tech:        On

*For Mac OS X users*

1. Access the printer driver. The Printer List window appears.
2. Select the printer from the list.
3. Select **Show Info** from the Printers menu. The Printer Info dialog box appears.
4. Make necessary changes to the settings, then close the dialog box.
5. Quit **Print & Fax** (for Mac OS X 10.5) or **Printer Setup Utility** (for Mac OS X 10.4 or below).

## Chapter 11

### About the PCL5/PCL6 Printer Driver

#### System Requirements

##### Printer hardware requirements

Minimum memory	Recommended memory
128 MB* (for a simple print job at 600 dpi)	256 MB* or more

\* Printing may not be possible with this amount of memory, depending on the specifics of the job being printed.

**Note:**

Add more memory modules into your printer if the amount of memory currently installed does not meet your printing needs.

##### Computer system requirements

OS	Microsoft Windows Vista, Vista x64, XP, XP x64, Server 2003, Server 2003 x64, or have installed the 2000 Service Pack 3 or later.
----	---

##### For Windows Vista

	Minimum	Recommended
<b>Computer</b>	IBM PC series or IBM compatible with PentiumIII 800MHz or higher CPU	IBM PC series or IBM compatible with PentiumIII 1GHz or higher CPU
<b>Hard Disk</b>	10-25 MB free (for driver installation)	
<b>Memory</b>	512MB	512 MB
<b>Display</b>	Super VGA supporting	DirectX 9 with 32MB graphics memory or more



**For Windows Vista x64**

	<b>Minimum</b>	<b>Recommended</b>
<b>Computer</b>	IBM PC series or IBM compatible with Intel EM64T or AMD/64 CPU	IBM PC series or IBM compatible with Intel EM64T or AMD/64 CPU
<b>Hard Disk</b>	10-25 MB free (for driver installation)	
<b>Memory</b>	512MB	512 MB
<b>Display</b>	Super VGA supporting	DirectX 9 with 32MB graphics memory or more

**For Windows XP or 2000**

	<b>Minimum</b>	<b>Recommended</b>
<b>Computer</b>	IBM PC series or IBM compatible with Pentium or higher CPU	IBM PC series or IBM compatible with Pentium II or higher CPU
<b>Hard Disk</b>	10-25 MB free (for driver installation)	
<b>Memory</b>	128 MB (256 MB for Server 2003)	256 MB
<b>Display</b>	Super VGA supporting 640 × 480	Super VGA supporting 800 × 600 or more

**For Windows XP x64 or 2003 Server x64**

	<b>Minimum</b>	<b>Recommended</b>
<b>Computer</b>	IBM PC series or IBM compatible with Intel EM64T or AMD/64 CPU	
<b>Hard Disk</b>	10-25 MB free (for driver installation)	
<b>Memory</b>	256 MB	512 MB
<b>Display</b>	Super VGA supporting 640 × 480	Super VGA supporting 800 × 600 or more

**Using the PCL5/PCL6 Printer Driver**

To print in the PCL mode, you will have to install the printer driver. Consult the customer support in your region regarding how to get the printer driver.

**Note:**

The PCL5/PCL6 printer driver and EPSON Status Monitor cannot be used at the same time.

## Installing the PCL5/PCL6 printer driver

**Note:**

- ❑ *Installing the printer software for Windows XP or 2000 may require administrator privileges. If you have problems, ask your administrator for more information.*
  - ❑ *Turn off all virus protection programs before installing the printer software.*
  - ❑ *The examples in this section are from the Windows XP operating system. They may vary in appearance from what actually appears on your screen; however, the instructions are the same.*
1. Make sure that the printer is turned on.
  2. Double-click **SETUP.EXE**. The End User License Agreement dialog box appears.
  3. Select the name of your printer, then click **OK**.
  4. Read the license agreement, then click **Accept**.

The EPSON Printer Utilities Setup dialog box appears, and the program searches for the printer and automatically configures the port.

**Note:**

*If you are using a parallel interface cable, click **Cancel**, and then click **OK**. The parallel port is configured automatically.*

5. When the installation is complete, click **OK**.

After the installation is done, click **Printer Properties** to make the appropriate settings.

**Note:**

*If you want to change the settings, you can access the PCL5/PCL6 printer driver by clicking **Document Default**.*

## Accessing the PCL5/PCL6 printer driver

You can change the PCL5/PCL6 printer settings in the PCL5/PCL6 printer driver. To access the printer driver, see “Accessing the printer driver” on page 216.

### ***Updating the printer driver***

When you install optional products, you have to update the printer driver manually. See the following instructions.

1. Click the **Printer** tab of the Properties dialog box.
2. Select the option that you installed.

## Appendix A

### Technical Specifications

#### Paper

Since the quality of any particular brand or type of paper may be changed by the manufacturer at any time, Epson cannot guarantee the quality of any type of paper. Always test samples of paper stock before purchasing large quantities or printing large jobs.

#### Available paper types

Paper type	Description
Plain paper	Weight: 64 to 90 g/m <sup>2</sup> (Recycled paper is acceptable. *)
Envelopes	No paste and no tape. No plastic window. (unless specifically designed for laser printers.)
Labels	The backing sheet should be covered completely, with no gaps between labels.
EPSON Color Laser Transparencies	Transparencies for color laser printers or copiers.
Thick paper	Weight: 91 to 150 g/m <sup>2</sup>
Extra thick paper	Weight: 151 to 209 g/m <sup>2</sup>
Super thick paper	Weight: 210 to 256 g/m <sup>2</sup>
EPSON Color Laser Coated Paper	Weight: 103 g/m <sup>2</sup>
Colored paper	Non coated
Paper with letterhead	Paper and ink of letterheads must be compatible with laser printers.

\* Use recycled paper only under normal temperature and humidity conditions. Poor quality paper may reduce print quality, or cause paper jams and other problems.

#### Paper that should not be used

You cannot use the following paper in this printer. It may cause printer damage, paper jams, and poor print quality:

- Media meant for other color laser printers, black-and-white laser printers, color copiers, black-and-white copiers, or ink jet printers
- Previously printed paper by any other color laser printers, black-and-white laser printers, color copiers, black-and-white copiers, ink jet printers, or thermal transfer printers
- Carbon paper, carbonless paper, thermal-sensitive paper, pressure-sensitive paper, acid paper, or paper that uses high-temperature-sensitive ink (around 200 °C)
- Labels that peel easily or labels that do not cover the backing sheet completely
- Special surface-coated paper or special surface-colored paper
- Paper that has binder holes or is perforated
- Paper that has glue, staples, paper clips, or tape on it
- Paper that attracts static electricity
- Moist or damp paper
- Paper of uneven thickness
- Overly thick or thin paper
- Paper that is too smooth or too rough
- Paper that is different on the front and back
- Paper that is folded, curled, wavy, or torn
- Paper of irregular shape, or paper that does not have right angle corners

## ***Printable area***

The assured printable area is an area 5 mm from all sides.

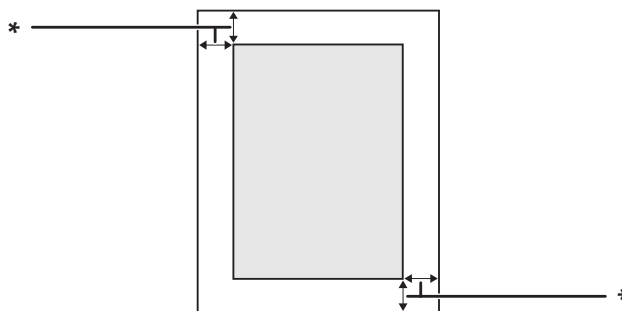

\* 5 mm

**Note:**

- ❑ *The printable area may be smaller depending on the application.*
- ❑ *When printing on A3F size paper, the minimum margin on right and left sides is 7 mm.*

## Printer

### General

Printing method:	Laser beam scanning and dry electrophotographic process	
Resolution:	300 × 300 dpi, 600 × 600 dpi	
Continuous printing speed*:	Up to 26 pages per minute on A4 size paper	
Paper feed:	Automatic or manual feed	
Paper feed alignment:	Center alignment for all sizes	
Input paper supply:		
MP tray:	plain paper	Up to a 12.5 mm thick stack, or up to 100 sheets (64 to 90 g/m <sup>2</sup> )
	envelopes	Up to a 12.5 mm thick stack
	transparencies	Up to a 12.5 mm thick stack
	labels	Up to a 12.5 mm thick stack
	thick paper	Up to a 12.5 mm thick stack
	extra thick paper	Up to a 12.5 mm thick stack
	super thick paper	Up to a 12.5 mm thick stack
Standard lower paper cassette:	plain paper	Up to a 29 mm thick stack, or up to 250 sheets (64 to 90 g/m <sup>2</sup> )
Optional paper cassette unit:	plain paper	Up to a 57.5 mm thick stack, or up to 500 sheets (64 to 90 g/m <sup>2</sup> )
Paper output capacity:	Up to 500 sheets of plain paper (64 to 90 g/m <sup>2</sup> )	

Printer language:	ECP/Page
	ESC/P 2 24-pin printer emulation (ESC/P 2 mode)
	ESC/P 9-pin printer emulation (FX mode)
	IBM Proprinter emulation (I239X mode)
	Adobe PostScript3 (PS3 mode)
	PCL6/PCL5 emulation (PCL mode)
Resident fonts:	84 scalable fonts, and 7 bitmap fonts for ESC/Page 95 scalable fonts, and 5 bitmap for PCL5 80 scalable fonts, and 1 bitmap for PCL6 136 scalable fonts for PostScript3
RAM:	256 MB, expandable up to 768 MB

\* Printing speed varies by paper type or other conditions.

## Environmental

Temperature:	In use:	10 to 35°C (50 to 95°F)
	Not in use:	0 to 35°C (32 to 95°F)
Humidity:	In use:	15 to 85% RH
	Not in use:	10 to 85% RH
Altitude:	2,000 meters (6,562 feet) maximum	

## Mechanical

Dimensions	Height:	477 mm (18.8 in.)
	Width:	823 mm (32.4 in.)
	Depth:	608 mm (23.9 in.)
Weight	Approx. 49.5 kg (about 109.1 lb) (Excluding consumables and options)	

## Electrical

			120 V Model L551A	220-240 V Model L551A
Rated voltage			110 V-120 V	220 V-240 V
Rated frequency			50 Hz-60 Hz	50 Hz-60 Hz
Rated current			12.0 A	8.0 A
Power consumption	During printing	Average	581 W (color mode)	576 W (color mode)
			543 W (black-and-white mode)	522 W (black-and-white mode)
		MAX	1340 W	1390 W
	During ready mode		139 W	146 W
	During sleep mode*		11 W or below	11 W or below

\* Values represent power consumption while all operations are completely suspended. Power consumption varies depending on operating conditions, and whether a type-B interface card is installed or a USB memory is inserted.

## Standard and approvals

European model:

Low Voltage Directive 2006/95/EC	EN 60950-1
EMC Directive 2004/108/EC	EN 55022 Class B
	EN 55024
	EN 61000-3-2
	EN 61000-3-3

---

## Interfaces

### Parallel Interface

Use the IEEE 1284-I compliant parallel interface connector.

ECP mode/Nibble mode



## USB interface

USB 2.0 High Speed mode

### Note:

- ❑ Only computers equipped with a USB connector and running Windows Vista, Vista x64, XP, XP x64, 2000, Server 2003, or Server 2003 x64, support the USB interface.
- ❑ Your computer must support USB 2.0 in order to use USB 2.0 as the interface to connect your computer to the printer.
- ❑ Since USB 2.0 is fully compatible with USB 1.1, USB 1.1 can be used as an interface.
- ❑ USB 2.0 can be used with Windows Vista, Vista x64, XP, XP x64, 2000, Server 2003, and Server 2003 x64, operating systems.

## Ethernet interface

You can use an IEEE 802.3 100BASE-TX/10 BASE-T straight-through shielded, twisted-pair interface cable with an RJ45 connector.

---

## Options and Consumable Products

### Optional paper cassette unit

Product code/Model:	C12C802502/L551AC1*
Paper size:	A3, A4, B4, B5, Letter (LT), Legal (LGL), Ledger (B), F4
Paper weight:	64 to 90 g/m <sup>2</sup> (17 to 24 lb)
Paper feed:	One paper cassette mounted Automatic feed delivery system Cassette capacity up to 500 sheets
Paper types:	Plain paper
Power supply:	DC 24V / 0.5 A and DC 5 V / 0.2 A supplied by the printer
Dimensions and weight:	
Height:	168 mm (6.6 in.)

Width:	577 mm (22.7 in.)
Depth:	548 mm (21.6 in.)
Weight:	14.8 kg (32.6 lb) including cassette

\* This product conforms to CE marking requirements in accordance with EC Directive 2004/108/EC.

## Duplex Unit

Product code/Model:	C12C802512/L551ADU*
Paper size:	A3, A4, A5, B4, B5, Letter (LT), Legal (LGL), Government Letter (GLT), Government Legal (GLG), Ledger (B), Executive (EXE), F4, A3F
Paper weight:	64 to 256 g/m <sup>2</sup> (17 to 68 lb)
Paper feed:	Automatic feed delivery system
Paper types:	Plain paper, Thick paper, Extra thick paper, Super thick paper, EPSON Color Laser Coated Paper
Power supply:	DC 24V / 1.0 A and DC 5 V / 0.1 A supplied by the printer
Dimensions and weight:	
Height:	336 mm (13.2 in.)
Width:	100 mm (3.9 in.)
Depth:	440 mm (17.3 in.)
Weight:	2.8 kg (6.2 lb) including cassette

\* This product conforms to CE marking requirements in accordance with EC Directive 2004/108/EC.

## Printer Stand

Product code:	C12C847092
Dimensions and weight:	
Height:	96 mm (3.8 in.)
Width:	535 mm (21.1 in.)
Depth:	508 mm (20.0 in.)

Weight:	9.5 kg (21 lb) including bundled items
---------	--

## Memory modules

Make sure that DIMM you purchase is compatible with EPSON products. For details, contact the store where you purchased this printer or the EPSON sales company.

Memory size:	128, 256, or 512 MB
--------------	---------------------

## CompactFlash memory

Contact the EPSON sales company for detail information.

## Toner Cartridge

Product code/Model:	Toner Cartridge (Yellow)	0474/0474*
	Toner Cartridge (Magenta)	0475/0475*
	Toner Cartridge (Cyan)	0476/0476*
	Toner Cartridge (Black)	0477/0477*
Storage temperature:	0 to 35°C (32 to 95°F)	
Storage humidity:	30 to 85% RH	

\* This product conforms to CE marking requirements in accordance with EMC Directive 2004/108/EC.

## Photoconductor Unit

Product code/Model:	Photoconductor Unit (Yellow)	1175/1175*
	Photoconductor Unit (Magenta)	1176/1176*
	Photoconductor Unit (Cyan)	1177/1177*
	Photoconductor Unit (Black)	1178/1178*

Storage temperature:	0 to 35°C (32 to 95°F)
Storage humidity:	30 to 85% RH

\* This product conforms to CE marking requirements in accordance with EMC Directive 2004/108/EC.

## ***Waste Toner Collector***

Product code:	0478
Storage temperature:	0 to 35°C (32 to 95°F)
Storage humidity:	30 to 85% RH

## Appendix B

# Customer Support

---

## Contacting Customer Support

---

### Before Contacting Epson

If your Epson product is not operating properly and you cannot solve the problem using the troubleshooting information in your product documentation, contact customer support services for assistance. If customer support for your area is not listed below, contact the dealer where you purchased your product.

Customer support will be able to help you much more quickly if you give them the following information:

- Product serial number  
(The serial number label is usually on the back of the product.)
- Product model
- Product software version  
(Click **About**, **Version Info**, or similar button in the product software.)
- Brand and model of your computer
- Your computer operating system name and version
- Names and versions of the software applications you normally use with your product

### Help for Users in Australia

Epson Australia wishes to provide you with a high level of customer service. In addition to your product documentation, we provide the following sources for obtaining information:

#### Your Dealer

Don't forget that your dealer can often help identify and resolve problems. The dealer should always be the first call for advice on problems; they can often solve problems quickly and easily as well as give advice on the next step to take.

**Internet URL <http://www.epson.com.au>**

Access the Epson Australia World Wide Web pages. Worth taking your modem here for the occasional surf! The site provides a download area for drivers, Epson contact points, new product information and technical support (e-mail).

**Epson Helpdesk**

Epson Helpdesk is provided as a final backup to make sure our clients have access to advice. Operators on the Helpdesk can aid you in installing, configuring and operating your Epson product. Our Pre-sales Helpdesk staff can provide literature on new Epson products and advise where the nearest dealer or service agent is located. Many types of queries are answered here.

The Helpdesk numbers are:

Phone: 1300 361 054

Fax: (02) 8899 3789

We encourage you to have all the relevant information on hand when you ring. The more information you prepare, the faster we can help solve the problem. This information includes your Epson product documentation, type of computer, operating system, application programs, and any information you feel is required.

**Help for Users in Singapore**

Sources of information, support, and services available from Epson Singapore are:

**World Wide Web (<http://www.epson.com.sg>)**

Information on product specifications, drivers for download, Frequently Asked Questions (FAQ), Sales Enquiries, and Technical Support via e-mail are available.

**Epson HelpDesk (Phone: (65) 6586 3111)**

Our HelpDesk team can help you with the following over the phone:

- Sales enquiries and product information
- Product usage questions or problem
- Enquiries on repair service and warranty

## ***Help for Users in Thailand***

Contact for information, support, and services are:

### ***World Wide Web (<http://www.epson.co.th>)***

Information on product specifications, drivers for download, Frequently Asked Questions (FAQ), and e-mail are available.

### ***Epson Hotline (Phone: (66)2-670-0333)***

Our Hotline team can help you with the following over the phone:

- Sales enquiries and product information
- Product usage questions or problem
- Enquiries on repair service and warranty

## ***Help for Users in Vietnam***

Contacts for information, support, and services are:

Epson Hotline (Phone): 84-8-823-9239

Service Center: 80 Truong Dinh Street, District 1, Hochiminh City Vietnam

## ***Help for Users in Indonesia***

Contacts for information, support, and services are:

### ***World Wide Web (<http://www.epson.co.id>)***

- Information on product specifications, drivers for download
- Frequently Asked Questions (FAQ), Sales Enquiries, questions through e-mail

### ***Epson Hotline***

- Sales enquiries and product information

Technical support

Phone (62) 21-572 4350

Fax (62) 21-572 4357

**Epson Service Center**

Jakarta Mangga Dua Mall 3rd floor No 3A/B  
Jl. Arteri Mangga Dua,  
Jakarta  
Phone/Fax: (62) 21-62301104

Bandung Lippo Center 8th floor  
Jl. Gatot Subroto No.2  
Bandung  
Phone/Fax: (62) 22-7303766

Surabaya Hitech Mall It IIB No. 12  
Jl. Kusuma Bangsa 116 – 118  
Surabaya  
Phone: (62) 31-5355035  
Fax: (62)31-5477837

Yogyakarta Hotel Natour Garuda  
Jl. Malioboro No. 60  
Yogyakarta  
Phone: (62) 274-565478

Medan Wisma HSBC 4th floor  
Jl. Diponegoro No. 11  
Medan  
Phone/Fax: (62) 61-4516173

Makassar MTC Karebosi Lt. III Kav. P7-8  
Jl. Ahmad Yani No.49  
Makassar  
Phone: (62)411-350147/411-350148



## ***Help for Users in Hong Kong***

To obtain technical support as well as other after-sales services, users are welcome to contact Epson Hong Kong Limited.

### ***Internet Home Page***

Epson Hong Kong has established a local home page in both Chinese and English on the Internet to provide users with the following information:

- Product information
- Answers to Frequently Asked Questions (FAQs)
- Latest versions of Epson product drivers

Users can access our World Wide Web home page at:

<http://www.epson.com.hk>

### ***Technical Support Hotline***

You can also contact our technical staff at the following telephone and fax numbers:

Phone: (852) 2827-8911

Fax: (852) 2827-4383

## ***Help for Users in Malaysia***

Contacts for information, support, and services are:

### ***World Wide Web (<http://www.epson.com.my>)***

- Information on product specifications, drivers for download
- Frequently Asked Questions (FAQ), Sales Enquiries, questions through e-mail

### ***Epson Trading (M) Sdn. Bhd.***

Head Office.

Phone: 603-56288288

Fax: 603-56288388/399

### *Epson Helpdesk*

- Sales enquiries and product information (Infoline)

Phone: 603-56288222

- Enquiries on repair services & warranty, product usage and technical support (Techline)

Phone: 603-56288333

## ***Help for Users in India***

Contacts for information, support, and services are:

### ***World Wide Web (<http://www.epson.co.in>)***

Information on product specifications, drivers for download, and products enquiry are available.

### ***Epson India Head Office - Bangalore***

Phone: 080-30515000

Fax: 30515005

### ***Epson India Regional Offices:***

<b>Location</b>	<b>Telephone number</b>	<b>Fax number</b>
Mumbai	022-28261515 /16/17	022-28257287
Delhi	011-30615000	011-30615005
Chennai	044-30277500	044-30277575
Kolkata	033-22831589 / 90	033-22831591
Hyderabad	040-66331738/ 39	040-66328633

Location	Telephone number	Fax number
Cochin	0484-2357950	0484-2357950
Coimbatore	0422-2380002	NA
Pune	020-30286000 /30286001/30286002	020-30286000
Ahmedabad	079-26407176 / 77	079-26407347

### **Helpline**

For Service, Product info or to order a cartridge - 18004250011 (9AM - 9PM) - This is a Toll-free number.

For Service (CDMA & Mobile Users) - 3900 1600 (9AM - 6PM) Prefix local STD code

### **Help for Users in the Philippines**

To obtain technical support as well as other after sales services, users are welcome to contact the Epson Philippines Corporation at the telephone and fax numbers and e-mail address below:

Phone: (63) 2-813-6567  
 Fax: (63) 2-813-6545  
 E-mail: [epchelpdesk@epc.epson.com.ph](mailto:epchelpdesk@epc.epson.com.ph)

### **World Wide Web** (<http://www.epson.com.ph>)

Information on product specifications, drivers for download, Frequently Asked Questions (FAQ), and E-mail Enquiries are available.

### **Epson Helpdesk (Phone: (63) 2-813-6567)**

Our Hotline team can help you with the following over the phone:

- Sales enquiries and product information
- Product usage questions or problems
- Enquiries on repair service and warranty

## Index

- A**
- Anti-copy (copy protection) function
    - how to use (Windows).....72
  - AUX menu.....95
  - Available paper.....252
- B**
- Bookmark menu.....106
- C**
- Canceling printing.....122, 210
  - Clock menu.....92
  - CompactFlash memory
    - how to install.....156
    - how to remove.....158
    - specifications.....259
  - Confidential Job menu.....92, 120
  - Consumable products
    - Replacing.....160
  - Consumables
    - specification (photoconductor unit).....259
    - specification (toner cartridge).....259
    - specification (waste toner collector).....260
  - Contacting Epson.....261
  - Control panel.....122
    - overview.....25
  - Control panel menus
    - about.....79
    - AUX.....95
    - bookmark.....106
    - clock.....92
    - confidential job.....92, 120
    - emulation.....85
    - ESCP2.....98
    - FX.....100
    - how to access.....79
    - I239X.....102
    - information.....81
    - network.....95
    - panel settings.....79
    - parallel.....92
    - password config.....105
    - PCL.....95
    - printing.....85
    - PS3.....97
    - quick print job.....92, 120
    - reserve job data.....119
    - reset.....91
    - setup.....87
    - system information.....84
    - tray.....84
    - USB.....94
- D**
- Duplex printing.....53
  - Duplex Unit
    - how to install.....137
    - how to remove.....144
    - specifications.....258
- E**
- Emulation menu.....85
  - EPSON Status Monitor
    - Accessing EPSON Status Monitor (Macintosh).....231
    - Accessing EPSON Status Monitor (Windows).....220
    - Installing EPSON Status Monitor (Windows).....218
    - Job Information (Macintosh).....235
    - Job Information (Windows).....223
    - Notice Settings (Macintosh).....236
    - Notice Settings (Windows).....225
    - Order Online.....227
    - Replacement Parts information (Macintosh).....234
    - Replacement Parts Information (Windows).....222
    - Status (Macintosh).....233
    - Status (Windows).....221
  - ESCP2 menu.....98
  - Ethernet.....257

<b>F</b>	
FX menu.....	100
<b>G</b>	
Guides	
Font Guide.....	21
Network Guide.....	21
Online Help.....	21
Paper Jam Guide.....	21
Setup Guide.....	21
User's Guide.....	21
<b>H</b>	
Headers and footers.....	65
Help	
Epson.....	261
Hidden Watermark (copy protection) function.....	72
How to register menus as bookmarks.....	80
<b>I</b>	
I239X menu.....	102
Information menu.....	81
Installing options	
installing a CompactFlash memory.....	156
installing a memory module.....	150
installing an interface card.....	154
installing the duplex unit.....	137
installing the optional paper cassette unit.....	128
installing the optional printer stand.....	125
removing a CompactFlash memory.....	158
removing a memory module.....	153
removing an interface card.....	156
removing the duplex unit.....	144
removing the optional paper cassette unit.....	136
Installing the postScript printer driver (Macintosh)	
.....	244
Installing the PostScript printer driver for the network interface (Windows).....	242
Installing the PostScript printer driver for the parallel interface (Windows).....	240
Installing the PostScript printer driver for the USB interface (Windows).....	241
Interface cards	
how to install.....	154
how to remove.....	156
Interfaces	
ethernet.....	257
Parallel.....	256
USB.....	257
<b>M</b>	
Maintenance	
printer.....	174
Printer (exposure window).....	176
Printer (pickup roller).....	174
Memory module	
how to install.....	150
how to remove.....	153
specifications.....	259
Monochrome Model Compatibility mode.....	53
MP tray	
Specifications.....	28
Supported paper.....	28
<b>N</b>	
Network menu.....	95
<b>O</b>	
Optional paper cassette unit	
how to install.....	128
how to remove.....	136
specifications.....	257
Options	
specifications (CompactFlash).....	259
specifications (duplex unit).....	258
specifications (hard disk drive).....	259
specifications (memory module).....	259
specifications (optional paper cassette unit).....	257
specifications (Printer Stand).....	258
Overlay	
how to create (Windows).....	68
how to print (Windows).....	69

how to use (Windows).....	67
<b>P</b>	
Paper	
available paper.....	252
loading the MP tray.....	28
loading the optional paper cassette.....	35
loading the standard lower paper cassette.....	30
printable area.....	253
Special media.....	40
unavailable paper.....	252
Paper Jam A (Cover A).....	184
Paper Jam B H (Cover B or H).....	185
Paper Jam D (Duplex Unit cover).....	189
Paper Jam E* (Cover E*).....	193
Paper Jam G (Paper path G).....	192
Paper jams	
how to clear.....	183
Paper source	
MP tray.....	28
optional paper cassette.....	35
standard lower paper cassette.....	30
Parallel Interface.....	256
Parallel menu.....	92
Password config menu.....	105
PCL menu.....	95
PCL printer driver	
about the PCL Mode.....	248
hardware requirements.....	248
system requirements.....	248
Photoconductor unit	
Specifications.....	259
PostScript printer driver	
Accessing the PostScript printer driver (Macintosh)	
.....	246
Accessing the PostScript printer driver (Windows)	
.....	243
hardware requirements.....	239
Installing the PostScript printer driver for Mac OS X	
users.....	244
Selecting a printer in a network environment for Mac	
OS X users.....	245
PostScript printer driver settings	
Using AppleTalk under Windows 2000.....	243
Precautions	
Replacing consumable products.....	160
Printer	
cleaning.....	174
cleaning (exposure window).....	176
cleaning (pickup roller).....	174
consumable products.....	27
electrical.....	256
environmental.....	255
general.....	254
mechanical.....	255
optional products.....	26
parts (front view).....	22
parts (inside).....	24
parts (rear view).....	23
standard and approvals.....	256
transporting.....	179
transporting (long distance).....	180
transporting (short distance).....	181
Printer driver	
Accessing the printer driver (Macintosh).....	230
Accessing the printer driver (Windows).....	216
Uninstalling the Printer Software (Macintosh).....	237
Uninstalling the Printer software (Windows).....	227
Printer driver settings	
Creating an overlay (Windows).....	68
Delete the form overlay data on the storage.....	71
Duplex printing.....	53
Making a new watermark.....	62
Making Extended settings (Macintosh).....	231
Making Extended settings (Windows).....	217
Making Optional settings (Windows).....	217
Printing the copy-protected document.....	72
Printing with an overlay.....	69
Printing with storage form overlay.....	71
print layout.....	56
Register the storage form overlay data on the storage	
.....	70
Re-Print Job.....	77
Reserve Job.....	76
Using an overlay.....	67
Using a watermark.....	59
Using headers and footers.....	65
Using storage form overlay.....	70
Printer software (Macintosh)	

about.....	230	Specifications.....	259
Printer software (Windows)		Toner Save mode.....	52
About.....	216	Transporting the printer (long distance).....	180
Printer stand		Transporting the printer (short distance).....	181
how to install.....	125	Tray menu.....	84
specifications.....	258	Troubleshooting.....	106, 121, 183, 195, 210
Printing menu.....	85	color printing problems.....	199
Print layout		memory problems.....	205
Modifying the print layout.....	56	network connection problems.....	209
Problems, solving		operational problems.....	195
contacting Epson.....	261	options.....	206
PS3 menu.....	97	paper handling problems.....	206
		PCL6 mode.....	214
<b>Q</b>		PostScript 3 mode.....	210
Quick Print Job menu.....	92, 120	printout problems.....	197
		print quality problems.....	200
<b>R</b>		USB problems.....	208
Relocating the printer.....	179		
Replacement Messages.....	160	<b>U</b>	
Reserve job data.....	119	Unavailable paper.....	252
Reset menu.....	91	USB.....	257
		USB menu.....	94
<b>S</b>			
Service.....	261	<b>W</b>	
Setup menu.....	87	Waste toner collector	
Special media		Specifications.....	260
Printing on.....	40	Watermark	
Status and error messages.....	106	how to make.....	62
Status sheet		how to use.....	59
how to print.....	121, 195		
Storage form overlay			
how to delete (Windows).....	71		
how to print (Windows).....	71		
how to register (Windows).....	70		
how to use (Windows).....	70		
System information menu.....	84		
<b>T</b>			
Toner			
Toner Save mode.....	52		
Toner cartridge			