

EPSON AcuLaser C3800 Series

EN	Setup Guide
DE	Installationshandbuch
FR	Guide d'installation
IT	Guida de installazione
ES	Guía de instalación
CA	Manual d'instal·lació
PT	Manual de instalação
NL	Installatiehandleiding
DA	Installationsvejledning
FI	Asennusopas
NO	Installeringshåndbok
SV	Installationshandbok
CS	Instalační příručka
HU	Üzembe helyezési útmutató
PL	Podręcznik konfiguracji i instalacji
SK	Inštaláčn� príručka
BG	Ръководство за инсталация
RO	Ghid de instalare
EE	Seadistusjuhend
LV	Uzst�d�šanas instrukcija
LT	Parengties vadovas

EL	Οδηγός εγκατάστασης
TR	Kurulum kılavuzu
SL	Priročnik za namestitev
HR	Vodič za postavu
MK	Упатство за поставување
SR	Uputstvo za postavljanje
RU	Руководство по установке
AR	دليل الإعداد
FA	راهنمای تنظیم
CN	首先阅读
TW	安裝說明
KR	설치안내시트

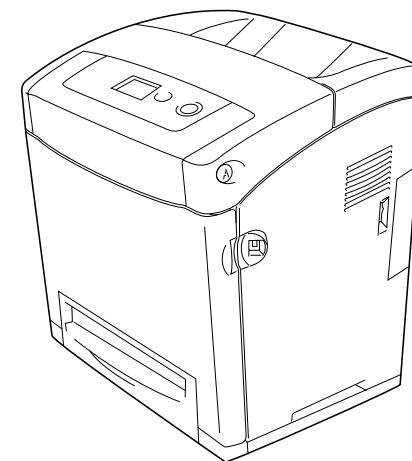

EN	For detailed information and safety recommendations, refer to the User's Guide (installed with the software).
DE	Ausführliche Informationen und Sicherheitsempfehlungen finden Sie im Benutzerhandbuch, das mit der Software installiert wurde.
FR	Pour plus d'informations et des recommandations concernant la sécurité, reportez-vous au Guide de l'utilisateur (installé avec le logiciel).
IT	Per informazioni dettagliate e suggerimenti sulla sicurezza consultare la Guida per l'utente installata con il software.
ES	Para obtener información detallada y recomendaciones sobre seguridad consulte la Guía de usuario (instalada con el software).
CA	Per obtenir informació detallada consulti el Manual d'usuari (instal·lada amb el software).
PT	Para mais informações e recomendações sobre segurança, consulte o Manual do Utilizador (instalado com o software).
NL	Raadpleeg de gebruikershandleiding (geïnstalleerd met de software) voor meer informatie en veiligheidsvoorschriften\
DA	Der findes yderligere oplysninger og anbefalinger om sikkerhed i brugervejledningen (installeret sammen med softwaren).
FI	Lisätietoja ja turvaohjeita on Käyttöoppaassa (asennetaan ohjelmiston kanssa).
NO	Hvis du vil ha mer detaljert informasjon og sikkerhetsanbefalinger, kan du se i brukerhåndboken (som installeret med programvaren).
SV	Detaljerad information och säkerhetsföreskrifter finns i Användarhandboken (installeras tillsammans med programmet).
CS	Podrobné informace a bezpečnostní doporučení najdete v Uživatelské příručce (instaluje se společně se softwarem).
HU	Részletes információk és a biztonsággal kapcsolatos tudnivalók a szoftverrel együtt telepített használati útmutatóban található.
PL	Szczegółowe informacje oraz zalecenia dotyczące bezpieczeństwa zawiera Podręcznik użytkownika (instalowany razem z oprogramowaniem)
SK	Podrobné informácie a bezpečnostné odporúčanie nájdete v Uživatelskej príručke (inštaluje sa spolu so softvérom).
BG	Подробна информация и препоръки за безопасност ще намерите в Ръководството за потребителя (инсталирано със софтуера).

RO	Pentru informații detaliate și recomandări cu privire la siguranță, consultați User's Guide (Ghidul utilizatorului instalat cu software-ul).
EE	Lähemat teavet ja ohutusalseid soovitusi vt (koos tarkvaraga installeeritud) kasutusjuhendist User's Guide.
LV	Sīkāku informāciju un ieteikumus par drošību skat. Lietotāja rokasgrāmātā (tiek instalēta kopā ar programmu).
LT	Detalesnės informacijos ir saugos patarimų ieškokite vartotojo vadove (įdiegtame kartu su programine įranga).
EL	Για περισσότερες πληροφορίες και συστάσεις για την ασφάλεια, ανατρέξτε στον Οδηγό χρήσης (εγκαταστάθηκε μαζί με το λογισμικό).
TR	Ayrıntılı bilgi ve güvenlik önerileri için lütfen (yazılımla yüklenmiş olan) Kullanım Kılavuzu'na bakın.
SL	Podrobnejše informacije in varnostna priporočila najdete v uporabniškem priročniku (namesti se skupaj s programsko opremo).
HR	Detaljne informacije i preporuke o sigurnosti pogledajte u Korisničkom priručniku (instaliranom sa softverom).
MK	За подетални информации и препораки за безбедноста видете во „Корисничкиот прирачник“ (што се инсталира заедно со софтверот).
SR	Za detaljne informacije i mere bezbednosti pogledajte Korisničko uputstvo (instalirano zajedno sa softverom).
RU	Для получения подробных сведений и рекомендаций по безопасности см. Руководство пользователя (поставляется вместе с программным обеспечением).
AR	للحصول على معلومات مفصلة وتوصيات الأمان، ارجع إلى User's Guide (دليل المستخدم) (المثبت مع البرنامج)
FA	برای اطلاعات مشروح به راهنمای مراجعه (با نرم افزار نصب شده) رجوع شود.
CN	更多的信息和安全指导请参考《用户指南》手册。(与打印机软件一起被安装)
TW	關於詳細說明和安全建議事項，請參考與軟體同時安裝的使用手冊。
KR	자세한 정보 및 안전지시사항은 온라인 사용설명서를 참조하십시오. (소프트웨어와 함께 설치됩니다.)

DE: Mascinenlärminformations-Verordnung 3. GPSGV: Der höchste Schalldruckpegel beträgt 70 dB(A) oder weniger gemäß EN ISO 7779.

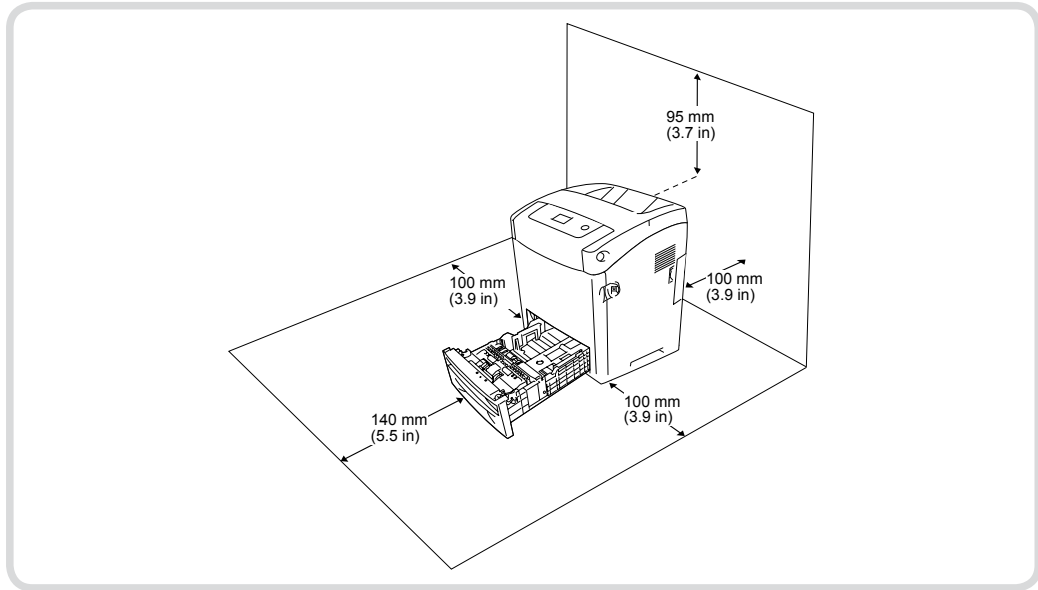
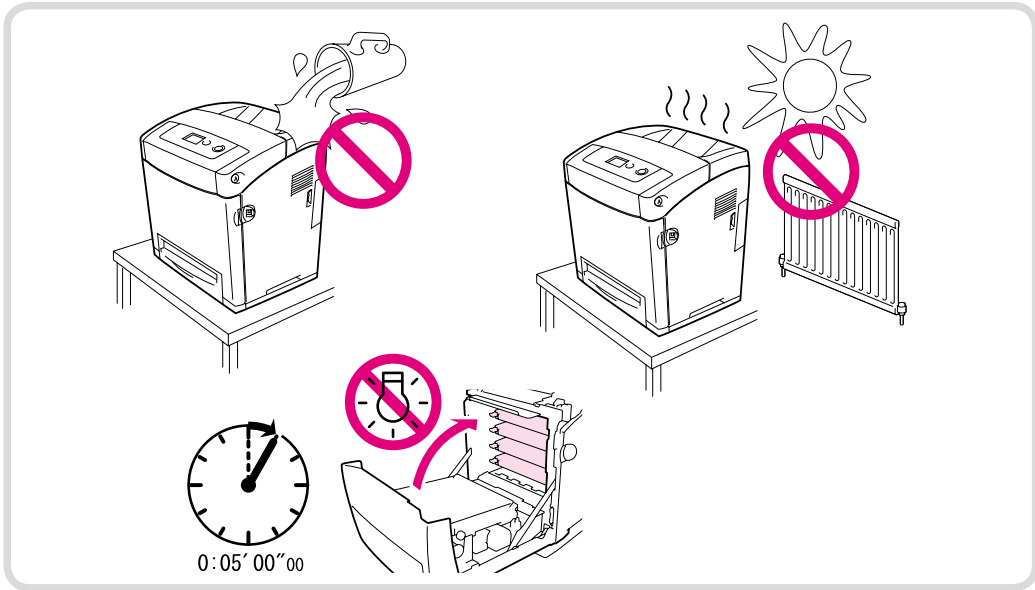
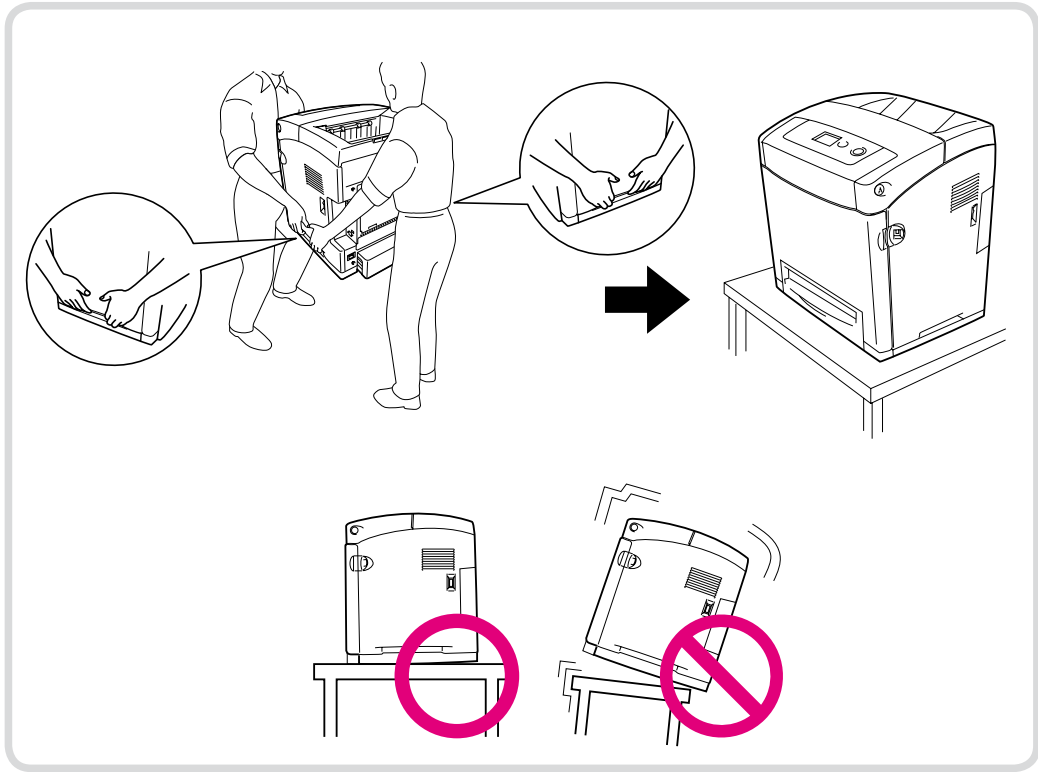
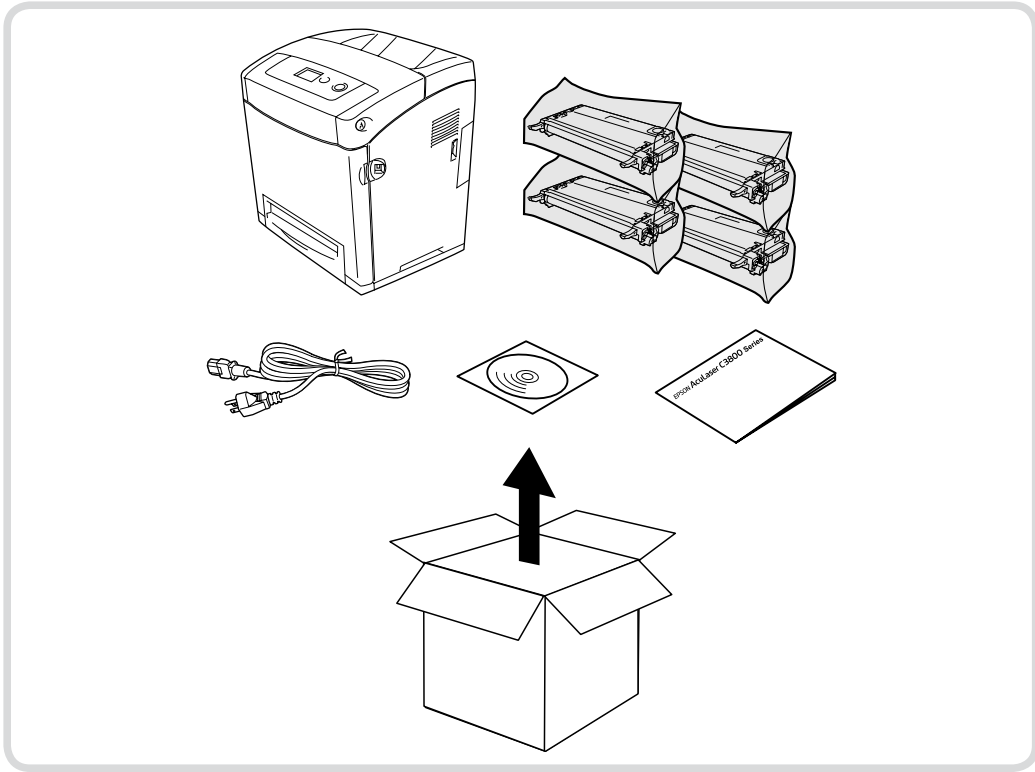

1

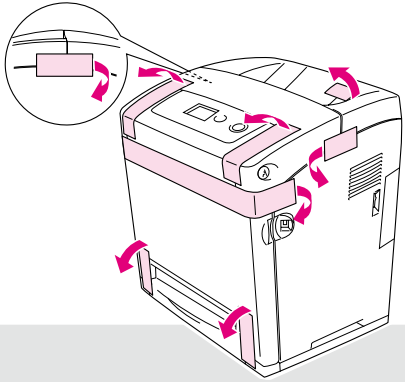

2

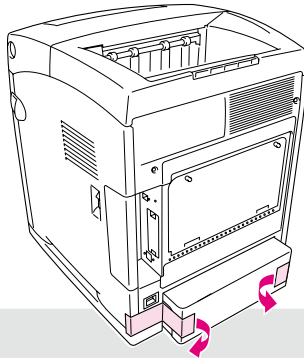

3

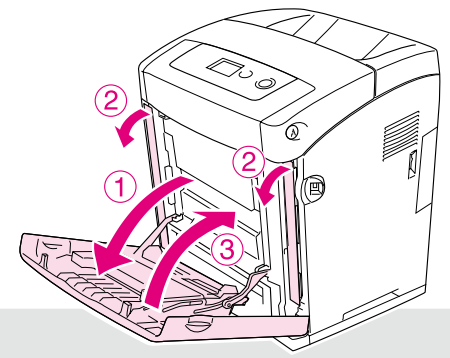

4

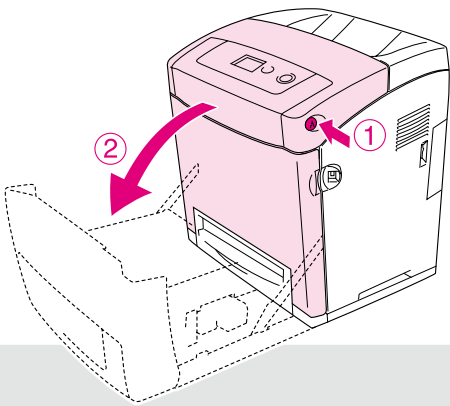

5

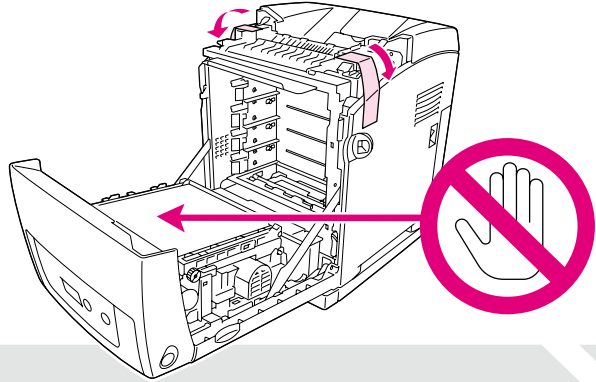

6

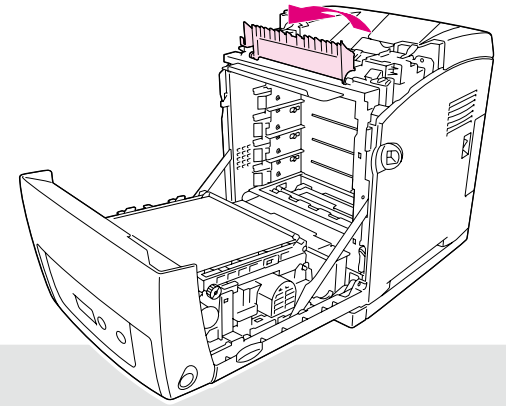

7

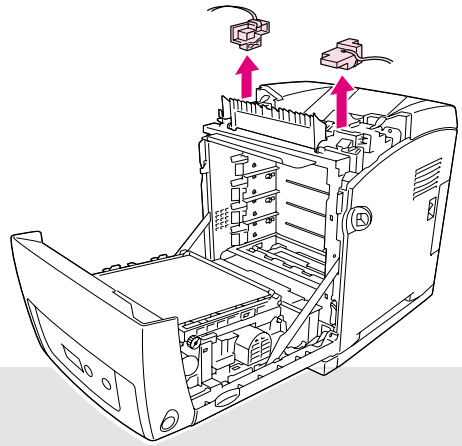

8

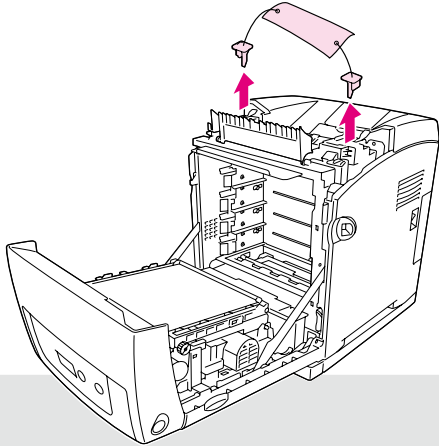

9

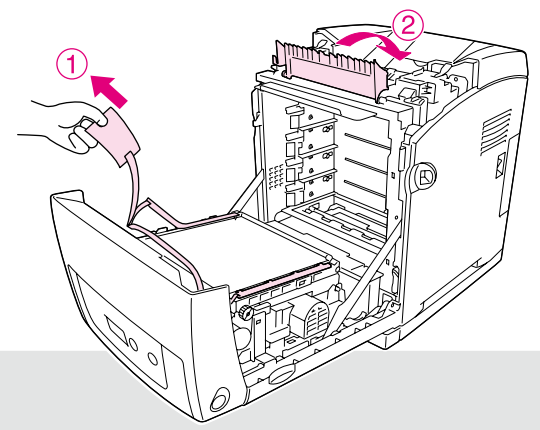

10

Yellow

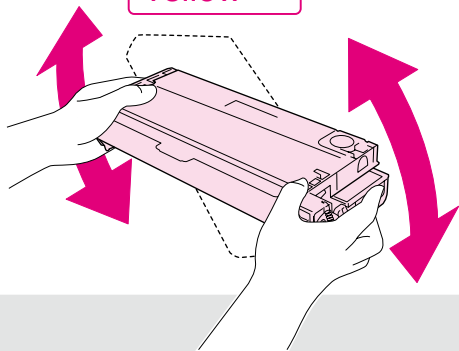

11

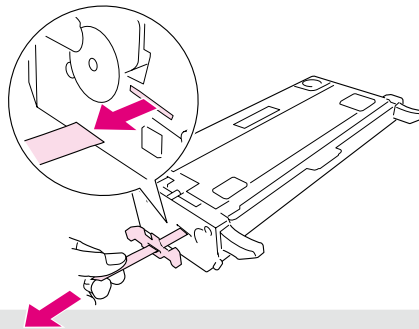

12

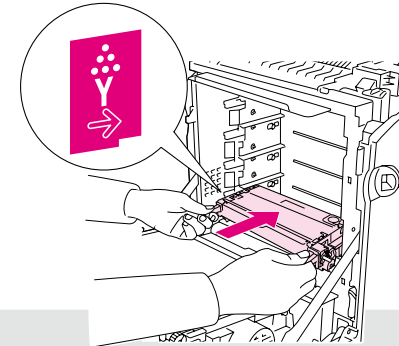

13

Magenta

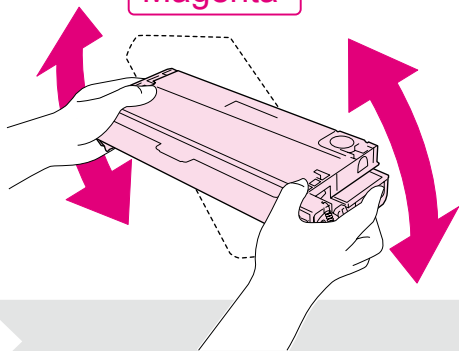

14

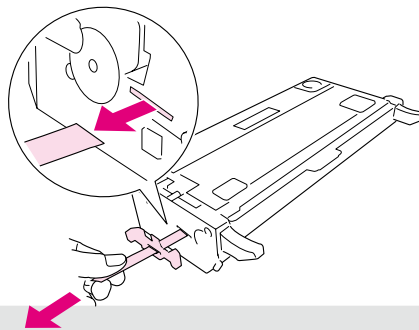

15

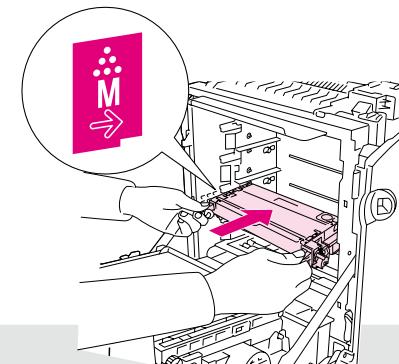

16

Cyan

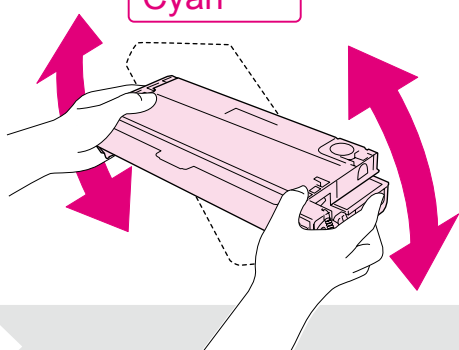

17

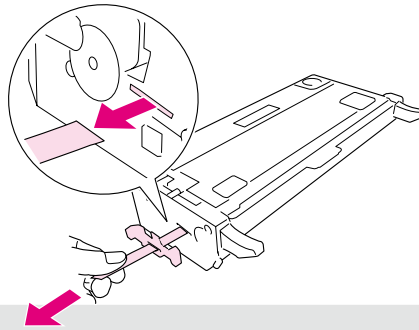

18

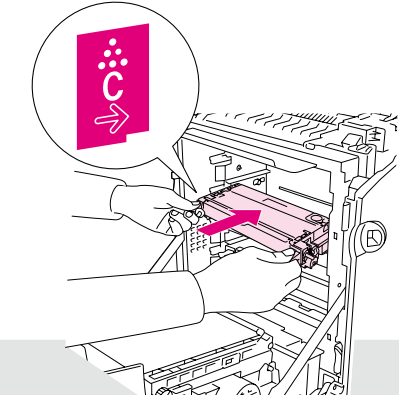

19

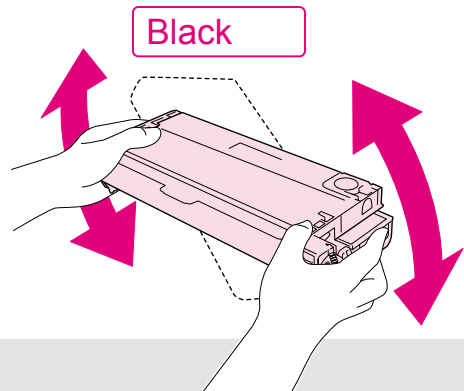

20

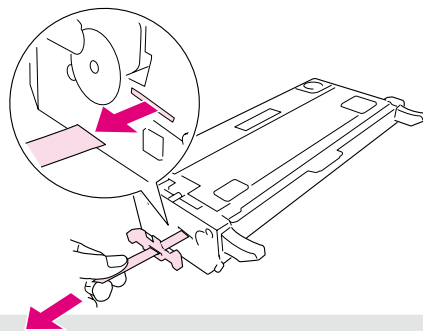

21

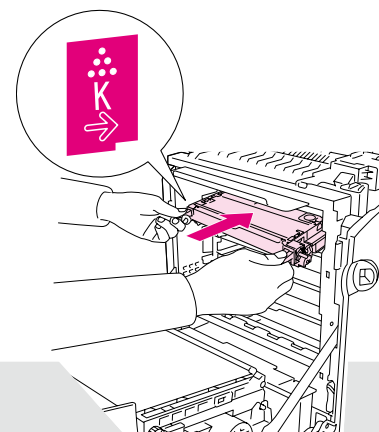

22

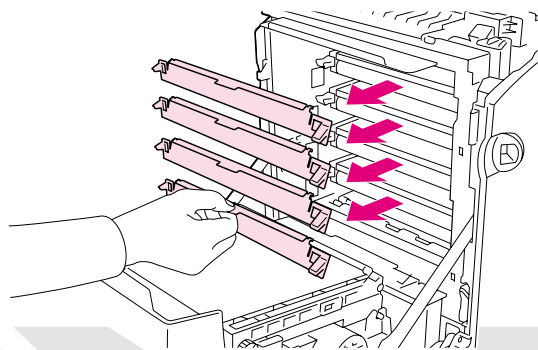

23

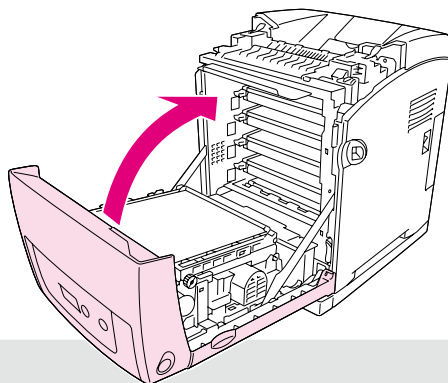

24

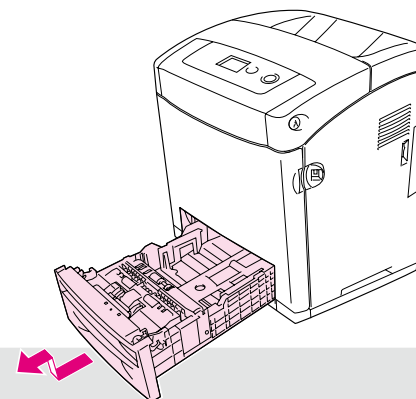

25

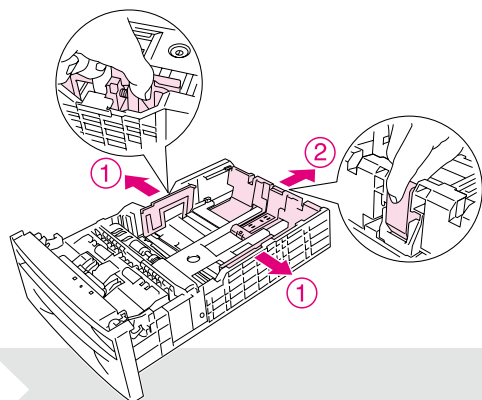

26

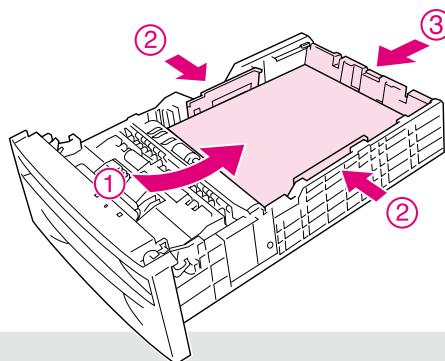

27

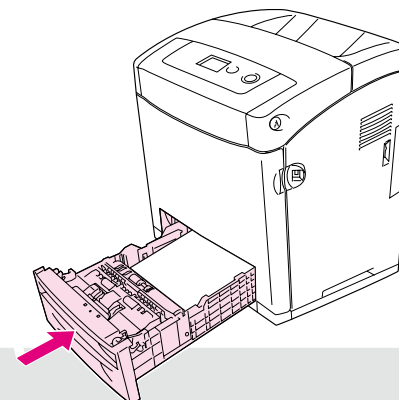

28

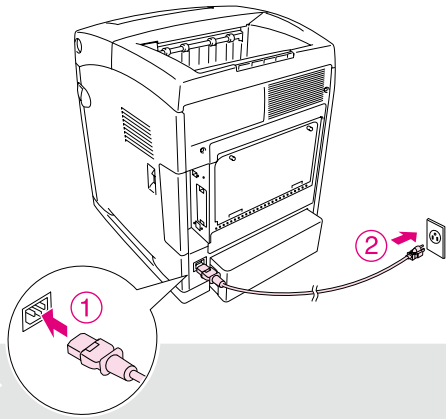

29

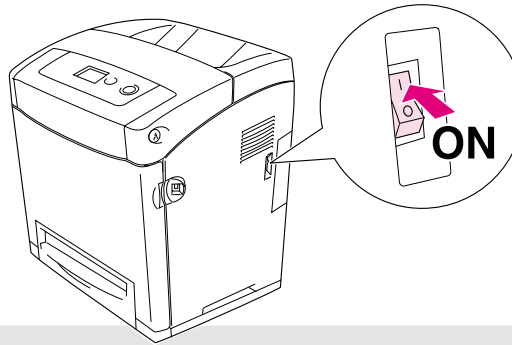

30

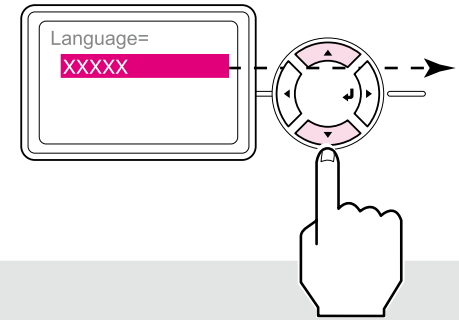

- | | |
|------------|-----------|
| English | SUOMI |
| Français | Português |
| Deutsch | Norsk |
| Italiano | CATALÀ |
| ESPAÑOL | Русский |
| SVENSKA | 中文 |
| Dansk | 繁體中文 |
| Nederlands | 한국어 |

31

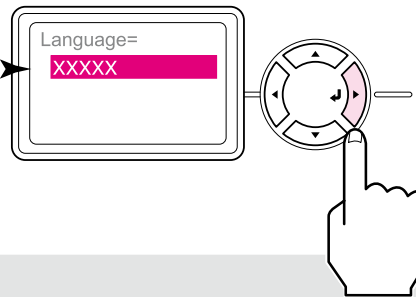

32

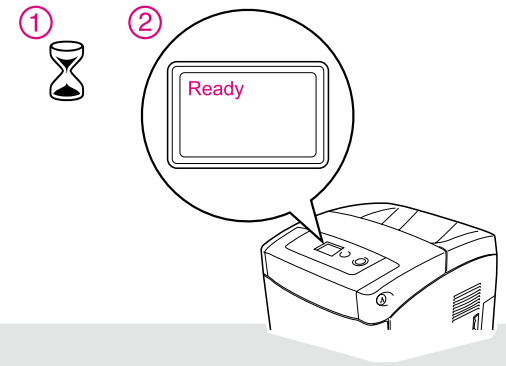

33

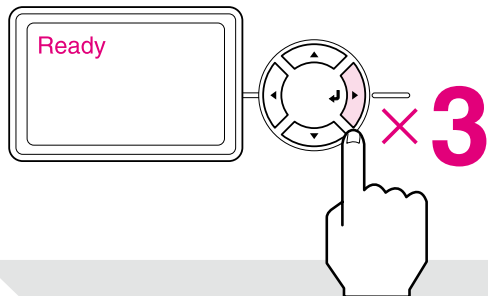

34

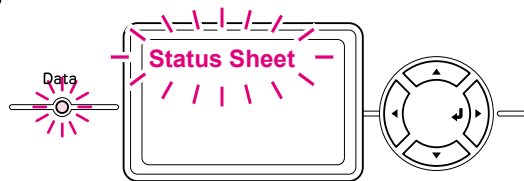

35

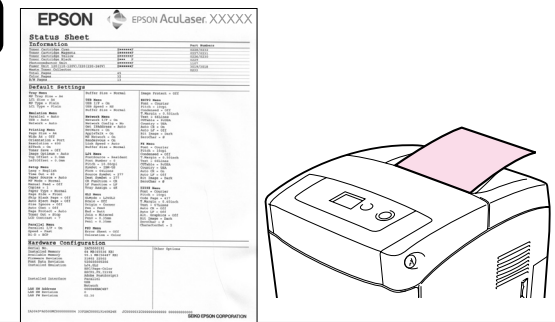

36 USB

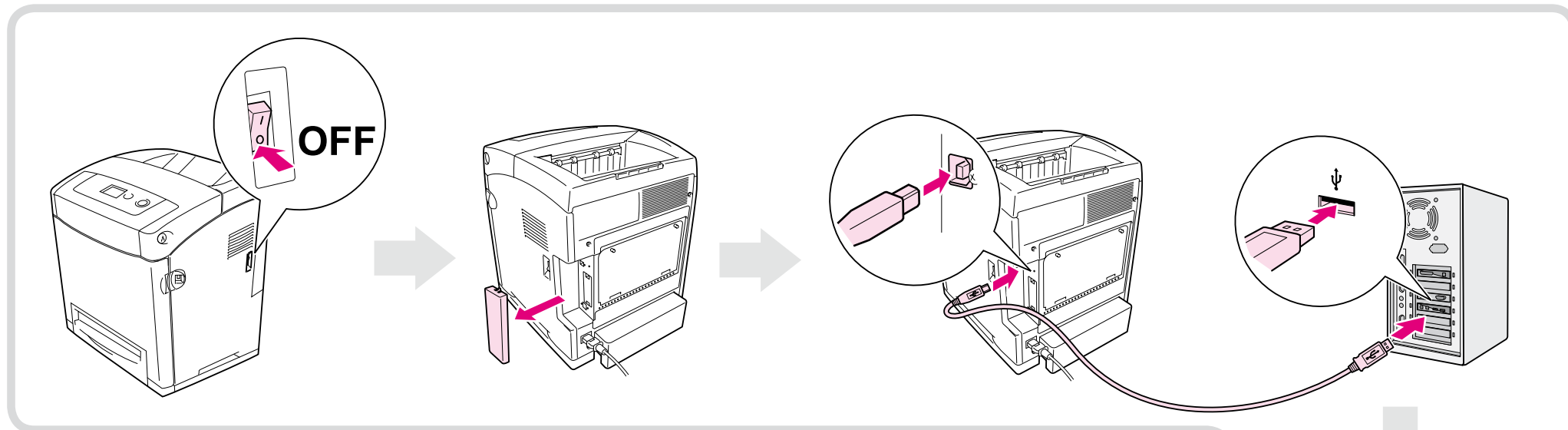

36 10/100 BaseTX

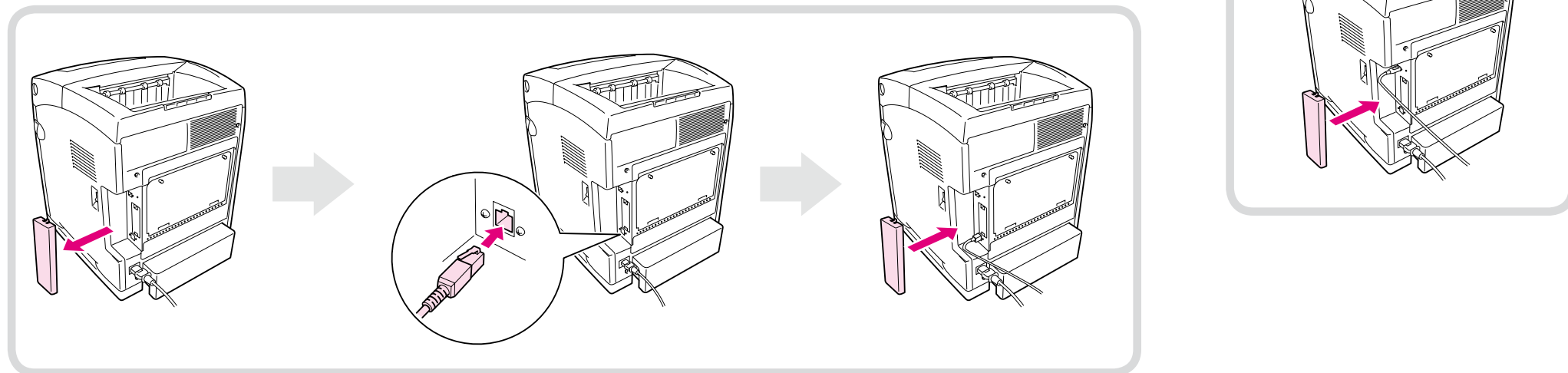

37 Windows

1

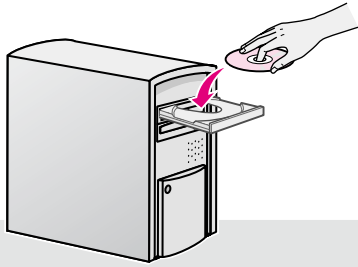

2



3

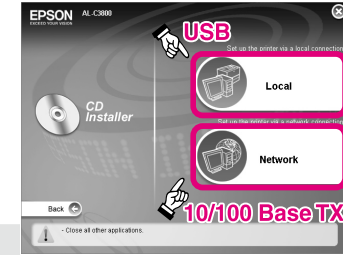

3

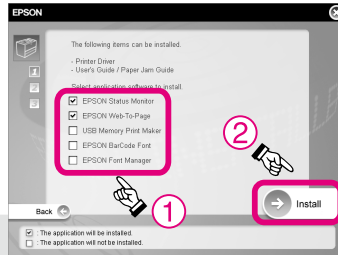

5

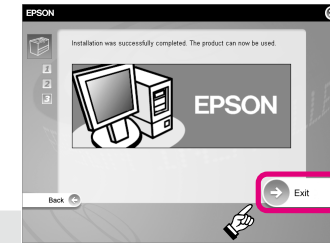

37 Mac OS

1

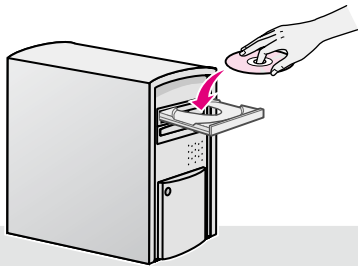

2

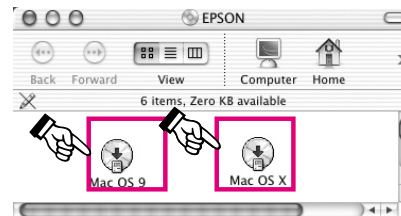

3



4



5

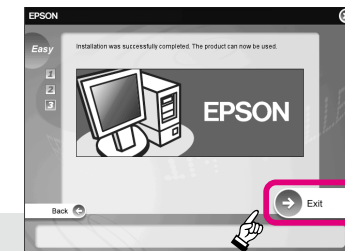

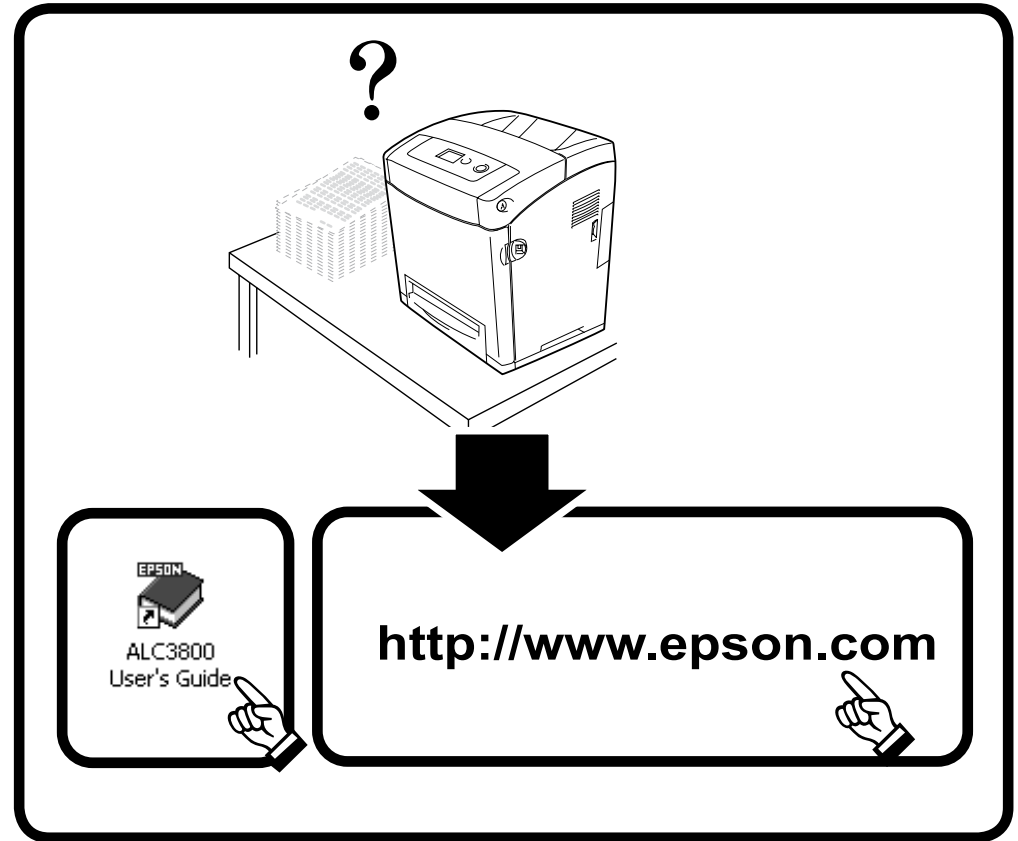
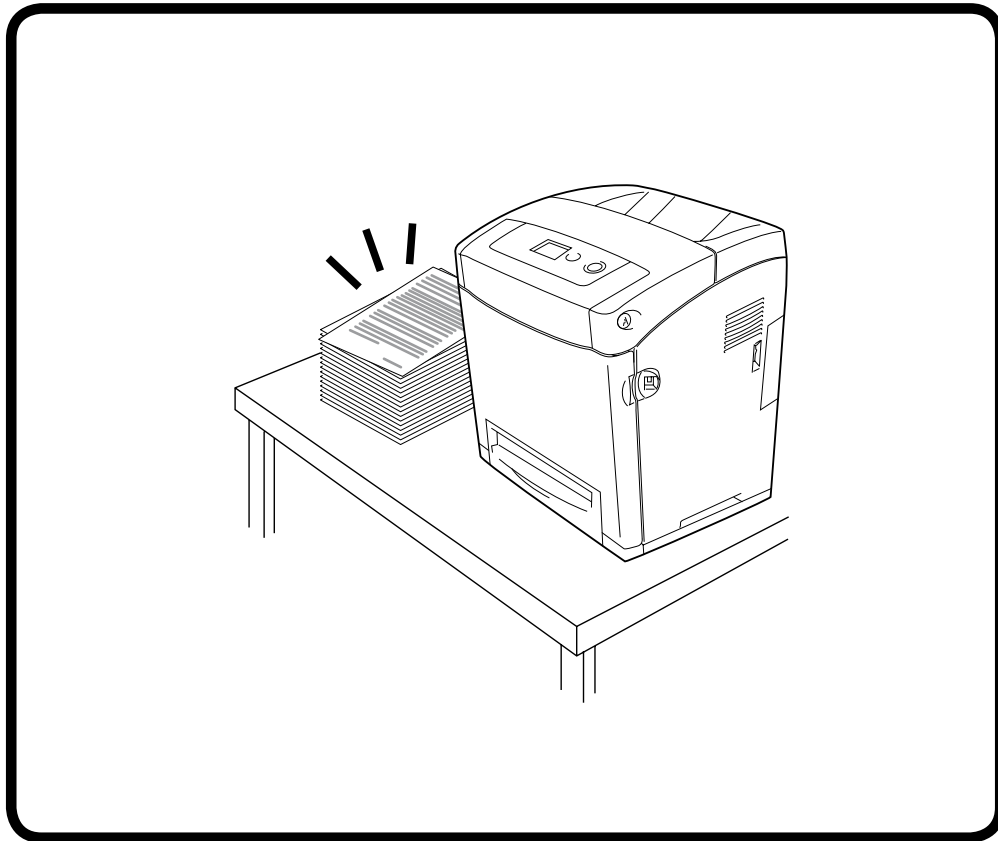

No part of this publication may be reproduced, stored in a retrieval system, or transmitted in any form or by any means, mechanical, photocopying, recording, or otherwise, without the prior written permission of Seiko Epson Corporation. No patent liability is assumed with respect to the use of the information contained herein. Neither is any liability assumed for damages resulting from the use of the information contained herein.

Neither Seiko Epson Corporation nor its affiliates shall be liable to the purchaser of this product or third parties for damages, losses, costs, or expenses incurred by purchaser or third parties as a result of: accident, misuse, or abuse of this product or unauthorized modifications, repairs, or alterations to this product, or (excluding the U.S.) failure to strictly comply with Seiko Epson Corporation's operating and maintenance instructions.

Seiko Epson Corporation and its affiliates shall not be liable against any damages or problems arising from the use of any options or any consumable products other than those designated as Original Epson Products or Epson Approved Products by Seiko Epson Corporation.

EPSON is a registered trademark and EPSON AcuLaser is a trademark of Seiko Epson Corporation.

Microsoft and Windows are registered trademarks of Microsoft Corporation in the United States and/or other countries.

Apple and Macintosh are registered trademarks of Apple Computer, Inc.

General Notice: Other product names used herein are for identification purposes only and may be trademarks of their respective owners. Epson disclaims any and all rights in those marks.

Copyright© 2006 Seiko Epson Corporation. All rights reserved.

Sicherheitsinformationen

Aufkleber zu Laserstrahlung



Vorsicht:

Die Durchführung von Verfahren und Einstellungen, die nicht in der Dokumentation zum Drucker aufgeführt sind, kann zu gefährlicher Strahlenbelastung führen.

Dieser Drucker ist ein Laserprodukt der Klasse 1 gemäß der Definition in den IEC60825-Spezifikationen. Der abgebildete Aufkleber ist in Ländern, in denen dies erforderlich ist, an der Rückseite des Druckers angebracht.



Interne Laserstrahlung

Max. durchschnittliche Strahlungsleistung: 5 mW an der Laseröffnung
Wellenlänge: 770 bis 800 nm

Dies ist eine Laserdioden-Baugruppe der Klasse III mit einem unsichtbaren Laserstrahl. Der Druckkopf ist KEINE WARTBARE VORRICHTUNG, daher darf die Druckkopfeinheit unter keinen Umständen geöffnet werden. Im Inneren des Druckers ist ein zusätzlicher Aufkleber zur Laserstrahlung angebracht.

Ozon-Sicherheit

Ozonemission

Laserdrucker erzeugen Ozongas als Nebenprodukt des Druckprozesses. Ozon wird nur erzeugt, während der Drucker druckt.

Ozon-Belastungsgrenze

Die empfohlene Belastungsgrenze für Ozon beträgt 0,1 Teile pro Million (ppm), ausgedrückt als eine durchschnittliche, zeitlich gewichtete Konzentration über einen Zeitraum von acht (8) Stunden.

Der Epson-Laserdrucker erzeugt weniger als 0,1 ppm bei acht (8) Stunden Dauerdruckbetrieb.

Risiko minimieren

Um das Risiko der Ozonbelastung minimal zu halten, sollten Sie die folgenden Bedingungen vermeiden:

- ❑ Einsatz von mehreren Laserdruckern in einem abgeschlossenen Bereich
- ❑ Betrieb bei extrem niedriger Luftfeuchtigkeit
- ❑ Schlechte Raumventilation
- ❑ Langer kontinuierlicher Druckbetrieb in Verbindung mit einer der obigen Bedingungen

Aufstellplatz des Druckers

Der Drucker sollte so aufgestellt werden, dass erzeugte Abgase und Wärme:

- ❑ nicht direkt auf das Gesicht des Benutzers gerichtet sind
- ❑ nach Möglichkeit direkt aus dem Gebäude ins Freie geleitet werden

EPSON
EXCEED YOUR VISION

Printed in XXXXXX XX.XX-XX XXX



410620600