

EPSON

PhotoPC
800

EPSON

Color Digital Camera

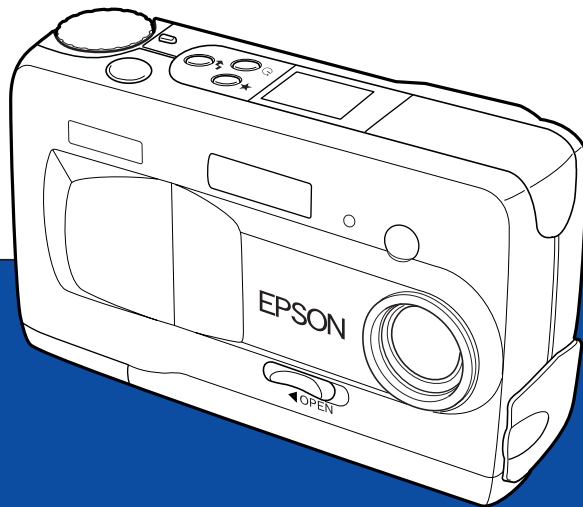

User's Guide

PhotoPC 800
User's Guide

Where to Find Information

This User's Guide

Provides detailed information on using your EPSON PhotoPC 800, the Direct Print program, and optional products; from setting up to troubleshooting.

EPSON Photo!3/EPSON Photo File Uploader3 User's Guide

Provides information on EPSON Photo!3 software which is necessary for using the photos on your computer, and uploading utilities including EPSON Photo File Uploader3.

Online Help

Provides detailed information and instructions for EPSON Photo!3 that controls your PhotoPC 800. Online help is installed automatically when you install EPSON Photo!3. See the *EPSON Photo!3 User's Guide* for information on accessing online help.

Color Guide (included in the CD-ROM in some locations)

Explains the basics of color imaging and shows you how to get the most from your PhotoPC 800 and other EPSON products. See "Viewing the Color Guide" on page 2-29 of this *User's Guide* for information on accessing the *Color Guide*.

EPSON®

PhotoPC₈₀₀

COLOR DIGITAL CAMERA



Printed on Recycled Paper.

User's Guide

IMPORTANT NOTICE

All rights reserved. No part of this publication may be reproduced, stored in a retrieval system, or transmitted in any form or by any means, electronic, mechanical, photocopying, recording, or otherwise, without the prior written permission of SEIKO EPSON CORPORATION. No patent liability is assumed with respect to the use of the information contained herein. Neither is any liability assumed for damages resulting from the use of the information contained herein.

Neither SEIKO EPSON CORPORATION nor its affiliates shall be liable to the purchaser of this product or third parties for damages, losses, costs, or expenses incurred by the purchaser or third parties as a result of: accident, misuse, or abuse of this product or unauthorized modifications, repairs, or alterations to this product, or (excluding the U.S.) failure to strictly comply with SEIKO EPSON CORPORATION's operating and maintenance instructions.

SEIKO EPSON CORPORATION shall not be liable against any damages or problems arising from the use of any options or any consumable products other than those designated as Original EPSON Products or EPSON Approved Products by SEIKO EPSON CORPORATION.

EPSON is a registered trademark of SEIKO EPSON CORPORATION. PhotoPC is a trademark of SEIKO EPSON CORPORATION. Macintosh is a registered trademark of Apple Computer, Inc. Microsoft and Windows are registered trademarks of Microsoft Corporation. CompactFlash is a trademark of SanDisk Corporation and has been licensed to CFA (CompactFlash Association).

General Notice: Other product names used herein are for identification purposes only and may be trademarks of their respective owners. EPSON disclaims any and all rights in those marks.

Copyright©1999 by SEIKO EPSON CORPORATION, Nagano, Japan.

Declaration of Conformity

According to ISO/IEC Guide 22 and EN 45014

Manufacturer: SEIKO EPSON CORPORATION
Address: 3-5, Owa 3-chome, Suwa-shi,
Nagano-ken 392-8502 Japan
Representative: EPSON EUROPE B.V.
Address: Prof. J. H. Bavincklaan 5 1183 AT Amstelveen
The Netherlands

Declares that the Product:

Product Name: Digital Still Camera
Model: G760A

Conforms to the following Directive(s) and Norm(s):

Directive 89/336/EEC:
EN 55022 Class B
EN 50082-1
IEC 801-2
IEC 801-3
IEC 801-4

May, 1999

H. Horiuchi
President of EPSON EUROPE B.V.

A NOTE CONCERNING RESPONSIBLE USE OF COPYRIGHTED MATERIALS

Like photocopiers, digital cameras can be misused by improper photographing of copyrighted material. Unless you have the advice of a knowledgeable attorney, be responsible and respectful by obtaining the permission of the copyright holder before photographing published material.

Contents

Introduction

PhotoPC 800 Features	1
Options.	2
For United Kingdom users - use of options	3
Safety Instructions	3
When using the camera	3
When using the hand strap.	4
When using the charger and batteries.	4
Warnings, Cautions, and Notes	6

Chapter 1 Getting Started

Unpacking Your PhotoPC 800	1-1
Camera Parts.	1-2
Using the Batteries	1-4
Charging the batteries	1-4
Installing the batteries	1-6
Replacing the batteries.	1-7
Handling the batteries.	1-7
Storing the batteries	1-8
Disposing of the batteries	1-8

Setting Up Your Camera	1-9
Attaching the hand strap to your camera	1-9
Installing and removing a CompactFlash Card	1-9
Setting the language	1-10
Setting the date and time	1-11

Chapter 2 Taking Pictures

Getting Ready	2-1
Your camera's picture-taking range.	2-1
Checking the display panel	2-2
Using the dial switch	2-3
Making basic settings	2-4
Taking Pictures Using the Viewfinder.	2-4
Using the self timer.	2-6
Making Settings in the Viewfinder Dial Position.	2-7
Adjusting the image quality	2-7
Setting the flash	2-8
Adjusting the sensitivity setting.	2-9
Adjusting the white balance setting.	2-9
Adjusting the exposure setting	2-10

Taking Pictures Using the LCD monitor	2-10
Using the digital zoom feature	2-11
Using the macro setting to take close-ups	2-12
Taking panoramas	2-12
Making Settings in the LCD Monitor Dial Position	2-13
Making a predefined exposure setting	2-13
Adjusting the white balance setting	2-14
Adjusting the sensitivity setting	2-15
Making basic exposure adjustments	2-16
Making advanced exposure adjustments	2-17
Making manual focus settings	2-18
Changing the metering system	2-19
Taking Multiple Exposures	2-20
Using the continuous shooting feature	2-20
Using the time lapse feature	2-21
Making Audio Recordings for Photos	2-22
Right after taking photos	2-22
For existing photos	2-23
Making Additional Settings	2-24
Setting the time and date	2-24
Making the camera mode setting	2-24
Changing the color/monochrome setting	2-25
Quick shooting feature	2-26
Setting the automatic shut-off feature	2-26
Setting the LCD monitor's brightness	2-27
Setting the beep	2-27
Making user settings for white balance	2-28
Selecting the language	2-28
Selecting a folder in the CompactFlash Card	2-29

Viewing the Color Guide	2-29
-----------------------------------	------

Chapter 3 Viewing and Managing Your Photos

Viewing Photos with the LCD Monitor	3-1
Displaying multiple photos	3-1
Magnifying photos	3-2
Viewing a slide show of your photos	3-3
Viewing photo information	3-5
Managing Photos with the LCD Monitor	3-5
Erasing photos	3-5
Locking and unlocking photos	3-7
Erasing audio recordings	3-8
Using Your Computer	3-9
Viewing Pictures on a Television	3-10
Viewing Pictures with an EPSON Projector	3-11

Chapter 4 Using Direct Print to Print Photos

Features	4-1
Requirements	4-2
Connecting your camera to the printer	4-3
Installing the Direct Print Program	4-4
Printing Your Images	4-5
Accessing the Direct Print program	4-5
Choosing a print format	4-6
Printing procedures	4-8
Printing the photos	4-10

LCD Monitor and Display Panel Messages	4-11
Printed Image Dimensions	4-13

Chapter 5 Camera Options and Accessories

Using CompactFlash Memory Cards	5-1
Installing a CompactFlash Card into your computer	5-2
Copying photos directly to a computer	5-3
Copying or deleting programs using a CompactFlash Card	5-4
Formatting memory cards	5-5
Using the AC Adapter	5-6

Chapter 6 Maintenance and Troubleshooting

Maintenance	6-1
Handling the camera	6-1
Cleaning the camera	6-2
Storing the camera	6-2
Cleaning the battery charger	6-2
Problems and Solutions	6-3
Camera problems	6-3
Picture problems	6-7

Appendix A Specifications



Camera	A-1
Physical dimensions	A-1
Product type	A-1
Recorded image	A-2
Optical	A-3
Functional	A-4
Interface	A-4
Power	A-4
CompactFlash Card	A-6
Optional PCMCIA Adapter	A-6
Optional AC Adapter	A-7

Appendix B Contacting Customer Support

For United Kingdom and the Republic of Ireland Users	B-1
World Wide Web	B-1
Faxon EPSON	B-2
Bulletin Board Service for latest drivers and utilities	B-2
Customer and Warranty Support	B-2
Pre Sales Enquiry Desk	B-3

For Australian Users	B-3
EPSON FAXBACK.	B-3
EPSON Bulletin Board System.	B-3
Internet URL http://www.epson.com.au	B-4
Your dealer	B-4
EPSON Helpdesk.	B-4
For Singapore Users.	B-4
For Hong Kong Users	B-4
Internet home page	B-5
Electronic bulletin board system	B-5
Technical Support Hotline	B-5
For Philippines Users	B-5

Appendix C Dial Position Settings

Available settings in the  dial position.	C-2
Available settings in the  dial position.	C-3
Available settings in the  dial position	C-3
When using the Program camera mode.	C-3
When using the Manual camera mode.	C-4

Glossary

Index

Introduction

Your new EPSON® PhotoPC™ 800 is a revolutionary, easy-to-use digital camera that enables you to take full-color pictures for use with your computer. The PhotoPC 800 comes with everything you need, including EPSON Photo!3 software that lets you transfer your pictures to your computer's hard disk. You can then edit, enhance, and organize your pictures, or simply place them into your documents. To use EPSON Photo!3, see the *EPSON Photo!3/EPSON Photo File Uploader3 User's Guide*.

Create professional letters, documents, and presentations with real life images right on your desktop. Share pictures with business colleagues or friends over the Internet. Add color and visual appeal to your newsletters, flyers, and brochures. Anything you can print out or display on your screen will look better with images from your PhotoPC 800.

PhotoPC 800 Features

PhotoPC 800 is a complete system for capturing digital images, and includes the following features.

- ❑ 2.1 Mega pixel CCD (can be enhanced to 3.0 Mega pixel with HyPict)
- ❑ 24-bit color image capture
- ❑ High resolution (1600×1200 pixels, or 1984×1488 pixels with HyPict)
- ❑ Built-in color LCD monitor for previewing and playing back pictures
- ❑ Built-in microphone for audio recordings
- ❑ Macro, digital 2× zoom, and panorama photo formats
- ❑ Continuous shooting of up to ten pictures in sequence
- ❑ Automatic, predefined, or manual white balance

- ❑ Automatic, predefined and adjustable exposure settings (-2.0 to + 2.0 EV, in increments of 0.5 or 0.2)
- ❑ Automatic date and time recording for each picture
- ❑ Built-in flash with automatic flash, forced flash, flash off, and Slow Synchro Flash (for taking pictures at night or in dark places)
- ❑ Self timer (ten seconds)
- ❑ Automatic shut-off setting to save batteries
- ❑ EPSON Photo!3 software that lets you transfer your pictures to your computer
- ❑ EPSON Photo File Uploader3 software that allows you to convert images stored in your computer to EPSON Photo file format and upload them to your camera
- ❑ EPSON Program Uploader software that lets you upload optional programs to the camera from your computer
- ❑ Pictures compatible with both Windows® and Macintosh® applications

Options

The following PhotoPC 800 options are available from EPSON.

- ❑ CompactFlash™ cards
(For information, contact your EPSON dealer.)
- ❑ PCMCIA adapter (B867041)
- ❑ AC Adapter (B86706*) for use with a standard electrical outlet
- ❑ Power Pack (B81817*) which includes:
Ni-MH Battery Charger
Four Ni-MH Rechargeable Batteries
- ❑ Package of four Ni-MH Rechargeable Batteries (B81811*)

Note:

- ❑ *The asterisk is a substitute for the last digit of the product number, which varies by country.*
- ❑ *The PhotoPC 800 comes with a Power Pack (described above), and an 8 MB CompactFlash Card.*

- ❑ *The AC Adapter model EU-37, and Battery Charger model EU-38, conform to CE marking requirements in accordance with EC Directives 73/23/EEC and 89/336/EEC.*

For United Kingdom users - use of options

EPSON (UK) LTD shall not be liable against any damages or problems arising from the use of any options or consumable products other than those designated as Original EPSON Products or EPSON Approved Products by EPSON (UK) LTD.

Safety Instructions

Read all these instructions and save them for later reference. Follow all warnings and instructions marked on the camera and options.

When using the camera

- ❑ To reduce the risk of electric shock, do not remove the cover of the camera or options and do not open any compartments except as instructed in this *User's Guide*.

- ❑ Do not insert objects into any openings.
- ❑ To prevent fire or electric shock, do not expose the camera or options to rain or moisture.
- ❑ To prevent fire or electric shock, do not cover the camera with a blanket.
- ❑ To prevent fire or explosion, do not use the camera where flammable or volatile gas is stored.
- ❑ Do not use outdoors during a thunderstorm.
- ❑ If the camera or option shows unusual signs such as noise, odor, or smoke, stop usage and turn off immediately. Remove the batteries and/or disconnect the AC adapter from the camera, and unplug the AC adapter from the electrical outlet.
- ❑ To prevent possible injury, do not take flash pictures close to the subject's eyes.
- ❑ Use only the type of power source indicated in this *User's Guide*.
- ❑ Do not use damaged or frayed power cords.
- ❑ Remove the batteries and/or plug from the camera and refer servicing to qualified service personnel in the following circumstances:

The power cord or plug is damaged; liquid has entered the camera or options; the camera or options have been dropped or the case damaged; the camera or options do not operate normally or exhibit a distinct change in performance.

- ❑ Never adjust controls that are not mentioned in the operating instructions.
- ❑ If you plan to use the camera and options in Germany, observe the following:

To provide adequate short-circuit protection and over-current protection for the products, the building installation must be protected by a 16 Amp circuit breaker.

Bei Anschluß des Produkts an die Stromversorgung muß sichergestellt werden, daß die Gebäudeinstallation mit einem 16 A-Überstromschalter abgesichert ist.

- ❑ If the liquid crystal solution contained in the display panel or in the screen on the LCD monitor leaks out and gets on your hands, wash them thoroughly with soap and water. If it gets into your eyes, flush them immediately with water.

When using the hand strap

- ❑ Do not swing the camera about. This can damage the camera or other objects, or injure others.
- ❑ Do not pull or tighten the strap too firmly while wearing it around your hand; this can cause serious injury.
- ❑ Keep the strap away from children.

When using the charger and batteries

- ❑ Read all relevant safety and operating instructions before using these products.
- ❑ Use only the EPSON Ni-MH Battery Charger, Model EU-38 to charge the EPSON Ni-MH Batteries Model EU-24. Never attempt to charge other types of batteries in this charger as they may explode, leak, overheat, or cause personal injury.
- ❑ Do not charge primary (non-rechargeable) batteries.
- ❑ Use the type of power source indicated on the charger's label. Always supply power directly from a standard domestic electrical outlet.

- ❑ Be sure your AC power cord meets relevant safety standards of the area where you plan to use it.
- ❑ Do not use the batteries or charger near water or handle them with wet hands.
- ❑ Unplug the charger if the batteries are not fully charged after four hours.
- ❑ Power-supply cords should be protected from abrasion, cuts, crimping and kinking. Be sure to place your cords to avoid any damage. Do not place objects on top of the power cord or allow the power cord to be stepped on or run over. You should take special care to try to keep the power cord straight at the ends and the points where it enters and leaves the transformer.
- ❑ Unplug your equipment from the wall outlet and refer servicing to qualified personnel under the following conditions:

If the power cord or plug is damaged; if liquid has entered your equipment; if your equipment has been exposed to rain or water; if your equipment has been dropped or damaged; if your equipment is operating abnormally or exhibits a distinct change in performance. Adjust only those controls described in your product documentation.
- ❑ Do not attempt to service the charger yourself. Refer all servicing to qualified service personnel.
- ❑ Keep away from heat sources. Use the charger within the temperature range of 5°C to 35°C (41°F to 95°F).
- ❑ Do not insert batteries into the charger backward as they may explode, leak, overheat, or cause personal injury.
- ❑ Do not insert objects into any openings as they may touch dangerous voltage points or short out parts.
- ❑ Never disassemble or modify the charger.
- ❑ Use charger in a dry, indoor location.
- ❑ Do not expose batteries or the charger to water or high humidity.
- ❑ Keep the charger out of reach of children.
- ❑ Only use the batteries in EPSON Digital Cameras as specified in this manual.
- ❑ Never use EPSON Ni-MH batteries in combination with any other type of batteries.

- ❑ To guard against short-circuiting, do not remove the outside sleeves of the batteries.
- ❑ Beware of electrical shock hazard.
- ❑ If battery acid gets into your eyes or on your skin, immediately rinse the affected area thoroughly with water and seek medical treatment. If a battery is swallowed, seek medical treatment immediately.
- ❑ Never use EPSON Ni-MH batteries in combination with any other type of batteries, and always use batteries from the same package as a set. Do not mix old and new batteries, or charged and discharged batteries.
- ❑ Do not use manganese batteries.
- ❑ Keep the batteries from making contact with metal objects such as coins or keys, which could short circuit the batteries.
- ❑ Do not drop, puncture, disassemble, mutilate, or short circuit batteries. Do not put the batteries near or into fire or water.
- ❑ Do not insert batteries into wall outlets or other power sources such as a car cigarette lighter socket.
- ❑ Do not solder lead wires or terminals directly to a battery.
- ❑ To avoid fire or electric shock, do not use batteries that are leaking or damaged in any way.
- ❑ To prevent fire or electric shock, do not cover the charger with a blanket.
- ❑ To prevent fire or explosion, do not use the charger where flammable or volatile gas is stored.

Warnings, Cautions, and Notes



Warnings must be followed carefully to avoid bodily injury.



Cautions must be observed to avoid damage to your equipment.

Notes contain important information and useful tips on the operation of your camera and options.

This chapter prepares you to use your PhotoPC 800 and covers the following topics.

Unpacking your PhotoPC 800

Camera parts

Charging, installing and replacing batteries

Installing the CompactFlash Card

Attaching the hand strap

Setting the language, date and time for your camera

Unpacking Your PhotoPC 800

Make sure you have everything shown below.

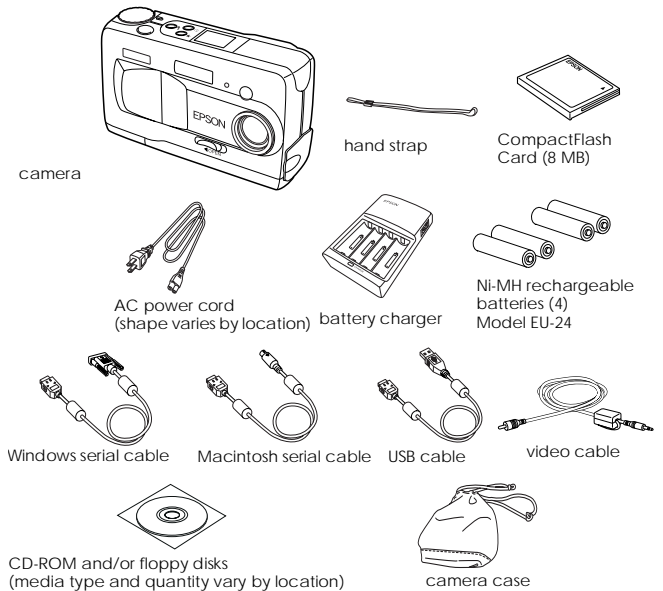

Camera Parts

After you unpack your PhotoPC 800, take a few minutes to learn about its features, as shown below.

Front view

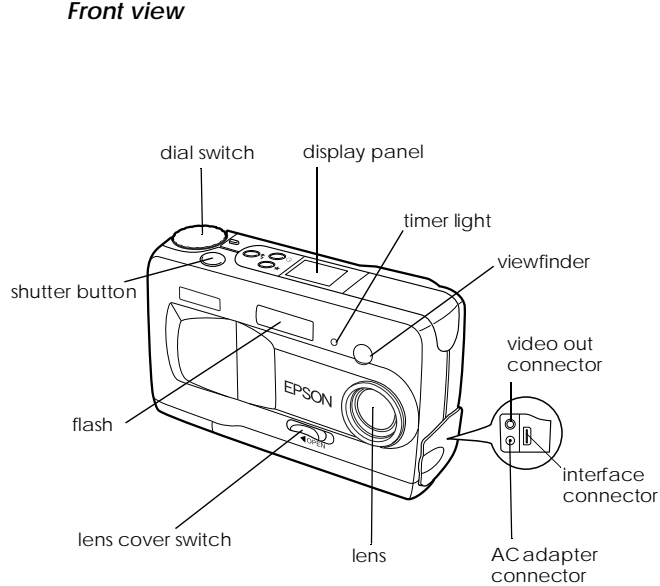

Back view

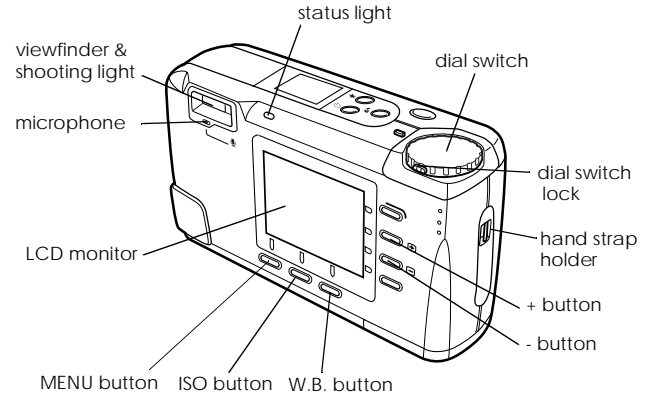

Bottom view

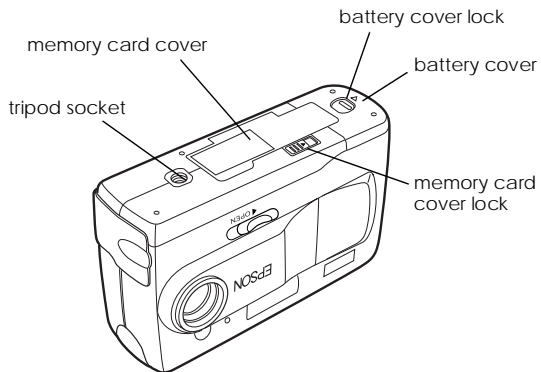

Top view

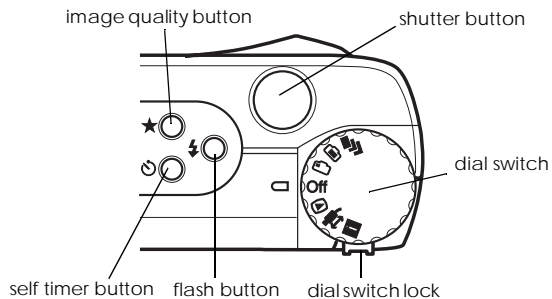

Display panel

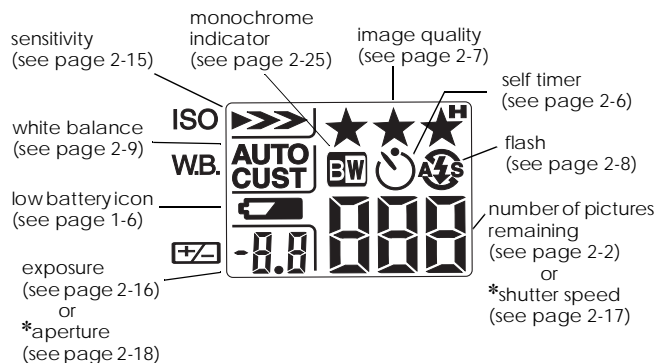

* When shutter is pressed half-way and Program or Manual camera mode is selected.

Using the Batteries

Your PhotoPC 800 comes with four Ni-MH rechargeable batteries (Model EU-24) and the Ni-MH Battery Charger (Model EU-38). Be sure to charge your new rechargeable batteries before installing them in the camera.

Keep the following points in mind when using these batteries.

- ❑ To fully charge new batteries or batteries that have not been used for a long time, you may have to charge them two or three times.
- ❑ Use batteries regularly so that they continue to charge well. Batteries which have not been used for a long time will return to normal with regular use.
- ❑ Discharge batteries completely before recharging them. If your batteries are not completely drained of power, you may not be able to recharge them fully.
- ❑ Batteries charged in a hot environment wear out more quickly.

- ❑ Do not leave batteries in a camera or charger for a long time without use. See “Storing the batteries” on page 1-8 for storage instructions.
- ❑ Rechargeable batteries wear out with repeated use; as their charging capacity decreases, your camera’s operating time decreases. Replace the batteries when their operation time becomes short.

Charging the batteries

The Ni-MH Battery Charger charges your Ni-MH rechargeable batteries quickly to last longer in your camera.

Before charging your batteries, be sure to read the safety instructions in “When using the charger and batteries” on page 4.



Warning:

- ❑ *Do not mix different types of batteries; this can cause fire or explosion.*
- ❑ *Always use batteries from the same package as a set. Do not mix old and new batteries.*

Follow these steps to charge your Ni-MH batteries.

1. Install the batteries into the compartments, positioning the + and - ends as shown.



Caution:

Install and charge two or four batteries at a time for your camera.

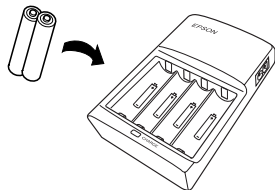

2. Connect the battery charger to the power cord as shown below.

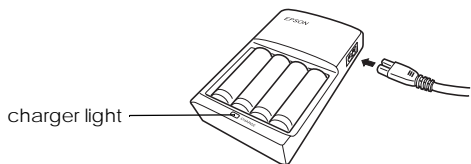

3. Plug the charger into an electrical outlet. The charger light turns red indicating that the charger is working.



Caution:

Be sure to insert all plugs and connectors firmly and completely.

4. When the batteries are fully charged, the light goes off. To charge your batteries again, unplug the AC power cord, then plug it in again.

Note:

Replace the batteries with new Ni-MH batteries in the following cases: the charger light stays on for more than 120 minutes (for 2 batteries), or 240 minutes (for 4 batteries); the charger light flashes for more than half an hour.

5. After the light goes off, unplug the charger. To avoid overcharging, do not leave the charger plugged in for long periods of time after the light goes off.
6. After the batteries cool, remove them from the charger.



Warning:

Batteries are very hot (approximately 65°C) during and just after charging. Wait one hour for the batteries to cool before handling.

7. Before storing the charger, disconnect the AC power cord and remove the batteries.

Installing the batteries

Before installing the batteries, be sure to read the safety instructions in “When using the charger and batteries” on page 4.

Make sure the camera is off, and follow these steps to insert or replace the batteries.

1. Turn the camera upside down with the lens facing you. Hold the PUSH button down and slide the battery cover to the right to open the battery cover.

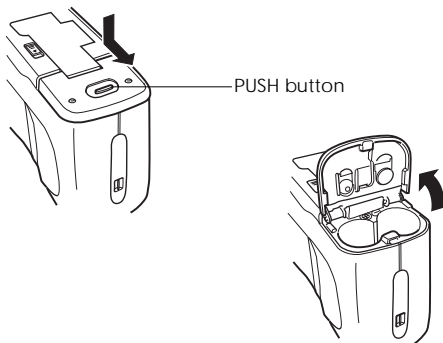

2. Insert both batteries into the compartment, positioning the + and - ends as shown below. Then lower the battery cover.

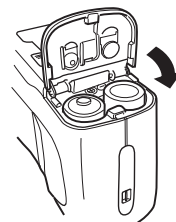

3. Hold the battery cover down and slide it to the left as shown in the illustration.

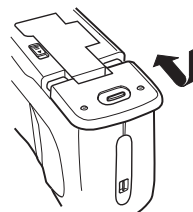

When the battery power is almost out, a low battery icon  appears on the display panel. When the battery power runs out, this icon flashes and the camera automatically turns off. Remove and recharge your batteries, then install the batteries.

Replacing the batteries

Replace your PhotoPC 800 batteries when the low battery icon  appears on the camera's display panel. Be sure to replace both batteries at the same time. You can replace them with the included rechargeable AA Ni-MH batteries.

Note:

- ❑ *If you use rechargeable Ni-MH batteries in the PhotoPC 800, replace them with two fully-charged batteries. If you find that your batteries run out soon after recharging them a number of times, make sure you discharge them completely before recharging.*
- ❑ *The Ni-MH rechargeable batteries are available as an option.*

Handling the batteries

Keep the battery ends clean by wiping them with a dry cloth.



Warning:

- ❑ *Do not apply heat or force to batteries, and do not disassemble, drop, short-circuit, or put batteries into fire or water.*
- ❑ *Do not keep batteries loose in your pockets.*
- ❑ *Do not mix different types of batteries; this can cause fire or explosion.*
- ❑ *Always use batteries from the same package as a set. Do not mix old and new batteries.*

Storing the batteries

If you do not plan to use the camera for a long period of time, remove the batteries and store them at a low temperature in a dry location.



Warning:

- ❑ Do not store batteries with metal objects, which could short-circuit the batteries.
- ❑ Avoid storing batteries in extremely hot or humid locations.
- ❑ Store batteries out of reach of children.
- ❑ Always remove the batteries from the camera and charger before storing. Batteries left in your camera and charger for a long time may leak and cause damage.

Disposing of the batteries

Before disposing of batteries, make sure you discharge them completely.



Warning:

- ❑ Be sure to securely cover the + end of each battery with tape to prevent combustion or explosion when disposing.
- ❑ Dispose of used batteries according to the manufacturer's instructions and in compliance with all applicable laws. Contact your local government agency for information about battery recycling and disposal.

For the Netherlands users:

Do not dispose of the batteries with ordinary refuse. Instead, dispose of them as small chemical waste in accordance with local laws, and the following Dutch Government Gazette 45, KCA Marking:



Bij dit produkt zijn batterijen geleverd. Wanneer deze leeg zijn, moet u ze niet weggooien maar inleveren als KCA.

For German users:

Do not dispose of batteries with ordinary refuse. Instead, dispose of them in a recycle box in accordance with local laws.

Setting Up Your Camera

This section explains how to attach the hand strap to your camera, install a memory card, and make a few basic camera settings.

Attaching the hand strap to your camera

Before attaching the hand strap, be sure to read the safety instructions in “When using the hand strap” on page 4.

To attach the hand strap, loop the strap around the holder on the side of the camera as shown below.

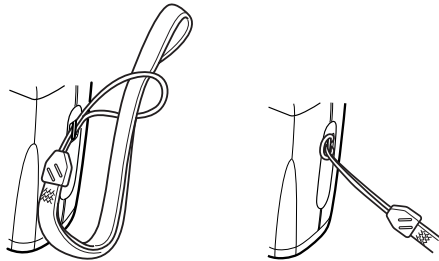

Installing and removing a CompactFlash Card

1

You need to install a CompactFlash Card in your camera before you can take any photos. Follow these steps.

1. Make sure the camera's dial switch is turned to Off.
2. Turn the camera upside down and open the memory card cover by sliding the memory card cover lock in the direction of the arrow.

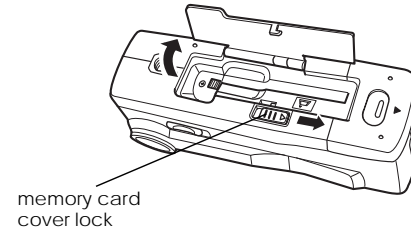

3. Insert the card all the way into the memory card slot. Make sure the front of the card and the front of the camera are facing the same way as shown.

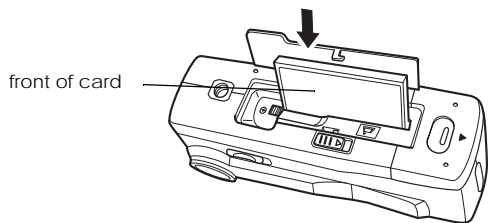

To remove the card, press the eject button next to the memory card, then remove the card by hand.

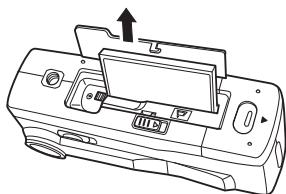
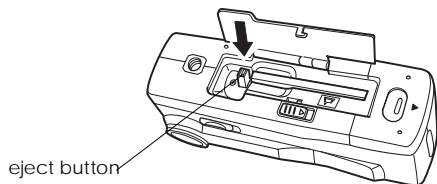

Caution:

- ❑ Never remove the card while the camera is on. Data in the card may be lost or damaged.
- ❑ Avoid using or storing the card in direct sunlight, or in places that are extremely hot, humid, or dusty.

4. Close the cover.

Setting the language

For PAL model cameras, you need to set the language for messages displayed on the LCD monitor the first time you use it. Depending on the country of purchase, you can choose English, Japanese, French, German, Italian, Portuguese, Spanish or Chinese.

Follow these steps to set the language.

1. Turn the camera's dial switch to . A message stating that you need to set the language appears on the LCD screen.
2. Press the ISO or W.B. button to move the cursor to the language you want.
3. Press the MENU button to save your selection.

To change the language setting, see “Selecting the language” on page 2-28.

Next, set the date and time as described in the following section.

Setting the date and time

When you install the batteries for the first time, you need to set the date (year, month, and day) and time (hour and minutes). After you make these settings, the camera automatically records the date and time of each picture.

Follow these steps to set the clock on the LCD monitor.

Note:

If you connect the PhotoPC 800 to your computer and access EPSON Photo!3 when the camera's clock is not set, the camera's date and time is set to that of the computer's automatically. For instructions on connecting the camera to the computer and accessing EPSON Photo!3, see the EPSON Photo!3 User's Guide.

1. Turn the camera's dial switch to . A screen appears with the setting for the month highlighted in red.

Note:

If you do not want to set the clock, press the MENU button to exit the menu.

2. Press the + or - button to increase or decrease the number, until the month is correct.
3. Press the ISO or W.B. button to move through each item, and make adjustments as described in the previous step.
4. When the day, year, hour, and minute settings are correctly adjusted, press the MENU button.

You are now ready to take pictures with your PhotoPC 800. Turn to Chapter 2, “Taking Pictures” for simple, step-by-step instructions.

After taking photos, you can transfer the images to your computer in the following ways:

- Using your camera along with EPSON Photo!3 software. For software installation instructions, see the *EPSON Photo!3 User's Guide*.
- Using the Direct Print to print photos. For more information see Chapter 4, “Using Direct Print to Print Photos”.

- By inserting your card into your computer's memory card slot directly or PCMCIA adapter. To use the PCMCIA adapter with your CompactFlash Card, see "Installing a CompactFlash Card into your computer" on page 5-2.

Using the PhotoPC 800 to take pictures is similar to using a traditional “point and shoot” camera. This chapter explains how to take photos with the camera and covers the following topics.

Picture-taking range

Checking the display panel

Basic settings

Taking different kinds of pictures

Using the advanced settings

Getting tips from the online *Color Guide*

Getting Ready

This section helps you prepare to take pictures with your PhotoPC 800. It includes information on your camera’s picture-taking range and explains how to make image quality and flash control settings.

Note:

EPSON is not responsible for any images you may lose while using our products and software. Make sure your camera works normally before taking important pictures.

Your camera’s picture-taking range

The camera should be at least 50 centimeters away from the subject when composing a shot through the viewfinder.

Close-up photos can be taken from as close as 15 to 50 centimeters to the subject using the macro feature. For instructions on using this feature, see “Using the macro setting to take close-ups” on page 2-12.

The flash has an effective range of 50 to 340 centimeters, or 15 to 50 centimeters when using the macro function (the range varies depending on the sensitivity setting). See “Setting the flash” on page 2-8 for more details.

When you are taking pictures outdoors, make sure the sun is behind you. In very bright light (for example, at the beach or in snow) your pictures may come out too light. However, you can adjust the exposure manually to make your photos brighter or darker. For instructions, see “Making advanced exposure adjustments” on page 2-17. You can also correct these problems with your computer using image editing software.

Checking the display panel



The large number in the lower right of the display panel shows the remaining amount of pictures you can take.

This number is effected by the image quality setting. When you adjust the image quality, the number of remaining pictures changes accordingly.

To find out how many photos you have taken, set the camera’s dial switch to . The LCD monitor displays the picture number/total number of pictures taken on the right side of each picture.

Note:

If there are any audio recordings stored on your memory card, the number on the display panel may be greater than the actual number of remaining pictures.

When the memory card is full, the number on the display panel reads 0, the status light on the back of the camera flashes red, and you are unable to use the shutter button. Before you can take any more pictures, you need to erase some or all of the images in the memory card. See “Erasing photos” on page 3-5 for instructions. If you want to save your photos before you erase them, connect the camera to your computer and transfer the photos as described in the *EPSON Photo!3 User’s Guide*.



When using the quick shooting feature, the number of photos taken and temporarily saved in the camera is displayed in brackets.

8.0 30

In the Program and Manual camera modes, while holding the shutter button down halfway, the exposure value appears on the left and the shutter speed appears on the right.

SEt

When you turn the camera's dial switch to **1**, SEt is displayed on the display panel.

rEc

While making an audio recording, rEc appears on the display panel.

Int

When taking photos with the time lapse feature, Int appears on the display panel.

Using the dial switch

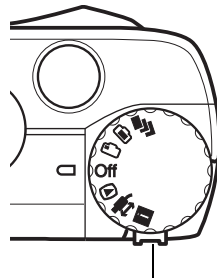



dial switch lock

You can turn the camera on by turning its dial switch to one of six different positions. This section gives an overview of when to use each dial position.

Note:
To turn the dial switch when the camera is off, you must hold in the dial switch lock.



Dial positions for taking pictures

When you want to take pictures, turn the dial switch to one of the orange icons on the top of the dial.

-  For taking multiple exposures. See “Taking Multiple Exposures” on page 2-20 for details.
-  For taking photos with the LCD monitor. See “Taking Pictures Using the LCD monitor” on page 2-10 for details.
-  For taking pictures with the viewfinder. See “Taking Pictures Using the Viewfinder” on page 2-4 for details.

Other dial positions

To perform other camera operations, turn the dial switch to any of the bottom icons.

-  For playing back and managing photos. See Chapter 3, “Viewing and Managing Your Photos” for details.
-  For using Direct Print, EPSON Photo!3, and other software. See Chapter 4, “Using Direct Print to Print Photos” and the *EPSON Photo!3 User’s Guide* for details.
-  For viewing information and setting up the camera. See “Making Additional Settings” on page 2-24 for details.

Making basic settings

The three small buttons on top of the camera allow you to easily make a few basic settings. You can make these settings when the camera’s dial switch is set to one of the orange icons.

- ★ Changes the image quality setting. See “Adjusting the image quality” on page 2-7 for details.



Changes the flash setting. See “Setting the flash” on page 2-8 for details.



Turns the self timer on and off. See “Using the self timer” on page 2-6 for details.

Note:

Using EPSON Photo!3, you can also take photos and make basic settings from a computer to which the PhotoPC 800 is properly connected. See the EPSON Photo!3 User’s Guide for more details.

Taking Pictures Using the Viewfinder

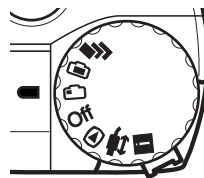

Using the viewfinder instead of the LCD monitor when taking pictures helps save battery power, and can make it easier for you to hold the camera steady when pressing the shutter button.

Follow the steps below.

1. Open the lens cover and turn the camera’s dial switch to . Then wait until the shooting light beside the viewfinder turns green.

- Look straight through the viewfinder and center your subject in the cross-hairs.

Note:

- ❑ *Make sure you are not blocking the lens with your finger, strap, clothing, or other object.*
- ❑ *The frame in the viewfinder indicates the area captured when taking pictures at close range.*

- Hold the shutter button halfway down to lock the auto focus. The shooting light beside the viewfinder stops blinking after the lens locks in focus. If you wish, you can now move your subject off-center without altering the focus.



- Press the shutter button the rest of the way down to take the photo.



- Hold the camera still until the status light above the LCD monitor comes back on, or until the camera beeps. Then release the shutter button.

You can take another photo when the shooting light next to the viewfinder stops blinking.

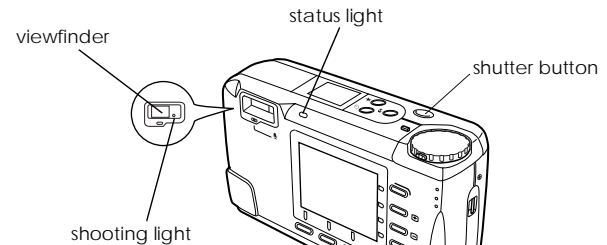



After you take a picture, the status light blinks. This indicates that the image is captured and the camera is processing it. When the light stops flashing, the image is saved. Saved images remain in the memory card even when the camera is turned off, the batteries are removed, or the memory card is removed from the camera.

Using the self timer



Turning on the self timer creates a 10-second delay between the time you press the shutter button and the moment the actual image is captured, allowing you to take pictures of yourself. The timer icon appears on the display panel when you turn on the timer. Follow the steps below.

1. Secure the camera on a flat surface or a tripod.
2. Open the lens cover.
3. Turn the camera's dial switch to . Then wait until the status light beside the viewfinder turns green.
4. Press the  timer button on the top of the camera. The timer icon appears on the display panel.
5. Press the shutter button. The timer icon and the red timer light on the front of the camera flash slowly for eight seconds, then rapidly for two seconds before the shutter releases.

To take another picture using the self timer, you need to press the  timer button again.

Note:

- ❑ *To stop taking a picture after pressing the shutter button, press the shutter button again, or press the  timer button.*
- ❑ *You can also use the self timer with the continuous shooting feature. The camera takes up to ten pictures in sequence, ten seconds after you press the shutter button. To turn continuous shooting on, see “Using the continuous shooting feature” on page 2-20.*

Making Settings in the Viewfinder Dial Position

You can use camera buttons to make a variety of settings when taking pictures with the viewfinder. This section explains how to make these settings.

Adjusting the image quality

The PhotoPC 800 has four image quality settings. Press the image **★** quality button on the camera to cycle from one setting to another. You can see the currently selected image quality setting on the display panel or LCD monitor. You can always switch freely between these settings and mix pictures of varying quality in the camera. The memory card's image capacity will vary accordingly.

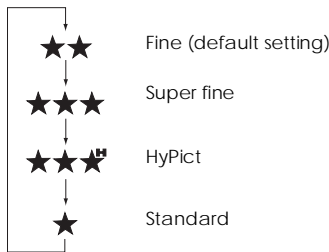

★ Standard
Images are captured at 640 × 480 pixels. The camera holds approximately 120 pictures without audio recordings in attached 8 MB Compact Flash memory card, and the images are less detailed.

★ ★ Fine
Images are captured in color at 1600 × 1200 pixels. These pictures have moderate detail, and approximately 24 pictures can be stored in the included 8 MB CompactFlash Card.

★ ★ ★ Super fine
Images are captured in color at 1600 x 1200 pixels. These pictures have great detail, and approximately 12 pictures can be stored in the included 8 MB CompactFlash Card.

★ ★ ★ H HyPict
Images are captured in color at 1984 × 1488 pixels. These pictures have the greatest detail, and approximately ten pictures can be stored in the included 8 MB CompactFlash Card.

Note:

- ❑ *After you take a picture using the HyPict setting, the camera takes approximately 12 seconds to process an image to the memory card.*
- ❑ *HyPict is not available when using the continuous shooting features.*
- ❑ *When using the HyPict image quality setting, you cannot use the quick shooting feature or make audio recordings.*
- ❑ *The Standard image quality setting is not available when taking panoramas.*
- ❑ *When the camera is turned off, the image quality setting does not change.*
- ❑ *The number of pictures you can take varies depending on the complexity of the photo you take, and the amount of audio recording files saved in the memory card.*

Setting the flash

The built-in flash is effective within a range of 50 to 340 centimeters, or 15 to 50 centimeters when using the macro feature. This range varies depending on the sensitivity setting (see page A-3 for details). Turn on the camera and press the flash  button on the camera to cycle through the three flash settings. The settings appear on the display panel as shown below.

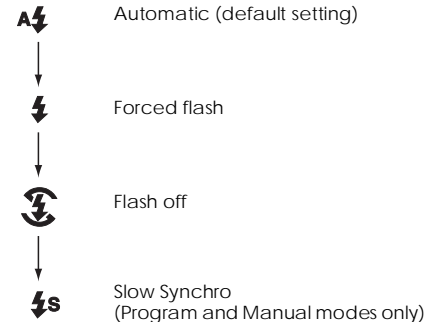

Automatic

The flash fires automatically whenever more lighting is needed.



Forced flash

The flash fires with every picture you take. Use this setting to compensate for backlighting; for example, when you are facing the sun.



Flash off

The flash is disabled, even when adequate lighting is not available. Use this setting for special effects, or when flash photography is prohibited.



Slow Synchro

The camera's shutter speed slows to enhance the clarity of background details in the shot with object when taking pictures at dawn or twilight, or in places with an illuminated background.

Note:

- ❑ *After turning on the camera and taking a flash photo, the flash icon blinks until the flash is fully recharged.*
- ❑ *Slow Synchro is only available in the Program or Manual camera modes. To change the camera mode, see “Making the camera mode setting” on page 2-24.*
- ❑ *When using the quick shooting function, Slow Synchro is disabled.*

Adjusting the sensitivity setting

When taking pictures with the viewfinder, you can use the camera's ISO button to change the sensitivity setting. The arrow icons in the display panel next to the ISO mark change accordingly.

Note:

You cannot change settings as described above when in the Full Auto camera mode. To change the camera mode, see “Making the camera mode setting” on page 2-24.

For details on making sensitivity adjustments, see “Adjusting the sensitivity setting” on page 2-15.

Adjusting the white balance setting

When taking pictures with the viewfinder, you can use the camera's W.B. button to change the white balance setting. The setting appears in the display panel next to the W.B. mark.

Note:

You cannot change settings as described above when in the Full Auto camera mode. To change the camera mode, see “Making the camera mode setting” on page 2-24.

For details on making white balance adjustments, see “Adjusting the white balance setting” on page 2-14.

Adjusting the exposure setting

When taking pictures with the viewfinder, you can use the camera's + or - button to change the exposure setting. The setting appears in the display panel next to the +/- mark.

Note:

You cannot change the settings described above when in the Full Auto camera mode. To change the camera mode, see "Making the camera mode setting" on page 2-24.

For details on making exposure adjustments, see "Making basic exposure adjustments" on page 2-16, and "Making advanced exposure adjustments" on page 2-17.

Taking Pictures Using the LCD monitor

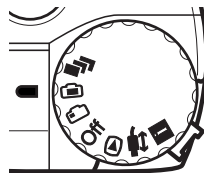

Using the LCD monitor allows you to verify the whole image before shooting, and confirm the image right after shooting. When you want to take pictures using the panorama or digital zoom features, or when taking close-ups, use the LCD monitor.

Note:

You can also make audio recordings when taking pictures with the LCD monitor. See "Making Audio Recordings for Photos" on page 2-22.

Follow these steps to take pictures using the LCD monitor.

1. Open the lens cover and turn the camera's dial switch to . You will see a live preview on the LCD monitor. Center your subject on the screen.

Note:

Make sure you are not blocking the lens with your finger, strap, clothing, or other object.

2. Hold the shutter button halfway down to lock the auto focus. A small green circle ● appears on the upper right corner of the monitor. If you wish, you can now move your subject off-center without altering the focus.

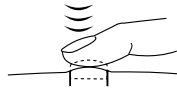

3. Press the shutter button the rest of the way down to take the photo.





4. Hold the camera still until the status light above the LCD monitor comes back on, or until the camera beeps. Then release the shutter button.

When you press the shutter button, the monitor freezes and displays the picture until the camera finishes processing it. You can delete the image while it is being displayed on the monitor by pressing the bottom button at the right side of the monitor (Delete appears next to this button). After the status light turns green, you can take another photo.

Using the digital zoom feature

Your PhotoPC 800's digital zoom feature allows you to double the size of your images. Follow the steps below.

1. Open the lens cover and turn the camera's dial switch to .
2. Press the button next to the ×1 that appears on the LCD monitor. A yellow frame appears around the previewed image and DIGITAL ZOOM appears briefly in the center of the monitor.

If you want to use the digital zoom and continuous shooting features together, turn the dial switch to .

3. Frame your subject in the LCD monitor and press the shutter button.

Using the macro setting to take close-ups



For best results when taking pictures of objects 15 to 50 centimeters away from the camera, use the macro feature. Follow the steps below.

1. Open the lens cover and turn the camera's dial switch to
2. Press the button next to the words Normal Frame that appear on the monitor. A green frame appears around the previewed image and MACRO appears briefly in the center of the monitor.

If you want to use the continuous shooting and macro features together, turn the dial switch to

3. Frame your subject in the LCD monitor and press the shutter button.

Taking panoramas



You can take panoramas using the LCD monitor. Follow the steps below.

1. Open the lens cover and turn the camera's dial switch to
2. Normal Frame appears on the bottom right of the LCD monitor. Press the button next to Normal Frame two times. A black frame appears above and below the previewed image, and PANORAMA appears briefly in the center of the monitor.

If you want to use the continuous shooting feature while taking panoramas, turn the dial switch to

3. Frame your subject in the LCD monitor and press the shutter button.

Note:

- ❑ You cannot select Standard image quality when taking panoramas. For an explanation of image quality settings, see “Adjusting the image quality” on page 2-7.

- ❑ *With the PhotoPC 800, the file size of a panorama photo is smaller than the file size of any other photo of the same image quality.*

Making Settings in the LCD Monitor Dial Position

This section covers the various settings you can make when using your camera in the LCD monitor dial position. The settings range from basic to advanced, and the availability of these settings change according to the current camera mode setting. To change the camera mode setting, see “Making the camera mode setting” on page 2-24.

Making a predefined exposure setting

The PhotoPC 800 has four predefined exposure settings that are accessible when in the Program camera mode.

When to use a predefined exposure setting

Normal

For taking basic photographs. Uses the following settings:

- ❑ Auto exposure
- ❑ Divided brightness metering system

Sports

For photographing quickly moving subjects. Uses the following settings:

- ❑ High shutter speed
- ❑ Automatic sensitivity
- ❑ Divided brightness metering system

Portrait

For photographing portraits. Uses the following settings:

- ❑ Aperture fixed at f2.4
- ❑ Spot metering system

Landscape

For photographing landscapes or scenery. Uses the following settings:

- ❑ Aperture set to f8.0, changes automatically to f2.4 when subject is dim
- ❑ Divided brightness metering system

How to change the predefined exposure setting

1. Make sure Program camera mode is selected. (See “Making the camera mode setting” on page 2-24.)
2. Open the lens cover, then turn the camera’s dial switch to .
3. Hold down the MENU button until the next screen appears.
4. Press the ISO button to select Normal, Sport, Portrait, or Landscape, then press the MENU button to save your setting.

Adjusting the white balance setting

The PhotoPC 800 has three white balance settings that are accessible when in the Program or Manual camera mode.

When to adjust the white balance

Your camera’s white balance default setting is AUTO, which means white balance is adjusted for your photos automatically. At certain times you may want to adjust the white balance setting so that the colors in your images appear more like those seen by the eye.

When taking pictures at dusk, for example, set white balance to FIX to increase reddish color tones in your images. When taking pictures under white light, however, keep white balance set to AUTO to avoid a green tone in your images. Use CUSTOM to make user settings. See “Making user settings for white balance” on page 2-28.

How to adjust the white balance

Follow the steps bellow to adjust the white balance.

1. Make sure you are using the Program or Manual camera mode. (See “Making the camera mode setting” on page 2-24.)
2. Open the lens cover and turn the camera’s dial switch to .
3. In the Program camera mode, press the W.B. button to select AUTO, FIX or CUSTOM.

In the Manual camera mode, hold down the MENU button until the next screen appears. Press the W.B. button to select AUTO, FIX or CUSTOM, then press the MENU button to save your setting.



Note:

- You can see the value for the white balance setting on the display panel.

- ❑ *You can also make white balance settings when taking pictures with viewfinder by pressing the W.B. button.*

Adjusting the sensitivity setting

Your PhotoPC 800 has the following sensitivity settings:

-  Standard sensitivity, equivalent to ISO 100
-  High sensitivity, equivalent to ISO 200
-  Super high sensitivity, equivalent to ISO 400

When to adjust the sensitivity

Set the sensitivity to high or super high when taking photos:

- ❑ Of fast moving subjects (useful for in-door sports)
- ❑ Of distance subjects with a flash
- ❑ In the dark without a flash (useful when flash photography is prohibited)

EPSON recommends setting sensitivity to standard  at all other times, as image quality is lower when you use higher sensitivity settings.

How to adjust the sensitivity

Follow the steps below to change the sensitivity.

1. Make sure you are using the Program or Manual camera mode. (See “Making the camera mode setting” on page 2-24.)
2. Open the lens cover and turn the camera’s dial switch to .
3. In the Program camera mode, press the ISO button to select standard, high or super high sensitivity.

In the Manual camera mode, hold down the MENU button until the next screen appears. Then press the ISO button to select standard, high or super high sensitivity.

Note:

- ❑ *You can see the value for the sensitivity setting on the display panel.*
- ❑ *You can also make the sensitivity setting when taking pictures with viewfinder by pressing the ISO button.*

Making basic exposure adjustments



Exposure refers to the amount of light the camera captures when a photo is taken.

The camera's default exposure setting is AUTO, meaning the exposure is adjusted automatically. However, you can manually adjust the exposure to change the darkness or brightness of your photos for certain conditions.

When to adjust the exposure

Increase the exposure setting when:

- You want to make your photos lighter.
- The photo you have taken is too dark, and you want to increase the brightness.
- You are taking pictures of a white object which may tend to look grayish in the photos.
- You are taking pictures of an object with a bright background, such as a chair in front of a sunlit window.
- You are taking photos at the beach or in the snow on sunny days, or taking photos of an object with a white background.

Reduce the exposure setting when:

- You want to make your photos darker.
- The photo you have taken is too bright, and you want to increase the darkness.
- You are taking pictures of a black object which may tend to look grayish in the photos.
- You are taking pictures of an object with a black background.

How to adjust the exposure

Follow the steps below to change the exposure setting.

1. Make sure you are using the Program or Manual camera mode. (See "Making the camera mode setting" on page 2-24.)
2. Open the lens cover, then turn the camera's dial switch to .
3. In the Program camera mode, press the + button to raise the exposure value, or the - button to lower the exposure value. You can make nine different settings in increments of 0.5, from -2.0 to 2.0 EV.

In the Manual camera mode, press the ISO button to select AUTO, then press the + button to raise the exposure value, or the - button to lower the exposure value. You can make 21 different settings in increments of 0.2, from -2.0 to 2.0 EV.

Note:

- ❑ *You can see the value for the exposure setting on the display panel.*
- ❑ *You can set the exposure settings when taking pictures with the viewfinder and you set Program or Manual mode in Setup position. Use the + button to go up the value or - button to go down the value of the exposure.*
- ❑ *Photographic experience and knowledge is necessary to correctly adjust exposure. Be sure to make proper exposure settings when taking important photos.*
- ❑ *When shooting under poor photographic conditions, EPSON recommends taking several photos of the same object using different exposures.*

Making advanced exposure adjustments

When in the Manual camera mode, you can set the exposure manually by changing the shutter speed and aperture.

Note:

- ❑ *Photographic experience and knowledge is necessary to correctly adjust shutter speed and aperture. Be sure to make appropriate settings when taking important photos.*
- ❑ *The advanced exposure setting does not change when the camera is turned off.*

Setting the shutter speed

You can select shutter speeds from 1/2 to 1/750. Follow these steps to change the shutter speed.

1. Make sure you are using the Manual camera mode. (See “Making the camera mode setting” on page 2-24.)
2. Open the lens cover, then turn the camera's dial switch to .

3. Press the ISO button to change the exposure setting to MANUAL. Then press the + button to increase the shutter speed, or press the - button to reduce the shutter speed.

Setting the aperture

You can select an aperture setting of f2.4 or f8. Follow the steps below.

1. Make sure you are using the Manual camera mode. (See “Making the camera mode setting” on page 2-24.)
2. Open the lens cover and turn the camera’s dial switch to .
3. Press the ISO button to select Exposure MANUAL. Then press the W.B. button to select either F2.4 or F8.

Making manual focus settings



When in the Manual camera mode, you can make focus settings manually. Follow these steps.

1. Make sure you are using the Manual camera mode. (See “Making the camera mode setting” on page 2-24.)

2. Open the lens cover, then turn the camera’s dial switch to .

If you want to make focus settings manually when using the macro feature or taking panoramas, press the button next to Normal Frame until MACRO or PANORAMA appears in the center of the screen.

3. Hold down the MENU button until the screen changes.
4. Press the + or - button to select a manual focus setting.

When using the normal or panorama frame, you can select AF for auto focus,  (when the subject is about one meter away),  (when the subject is about three meters away), or  (when the subject is more than three meters away).

When using the macro feature, you can make settings from 1 (when the subject is about 0.15 meters away) to 10 (when the subject is about 0.5 meters away) or AF for auto focus. The smaller the value, the closer the focus becomes.

Changing the metering system

Your camera is set to the divided brightness metering system by default. When in the Manual camera mode, you can change freely between the divided brightness and spot metering systems.

Note:

When taking photos with the Portrait exposure setting, the camera automatically uses the spot metering system. To select the Portrait exposure setting, see “Making a predefined exposure setting” on page 2-13.

When to change the metering system

Use the spot metering system for most photographic situations.

Use the divided brightness metering system when:

- ❑ Taking pictures of objects that have a bright background, such as a chair in front of a sun-lit window
- ❑ There is a clear contrast in shading between the upper and lower part of the frame

How to change the metering system

Follow the steps below to change the metering system.

1. Make sure you are using the Manual camera mode. (See “Making the camera mode setting” on page 2-24.)
2. Open the lens cover, then turn the camera’s dial switch to .
3. Hold down the MENU button until the next screen appears. To change the metering system, press the button next to the word Metering that appears on LCD monitor.



When the divided brightness metering system is selected, a square icon with nine squares appears in the lower right corner of the screen.



When the spot metering system is selected, a square icon with a small circle appears in the lower right corner of the screen.

Taking Multiple Exposures

To use the continuous shooting or time lapse shooting feature, turn the camera's dial switch to .

Using the continuous shooting feature

This shooting feature is useful when you want to break down a complex motion into a series of easy-to-see steps. It is also useful to take several pictures, then choose from those the ones you like best. When the image quality is set to Standard or Fine, you can take close to two photos per second, up to ten photos. When you select Super Fine, you can take one photo per second, up to five or six photos.



Note:

- When using continuous shooting, you cannot use the flash or select the HyPict image quality setting.
- You can only make an audio recording for the last photo when using the continuous shooting feature.

Follow these steps to take pictures using the continuous shooting feature.

1. Open the lens cover.



Note:

The settings you can make using the dial switch to  remain when you use the continuous shooting feature. Turn the dial switch to  and make the appropriate settings.

2. Turn the camera's dial switch to . A red frame appears around the previewed image, and CONTINUOUS appears briefly on the LCD monitor.

You can adjust the image quality and use the self timer with the buttons on the top of the camera. The self timer creates a ten second delay between the time you press the shutter button and the moment the actual image is captured.

Note:

- When using continuous shooting, you cannot use the flash or select the HyPict image quality setting.
- If you need to make more settings, turn the camera's dial switch to . After you finish making settings, turn the dial switch back to  and go to the next step.

3. Press the shutter button and hold it down to begin taking a series of photos.
4. Release the button to stop taking pictures.

Using the time lapse feature



This feature allows your camera to automatically take pictures at a preset time interval. Use this feature creatively to capture scenes that change over time, such as sunsets, plant life, or a busy street corner. You can set the time interval from ten seconds to 24 hours.

Note:

When using the audio recording, the shortest time interval available is 20 seconds instead of ten.

1. Open the lens cover.

Note:

The settings you can make using the dial switch to  remain when you use the continuous shooting feature. Turn the dial switch to  and make the appropriate settings.

2. Turn the camera's dial switch to . A red frame appears around the previewed image and CONTINUOUS appears at the top of the LCD monitor.

3. Hold down the MENU button until the screen changes and INTERVAL appears on the LCD monitor.
4. The hours, minutes, and seconds appear in the center of the screen, with seconds highlighted. Press the + and - buttons to change the value of the highlighted time unit. To move highlight a different time unit, press the ISO and W.B. buttons.

You can choose an interval of 24 hours by pressing the button next to Max Interval.

You can choose the shortest available interval, ten or 20 seconds, by pressing the button next to Min Interval.

5. Once you have set the desired time, begin taking photos by pressing the shutter button.

Note:

- The camera may automatically turn off after you take the first picture; it automatically turns back on to take pictures at the set time.*
- When using the self timer feature, the camera takes a photo ten seconds after you press the shutter button, then continues taking photos at the set time lapse interval.*

6. To stop taking photos, turn the camera's dial switch to Off.

Making Audio Recordings for Photos

Your PhotoPC 800 has a built-in microphone for recording messages to attach to your photos. You can make three, five or ten second audio recordings just after shooting photos with the LCD monitor. You can also make recordings for previously taken photos.

Note:

- ❑ *You cannot replay audio recordings with your camera. To replay audio recordings, use the included EPSON Photo!3 software with your computer. See the EPSON Photo!3 User's Guide for instructions.*
- ❑ *To erase audio recordings, see "Erasing audio recordings" on page 3-8.*

Right after taking photos

To make audio recordings just after taking photographs, you need to first make a few settings. Follow these steps.

Note:

- ❑ *You cannot make audio recordings when taking photos with the viewfinder.*
- ❑ *When using the quick shooting feature, or when the HyPict image quality setting is selected, you cannot make audio recordings.*

1. Turn the camera's dial switch to **1**.
2. Press the MENU button. Rec appears on the bottom of the LCD monitor, and the current audio recording setting appears below Rec.
3. Press the ISO button to choose a different audio recording setting. You can choose between three, five or ten second recordings.

Note:

If you do not want to make audio recordings after taking pictures, choose OFF.

4. To make recordings when taking pictures with the LCD monitor, turn the dial switch to **1**.

Note:

- ❑ *To make recordings when using the continuous shooting or time lapse feature, turn the dial switch to . See “Using the continuous shooting feature” on page 2-20, or “Using the time lapse feature” on page 2-21.*
 - ❑ *You cannot make recordings when taking pictures using the viewfinder.*
5. Frame your subject in the LCD monitor and press the shutter button.
 6. The captured image appears on the screen momentarily, then the camera begins the audio recording. A countdown of the recording time appears on the screen. You can record a message until the time runs out by speaking into the built-in microphone at the back of the camera.

3. You can make three, five, or ten second recordings. Press the button next to the desired time.

If there is already a message on the current photo, a confirmation message appears. To erase the old recording and make a new one, press the button next to Yes. Press the button next to No to cancel.

4. A countdown of the recording time appears on the screen. You can record a message until the time runs out by speaking into the built-in microphone at the back of the camera.

For existing photos

To make recordings for previously taken photos, follow these steps.

1. Turn the dial switch to .
2. Hold down the MENU button until the screen changes. Then press the button next to RECORD.

Making Additional Settings

When the camera's dial is in the **1** position, you can change certain camera settings, including the internal clock, the beep, the LCD monitor's brightness level, and the automatic shut-off time. You can also set the display language.

Setting the time and date

1. Turn the dial switch to **1**.
2. The date (year, month, day) and the time (hour and minutes) appear on the upper right of the LCD monitor. Press the button next to the date and time.
3. To adjust the value of the highlighted item, use the + and - buttons. To change which item is highlighted, use ISO and MENU buttons.
4. After setting the correct time and date, save the settings by pressing the MENU button.

Note:

- You will have to reset the time if the camera is unplugged and the batteries are removed for more than 30 minutes.

- You can also set the time and date with your computer. See the EPSON Photo!3 User's Guide for details.

Making the camera mode setting

The PhotoPC 800 has three camera modes to fit your photographic needs. Each mode gives you a different amount of control over the camera settings, whether taking photos with the viewfinder or LCD monitor. Read this section to choose the appropriate mode, and to change the mode if necessary.

Choosing a camera mode

Full Auto camera mode

Allows you to take basic photos without having to make complex settings. Available settings include:

- Flash, including auto, forced, and off
- Self timer
- Image quality
- Digital zoom
- Macro, Panorama or Normal frame

Program camera mode

For users who want a moderate amount of control over the camera's functions. Available settings include:

- All settings available in Full Auto camera mode
- Slow Sync flash
- Sensitivity
- Predefined exposure
- Basic or custom white balance

Manual camera mode

For experienced users who want complete control over the camera's wide array of settings and features. Available settings include:

- All settings available in Program camera mode, except predefined exposure
- Fine exposure adjustments, or shutter speed and aperture settings
- Manual focus features
- Spot and divided brightness metering systems

Changing the camera mode

To change the camera mode setting, follow these steps.

1. Turn the camera's dial switch to **1**. The current camera mode setting appears on the LCD monitor next to the + button.
2. Press the + button to select the appropriate mode.

Changing the color/monochrome setting

You can take both color and monochrome photos with the PhotoPC 800. To select change between color and monochrome, follow these steps.

Note:

The file size of photos is the same for color and monochrome.

1. Turn the dial switch to **1**. The current setting appears on the LCD monitor next to the - button.
2. Press the - button to change the setting.

Quick shooting feature

After taking a picture, the PhotoPC 800 takes few seconds to process and save the image in the installed memory card. During this time you cannot take a photo, which means that you must wait a few seconds before taking a second photo. The quick shooting feature allows you to take up to ten pictures without a delay by temporarily saving all the images in the camera, then later saving them to the memory card.

Note:

When using the Super Fine image setting, you can only take up to five or six photos without a delay.

To turn on the quick shooting feature, follow these steps.

1. Turn the camera's dial switch to **1**. Normal Shot appears in the bottom right of the LCD monitor.
2. Press the button next to Normal Shot to turn on the quick shooting function. The image quality mark on the display panel flashes, indicating that the quick shooting function is on.

Note:

- ❑ *When the image quality is set to HyPict, the quick shooting function is disabled.*

- ❑ *You cannot make audio recordings when using the quick shooting feature.*
- ❑ *When battery power or CompactFlash Card memory is low, you cannot use the quick shooting feature.*
- ❑ *When using the quick shooting feature, bracketed numbers on the display panel indicate the number of the pictures saved temporarily in the camera.*

Setting the automatic shut-off feature

When using this feature, your camera saves battery power by automatically turning off when idle for a designated period of time. You can have the camera turn off after ten seconds, 30 seconds, one minute, or three minutes. This feature is only effective when using batteries to power the camera.

Note:

When the camera is connected to a computer with a serial cable, the power automatically turns off when the camera is idle for five minutes.

Changing the setting

To change this feature's setting, follow these steps.

1. Turn the camera's dial switch to **1**.
2. Press the MENU button. The current setting appears in the upper right of the LCD monitor.
3. To change the setting, press the button next to the current setting.

Turning the camera back on

When the dial switch is set to an orange icon, you can turn the camera back on by pressing the shutter button, or turning the dial switch off, then on again.

When the dial switch is set to **1** or **2**, you can turn the camera back on by pressing any button on the back of the camera, or by turning the dial switch off, then on again.

Setting the LCD monitor's brightness

Follow the steps below to change the LCD monitor's brightness level.

1. Turn the dial switch to **1**.
2. Press the MENU button.
3. Press the + or - button to increase or decrease the brightness level.

Setting the beep

You can have the camera beep whenever you press any of its buttons, only when you use the shutter button, or never. Follow these steps to change the beep setting.

1. Turn the dial switch to **1**.
2. Press the MENU button. Then press the W.B. button to select Always, Shutter or Never.

Making user settings for white balance

Following the steps below to create your own white balance setting.

Note:

The custom white balance setting does not change even when the camera is turned off.

1. Open the lens cover.
2. Turn the camera's dial switch to **1**.
3. Press the MENU button.
4. Press the button next to New W/B at the bottom right of the LCD monitor. A message appears asking you if you want to save the new settings. Press the button next to Yes to continue making settings.
5. Place a white sheet in front of the camera lens so that it is previewed on the whole LCD monitor.

You can also use a colored sheet. For example, to create a sepia hue, use a blue sheet. To create a blue hue, use a yellow sheet. Experiment with other colors for different effects.

Note:

To cancel the white balance setting, press the MENU button.

6. Press the shutter button to make the new setting.

To use your custom white balance setting, see "Adjusting the white balance setting" on page 2-14.

Selecting the language



Depending on the country of purchase, you can choose English, Japanese, French, German, Italian, Portuguese, Spanish or Chinese as the language used to display camera information on the LCD monitor. To select the language, follow the steps below.

1. Turn the camera's dial switch to **1**.
2. Press the ISO button, then press the ISO or W.B. button to highlight your language of choice.
3. Press the MENU button. The language setting is saved.

Selecting a folder in the CompactFlash Card

If there is more than one folder in your CompactFlash Card, you can use your camera to change the folder your camera accesses. To change the folder, follow these steps.

1. Turn the camera's dial switch to **1**.
2. Press the W.B. button. The name of the folder being currently accessed appears on the right side of the LCD monitor, in the middle.
3. Press the + or - button to change the folder.

Viewing the Color Guide

The *Color Guide*, included in your Color Guide CD-ROM, contains ideas for taking pictures with your digital camera and working with your digital images, and provides useful information on color imaging.

You need one of the following browsers Set to, or an equivalent, to view the *Color Guide*.

- Netscape Navigator 3.0 or later
- Microsoft Internet Explorer 4.0 or later

If a browser is not installed in your computer, you need to obtain one and install it, or you can install the browser that comes with your Color Guide CD-ROM. For further details, double-click the Readme.txt (for Windows) or Read Me First icon (for Macintosh), and follow the instructions.

To view the Color Guide, insert the Color Guide CD-ROM and double-click your computer's CD-ROM drive icon, then double-click color.htm (for Windows) or Color Guide (for Macintosh).

Viewing and Managing Your Photos

This chapter explains how to view photos on your camera's LCD monitor, your computer monitor, or a television set. It also includes explanations on how to lock and erase photos, and how to turn the photo information display on or off with the controls on your camera.

This chapter covers the following topics.

Displaying photos on your camera, computer, television, and EPSON Projector

Erasing photos

Preventing photos from being erased

Viewing photo information

Viewing Photos with the LCD Monitor

When your camera's dial switch is in the  position, you can use the camera's LCD monitor to view your photos in a variety of ways. You can also view detailed information about each photo.

Note:

Only EPSON Photo File Format images can be enlarged, have audio recordings attached, or display photo information.

Displaying multiple photos

The PhotoPC 800's monitor can display one, four or nine photos at a time. To change the number of photos displayed, follow these steps.

1. Turn the camera's dial switch to . A photo appears on the LCD screen.

Note:

The message No Images appears when there are no photos saved in the camera's CompactFlash Card.

2. To display four images at a time, press the ISO button once. Small "thumbnail" images of the last four photos you took appear on the screen, with the currently selected image framed in white.

Press the ISO button again change the screen. Small "thumbnail" images of the last nine photos you took appear, with the currently selected image framed in white.

3. Press the + or - button to move the white frame forward or back through the images. Hold the appropriate button down to move through the images quickly.

When the frame reaches the first or last photo of the current group, the previous or next group of images is displayed.

4. To display one photo, press the ISO button.

Magnifying photos

You can view a magnified version of any image saved in your camera with the camera's LCD monitor. The size of the image four increases by four, and is divided into nine parts.

1. Turn the camera's dial switch to .
2. To magnify the currently displayed photo, press the button at the upper right of the LCD monitor.
3. A magnified view of the photo appears, and an icon in the top left corner of the screen indicates the portion of the image currently being displayed. Move the icon up and down with the + and - buttons, or right and left with the ISO and W.B. buttons.

Note:

When magnifying a panorama picture, the image is divided into three parts, and you can only scroll left and right.

4. To exit the magnification screen, press the MENU button.

Viewing a slide show of your photos

The slide show feature automatically plays back photos on your camera's LCD monitor. Your PhotoPC 800's slide show includes navigation features and gives you full control of the photos in your slide show. To use the slide show, follow these steps.

Note:

To adjust the monitor brightness, see "Setting the LCD monitor's brightness" on page 2-27.

1. Turn the camera's dial switch to .
2. Hold down the MENU button until the screen changes, then press the button next to SLIDE SHOW.
3. Press the + button to select the slide show speed. You can have the photos change automatically every three, five, or ten seconds, or you can choose to change the photos manually.

Note:

You can also rotate the photos, or exclude photos from and add photos to the slide show. See the next sections for instructions.

4. Press the button next to Start to begin the slide show.

To pause and restart the slide show, press the MENU button. When paused, you can view the previous photo by pressing the ISO button.

To stop the slide show, press the button at the lower right of the LCD monitor.

Excluding or adding photos

All photos saved in the CompactFlash Card in your camera are automatically included in the slide show. To exclude any of the photos from the slide show, or to add any excluded photos to the slide show, follow these steps.

1. Turn the camera's dial switch to .
2. Hold down the MENU button until the screen changes, then press the button next to SLIDE SHOW.
3. Press the - button.

To make choosing photos easier, you can display four or nine photos at a time by pressing the ISO button once or twice. A white frame appears around one of the photos.

Note:

A number appears in the upper left corner of each photo that is currently included in the slide show.

4. Press the + or - button to move the white frame until it is around a photo you want to exclude from or add to the slide show.
5. To exclude a photo from the slide show, press the + or - button to move the white frame until it is around the photo, then press the button next to Exclude. To exclude all the photos, press the button next to Excl'd All.

To include a photo from the slide show, press the + or - button to move the white frame until it is around the photo, then press the button next to Select. To include all the photos, press the button next to Excl'd All two times. Numbers appear in the upper left corner of each photo, indicating that they are all included in the slide show.

6. When you are finished making changes, press the MENU button, then follow steps 3 and 4 in “Viewing a slide show of your photos” on page 3-3.

Rotating photos

You can display photos in the slide show rotated 90 degrees to the right or left. To rotate a photo, follow these steps.

1. Turn the camera's dial switch to .
2. Hold down the MENU button until the screen changes, then press the button next to SLIDE SHOW.
3. Press the - button. Then, if necessary, press the + or - button to display the photo you want to rotate.
4. To rotate the photo 90 degrees in either direction, press the button next to Rotation once or twice. An icon appears on the image, indicating the orientation of the photo when displayed during the slide show.

To rotate more photos, repeat steps 3 and 4.

5. When you are finished making changes, press the MENU button, then follow steps 3 and 4 in “Viewing a slide show of your photos” on page 3-3.

Viewing photo information

You can view the following information about the currently displayed photo on the LCD monitor.

Image Number:	Folder name and number of image in the CompactFlash Card. (e) indicates the photo is based on the Design rule for camera file system.
Date:	Day/month/year and time
Shutter Speed:	1/2 to 1/750
Aperture:	f2.4 or f8
Exposure adjustment:	+2.0 to -2.0
Flash:	Indicates the flash setting used when the photo was taken.
White Balance:	Auto, fixed or custom
Others:	Icons that indicate the sensitivity and metering system settings. Icons that indicate the macro, panorama, or zoom features are being used.

To display this photo information, follow these steps.

1. Turn the camera's dial switch to .
2. Hold down the MENU button until the screen changes, then press the W.B. button.
3. To exit the photo information screen, press the MENU button.

Managing Photos with the LCD Monitor

Erasing photos

You can erase one photo, several photos, or all the photos at a time when using the LCD monitor.

Erasing individual photos

To erase photos saved in your CompactFlash Card one at a time, follow the steps below.

1. Turn the dial switch to .
2. Press the + or - button to display the photo you want to erase.

To make choosing photos easier, you can display four or nine photos at a time by pressing the ISO button once or twice. A white frame appears around the selected photo.

3. Press the W.B. button to erase the photo.

Note:

You cannot erase locked photos. To unlock a photo, see “Locking and unlocking photos” on page 3-7.

4. A confirmation message appears. Press the button next to Yes to erase the photo. Press the button next to No to cancel.

Erasing all the photos

To erase the photos from the CompactFlash Card in your camera all at once, follow these steps.

1. Turn the camera’s dial switch to .
2. Press the button next to Select Image. Then press the button next to Select All to select all the photos in the CompactFlash Card.
3. Press the ISO button to erase all the photos.

4. A confirmation message appears. Press the button next to Yes to erase the selected photos. Press the button next to No to cancel.

Note:

If any photos are locked, a message appears asking if you want to erase the locked photos. Press the button next to No to erase only the unlocked photos. Press the button next to Yes to erase all photos, including those that are locked. To lock or unlock photos, see “Locking and unlocking photos” on page 3-7.

Erasing selected photos

To erase selected photos from the CompactFlash Card in your camera, follow these steps.

1. Turn the dial switch to .

To make choosing photos easier, display four or nine photos at a time by pressing the ISO button once or twice. A white frame appears around one of the photos.

2. Press the button next to Select Image. Then press the + or - button to move the white frame until it is around a photo you want to erase.

3. To select that photo, press the button next to **Select once**. a red frame appears around the selected photo.
4. To select more photos, repeat steps 2 and 3.
5. After you have selected all the photos you want to erase, press the **ISO** button to erase them.
6. A confirmation message appears. Press the button next to **Yes** to erase the selected photos. Press the button next to **No** to cancel.

Note:

*If any photos are locked, a message appears asking if you want to erase the locked photos. Press the button next to **No** to erase only the unlocked photos. Press the button next to **Yes** to erase all photos, including those that are locked. To lock or unlock photos, see “Locking and unlocking photos” on page 3-7.*

Locking and unlocking photos

Use the lock feature to protect your photos from being accidentally erased.

Locking and unlocking all the photos

To lock or unlock all the photos in the camera’s CompactFlash Card at once, follow these steps.

1. Turn the dial switch to .
2. Press the button next to **Select Image** in the LCD monitor. The screen changes.
3. Press the same button again.
4. If **Select** appears in the lower right corner of the screen, there are some unlocked photos. Press the button next to **Select all** to select all the photos.

If **release** appears in the lower right corner of the screen, all the photos are already selected.

5. Press the button next to **Select All** to select all the photos in the CompactFlash Card.
6. Press the **W.B.** button.
7. To lock all the photos, press the button next to **Lock**.

To unlock all the photos, press the button next to **Release**.

Locking and unlocking selected photos

To lock or unlock selected photos from the CompactFlash Card in your camera, follow these steps.

1. Turn the camera's dial switch to .

To make choosing photos easier, display four or nine photos at a time by pressing the ISO button once or twice. A white frame appears around one of the photos.

2. Press the button next to Select Image. Press the + or - button to move the white frame until it is around a photo you want to lock.
3. To select that photo, press the button next to Select once. A red frame appears around the photo.
4. To select more photos, repeat steps 2 and 3.

To select all the photos at once, press the button next to Select All on the LCD monitor. All the photos are framed in red.

5. Press the W.B. button.
6. To lock the selected photos, press the button next to Lock on the LCD monitor.

To unlock the selected photos, press the button next to Release on the LCD monitor.

Erasing audio recordings

To erase audio recordings from the CompactFlash Card in your camera, follow these steps.

Note:

To make audio recordings, see “Making Audio Recordings for Photos” on page 2-22.

1. Turn the dial switch to .
2. Use the + or - button to select a photo whose attached audio recording you want to erase. (A microphone icon appears in the upper left corner of images with attached recordings.)
3. Hold down the MENU button until the screen changes.
4. Press the button next to RECORD on the monitor.
5. To erase the selected photo's audio recording, press ISO button.

If the selected photo is locked, a message appears telling you the message is also locked. To unlock the photo, press the button next to Unlock on the LCD monitor.

6. A message appears asking you to confirm whether you want to erase the audio recording. Press the button next to Yes to erase the recording, or the button next to No to cancel.
7. Press the MENU button to exit the recording screen.



Using Your Computer

You can use your PhotoPC 800 to transfer pictures saved in CompactFlash Card to your computer. This allows you to view your photos on your computer monitor and use them in your letters, presentations, or just about anything you create on your computer. You can also manage the pictures in the camera's CompactFlash Card from your computer.

To use your camera with your computer, first install EPSON Photo!3, then connect the camera to the computer. See the *EPSON Photo!3 User's Guide* for details. It contains the following information.

- Installing EPSON Photo!3 and EPSON Photo File Uploader3
- Connecting the PhotoPC 800 to your computer
- Transferring pictures to your computer
- Erasing pictures from the camera's CompactFlash Card
- Using pictures in your documents
- Uploading image files to the camera's CompactFlash Card
- Uploading programs to the camera

Note:

- When the camera is connected to your computer with a serial cable, it turns off automatically after five minutes of inactivity. It comes back on when you turn off the camera and reset its dial switch to .*
- The camera's dial switch must set to  after connecting to your computer and before you start EPSON Photo!3.*

Viewing Pictures on a Television

You can display the images in the camera's CompactFlash Card on a regular television simply by using the video cable that came with your PhotoPC 800.

Note:

Color television telecasting specifications are different depending on the country. If you have an NTSC camera model, your television must meet NTSC color television telecasting specifications. If you have a PAL camera model, your television must meet PAL specifications.

The following procedure is one example of connecting the PhotoPC 800 to your television.

1. Make sure the camera and television are turned off.

2. Open the connector cover on the side of the camera.

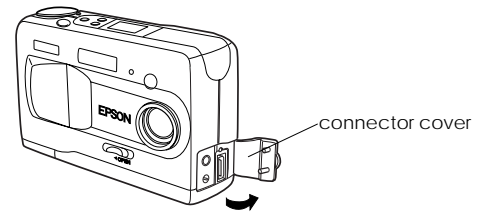

3. Connect the video cable to the VIDEO OUT port on the camera as shown below.

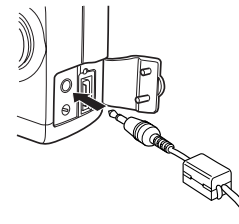

4. Connect the other end of the video cable to the video input port on the television.

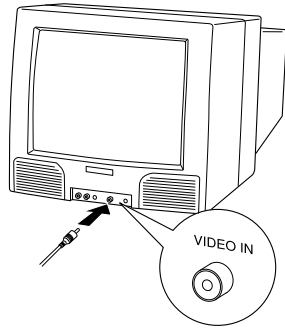

5. Turn on the television and switch it to video mode.
6. Turn the camera's dial switch to .

The last picture you took appears on the television screen and the LCD monitor turns off automatically.

Viewing Pictures with an EPSON Projector

You can display the images in your camera on an EPSON Projector by using the video cable that came with your PhotoPC 800.

See your EPSON Projector documentation for more details.

Using Direct Print to Print Photos

There are two ways to print the photos you take with your PhotoPC 800.

- ❑ You can transfer the images to your computer and print them from the application software. For instructions on transferring images, see the *EPSON Photo!3 User's Guide*.
- ❑ You can connect the PhotoPC 800 directly to your printer to print the images, using the Direct Print program installed in your camera. This chapter describes how, and includes information on the following topics.

Direct Print's features and requirements

Printing your images

LCD monitor and display panel messages

Printed image dimensions

Features

Direct Print includes the following features.

- ❑ Color, monochrome, blue, and sepia printing
- ❑ Print all, Print, Album, Sticker, and Index (contact sheet) printing modes
- ❑ Fast, Fine and Normal printing modes

Requirements

You need the following items to use the Direct Print program.

Digital camera: EPSON PhotoPC 800

Printer: Using the Direct Print Program
Ver. 3.0:

EPSON STYLUS PHOTO
EPSON STYLUS PHOTO EX
EPSON STYLUS PHOTO 700
EPSON STYLUS PHOTO 750
EPSON STYLUS PHOTO 1200
EPSON STYLUS COLOR 740

Interface cable: Macintosh serial cable
(comes with your camera)

Paper: Special papers distributed by EPSON
(See the following list.)

Photo Quality Ink Jet Paper (A3)	S041068 S041045
Photo Quality Ink Jet Paper (A4)	S041061 S041026
Photo Quality Ink Jet Card (A6)	S041054
Photo Quality Ink Jet Paper (Letter)	S041029 S041062
Photo Paper (A3)	S041142
Photo Paper (A4)	S041140
Photo Paper (4 × 6)	S041134
Photo Paper (Letter)	S041141
High Quality Glossy Film (A4)	S041071
Photo Quality Glossy Film (A6)	S041107
Photo Quality Glossy Film (Letter)	S041072
Photo Stickers (A6)	S041144
Photo Stickers 4 (A6)	S041176

Note:

- ❑ *The availability of special media varies by country.*
- ❑ *Ink jet printers are particularly sensitive to the condition of your paper. Keep unused paper in its original packaging and store it in a cool, dark place.*
- ❑ *Using the optional AC adapter (B86706*) with your camera is recommended. This avoids interrupted printing caused by low battery power.*

Connecting your camera to the printer

Follow these steps to connect your camera to a printer.

1. Make sure both the camera and the printer are turned off.
2. Connect one end of the Macintosh serial cable to the serial connector on the back of the printer.

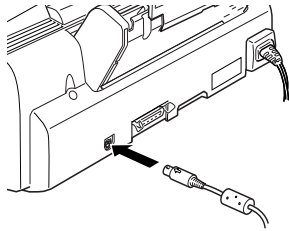

3. Open the connector cover on the side of the camera.

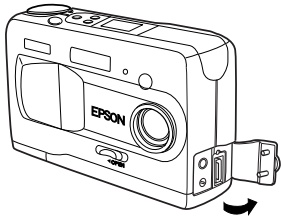

4. Plug the connector cable into the camera's interface port.

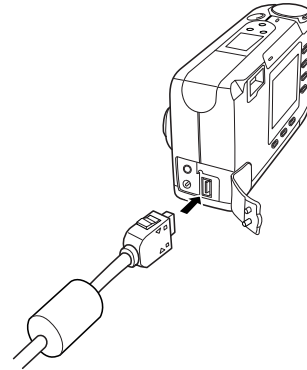

Caution:

Be sure to position the cable correctly before pushing it into the connector. Otherwise, the cable's pins may be damaged.

Installing the Direct Print Program

Your PhotoPC 800 comes with Direct Print Ver. 3.0 installed. If you uninstalled the program and want to use it again, you can reinstall the program from the included CD-ROM.

You can install Direct Print in your camera from your computer using EPSON Program Uploader. This utility is installed in your computer automatically when you install the EPSON Photo!3. To install these programs, see the *EPSON Photo!3/File Uploader3 User's Guide*.

Once EPSON Program Uploader is installed in your computer, follow these steps to install Direct Print to your camera.

Note:

You can also install the Direct Print program using a CompactFlash Card. For instructions on using these cards, see "Copying or deleting programs using a CompactFlash Card" on page 5-4.

1. Make sure both the camera and the computer are turned off.

2. When connecting to the serial interface, plug the serial cable connector into the serial port (for Windows) or the modem port or printer port (for Macintosh) on your computer.

When making a USB connection, plug the USB cable connector into the USB port on your computer.

3. Open the connector cover on the side of the camera.
4. Plug the other end of the cable into the camera's interface port.



Caution:

Be sure to position the cable correctly before pushing it into the connector. Otherwise, the cable's pins may be damaged.

5. Turn on your computer and insert the software CD-ROM in the disk drive.
6. Turn your camera's dial switch to .
7. Click or double-click the EPSON Program Uploader icon in the EPSON Photo!3 program group or folder. The EPSON Program Uploader3 window appears.

Note:

If a message appears indicating the camera is not properly connected to the computer, check the cable connection and make sure the camera's dial switch is set to . Then click OK.

8. Click Browse and select your CD-ROM drive. Then click the OP-PROG folder, and click OK.
9. Select an application from the Direct Print in Folder list to upload.
10. Click Upload. EPSON Program Uploader begins uploading the selected programs.

When the uploading process is finished, the uploaded programs appear in the Applications in Camera list.

11. Click Close.

You can delete the Direct Print Program from your camera using the Program Uploader Utility. See the *EPSON Photo!3/File Uploader3 User's Guide* for instructions. You can also use your PhotoPC 800 to delete the program from a Compact Flash memory card. See "Copying or deleting programs using a CompactFlash Card" on page 5-4.

Printing Your Images

The Direct Print program controls all the print settings between your camera and the connected printer. After accessing Direct Print, use it to select a layout before printing your images.

Accessing the Direct Print program

1. Connect your camera and printer. (See "Connecting your camera to the printer" on page 4-3.)
1. Make sure the printer is off, then turn your camera's dial switch to .
2. Press the button next to DirectPrint on the LCD monitor. The Direct Print program's top menu appears on the monitor.

To decide a print format, see the next section.

Choosing a print format

The Direct Print program features five different formats. This section shows each format, and includes 9 charts with each format's available settings. Before printing, choose a format from the following diagrams.

Print All / Print format

The Print All format prints all the photos in the memory card. The Print format prints individual photos. You can print one to four images onto a sheet of paper depending on the paper size. You can also print several copies of individual images.

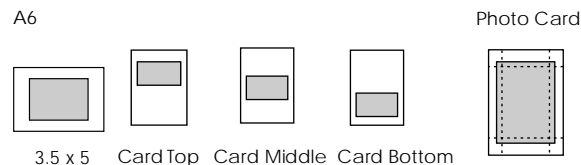
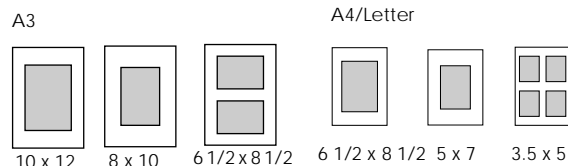

Item	Choices
Paper Size	A3, A4, Letter, A6, PhotoCard
Layout	10 x 12, 8 x 10, 6.5 x 8.5, 5 x 7, 3.5 x 5, PhotoCard, Card Top, Card Middle, Card Bottom,
Information	On or Off (Date and Time)
Filter	None, Monochrome, Sepia, Blue
Paper Type	Glossy Paper, Glossy Film, Inkjet Paper
Print Mode	Fine, Fast, Normal

❑ **Index format**

Prints small “thumbnail” images of all the photos in your camera on A4, Letter, or A6 size contact sheets.

Item	Choices
Paper Size	A4, A6, Letter
Layout	Index
Information	On or Off (A6 size: The number of the photo A4 / Letter size: The number of the photo, date)
Filter	None
Paper Type	Glossy Paper, Glossy Film, Inkjet Paper
Print Mode	Fine, Fast, Normal

A4/Letter

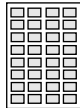

A6



❑ **Album format**

Prints up to three images on A4 or Letter size paper. Photos are placed on the left. You can rotate the photos when printing two on a sheet.

Item	Choices
Paper Size	A4, Letter
Layout	Album
Information	On or Off (The number of the photo, date, time, shutter speed, aperture, audio recordings, ruled line)
Filter	None, Monochrome, Sepia, Blue
Paper Type	Glossy Paper, Glossy Film, Inkjet Paper
Print Mode	Fine, Fast, Normal

A4/Letter

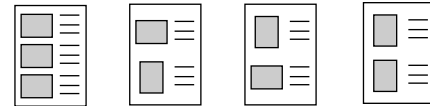

- **Sticker format**
Prints onto EPSON Photo Stickers. You can print 16 small copies (for Photo Stickers) or four small copies (for Photo Sticker 4) of the selected image onto each Photo Sticker sheet.

Item	Choices
Paper Size	Sticker 16, Stickers 4
Layout	Sticker 16 1 photo x 16, 2 photos x 8, 4 photos x 4 Stickers 4 1 photo x 4, 2 photos x 2
Filter	None
Paper Type	Glossy Film
Print Mode	Fine, Normal

Sticker 16



Stickers 4



Printing procedures

Making settings

Before printing, you need to make the print format, paper size, layout, photo information, and filter settings. Follow these steps to make each setting.

1. Access the Direct Print program as described in “Accessing the Direct Print program” on page 4-5.
2. Press the button next to the format you want to use.
3. To select a paper size, press the button next to Paper Size on the LCD monitor.
4. To select a layout, press the button next to Layout.
5. Press the button next to Information to change the information setting. To print Photo information under the photo, select On.
6. Press the button next to Filter to select the filter.

Keep the camera on and go to the next section to select a photo to print.

Note:

- ❑ *The available settings and the information contents vary depending on the print mode you have selected. See the previous section for more information on each mode.*
- ❑ *When you select Photo Card as the paper size, you cannot display photo information.*

Selecting the photo

Follow these steps to select the photo you want to print.

1. Press the button next to Photo Selection. Thumbnail images of the first nine photos in the memory card appear.

When using the Print All or Index format, all photos in the memory card are already selected. Skip to step 4.

When using the Print, Album, or Sticker format, the currently selected image is framed in white.

2. Press the ISO or W.B. button to frame the image you want to print.

3. Press the + button to print one copy of the framed image. A check mark appears on the image you select. Press the + or - button to change the number of copies. If you change the number to 0, the check mark disappears.

To rotate the photo 90 degrees in either direction, press the button next to Rotation once or twice. An icon appears on the image, indicating the orientation of the photo when printing.

Note:

- ❑ *You can print up to 99 copies when using the Print All or Print format. You can only print one copy when using the other formats.*
- ❑ *Depending on the format, you may not be able to rotate the photo.*

4. When you finish making settings, press the MENU button.
5. A confirmation message appears. To continue, press the button next to Done.

To change the settings, press the button next to Cancel, and go back to step 1.

To reset the settings, press the MENU button, and go back to step 2.

Printing the photos

1. To start printing, press the ISO button. The current print settings appear on the screen.

Note:

To change the print settings, press the W.B. button, then remake the settings.

2. Press the + button to select the paper type. The available paper type and print mode vary depending on the selected paper format.
3. To change the print quality setting, press the button next to Print Mode. You can choose between Normal, Fine and Fast.

Note:

For information on paper types and print modes, see your printer's documentation, and the instructions that came with your media.

4. To adjust the position of the paper, press the button next to Adjust. You can adjust the position left, right, up, or down a total of 10 mm, in increments of 0.2 mm. When you finish adjusting the position, press the MENU button.

5. Turn on the printer and load the size and type of media you selected. For loading instructions, see your printer's documentation, and the instructions that came with your media.
6. Press the ISO button to print. The camera starts sending image data to the printer.

While the camera sends data and prints, the LCD monitor goes blank, star icons move across the display panel on the top of the camera, and the status light flashes green.

Note:

To cancel printing, hold down the camera's MENU button. A message stating printing is cancelled appears on the LCD monitor for five seconds. The printer stops printing and ejects the media.

7. When you finish printing, press the MENU button to exit the Direct Print program. Then turn the camera's dial switch to Off and turn off the printer.

LCD Monitor and Display Panel Messages

When printing with the Direct Print program, a variety of status messages may appear on the camera's LCD monitor or the printer's display panel. For detailed explanations of these messages, see the following tables.

LCD monitor messages

Message	Explanation
No Photos in Memory.	This message appears when there are no photos in memory. Press the button next to OK to return to the previous screen.
Please Select at least one photo to print.	There are no photos selected. Press the button next to OK to return to the previous screen and select a photo.
Unsupported printer model. Please connect supported model.	The camera is not connected to an appropriate printer. Connect the camera to a printer described on page 4-2, then press any button to make print settings. (To cancel printing, hold down the MENU button.

	You selected a Paper Size that your printer does not support. Select an appropriate paper size. (For information on available paper sizes, refer to your printer's documentation.)
Connection or printer error.	Printing was interrupted because of a printer error. Clear the error, then start printing again from the beginning. (For information on clearing printer errors, see your printer's documentation.)
OK to erase printing settings?	You are about to erase the current print settings. To erase the settings, press the button next to YES.
Batteries are low. Use AC adapter.	Battery power is almost out. Connect the camera to the AC adapter.
Error. Settings reset to default.	An error occurred while the Direct Print program was working. The settings you have made returned to their default values. To go back to the previous screen, press the button at the bottom next to OK.

Insert a Memory Card in the camera.	There is no memory card in the camera. Insert a CompactFlash Card. For instructions, see "Installing and removing a CompactFlash Card" on page 1-9.
Printing canceled.	You held down MENU button while printing. The printer stops printing and ejects the paper. This message disappears after three seconds.
Printing canceled. Reset printer and camera.	An error occurred. The printer stops printing and ejects the paper. This message disappears after three seconds.

Display panel messages

Message	Explanation
E51: Another interface is active	The printer is receiving a print job through another interface. When the print job ends, the printer begins printing from the Direct Print program automatically.
E55: No ink	Printing stopped because the printer ran out of ink. Replace ink cartridges as needed and start printing again from the beginning. (For information on replacing ink cartridges, see your printer's documentation.)
E56: No paper or paper jam	Load paper into the printer, then press the printer's  load/eject button to begin printing. (Or hold down the camera's MENU button to cancel printing.) Printing stopped because paper is jammed in the printer. To remove the paper from the printer, see your printer's documentation.

Printed Image Dimensions

Print All /Print format

Layout setting	Paper Size setting	Image Dimensions
10 x 12	A3	339 x 254 mm
8 x 10	A3	271 x 203 mm
6.5 x 8.5	A3 / A4 / Letter	220 x 165 mm
5 x 7	A4 / Letter	180 x 136 mm
3.5 x 5	A4 / Letter / A6	128 x 89 mm
Photo card	Photo Card	158 x 106 mm
Card	A6	89 x 67 mm

Index format

A4/Letter: 36 x 27 mm

A6: 23 x 17 mm

Album format

A4/Letter: 109 x 81 mm

Sticker format

Sticker 16: 27 x 20 mm

Stickers 4: 56 x 42 mm

Camera Options and Accessories

This chapter covers the variety of available options that expand the memory and flexibility of your PhotoPC 800.

The following topics are included in this chapter.

Using CompactFlash Memory Cards

Using the PCMCIA adapter

Using the AC adapter

Using CompactFlash Memory Cards

The PhotoPC 800 comes with 2 MB of internal memory mainly for storing optional software programs, and an 8 MB CompactFlash Card to store photos.

Note:

You must install a memory card in your PhotoPC 800 before you can take pictures. To install a memory card, see “Installing and removing a CompactFlash Card” on page 1-9.

The following table shows the storage capacity of each CompactFlash Card.

	Standard	Fine	Super fine	HyPict
8 MB* CompactFlash Card	120	24	12	10

Note:

- ❑ *The number of photos you can save on a memory card may differ slightly from the chart above, depending on the complexity of each photo.*
- ❑ *If you attach an audio recording to a photo saved in your memory card, the number of photos you can save on that card may decrease.*

*For information about the availability of CompactFlash Cards in your area, contact your EPSON dealer.

Installing a CompactFlash Card into your computer

You can install a CompactFlash Card into a computer equipped with a Type II PCMCIA memory card slot. This allows you to copy photos directly from your CompactFlash Card to your computer, and to copy programs to or erase programs from your camera using your CompactFlash Card. Follow these steps.

1. If necessary, remove the CompactFlash Card from the camera. See “Installing and removing a CompactFlash Card” on page 1-9.

2. Insert the CompactFlash Card all the way into the optional adapter, as shown below.

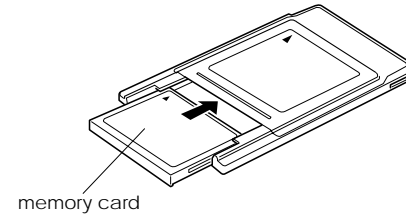

3. Insert the adapter into your computer's Type II PCMCIA slot.

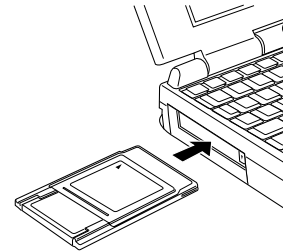

To copy photos from a CompactFlash Card to your computer, see the next section.

To copy programs to or erase programs from your camera using your CompactFlash Card, see “Copying or deleting programs using a CompactFlash Card” on page 5-4.

Copying photos directly to a computer

To copy photos directly from your CompactFlash Card to your computer, follow these steps.

Note:

- ❑ *Macintosh users must enable the PC Exchange extension software to access files on memory cards. See your Macintosh documentation for more information.*
 - ❑ *You can also access the photos in your memory card with the included EPSON Photo!3 software. For instructions, see the EPSON Photo!3 User’s Guide.*
1. Install the memory card into your computer. See “Installing a CompactFlash Card into your computer” on page 5-2.
 2. Find and double-click the DCIM folder in your computer. Then double-click the 100EPSON folder. Your image files appear.
 3. Double-click a file to view its thumbnail image.

4. Copy photos to the desired folder in your computer.

Note:

- ❑ *The PhotoPC 800 saves files in the automatically generated 100EPSON folder.*
- ❑ *Files saved with the Save To Folder button are named automatically. For example, 91020001. The first digit, 9, is the last number of the year you took photo. The next digit, 1, is the month, January. (October, November, and December are represented by X, Y, and Z, respectively.) The next two digits, 02, represent the day. The last four digits, 0001, indicate the order the file was saved. Image files use the JPG extension, and audio recording files use the WAV extension.*

Copying or deleting programs using a CompactFlash Card

To copy programs to or erase programs from your camera using your CompactFlash Card, follow these steps.

Note:

- ❑ *You can also upload programs to your memory card from your computer using the EPSON Program Uploader utility. See EPSON Photo!3 User's Guide.*
 - ❑ *Macintosh users must enable the PC Exchange extension software to access files on CompactFlash Cards. See your Macintosh documentation for more information.*
1. Install the memory card into your computer. See "Installing a CompactFlash Card into your computer" on page 5-2.
 2. Create a folder in the card and name it OP-PROG.
 3. Copy the opld8001.prg file from the CD-ROM's OP-PROG folder to the memory card's OP-PROG folder.

Note:

Be sure to copy the opld8001.prg file into the OP-PROG folder, even when you want to delete a program from your camera. Otherwise, you cannot delete or copy programs.

4. Copy the program file you want to install in your camera to the memory card's OP-PROG folder.
5. Remove the CompactFlash Card from the computer and insert it in the camera.
6. Turn the camera's dial switch to **■**.
7. Press the camera's W.B. button.
8. Press the button next to EXT SOFT on the camera's LCD monitor.
9. To copy a program to the CompactFlash Card, press the + button.

To delete a program from the camera, press the - button.
10. To choose the program you want to add or delete, press the + or - button, then press the button next to Add or Delete.

11. A confirmation message appears. Press the button next to Done to add or delete the program, or press the button next to No to cancel.

Formatting memory cards

The included CompactFlash card is already formatted when you buy it. You need to format a card only if you want to erase all the data on the card, or if a message on the LCD screen instructs you to do so.

To format CompactFlash Cards, follow these steps.



Caution:

When you format a memory card, all the data on the card is lost, including any locked images.

1. Make sure the memory card is installed in the camera. See “Installing and removing a CompactFlash Card” on page 1-9.
2. Turn the camera’s dial switch to **1**. Then press the W.B. button.
3. Press the button next to MEMORY CARD FORMAT to format the memory card.

Note:

If no memory card is installed in the camera, you cannot select MEMORY CARD FORMAT.

4. A confirmation screen appears on the screen. Press the button next to Yes to format the card. Press the button next to No to cancel.

Note:

If any photos in the memory card are locked, a message appears telling you that the photos will be erased if you reformat the card. Press the button next to Yes to format the card. Press the button next to No to cancel.

Using the AC Adapter

The AC adapter (B86706*) allows you to connect your PhotoPC 800 to a standard electrical outlet. This is especially useful when you are previewing pictures, transferring pictures, operating the camera from your computer or using Direct Print. The adapter powers the camera, but does not charge the batteries. In some locations the AC adapter comes with a separate AC power cable.

Note:

- ❑ *The asterisk in the product number (B86706*) is a substitute for the last digit, which varies by country.*
- ❑ *Also read the AC adapter's documentation before using this product.*



Warning:

- ❑ *Use only the AC adapter designed for the PhotoPC 800. Using any other adapter could cause fire, electrical shock, or injury.*
- ❑ *Do not use the AC power cable and the adapter for any purpose other than powering your PhotoPC 800.*
- ❑ *If the AC plug does not fit your outlet, have a proper outlet installed by a qualified electrician.*
- ❑ *To avoid radiation danger, do not expose or remove the ferrite core.*
- ❑ *To prevent fire or electric shock, do not cover the camera with a blanket.*

To avoid losing any images or settings, make sure the camera is finished processing and is turned off before you connect or disconnect the AC adapter. Then follow these steps.

1. If your AC adapter has a separate AC power cable, push the cable connector firmly into the AC inlet.

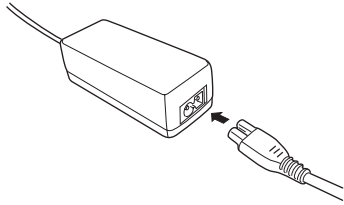

2. Open the connector cover on the side of the camera.
3. Plug the adapter cable into the DC port on the camera.

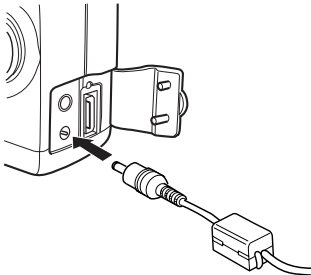

4. Plug the AC adapter into an electrical outlet.



Caution:

- ❑ Place the camera and the AC adapter near an electrical outlet where the plug can be easily unplugged.

Note for French-speaking users:

Placez l'appareil photographique et ses options près d'une prise de courant où la prise peut être débranchée facilement.

- ❑ Avoid electrical outlets controlled by wall switches or automatic timers. Also, avoid outlets on the same circuit as large motors or other appliances that can cause fluctuations in line voltage.

Maintenance and Troubleshooting

Your PhotoPC 800 is easy to take care of, and any problems you may have can be solved quickly and easily.

See the following section for guidance on cleaning and storing the camera. For solutions to common camera problems, see the section beginning on page 6-3.

Handling, storing and cleaning the camera

Cleaning the battery charger

Solutions for camera and image problems

Maintenance

Your PhotoPC 800 requires only basic care. Before you do any maintenance procedures on the camera, be sure to read “Safety Instructions” on page 3. Then follow these guidelines.

Handling the camera

- ❑ To avoid damaging the optics of the camera, do not expose the lens to direct sunlight for extended periods of time.
- ❑ Avoid sudden temperature changes, which can cause moisture to form on the camera and options. Keep the camera and options in a case or bag if you need to move them from a cold environment to a warm one. Allow time for the camera and options to adjust to temperature changes before using them.

Cleaning the camera

- ❑ Use a clean, dry cloth to keep the camera free of dust.
- ❑ Do not use harsh or abrasive cleaners.
- ❑ To clean the lens, make sure the camera is off, then blow off any loose dust or dirt. Next breathe on the lens and wipe off all moisture with a soft, lint-free cloth or lens cleaning tissue.
- ❑ If necessary, clean the battery contacts with a dry cloth.

Storing the camera

If you will not use the camera for a long period of time, remove the batteries and store them at a low temperature in a dry location and store the camera in its case. This prevents camera damage from battery leaks or corrosion.

Do not store the camera in the following locations.

- ❑ Where it will be exposed to direct sunlight; for example, on a car dashboard
- ❑ Near sources of bright light or high humidity
- ❑ Near sources of heat or in a closed car
- ❑ In areas of excessive dirt or dust
- ❑ Where it will be exposed to strong vibrations or magnetic fields

Cleaning the battery charger

- ❑ Disconnect the battery charger from the power outlet before cleaning.
- ❑ Do not use liquid, aerosol, harsh or abrasive cleaners.
- ❑ Wipe off dust with a clean, dry cloth.
- ❑ Keep the charger terminals clean by wiping them with a dry cloth.

Problems and Solutions

Check this list of problems and possible solutions before calling your dealer for help.

Camera problems

The camera has no power.

The camera may have turned off automatically. To turn the power back on, turn the camera off and back on again. Alternatively, you can turn the camera back on by pressing the shutter button, or pressing a button on the back of the camera, depending on your camera's dial switch position. See "Turning the camera back on" on page 2-27 for more details.

Make sure the batteries are installed correctly. See "Installing the batteries" on page 1-6. Also, make sure you are using appropriate batteries and that they are charged. See "Replacing the batteries" on page 1-7 and replace the batteries if necessary.

The batteries included with the camera need to be charged before use. See "Charging the batteries" on page 1-4 to charge the batteries.

If you are using the AC adapter, make sure it is plugged into a working outlet.

The camera doesn't take a picture after you press the shutter button.

Make sure the lens cover is open. If the lens cover is closed, open it by sliding the switch on the front of the camera in the direction of the arrow.

The flash may be recharging. Wait until the shooting light beside the viewfinder turns green, and try again.

Make sure the CompactFlash memory card is installed correctly. To install a memory card see "Installing and removing a CompactFlash Card" on page 1-9.

The camera's memory may be full. Check the picture counter on the display panel. If it reads 0, your camera's memory is full. Erase some pictures using the LCD monitor, or transfer the pictures to your computer and then erase them.

Note:

To erase pictures with the LCD monitor, see page "Erasing photos" on page 3-5. To transfer pictures to your computer before erasing them, see the EPSON Photo!3 User's Guide.



The camera may be connected to your computer. When it is connected, you cannot use any of the buttons on the camera itself. See the *EPSON Photo!3 User's Guide* for instructions on taking pictures from your computer.

The camera takes too long to take a picture after you press the shutter button.

You may be pressing the shutter button all the way down at once. This forces the camera to focus, make exposure adjustments, and capture the image all at once. You can have the camera perform these operations separately to make the process more efficient. First, hold the shutter button halfway down to lock the auto focus, then press the shutter button the rest of the way down to take the photo. For more information, see “Taking Pictures Using the Viewfinder” on page 2-4, or “Taking Pictures Using the LCD monitor” on page 2-10.



If you want to take pictures quickly in succession, use the quick shooting feature. This will reduce the amount of time that the camera normally takes to process each picture. See “Quick shooting feature” on page 2-26.

The flash does not work.

Make sure the flash is set to ,  or . See “Setting the flash” on page 2-8 for more information on setting the flash.

Make sure the batteries are installed correctly. See “Installing the batteries” on page 1-6. Also, make sure you are using appropriate batteries and that they are charged. See “Replacing the batteries” on page 1-7 and “Charging the batteries” on page 1-4.

When the camera is in the continuous shooting mode, the flash is disabled.

Nothing appears on the LCD screen when the camera's dial switch is set to ,  or .

Make sure the batteries are installed correctly. See “Installing the batteries” on page 1-6. Also, make sure you are using appropriate batteries and that they are charged. See “Replacing the batteries” on page 1-7 and “Charging the batteries” on page 1-4.

The camera may have turned off automatically. To turn the power back on, turn the camera off and back on again. Alternatively, you can turn the camera back on by pressing the shutter button, or pressing a button on the back of the camera, depending on your camera's dial switch position. See "Turning the camera back on" on page 2-27 for more details.

The LCD monitor turns off automatically when connected to the TV, or when you use EPSON Photo!3.

The image on the LCD monitor screen is too dark, or is not visible at all.

Adjust the brightness of the LCD screen if necessary, following the instructions in "Setting the LCD monitor's brightness" on page 2-27.

Make sure the dial switch is set to ,  or .

The LCD monitor turns off automatically when connected to the TV, or when you use EPSON Photo!3.

You cannot take certain kinds of pictures or make the settings you want when using the LCD monitor.

Some of the camera's settings and features cannot be used at the same time. For example, you cannot use the quick shooting feature and set the image quality to HyPict at the same time. For instructions on making camera settings, see Chapter 2, "Taking Pictures".

To adjust the white balance, exposure, and sensitivity settings, you must first select the Program or Manual camera mode. See "Making the camera mode setting" on page 2-24.

Nothing appears on the TV monitor when the camera is connected to your television.

Make sure the video cable is connected correctly, "Viewing Pictures on a Television" on page 3-10.

Make sure the camera's dial switch is set to .

Make sure the television is switched to the video mode.

Make sure the batteries are installed correctly. See “Installing the batteries” on page 1-6. Also, make sure you are using appropriate batteries and that they are sufficiently charged. See “Replacing the batteries” on page 1-7 and “Charging the batteries” on page 1-4.

Your camera may not be compatible with local television broadcasting standards. Cameras purchased in countries using the NTSC standard can only be used with NTSC televisions, and cameras purchased in countries conforming to the PAL standard can only be used with PAL televisions.

Note:

Also, see your television documentation for possible solutions.

You cannot take a picture with the camera when a CompactFlash Card is installed.

Check your camera’s LCD monitor for messages. If you get a message indicating that you need to format or eject the card. To format the memory card, see page “Formatting memory cards” on page 5-5. To remove the card, see “Installing and removing a CompactFlash Card” on page 1-9.

Your card’s memory may be full. Check the picture counter on the display panel. If it reads 0, the memory is full. In this case, change to another card, erase some pictures using the LCD monitor, or transfer the pictures to your computer and then erase them.

Note:

To erase pictures with the LCD monitor, see page “Erasing photos” on page 3-5. To transfer pictures to your computer before erasing them, see the EPSON Photo!3 User’s Guide.

Even after you take a picture, the number on the display panel stays the same.

This number shows how many more pictures you can take. The number may not change, depending on the image quality or complexity of the photos you take.

You cannot copy software to or delete it from the memory card.

Make sure the memory card is installed correctly. See “Installing and removing a CompactFlash Card” on page 1-9, and reinstall the memory card if necessary.

Make sure the memory card contains the folder and files necessary to copy or delete the program. See “Copying or deleting programs using a CompactFlash Card” on page 5-4.

Picture problems

If you are not satisfied with the pictures you get from your PhotoPC 800, you may need to adjust some of the camera's settings, or you may need to brush up on your photography techniques. Read the suggestions listed below and give them a try.

Your pictures images on the screen and printed out differ from the image displayed on the LCD monitor.

The PhotoPC 800 captures images in 24-bit color (16 million colors). Your pictures will not display maximum image quality if your monitor or your computer's video controller does not support this color depth. You may need to upgrade your system to achieve the best possible image quality.

The image on the LCD monitor and screen are different, check the gamma correction and color correction settings. Try a different combination of these settings.

If your pictures look better on the screen than when you print them out, you may need to upgrade your printer. EPSON color ink jet printers provide excellent image quality.

Your picture is blurry or out of focus.

Make sure your subject is within the camera's range. When sensitivity is set to Standard, make sure you are at least 50 centimeters away from the subject to take a picture without the flash, or 50 to 340 centimeters away to take a picture with the flash. When using the macro feature, you can take pictures within 15 to 50 centimeters of the subject with or without the flash.



Make sure the subject is not moving.

Be careful to hold the camera steady while the image is being captured.

Make sure your flash is not set to .

Make sure to center your subject. When you take photos using the viewfinder, center your subject in the cross-hairs.

Your picture is too dark (underexposed).

You may need to use the flash. Set the flash to ,  or , following the instructions in “Setting the flash” on page 2-8.

If you are using the flash, make sure your subject is within 50 to 340 centimeters of the camera.



When sensitivity is set to Standard and you are using the macro feature, stay 15 to 50 centimeters away from the subject.

You can adjust the exposure to make your photos brighter. See “Making basic exposure adjustments” on page 2-16, or “Making advanced exposure adjustments” on page 2-17.

Use image-editing software to adjust the picture's brightness and contrast.

If you are using the macro feature to take close-up photos, be sure to provide adequate lighting for your subject, since the camera's aperture is automatically set to the smallest.

Your picture is too light (overexposed).

If you are using the forced flash  setting, the flash may be too bright. Try setting the flash to the automatic  setting. See “Setting the flash” on page 2-8.

You can adjust the exposure manually to make your photos darker. For instructions, see “Making advanced exposure adjustments” on page 2-17.

When you use the flash and the macro function together, you may find your pictures come out too light, since the flash is close to the subject. In this case, try turning the flash off .

If you are facing a bright light source, you may need to take your picture from a different angle.

You can adjust the exposure to make your photos brighter. See “Making basic exposure adjustments” on page 2-16, or “Making advanced exposure adjustments” on page 2-17.

Use image-editing software to adjust the picture's brightness and contrast.

Part of your picture is missing.

Make sure you are not blocking the lens with your finger, strap, clothing, or other object.

A horizontal or vertical red line appears on your picture.

Red lines are caused by glare. Avoid photographing very shiny surfaces that reflect light into your lens.

The wrong date and/or time is displayed on your camera.

If you remove the batteries from your camera for a certain time period, you will need to reset the clock. See “Setting the time and date” on page 2-24 to set the clock using the LCD monitor. You can also set the clock from your computer. For instructions, see the *EPSON Photo!3 User's Guide*.

The color in your picture does not look right.

When you take pictures under certain artificial lighting conditions, the colors may be slightly distorted. You can use image-editing software to adjust color.

When you want to get more realistically colored images (for example, reddish images at dusk), set the white balance to FIX. For instructions, see “Adjusting the white balance setting” on page 2-14.

Your pictures do not look as good as they used to.

Your camera's lens may be dirty or dusty. Try cleaning it following the instructions in “Cleaning the camera” on page 6-2.

The area captured in the photo is different from what you saw in the viewfinder.

Take care to look straight through the viewfinder.

When taking photos using the macro feature, be sure to use the LCD monitor rather than the viewfinder to frame your subject.

Keep in mind that the area visible through the viewfinder is slightly smaller than the area captured in the actual photo.

Specifications

Camera

Physical dimensions

Width	113 mm
Height	67.5 mm
Depth	35.5 mm
Weight	235 g (without batteries, strap and CF card)
Temperature	Operating: 5 to 35°C Non-operating: -20 to 60°C
Humidity (non-condensing)	Operating: 30% to 80% Non-operating: 10% to 80%

Product type

Type	Digital still AF camera with LCD monitor
CCD	1/2 inch color area CCD (2.1 M pixels)
Zoom	Digital 2× zoom
LCD monitor	1.8-inch TFT color LCD monitor (110 K pixels)
Internal ROM	2 MB (program memory only)

Recorded image

Data type	JPEG image follow Exif Ver.2.1 and recorded based on Design rule for camera file system(16 million colors, 24bit) Note: Exif is a standard format for audio/image files. Design rule for camera file system is a recording standard for image files. These standards have been established by Japan Electronic Industry Development Association (JEIDA).
Image size	1984 × 1488 pixels (HyPict), 1984 × 744 pixels (Panorama HyPict), 1600 × 1200 pixels (Super Fine), 1600 × 1200 pixels (Fine), 1600 × 600 pixels (Panorama Super Fine), 1600 × 600 pixels (Panorama Fine), 640 × 480 pixels (Standard)

Image quality modes	HyPict (1984 × 1488 pixels, 1984 × 744 pixels) Super fine (1600 × 1200 pixels, 1600 × 600 pixels) Fine (1600 × 1200 pixels, 1600 × 600 pixels) Standard (640 × 480 pixels)
Alternative formats	Monochrome, macro, digital 2× zoom, panorama, continuous shooting, slow flash, quick shooting

Optical

Lens	f = 7 mm (equivalent to a 38 mm lens on a 35 mm camera) F2.4/8.0
Focal length	0.5 m to infinity 0.15 m to 0.5 m (macro mode)
Focus	Auto focus / Manual focus
Sensitivity	Equivalent to ISO 100/200/400
Aperture	f2.4, f8.0
Shutter	Electric iris with mechanical shutter 1/2 second to 1/750 second (flash off mode), 1/30 second to 1/750 second (auto flash and forced flash modes)
Exposure control	Divided brightness metering Program Auto, Spot metering Program auto, exposure Manual adjustment (-2 EV to +2 EV, 9 or 21 step)
White balance	TTL automatic white balance Fixed mode (sunlight) User defined mode

Viewfinder	Real-image optical (view range approx. 90%)
Self timer	Ten seconds
Flash	Automatic luminance control flash
Flash modes	Automatic, forced flash, flash off, Slow Synchro

Flash Range

Sensitivity setting	Range
Std. (ISO 100)	0.5 ~3.4 m
Med. (ISO 200)	0.5 ~4.9 m
High (ISO 400)	0.5 ~6.9 m

Functional

Photo processing time (approximate)

	Photo processing time	Photo processing time for quick shooting	Photo processing time for replay
Standard	1.2	1.0	0.5
Fine	2.1	1.2	1.0
Super fine	2.5	1.2	1.5
HyPict	12	-	2.0

Interface

Serial interface 14-pin dual line terminal, RS-232C-compatible special interface for PC, Macintosh
Communication speed: 19.2 Kbps or higher, max 230 Kbps (for Windows and Macintosh serial cable)
Max. 12 Mbps (for the USB cable)
900K bps or 1.8 Mbps (for EPSON printers)

Video out

NTSC (NTSC model)
PAL (PAL model)

Power

Sources

DC 1.2 V × 2 (2.4 V)
Ni-MH Batteries
Model EU-24
DC 3.4 V
Optional AC Adapter
Model EU-37

Battery life

(when using two of the included Ni-MH batteries)

Taking photos with View Finder	Approx. 850 pictures
Taking photos with LCD monitor (Automatic shut-off is set to 10 seconds)	Approx. 100 pictures
Playing back photos	Approx. 55 min.

Battery Charger

Model EU-38

Input	AC 100 - 240V, 50 - 60 Hz
Output	DC 1.2 V 490 mA × 4
Compatible batteries	EPSON Ni-MH Batteries (Model EU-24)
Charging time	2 batteries: Approx. 110 min. (Max. 120 min.) 4 batteries: Approx. 210 min. (Max. 240 min.)
Power consumption	Approx. 8 W
Charging temperature	5 to 35°C
Dimensions	76 × 115 × 28 mm
Weight	Approx. 130 g

Battery

Model EU-24

Type name	Cylindrical sealed Nickel-Metal Hydride rechargeable battery
Size	AA / IEC LR6 compatible
Ratings	DC 1.2 V
Temperature	Charging: 5 to 35°C Storage: -20 to 30°C
Humidity	45 to 85% RH
Weight	Approx. 25 g per cell

CompactFlash Card

Storage capacity 8 MB*

Note:

For information about the available CompactFlash Card, contact your EPSON dealer.

Physical Dimensions:

Width 42.8 mm

Height 36.8 mm

Depth 3.3 mm

Optional PCMCIA Adapter

Interface PCMCIA PC Card ATA

Card slot type Type II

Physical Dimensions:

Width 54.0 mm

Height 85.6 mm

Depth 5.0 mm

Optional AC Adapter

Model EU-37

Input AC 100 - 240 V, 50 - 60 Hz

Output DC 3.4 V, 2.5 A

Power Consumption Approx. 0.3 A, 14W

Physical Dimensions:

Width 43 mm

Height 31 mm

Depth 104 mm

Weight Approx. 210 g
(Without AC plug)

Contacting Customer Support

If your camera is not operating properly and you cannot solve the problem using the troubleshooting information in this guide, contact customer support services for assistance.

To help us assist you more quickly, please provide the following information.

Serial number of your camera

(See the label on the bottom of the camera.)

Camera model

Brand and model of your computer

EPSON Photo!3 software version

(Click About in the Setup menu.)

Windows version you are using

(For example, 95 or 98)

Software applications you normally use with your camera and their version numbers

Note:

EPSON recommends making back-ups of your images before sending your camera for repairs. EPSON is not responsible for any lost images.

For United Kingdom and the Republic of Ireland Users

If you purchased your printer in the UK or the Republic of Ireland, EPSON (UK) LTD provides a range of customer services and technical support.

World Wide Web

If you can connect to the Internet and have a Web browser, you can access our Web site at <http://www.epson.co.uk>. Here you will find information on the latest EPSON products, software drivers, on-line user guides, and answers to frequently asked questions.

Faxon EPSON

Contact Faxon EPSON Faxback Service for support information including troubleshooting tips, switch settings, and driver information.

To use Faxon EPSON, call 01442 227332 in the UK or 0044 1442 227332 from the Republic of Ireland using a touch-tone phone. You will be asked to follow a simple routine to register your document request. Once you have entered your telephone and fax numbers, Faxon EPSON will fax a copy of the document catalogue to your fax machine.

When you have found the documents that you need in the catalogue, call Faxon EPSON again and enter the document ID numbers. The documents will be faxed to you automatically.

Bulletin Board Service for latest drivers and utilities

You can call the EPSON Bulletin Board Service on 01442 227479 in the UK or 0044 1442 227479 from the Republic of Ireland. No membership is required. Make sure that your communications software is set to 8 data bits, 1 stop bit, no parity bit, ANSI terminal mode emulation, and a modem speed of up to 28.8 Kbps. Downloading protocols supported include Xmodem, Ymodem, and Zmodem. See the documentation that came with your communications software and modem for more information.

When you first connect to the Bulletin Board Service, you will be asked for your name, company name, phone number, and a password (which you can invent yourself).

Customer and Warranty Support

Our Customer and Warranty Support teams can be contacted by calling 0870 163 7766 in the UK or 0044 0870 163 7766 from the Republic of Ireland. They can provide the following services.

- ❑ Technical information on installing, configuring, and operating your EPSON products
- ❑ Arranging for faulty EPSON products to be repaired within the warranty period

A full list of EPSON Customer and Warranty Support services is available on the technical support section of our world wide web pages at <http://www.epson.co.uk/support/> and on Faxon EPSON faxback service in document number 5085.

Pre Sales Enquiry Desk

The Enquiry Desk team can be contacted by calling 0800 220546 in the UK or 1 800 409132 from the Republic of Ireland, by faxing 01442 227271 in the UK or 0044 1442 227271 from the Republic of Ireland, and via Email at info@epson.co.uk. They can provide the following information.

- ❑ Pre Sales information and literature on new EPSON products (also available via our world wide web site at <http://www.epson.co.uk>)
- ❑ Where to purchase genuine EPSON consumables, accessories, and options

For Australian Users

EPSON Australia wishes to provide you with a high level of Customer Service. As well as this *User's Guide*, we provide the following sources for obtaining information.

EPSON FAXBACK

EPSON FAXBACK will fax you the latest specifications and pricing for most EPSON products offered in Australia. There is also technical information including details of the latest software and drivers available. Phone (02) 9903 9075 and the system will guide you through a number of choices before faxing the information to your fax machine.

EPSON Bulletin Board System

This is where you can download the latest software and drivers. Visit the BBS to check out the latest versions. If you have a modem, phone (02) 9417 5090.

Internet URL <http://www.epson.com.au>

Access the Epson Australia World Wide Web pages. Worth taking your modem here for the occasional surf! You can get the same information as offered on the EPSON FAXBACK and the EPSON Bulletin Board plus more.

Your dealer

Don't forget that your dealer can often help identify and resolve problems. The dealer should always be the first call for advice on problems. They can often solve problems quickly and easily as well as give you advice on the next step to take.

EPSON Helpdesk

EPSON Helpdesk is provided as a final backup to make sure our clients have access to advice. Operators on the Helpdesk can aid you in diagnosing hardware and software problems. They can also advise you on the latest EPSON products and where the nearest dealer or service agent is located. Many types of queries are answered here.

The Helpdesk numbers are:

Phone: (02) 9903 9040

Fax: (02) 9903 9189

We encourage you to have all the relevant information on hand when you ring. The more information you prepare, the faster we can help solve the problem. This information includes the *User's Guide* for your EPSON product, type of computer, operating system, application programs, and any other information you feel is required.

For Singapore Users

Contact the telephone and fax numbers below.

Phone: (065) 337-7911

Fax: (065) 334-1185

For Hong Kong Users

To obtain technical support as well as other after-sales services, users are welcome to contact EPSON Hong Kong Limited.

Internet home page

EPSON Hong Kong has established a local home page in both Chinese and English on the Internet to provide users with the following information.

- Product information
- Answers to Frequently Asked Questions (FAQs)
- Latest versions of EPSON camera software

Users can access our World Wide Web home page at:
<http://www.epson.com.hk>.

Electronic bulletin board system

An electronic bulletin board system (BBS) is also available to obtain camera information and the latest versions of camera software. You can log on to the following number for the BBS service.

BBS: (852) 2827-4244

Technical Support Hotline

You can also contact our technical staff at the following telephone and fax numbers.

Phone: (852) 2585-4399

Fax: (852) 2827-4383

For Philippines Users

To obtain technical support as well as other after sales services, users are welcome to contact the EPSON Philippines Representative Office at the telephone and fax numbers below.

Phone: (632) 813-6552

Fax: (632) 813-6545







BBS: (632) 814-0595

Dial Position Settings

The PhotoPC 800 has seven dial positions. This chapter shows the available settings in each dial position. Some dial positions have more than one screen. To change the screen, push or hold down the MENU button.

Dial switch positions



-  For taking multiple exposures.
-  For taking photos with the LCD monitor.
-  For taking pictures with the viewfinder.
-  For playing back and managing photos.
-  For using EPSON Photo!3 and Direct Print software.
-  For viewing information and setting up the camera.

Display panel

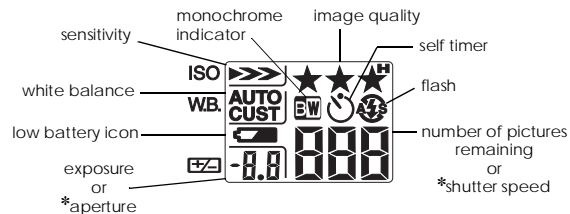

* When in the Program or Manual camera mode and shutter is pressed half-way.

Image quality settings



* Cannot be selected when using the continuous shooting feature.

Flash settings

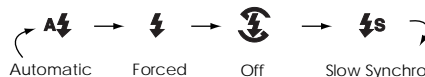

- When using continuous shooting, the flash is automatically set to **S**.
- When in the Full Auto camera mode, or when using the quick shooting function, Slow Synchro is disabled.

Available settings in the **i** dial position

Set date and time

Change camera mode

FullAuto, Program, or Manual

Choose Color or Monochrome

Choose Quick Shot or Normal Shot

Memory Setup

↓ Press the W.B. button to change screen

- Format
- Select directory
- Copy or delete programs

Set language

Choose between Japanese, English,
French, Dutch, Italian, Portuguese,
Spanish, or Chinese

Camera SETUP

↓ Press the MENU button to change screen

- Set automatic shut-off feature
10 seconds, 30 seconds, 1 minute, or 3 minutes
- Set LCD monitor's brightness
- Set white balance custom settings
- Set beep
Always, Never, or Shutter
- Audio recordings
3, 5, or 10 second recording, or off

Available settings in the dial position

Magnify photos

Erase/lock photos
All photos, selected photos

W.B. Erase individual photos

ISO Display multiple photos

MENU Hold down to change screen



Make audio recordings
Three, five, or ten seconds
Erase audio recording

View slide show
Change every 3, 5, or 10 seconds, or manually
Show all photos or selected photos

W.B. View photo information

MENU Display multiple photos

Available settings in the dial position

When using the Program camera mode

x1/x2 Turn digital zoom on/off

+/- Adjust exposure setting
From -2.0 to +2.0 by increments of 0.5

Choose frame
Normal,  Macro, or  Panorama

W.B. Choose white balance
AUTO, FIX, or CUSTOM

ISO Choose sensitivity
Standard, High, or Super High

MENU Hold down to change screen



x1/x2 Turn digital zoom on/off

Choose Program camera mode setting
Normal, Sports, Portrait, or Landscape

When using the Manual camera mode

x1/x2 Turn digital zoom on/off

+/- Choose exposure adjustment
From -2.0 to +2.0 by increments of 0.2

Choose frame
Normal,  Macro, or  Panorama



ISO Change exposure
AUTO or MANUAL



MANUAL settings

- Shutter Speed
AE, or 1/2 to 1/750 seconds by
increments of 64
- Aperture
f2.4 or f8

MENU Hold down to change screen

x1/x2 Turn digital zoom on/off

+/- Choose focus settings
For Normal or Panorama frame
AF (auto focus),  (about 1 m),
 (about 3 m), or  (more than 3 m)
For Macro frame
AF (auto focus), or 1 (about 15 cm)
to 10 (about 50 cm)

Choose metering system
 divided brightness metering
system, or  spot metering system

W.B. Choose white balance
AUTO, FIX, or CUSTOM

ISO Choose sensitivity setting
Standard, High, or Super High

Glossary

application

A software program that helps you carry out a particular task, such as word processing, image editing, or financial planning.

bit

Short for binary digit. The smallest unit of data in computer processing. A bit can represent two values: on and off, or 1 and 0.

browser (Web browser)

An application which allows the users to view HTML documents.

default

A value or setting that takes effect when the equipment is turned on, reset, or initialized. Also known as a factory setting.

Design rule for camera file system

Recording standard for image files. Established by Japan Electronic Industry Development Association (JEIDA).

Exif2.1

Standard format for audio/image files. Established by Japan Electronic Industry Development Association (JEIDA).

exposure

The amount of light the camera captures when a photo is taken.

Image

Data representing a two-dimensional scene. A digital image is composed of pixels arranged in a rectangular array with a certain height and width. Each pixel may consist of one or more bits of information, representing the brightness of the image at that point.

ink jet printer

A printer that transfers ink onto paper by spraying the ink through a number of small nozzles.

interface

A piece of hardware, a method, or a standard used for connection between the computer and the camera.

macro

An enlargement or a close-up of an image.

NTSC

National Television Standards Committee. A video encoding standard largely used in North America and Japan.

PAL

Phase Alternation Line. A video encoding standard largely used in Europe and Australia.

pixel

Short for picture element. Each image is composed of a number of pixels. Pixels are also counted in units of dots.

port

An interface channel through which data is transmitted between devices.

resolution

Indication of how finely an image is resolved into pixels. See *pixel*.

thumbnails

Small representations of images.

white balance

The balance between the whiteness and color in your image. When the white balance is fixed to the environment where the picture is taken, the colors in your images appear more like those seen by the eye.

zoom

To show a smaller area of an image at a higher magnification (zoom in) or a larger area at a lower magnification (zoom out).

Index

A

- AC adapter, 2
 - connector, 1-2
 - specifications, A-7
 - using, 5-6 to 5-7
- AC power cord, 1-1
- Activating the shutter, 2-5, 2-11
- Aperture setting, 2-18
- Attaching the hand strap, 1-9
- Audio recordings, 2-2, 2-3, 2-22 to 2-23, 2-26, 3-1, 3-8, 5-2, 5-3
- Automatic shut-off feature, 2-26 to 2-27

B

- Batteries
 - charging, 1-4 to 1-5
 - checking, 1-6, 1-7
 - disposing of, 1-8
 - handling, 1-7
 - icon, 1-3
 - installing, 1-6
 - replacing, 1-7
 - specifications, A-5
 - storing, 1-8
- Battery charger, 2, 1-1
 - cleaning, 6-2
 - specifications, A-5
 - using, 1-4 to 1-5
- Beep, 2-5, 2-11, 2-27

- Brightness, LCD monitor, 2-27
- Buttons, 1-2 to 1-3

C

- Cables
 - for direct printing, 4-2
 - Macintosh serial, 1-1
 - USB, 1-1
 - video, 1-1
 - Windows serial, 1-1
- Camera
 - buttons, 1-2 to 1-3
 - cleaning, 6-2
 - handling, 6-1
 - parts, 1-1
 - physical dimensions, A-1
 - problems, 2-2, 6-3 to 6-6
 - storing, 6-2
- Camera modes, 2-24 to 2-25
 - changing, 2-25
 - Full Auto, 2-9, 2-10, 2-24, C-1
 - Manual, 1-3, 2-9, 2-14, 2-25, C-1, C-4
 - Program, 1-3, 2-9, 2-14, 2-25, C-1, C-3
- Checking
 - batteries, 1-6, 1-7
 - picture counter, 2-2, 6-3, 6-6

Cleaning

battery charger, 6-2

camera, 6-2

Color/monochrome setting, 2-25

Color Guide, 2-29

CompactFlash Card, 2-29

copying photos, 5-3

copying programs, 5-4

formatting, 5-5

installing, 1-9 to 1-10

installing into the computer, 5-2

removing, 1-10

selecting folder, 2-29

specifications, A-6

storage capacity, 5-1

Continuous shooting, 2-20

Copying photos, 5-3

Copying programs, 5-4

Covers

battery, 1-3

lens, 1-2

memory card, 1-3

Customer support, B-1 to B-5

D

Date and time setting, 1-11

Dial switch, 1-2

available settings, C-2 to C-4

LCD monitor, 2-10 to 2-19, C-3

positions, C-1

viewfinder, 2-4 to 2-10

Dial switch lock, 1-2

Digital zoom, 2-11

Direct Print

accessing the program, 4-5

connecting the camera to the computer, 4-4

connecting the camera to the printer, 4-3

deleting the program, 4-5, 5-4

installing the program, 4-4 to 4-5

printed image dimensions, 4-13

printing procedures, 4-8 to 4-10

status messages, 4-11 to 4-12

supported paper types, 4-2

supported printers, 4-2

Display panel, 1-2

camera, icons, 1-3

printer, messages, 4-12

Disposing of batteries, 1-8

E

EPSON Photo File Format, 3-1

Erasing

all the photos, 3-6

audio recordings, 3-8

individual photos, 3-5

selected photos, 3-6

Exposure setting, 2-10, 2-13 to 2-14, 2-16 to 2-18

F

Flash, 1-2

range, A-3

settings, 2-8

Formatting memory cards, 5-5

Full Auto camera mode, 2-9, 2-10, 2-24, C-1

H

- Hand strap, 1-1
 - attaching, 1-9
 - holder, 1-2

I

- Icons
 - divided brightness metering system, 2-19
 - flash, 1-3
 - low battery, 1-3, 1-6
 - self timer, 1-3
 - sensitivity, 1-3
 - spot metering system, 2-19
- Image quality setting, 2-7 to 2-8
- Installing
 - batteries, 1-6
 - CompactFlash Card, 1-9 to 1-10
- Interface connector, 1-2
- Interface specifications, A-4

L

- Languages, 1-10, 2-28
- LCD monitor, 1-2, 2-27
 - messages, 4-11 to 4-12
- Lens, 1-2
- Lens cover switch, 1-2
- Lights
 - shooting, 1-2, 2-4, 2-5, 6-3
 - status, 1-2, 2-5, 2-11, 4-10
 - timer, 1-2, 2-6

Lock

- battery cover, 1-3
 - dial switch, 1-3
 - memory card cover, 1-3
- Locking photos, 3-7 to 3-8

M

- Macro function, 2-12
- Maintenance, 6-1 to 6-2
- Manual camera mode, 1-3, 2-9, 2-14, 2-25, C-1, C-4
- Manual focus setting, 2-18
- Memory card
 - See CompactFlash Card
- Messages
 - camera's LCD monitor, 4-11 to 4-12
 - printer's display panel, 4-12
- Metering system setting, 2-19
- Microphone, 1-2
- Monochrome/color setting, 2-25
- Multi-photo playback, 3-1 to 3-2

N

- Ni-MH rechargeable batteries, 2, 1-1

O

- Optical specifications, A-3
- Options, 2 to 3
 - AC adapter, 5-6 to 5-7, A-7
 - PCMCIA adapter, 5-2, A-6

P

- Panoramas, 2-12
- PCMCIA adapter, 2
 - specifications, A-6
 - using, 5-2
- Photographs
 - See Pictures
- Photo information, 3-1, 3-5
- Photo processing time, A-4
- Physical dimensions, A-1
- Picture counter, 2-2
- Pictures
 - close-ups, 2-12
 - copying, 5-3
 - erasing, 3-5 to 3-7
 - locking, 3-7 to 3-8
 - printing using the Direct Print program, 4-1 to 4-10
 - problems, 6-7 to 6-9
 - processing time, A-4
 - recorded image specifications, A-2
 - shooting range, 2-1
 - storage capacity, 2-7
 - taking, 2-4 to 2-5, 2-10 to 2-11
 - unlocking, 3-7 to 3-8
- Playing back photos
 - multiple photos at once, 3-1 to 3-2
 - on a projector, 3-11
 - on a television, 3-10 to 3-11
 - on the LCD monitor, 3-1 to 3-5
 - using the magnification function, 3-2

- Power specifications, A-4
- Printed image dimensions, 4-13
- Printer's display panel messages, 4-12
- Printing pictures, 4-1 to 4-13
- Problems
 - camera, 2-2, 6-3 to 6-6
 - picture, 6-7 to 6-9
- Program camera mode, 1-3, 2-9, 2-14, 2-25, C-1, C-3

Q

- Quick shooting function, 2-26

R

- Rechargeable batteries, 2, 1-1
- Removing CompactFlash Card, 1-10
- Replacing batteries, 1-7
- Rotating pictures
 - printing, 4-7, 4-9
 - slide show, 3-4

S

- Safety instructions
 - when using the camera, 3 to 4
 - when using the charger and batteries, 4 to 6
 - when using the hand strap, 4
- Self timer, 2-6
 - light, 1-2
- Sensitivity setting, 2-9, 2-15

Settings

- aperture, 2-18
 - automatic shut-off feature, 2-26 to 2-27
 - available in Full Auto camera mode, 2-9, 2-10, 2-24, C-1
 - available in Manual camera mode, 1-3, 2-9, 2-14, 2-25, C-1, C-4
 - available in Program camera mode, 1-3, 2-9, 2-14, 2-25, C-1, C-3
 - beep, 2-27
 - color/monochrome, 2-25
 - date and time, 1-11
 - exposure, 2-13 to 2-14, 2-16 to 2-18
 - exposure setting, 2-10
 - flash, 2-8
 - image quality, 2-7 to 2-8
 - language, 1-10, 2-28
 - LCD monitor brightness, 2-27
 - manual focus, 2-18
 - metering system, 2-19
 - sensitivity, 2-9, 2-15
 - shutter speed, 2-17
 - time and date, 2-24
 - white balance, 2-9, 2-14 to 2-15
- Shooting light, 1-2, 2-4, 2-5, 6-3
- Shut-off feature, 2-26 to 2-27
- Shutter button
- location, 1-2
 - using, 2-5, 2-11
- Shutter speed setting, 2-17
- Slide show, 3-3 to 3-4

Specifications

- AC adapter, A-7
- battery, A-5
- battery charger, A-5
- camera, A-1 to A-5
- CompactFlash Card, A-6
- optical, A-3
- PCMCIA adapter, A-6
- Status light, 1-2, 2-5, 2-11, 4-10
- Status messages for direct printing, 4-11 to 4-12
- Storage capacity
 - camera, A-1
 - CompactFlash Card, 5-1
- Storing
 - the batteries, 1-8
 - the camera, 6-2

T

- Taking panoramas, 2-12
- Taking pictures, 2-4 to 2-5, 2-10 to 2-11
 - continuously, 2-20
 - using macro function, 2-12
 - using quick shooting function, 2-26
 - using self timer, 2-6
 - using time lapse function, 2-21
 - using zoom function, 2-11
- Time and date setting, 2-24
- Time lapse function, 2-21
- Timer light, 1-2
- Tripod socket, 1-3
- Troubleshooting, 6-3 to 6-9

U

Unlocking photos, 3-7 to 3-8

Unpacking your camera, 1-1

V

Video out connector, 1-2

Viewfinder, 1-2

 using, 2-4 to 2-6

Viewing slide show, 3-3

W

White balance setting, 2-9, 2-14 to 2-15

EPSON OVERSEAS MARKETING LOCATIONS

EPSON AMERICA, INC.

20770 Madrona Ave.
P.O. Box 2842
Torrance, CA 90509-2842
Phone: (800) 922-8911
Fax: (310) 782-5220

EPSON UK LTD.

Campus 100, Maylands Avenue,
Hemel Hempstead, Herts,
HP2 7TJ, U.K.
Phone: (+44) 01442 261144
Fax: (+44) 01442 227227

EPSON DEUTSCHLAND GmbH

Zuppicher StraÙe 6,
40549 Düsselndorf Germany
Phone: (0211) 56030
Fax: (0211) 5047787

EPSON FRANCE S.A.

68 bis, rue Marjolin
92300, Levallois-Perret, France
Phone: 33.1.40.87.37.37
Telex: 610657

**EPSON AUSTRALIA PTY.
LTD.**

70 GIBBES STREET,
CHATSWOOD 2067 NSW.
Phone: 2-9903-9000
Fax: 2-9903-9177

EPSON SINGAPORE PTE. LTD.

No. 1 Temasek Avenue #36-00
Millenia Tower, Singapore 039192
Phone: (065) 33 77 911
Fax: (065) 33 41 185

EPSON HONG KONG LTD.

Rooms 4706-10, 47/F,
China Resources Bldg.,
26 Harbour Road, Wanchai,
Hong Kong
Phone: 2585-4300
Fax: 2827-7083

**EPSON TAIWAN TECHNOLOGY &
TRADING LTD.**

10F, No. 287 Nanking E. Road, Sec. 3,
Taipei, Taiwan, R.O.C.
Phone: (02) 717-7360
Fax: (02) 712-9164

EPSON ITALIA S.p.A.

V.le F.lli Casiraghi 427
20099 Sesto S.Giovanni
MI, Italy
Phone: 2-262331
Fax: 2-2440750

EPSON IBERICA S.A.

Av. de Roma, 18-26
08290 Cerdanyola del Valles
Barcelona, Spain
Phone: 582. 15.00
Fax: 582. 15.55

EPSON PORTUGAL, S.A.

R. do Progresso, 471, 1^o Perafita
4460 Matosinhos, Portugal
Phone: (02) 996 14 02
Fax: (02) 996 14 11

**SEIKO EPSON CORPORATION
(Hirooka Office)**

80 Harashinden, Hirooka
Shiojiri-shi, Nagano-ken
399-0785 Japan

EPSON

Color Digital Camera



PhotoPC₈₀₀
User's Guide