



Multimedia Storage Viewer™ **P-6000**

Multimedia Storage Viewer™ **P-7000**

Basic Operation Guide

EPSON® is a registered trademark of Seiko Epson Corporation.

Photo Fine and its logo are registered trademarks or trademarks of Seiko Epson Corporation in Japan and other countries. Photo Fine Premia is a proprietary technology of Epson Imaging Devices Corporation.

Microsoft®, Windows®, and Windows Vista® are registered trademarks of Microsoft Corporation in the United States and/or other countries.

Apple® and Macintosh® are registered trademarks of Apple Inc.

SD™ is a trademark.

QuickTime and the QuickTime logo are trademarks or registered trademarks of Apple Inc., used under license.

This product is licensed under the MPEG-4 Visual Patent Portfolio License for the personal and non-commercial use of a consumer for (i) encoding video in compliance with the MPEG-4 visual standard (MPEG-4 Video) and/or (ii) decoding MPEG-4 Video that was encoded by a consumer engaged in a personal and non-commercial activity and/or was obtained from a video provider licensed by MPEG LA to provide MPEG-4 Video. No license is granted or shall be implied for any other use. Additional information including that relating to promotional, internal and commercial uses and licensing may be obtained from MPEG LA, L.L.C. - see <www.mpegla.com>

MPEG Layer-3 audio coding technology is licensed from Fraunhofer IIS and Thomson.

This product is licensed under the AVC Patent Portfolio License for the personal and non-commercial use of a consumer to (i) encode video in compliance with the AVC standard (AVC Video) and/or (ii) decode AVC Video that was encoded by a consumer engaged in a personal and non-commercial activity and/or was obtained from a video provider licensed to provide AVC Video. No license is granted or shall be implied for any other use. Additional information may be obtained from MPEG LA, L.L.C. - see <www.mpegla.com>

Adobe®, Adobe® Photoshop®, and Adobe® RGB are registered trademarks of Adobe Systems Incorporated in the United States and/or other countries.

General Notice: Other product names used herein are for identification purposes only and may be trademarks of their respective owners. Epson disclaims any and all rights in those marks.

Copyright © 2008 Seiko Epson Corporation. All rights reserved.

Contents

Chapter 1 Getting Started

Unpacking the Viewer	5
Parts	5
Control Panel	6
Setting Up the Viewer	7
Charging the battery	7
Turning the power on/off	8
Preventing key operations	8
Initial settings	8
Home screen	10
Installing the Software	11
Computer system requirements	11
How to install	11

Chapter 2 Transferring Data to the Viewer

Transferring from CF/SD Memory Cards	14
Transferring from a Digital Camera	15
Connecting a digital camera	15
Copying data	16

Chapter 3 Viewing Images

Viewing Photos and Videos	17
---------------------------------	----

Displaying the contents screen	18
Displaying information	18
Zooming a photo	18
Basic operations while playing videos	19
Managing Files and Folders	19
Copying/Moving files and folders	19
Deleting files and folders	20
Protecting files and folders	20
Using ratings to filter your photos	21

Chapter 4 Backing Up Data from the Viewer

Transferring to USB Storage Devices	22
Transferring to the Computer	22

Chapter 5 Creating Custom Print

Using the Print Wizard Menu	24
-----------------------------------	----

Chapter 6 Other Features

Problems and Solutions28
Resetting the Viewer29
Formatting Data in the Viewer29

Safety instructions

Warnings, Cautions, and Notes



Warnings

must be followed carefully to avoid bodily injury.



Cautions

must be observed to avoid damage to your equipment.

Notes

contain important information and useful tips on the operation of the viewer.

When using the viewer



Caution:

- Do not expose the viewer to any impact, doing so may cause malfunctions.*

- Do NOT format the viewer's hard disk drive from your computer, as this will render the viewer inoperable. If this happens, test the format by following the procedure in "Formatting Data in the Viewer" on page 29. If this does not fix the problem, you should contact an authorized Epson service center. Repairs will be chargeable and are not covered by Epson's warranties.*

- Do not drop or apply any shock to the viewer. Take care when carrying it, as strong shocks may damage the internal hard disk drive and cause data to be lost.*

- Epson is not responsible for backing up or recovering data. We strongly recommend that you make your own backup files.*

Note:

For other cautions and more information about using the viewer, see the User's Guide.

Chapter 1

Getting Started

Unpacking the Viewer

Make sure that all of the items shown below are included in the box.

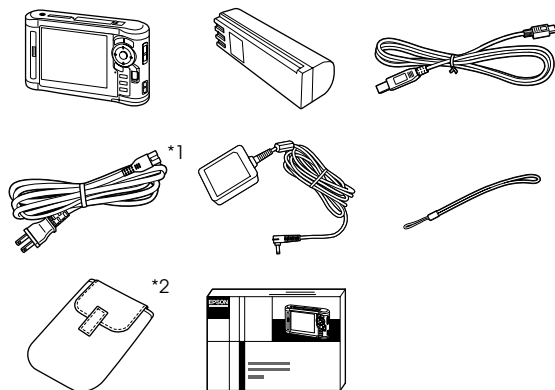

*1 The plug type for the power cable may vary depending on the local standards.

*2 The included items may vary depending on the region and model.



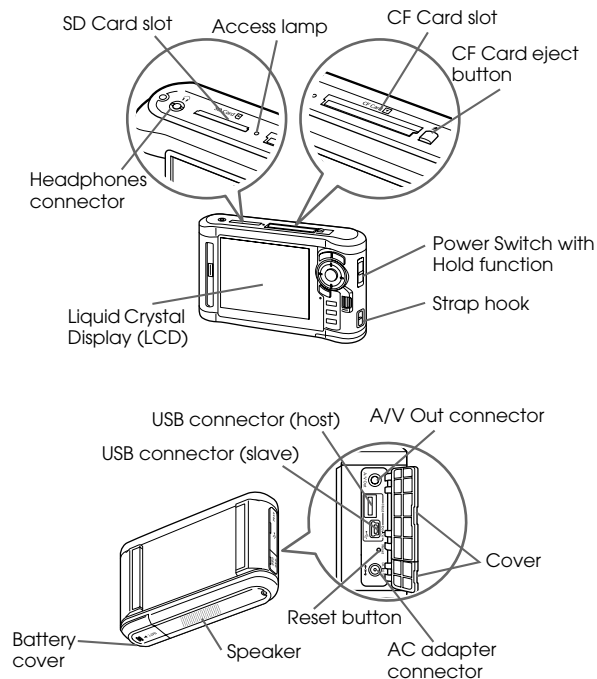



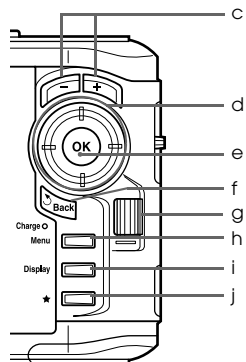
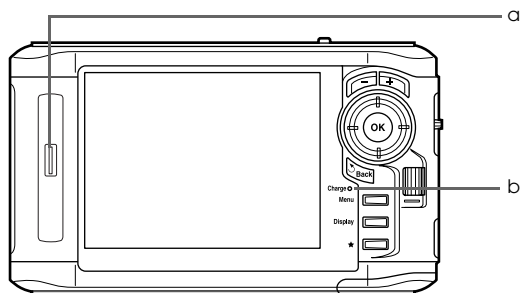



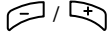



Parts



Control Panel



Lamps		
a	Illumination lamp (Blue)	Flashes during operations such as turning the power on, printing, LCD power-off mode, and so on.
b	Charge lamp	Lit green during battery charging. Lit orange when an error has occurred.

Keys		
c	 key	Press to zoom a photo, and adjust the volume.
d	4-way ring ( /  /  / )	Press to move the cursor or highlight. You can select an item by pressing up, down, left, or right.
e	 key	Press to complete the selection and proceed to the next step.
f	 key	Press to cancel the selection and return to the previous screen.
g	Wheel key	Roll to move the cursor or highlight. You can select items quickly by rolling this key. This operates in a similar way to the  ,  ,  , and  keys.
h	 key	Press to display the pop up menu.
i	 key	Press to switch the screen.
j	 key	Press to rate a particular photo and determine the selection. For details, see "Using ratings to filter your photos" on page 21.

Setting Up the Viewer

Charging the battery

1. Open the battery cover.



2. Insert the battery into the compartment in the direction of the arrow on the battery sticker.

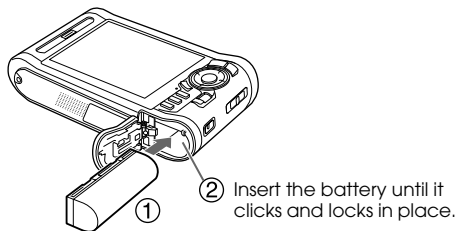

3. Close the battery cover and slide it to the left until it clicks.

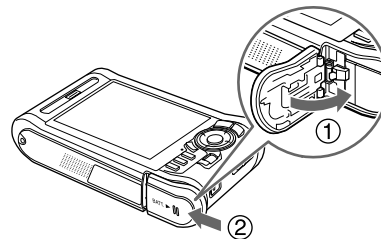

4. Connect the AC adapter, then plug the other end into a power outlet.

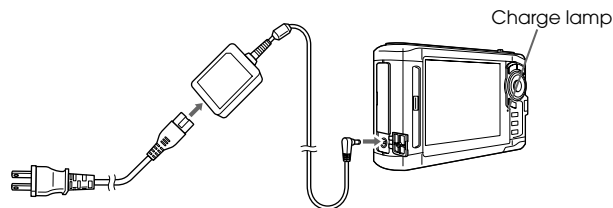

The Charge lamp lights green during charging. It takes about 3.5 hours to fully charge the battery when the power is off.



Caution:

- ❑ Disconnect the AC adapter before removing the battery.
- ❑ Do not connect the AC adapter when the battery is not installed. Doing so may cause damage to the viewer.
- ❑ If the Charge lamp lights orange, see "Troubleshooting" on page 28.

Turning the power on/off

Make sure the battery is inserted.

Slide the power switch to I/⏻. The Illumination lamp turns on.

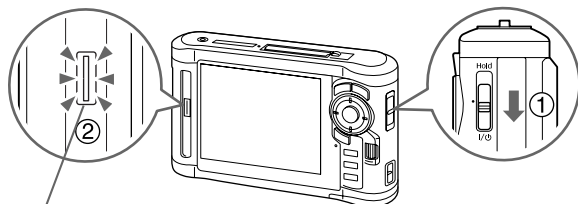

Illumination lamp

To turn the power off, slide the power switch to I/⏻ and hold down until the shut down display appears.

Preventing key operations

Slide the power switch to Hold.

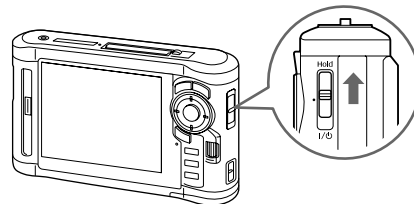

To release Hold, slide the power switch back to the middle.

Initial settings

When you turn on the viewer for the first time, the setting screen appears.

Set the language, date, and time.

1. Select the language to use with \blacktriangle / \blacktriangledown , and then press $\textcircled{\text{OK}}$.



2. After the message saying “Set current Date and Time.” appears, press $\textcircled{\text{OK}}$ to proceed.
3. Set the date and time using the \blacktriangle / \blacktriangledown / \blacktriangleleft / \blacktriangleright .

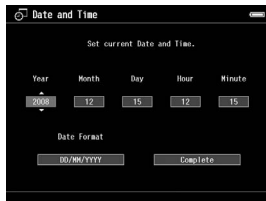

4. After you finish all settings, select Complete using \blacktriangleleft / \blacktriangleright , and then press $\textcircled{\text{OK}}$.









Note:





If approximately 24 hours passes after removing the battery, the date and time settings may be lost, and will need to be set again.



Home screen



The following tables show the icon menu of the Home screen.

 (Battery)	 :Indicates sufficient battery power.  :Indicates moderate battery power.  :Indicates low battery power.  :Indicates the viewer is charging.
 (CF)	Indicates the CF memory card is set (page 14).
 (SD)	Indicates the SD memory card is set (page 14).
 (Hold)	Indicates the key operations are on hold (page 8).

 (Backup Files)	Select to display files/folders backed up from CF/SD memory cards.
 (My Photos)	Select to display files/folders stored in the Photos folder.
 (My Videos)	Select to display files/folders stored in the Videos folder.
 (My Music)	Select to listen to music transferred from the computer.
 (Memory Card)	Select to display files on CF/SD memory cards or store memory card data onto the viewer.

 (USB Device)	Select to transfer data between a USB device and the viewer or to use the USB Display Plug-In.
 (Settings)	Select to set the viewer's various settings.
 (Print Wizard)	Select to follow procedures to complete work on your photos and print. You can edit, crop, layout, and print your photos.

Installing the Software

The viewer uses the following specified software.

Epson Link2	You can transfer data from the computer to the viewer easily.
USB Display Plug-In	You can display images from Adobe Photoshop products on the viewer and edit photos while confirming a faithful color representation.
Quick Time	

Computer system requirements

Hard disk	1 GB or more free space is required for operation
OS	Microsoft® Windows® Vista Home Basic Edition, Vista Home Premium Edition, Vista Business Edition, Vista Enterprise Edition, Vista Ultimate Edition, 2000 Professional, XP Home Edition, XP Professional, Millennium Edition Mac OS X 10.3 or later

Note:

To install USB Display Plug-In, at least one of the following products must be installed on the computer beforehand. *Photoshop CS**, *Photoshop CS2*, *Photoshop CS3*, *Photoshop Elements 4.0*, *Photoshop Elements 5.0**, *Photoshop Elements 6.0**.

* Windows only

How to install

Connect the viewer to the computer, then install the necessary software. For details about computer connection, see "Transferring to the Computer" on page 22.

Note:

- Do not delete the installer (EXE/DMG file) on the viewer's hard disk.

- ❑ *We recommend backing up the installer onto your computer.*
- ❑ *You need administrative privileges to install the software.*

For Windows users

1. Connect the viewer to the computer.
2. Click Start, select My Computer (or Computer), then double-click the viewer's hard disk drive icon.
3. Copy the P_XXXX_WIN_SOFTWARE icon to your computer.

Note:

P_XXXX is the model name of your viewer.

4. Double-click the P_XXXX_WIN_SOFTWARE icon.
 5. Select Desktop as the destination for the decompressed files, and then click Yes.
- Note:**
For Windows Vista, when the User Account Control window appears, click Continue.
6. On the software installation screen, click Easy Install.

Note:

If you are prompted to select a language, select your preferred language.

7. When the software license agreement screen appears, read the statement and then click Agree.
8. Select your country, and then follow the on-screen instructions.
9. When a message appears indicating that installation is complete, click Exit or Restart Now.

Note:

When Restart Now appears, click the button to restart your computer.

For Macintosh users

1. Connect the viewer to the computer.
2. Double-click the viewer's hard disk icon on the desktop.
3. Copy P_XXXX_MAC_SOFTWARE.DMG to your computer.

Note:

P_XXXX is your viewer's model name.

4. Double-click P_XXXX_MAC_SOFTWARE.DMG.
5. Double-click the Mac OS X icon.
6. On the software installation screen, click Easy Install.

Note:

If you are prompted to select a language, select your preferred language.

7. When the software license agreement screen appears, read the statement and then click Agree.
8. Select your country, and then follow the on-screen instructions.

If the Authenticate window appears, click the key icon, enter the administrator's name and password, and then click OK.

9. When a message appears indicating that installation is complete, click Exit or Restart Now.

Note:

When Restart Now appears, click the button to restart your computer.

Transferring Data to the Viewer

You can transfer data taken with a digital camera to the viewer.



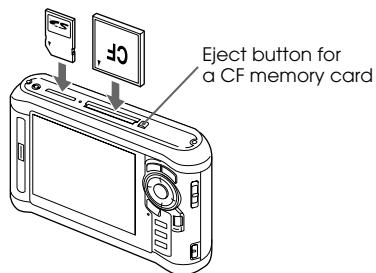

Transferring from CF/SD Memory Cards

1. Insert the memory cards with the label side facing the display side of the viewer.





Note:

- ❑ According to the screen that appears when inserting the memory card, skip step 2.

- ❑ You can keep both a CF memory card and an SD memory card loaded in their respective slots simultaneously.
 - ❑ Be sure to use the viewer with the eject button pushed in to avoid possible damage.
2. Select  Memory Card on the Home screen using  / , and then press .

Note:

According to the screen that appears when inserting the memory card, skip step 2.

3. On the Memory Card screen, select CF Memory Card Backup or SD Memory Card Backup using  / .
4. Press  to start copying.

After copying is complete, backup data is displayed automatically.

5. Make sure that the Access lamp is off before removing the memory cards.
6. For a CF memory card, push the eject button twice. For an SD memory card, push the memory card down slightly then release, and it will pop up for you to remove completely.

Note:

- Before copying data, charge the battery fully. If the battery is low, connect the AC adapter. The transfer is canceled if the viewer's power supply is disconnected during transfer.
- 1 GB of data may take approximately 2 minutes or more to copy, depending on the memory card you use.

Supported memory card types

CF (CompactFlash) memory card (Type2 and 3.3 V, including Micro Drive)
SD memory card (up to 2 GB), SD High-Capacity card
MultiMedia Card, MultiMedia Card Plus

Commercially available adapters are required to use other memory cards (miniSD, microSD, RS-MMC, Memory Stick Duo, Memory Stick PRO Duo, xD-Picture Card, and so on). Contact our customer support for details.

Transferring from a Digital Camera

You can transfer data to the viewer directly from digital cameras that support the USB Mass Storage specification.

Connecting a digital camera

1. Connect the AC adapter to the viewer.

Note:

When the remaining battery is low on your digital camera, connect the AC adapter.

2. Open the upper side cover of the viewer and connect a USB cable to the Host (Standard-A) connector. Then connect the other end to your digital camera.
3. Turn on the viewer and your digital camera.













Note:

- Use the USB cable supplied with your camera to connect.
- Do not connect to both of the viewer's USB interfaces (Host-Standard A and Slave-Mini B) at the same time. It may cause a malfunction.

- ❑ *Do not touch the Slave-Mini B connector interface during USB data transfer.*

Copying data

You can transfer all of the data on a digital camera to the viewer in a single operation.

1. Select  USB Device on the Home screen using  / , and then press .
2. Select Connect to USB Device on the USB screen using  / , and then press .
3. If you want to transfer all the data, select Backup USB device to Viewer using  / , then press . If you want to select and copy specific data, select Browse USB device using  / , and then press .

Note:



- ❑ *Connecting a digital camera through the USB hub is not supported.*
- ❑ *Transfer time varies depending on your digital camera, but generally, 1 GB of data will take approximately 3 minutes.*

Chapter 3

Viewing Images

You can view and edit images on the viewer.

Viewing Photos and Videos

1. Select  Backup Files,  My Photos, or  My Videos on the Home screen using \blacktriangle / \blacktriangledown / \blacktriangleleft / \blacktriangleright , and then press \blacktriangleright .

Note:

- ❑ Press the \blacktriangleright to display the subfolders in the folder. You can easily navigate the folder structure when a subfolder is displayed on the right by selecting a folder with the \blacktriangle / \blacktriangledown and then pressing the \blacktriangleright . Nothing is displayed on the right when the folder does not contain any subfolders.
- ❑ You can transfer data from the computer to My Photos or My Videos using the Epson Link2 software. You can copy from Backup Files on the viewer. For details, see “Copying/Moving files and folders” on page 19.

2. Select a folder to view using \blacktriangle / \blacktriangledown / \blacktriangleleft / \blacktriangleright , and then press OK .

3. Select a file to view using \blacktriangle / \blacktriangledown / \blacktriangleleft / \blacktriangleright , and then press OK to playback.

Note:

When viewing photos, pressing \blacktriangleright displays the next image and pressing \blacktriangleleft displays the previous image.

Supported photo/video file formats

File	Format
Photo	JPEG, RAW
Video	MPEG4, H.264/AVC, MJPEG

Note:

For details on the supported file formats, see the User’s Guide.

Displaying the contents screen

You can change the way files and folders are displayed by pressing **[Display]**. When you press **[Display]**, the display changes in the order of 12 thumbnails, 64 thumbnails, and a detailed list.

Setting information for files and folders is displayed by icons.

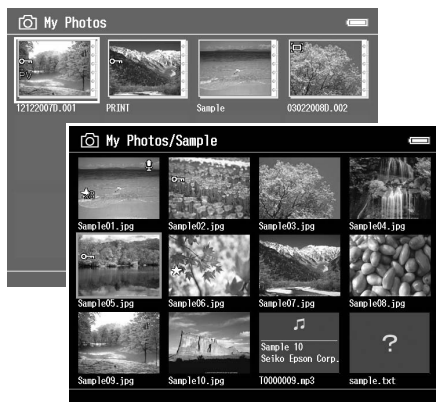

	Locked file / folder		Music format file
	Unsupported data		Private folder

	Rating information		Folder set as screen saver
	Still image with a sound memo attached		

Note:

For details about the screen icon, see the User's Guide.

Displaying information

When viewing a photo or video, press **[Display]** to display its information.

For photo files, press **[Display]** once at a time to display Basic Information, Exif Information with histograms, or Over-under exposure preview.

For video files, the progress information is displayed at first. You can switch to the file information (as below) by pressing **[Display]** again.

Zooming a photo

Press **[+]** to zoom in on a photo displayed in full screen. Continue pressing it to zoom in even further. You can move around the zoomed photo using the **▲/▼/◀/▶**.

Basic operations while playing videos

Key	Function
Ⓞ	Play/Pause
⏮*	Stops the video and returns to the previous screen.
⏪ / ⏩	Adjusts the volume.
⏮ / ⏩	Rewind/Fast-forward**

* When you press ⏮ to stop playback, the viewer remembers the resume point for the next time you start playback. The next time you start playback, playback starts from 3 seconds before the resume point. If you want to play back the video from the beginning, press [Menu], select Play Settings (if displayed), Play from Beginning, and then press Ⓞ. This function cannot be used for a video with a total playback time of 1 minute or less. (Resume does not work for some video files.)

** Rewind and fast-forward speeds increase if you press ⏮/⏩ several times while rewinding/fast-forwarding. (Rewind/Fast-Forward does not work for some video files.)

- Press [Menu] to display the pop up menu, select Copy/Move using ▲ / ▼, and then press Ⓞ or ▶.
- Select Select and Copy Files or Select and Move Files using ▲ / ▼, and then press Ⓞ.

Note:

When selecting only one file to copy or move, select Copy this File or Move this File.



- Use the ▲ / ▼ / ⏮ / ⏩ and ★ to select the check boxes of files or folders to copy or move, and then press Ⓞ to complete.



Managing Files and Folders

Copying/Moving files and folders

- Highlight a file or folder to copy or move.

5. Select a folder to copy or move to using the \blacktriangle / \blacktriangledown / \blacktriangleleft / \blacktriangleright , and then press \odot .

Deleting files and folders

1. Highlight a file or folder to delete.
2. Press Menu to display the pop up menu, select Delete using \blacktriangle / \blacktriangledown , and then press \odot .
3. Use the \blacktriangle / \blacktriangledown / \blacktriangleleft / \blacktriangleright and \star to select the check boxes of files or folders to delete, and then press \odot to complete.



4. After the confirmation dialog box appears, select Yes using \blacktriangle / \blacktriangledown , and then press \odot to complete.

Protecting files and folders

You can lock the selected file or folder. When a file or folder is locked, the key icon is displayed and it cannot be deleted or rotated.

1. Highlight a file or folder to lock.
2. Press Menu to display the pop up menu, select Edit using \blacktriangle / \blacktriangledown , and then press \odot or \blacktriangleright .
3. Select Lock/Unlock using \blacktriangle / \blacktriangledown , and then press \odot .



4. Use the \blacktriangle / \blacktriangledown / \blacktriangleleft / \blacktriangleright and \star to select the check boxes of files or folders to lock, and then press \odot to complete. (Files or folders which have already been locked are displayed with check marks. Pressing \star removes the check mark and unlocks the file or folder.)

Note:

The lock on the file or folder remains in effect until you unlock it, even if you turn off the viewer.

- ❑ To edit a file that you rated with the viewer using Adobe Bridge, see the online *Epson Link2 User's Guide*.

Using ratings to filter your photos

When photos have ratings attached, you can filter them for display according to the number of stars. Press **[Menu]** during thumbnail or list display, and then use the Rating filter to select the star rating of the photos you want to display. To attach a rating to a photo, use the following procedure.

After selecting a photo file, press **★**. You can rate photos from one to five stars.

Note:

- ❑ You can only rate JPEG and RAW image files.
- ❑ You cannot rate data stored on a USB device or memory card.
- ❑ When a photo file is rated five stars, pressing **★** deletes its rating.
- ❑ Folders are always displayed after filtering.
- ❑ Files other than JPEG and RAW are not displayed after filtering.

Backing Up Data from the Viewer

You can transfer data from the viewer to the computer. Be sure to back up important data.

Transferring to USB Storage Devices

You can transfer data to other USB devices. For details, see the User's Guide.

You can use the following USB storage devices that are capable of copying: external HDD drives, CD/DVD drives, USB memories, card reader/writers, and Epson Multimedia Storage Viewers.

Transferring to the Computer

Before transferring, install the Epson Link2 software.

1. Connect the AC adapter.
2. Turn on the viewer and the computer.

3. Open the USB connector's cover and connect the USB cable to the viewer. Then connect the other end of the USB cable to the computer.

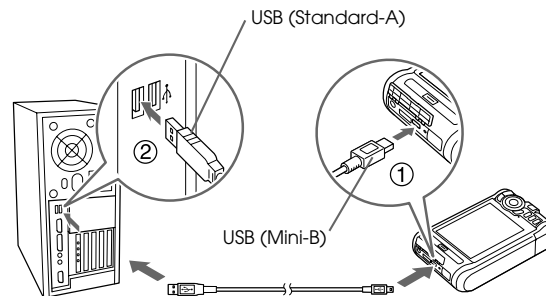

4. Press ★ on the Home screen.

Note:

You can also connect by selecting USB Device.

5. When the connection to the computer is complete, the LCD display turns off.

Note:

- ❑ *When the viewer is connected to a computer, do not connect a USB device to the Host-standard A, or touch the connector interface.*
- ❑ *After connecting the viewer to the computer, the LCD turns dark to save battery power. This is not a malfunction.*

6. Launch the Epson Link2 software.

For Windows:

Click Start, point to All Programs (or Programs), then select EPSON. Select Epson Link2, and then click Epson Link2.

Alternatively, click the Epson Link2 shortcut icon on the desktop.

For Macintosh:

Double-click the Epson Link2 icon in the Epson Link2 folder.

Only data that has not yet been backed up is copied to the computer automatically.

7. Disconnect the viewer from the computer.

For Windows:

Click Unplug or Eject Hardware on the computer screen, and then remove the USB cable.

For Macintosh:

Drag and drop the viewer icon and memory cards (if inserted) to the trash can on the computer screen, and then remove the USB cable.

Creating Custom Print

You can print out your photos by following the Print Wizard menu screen flows from editing photos to printing them out.

Using the Print Wizard Menu

Print Wizard has six menus to suit different purposes. See the following table for details on each menu.

1. On the Home screen, select Print Wizard using $\blacktriangle / \blacktriangledown$, then press $\textcircled{\text{OK}}$.

Note:

If an unprinted job is stored in the viewer, follow the instructions on the screen.

2. Select the menu you want using $\blacktriangle / \blacktriangledown$, then press $\textcircled{\text{OK}}$.

Menu	Details
Create Custom Print	You can edit photos and print them out.
Crop and Print	You can crop photos, lay them out on paper, and then print.

Menu	Details
Edit Layout and Print	You can lay photos out on paper and then print.
Make Copies of Custom Print	You can make additional prints of your photo projects.
Print Original Photo	You can print out the original photo.
Print Contact Sheet	You can print out a contact sheet displaying thumbnail images of your photos.

This section explains the simple flow of the Create Custom Print menu.

For details, see the User's Guide.

Selecting an Image

Select an image (JPEG/RAW file) to edit.



Retouching the selected image

Retouch the image. You can select current settings or make manual settings.

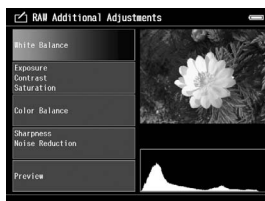

Cropping the selected image

You can crop the image to a custom size. You can also crop the image using a fixed aspect ratio.



Setting the print layout

You can set the image position on the paper, the background color, a watermark, and so on.

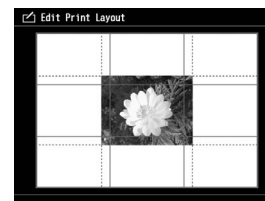

Printing photos

You can print by connecting the viewer directly to a printer.

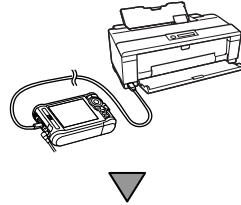

Finishing up

You can print by connecting the viewer directly to a printer.



By adjusting the LCD brightness and color temperature, you can make the images displayed on the LCD closer to the results of your printouts.

Chapter 6

Other Features

The viewer offers other functions apart from the functions introduced in this guide. For details about each function, see the User's Guide.

Viewing Images

Slide show

You can display JPEG and RAW photos as a slide show.

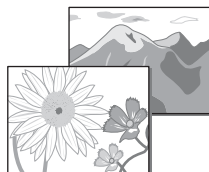

Screen saver

You can set photos as the screen saver.

Private folder

You can hide selected folders so that other people cannot view them.

Playing Music

Playlist

You can create a Playlist both on the Epson Link2 software and on the viewer.



Direct Printing

Photo print

You can print images directly with PictBridge enabled printers.



Viewing on TV

AV output

You can play slide shows and videos on TV.

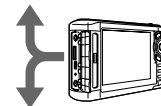

Customizing Settings

Settings mode

You can customize various settings to make the viewer more useful. Select Settings on the Home screen.

Troubleshooting

Problems and Solutions

You can also refer to the User's Guide for more detailed troubleshooting information.

Power supply problems

The power does not turn on.
Is the battery set correctly?
Make sure that the battery is installed correctly. See "Charging the battery" (page 7).
Has the battery run out?
Charge the battery. See "Charging the battery" (page 7).

The Charge lamp lights orange.

Is the battery set correctly?

See "Charging the battery" (page 7) and set the battery correctly.

Has the viewer been placed in a hot location?

Turn off the power, disconnect the AC adapter, stop charging, wait for more than 30 minutes, and then connect the AC adapter again to restart charging. If the Charge lamp still lights orange, contact our customer support.

Operation problems

Cannot use the keys on the viewer.

Is the power switch set to the middle?

If the power switch is set to HOLD, set it back to the middle.

Resetting the Viewer

When an error occurs and operations cannot be done, you can reset the viewer by pressing the Reset button with a thin object as shown below.

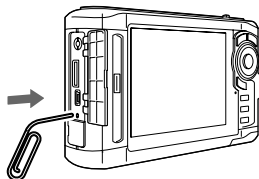

Note:

Avoid using fragile objects such as a pencil.

Formatting Data in the Viewer

You can delete all of the data from the viewer. Settings in the viewer itself are not deleted.

Note:

Before formatting, be sure to backup important data to an external hard disk, memory device, or computer.

1. Connect the AC adapter to the viewer.

2. Turn on the power while holding down **OK** and **Menu** simultaneously.
3. Select Yes using **▲ / ▼**, and then press **OK**.
4. Input the four digit password using **▲**, **▼**, and **OK**, and then press **OK** to finish.
5. When the format confirmation message appears, select Yes using **▲ / ▼**, and then press **OK**.
6. When a message appears indicating that formatting is complete, turn off the power.

