



Multimedia Storage Viewer **P-3000**  
Multimedia Storage Viewer **P-5000**

**Quick Reference Guide**

---

EPSON® is a registered trademark of Seiko Epson Corporation.

Microsoft® and Windows® are registered trademarks of Microsoft Corporation in the United States and/or other countries. Windows Media® is registered trademark of Microsoft Corporation in the United States and/or other countries.

Apple® and Macintosh® are registered trademarks of Apple Computer, Inc.

SD™ is a trademark.

This product is licensed under the MPEG-4 Visual Patent Portfolio License for the personal and non-commercial use of a consumer for (i) encoding video in compliance with the MPEG-4 visual standard (MPEG-4 Video) and/or (ii) decoding MPEG-4 Video that was encoded by a consumer engaged in a personal and non-commercial activity and/or was obtained from a video provider licensed by MPEG LA to provide MPEG-4 Video. No license is granted or shall be implied for any other use. Additional information including that relating to promotional, internal and commercial uses and licensing may be obtained from MPEG LA, L.L.C. - see <[www.mpegla.com](http://www.mpegla.com)>

MPEG Layer-3 audio coding technology is licensed from Fraunhofer IIS and Thomson.

Any use of this product other than consumer personal use in any manner that complies with the MPEG-2 standard for encoding video information for packaged media is expressly prohibited without a license under applicable patents in the MPEG-2 patent portfolio, which license is available from MPEG LA, L.L.C., 250 STEELE STREET, SUITE 300, DENVER, COLORADO 80206.

This product is licensed under the AVC Patent Portfolio License for the personal and non-commercial use of a consumer to (i) encode video in compliance with the AVC standard (AVC Video) and/or (ii) decode AVC Video that was encoded by a consumer engaged in a personal and non-commercial activity and/or was obtained from a video provider licensed to provide AVC Video. No license is granted or shall be implied for any other use. Additional information may be obtained from MPEG LA, L.L.C. - see <[www.mpegla.com](http://www.mpegla.com)>

DivX, DivX Certified, and associated logos are trademarks of DivX, Inc. and are used under license.

Adobe® and Adobe® RGB are registered trademarks of Adobe Systems Incorporated in the United States and/or other countries.

General Notice: Other product names used herein are for identification purposes only and may be trademarks of their respective owners. Epson disclaims any and all rights in those marks.

Copyright © 2006 Seiko Epson Corporation. All rights reserved.

# Contents

## Chapter 1 **Getting Started**

---

Unpacking the Viewer . . . . .	1
Parts . . . . .	1
Control Panel . . . . .	2
Setting Up the Viewer . . . . .	3
Preparing the battery . . . . .	3
Turning the power on/off . . . . .	4
Holding the key operations . . . . .	4
Initial settings . . . . .	5
Home screen . . . . .	6
Installing the Software . . . . .	7
System requirements . . . . .	7
How to install . . . . .	7

## Chapter 2 **Transferring the Data to the Viewer**

---

Transferring from CF/SD Memory Cards . . . . .	10
Transferring from a Digital Camera . . . . .	11
Connecting a digital camera . . . . .	11
Copying all data . . . . .	12
Copying particular data . . . . .	12

## Chapter 3 **Viewing Images**

---

Viewing Photos and Videos . . . . .	13
Switching the screen . . . . .	14
Icons on the screen . . . . .	14
Displaying information . . . . .	15
Zooming a photo . . . . .	15
Basic operations while playing videos . . . . .	15
Managing Files and Folders . . . . .	16
Copying files and folders . . . . .	16
Deleting files and folders . . . . .	16
Protecting files and folders . . . . .	17
Rating your photos . . . . .	18

## Chapter 4 **Backing Up Data from the Viewer**

---

Transferring to USB Storage Devices . . . . .	19
Transferring to the Computer . . . . .	19

## Chapter 5 **Playing Music**

---

Transferring Audio Data from the Computer . . . . .	21
Starting Playback . . . . .	22
Basic operations while playing music . . . . .	22
Repeat and shuffle play . . . . .	23

Problems and Solutions ..... 25  
Resetting the Viewer ..... 26

## **Safety instructions**

### **Warnings, Cautions, and Notes**



#### **Warnings**

*must be followed carefully to avoid bodily injury.*



#### **Cautions**

*must be observed to avoid damage to your equipment.*

#### **Notes**

*contain important information and useful tips on the operation of the viewer.*

## **When using the viewer**



#### **Caution:**

- ❑ *Do not expose the viewer to any impact, doing so may cause malfunctions.*
  
- ❑ *Do NOT format the viewer's hard disk drive from your computer, as this will render the viewer inoperable. If this happens, you should contact an authorized Epson service center. Repairs will be chargeable and are not covered by Epson's warranties.*
  
- ❑ *Do not drop or apply any shock to the viewer. Take care when carrying it, as strong shocks may damage the internal hard disk drive and cause data to be lost.*
  
- ❑ *Epson is not responsible for backing up or recovering data. We strongly recommend that you make your own backup files.*

#### **Note:**

*For other cautions and more information about the viewer usage, see the User's Guide.*

## Chapter 1

# Getting Started

### Unpacking the Viewer

Make sure that all of the items shown below are included in the box.

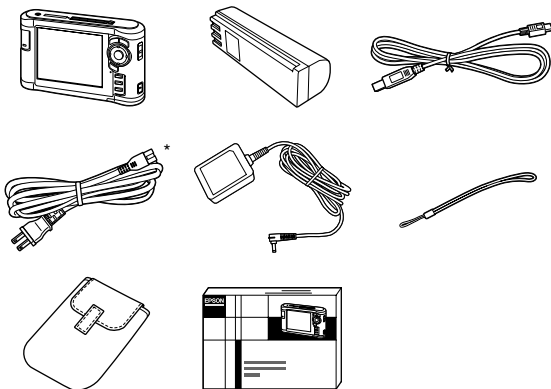

\* The plug type for the power cable may vary, depending on the local standards.

### Parts

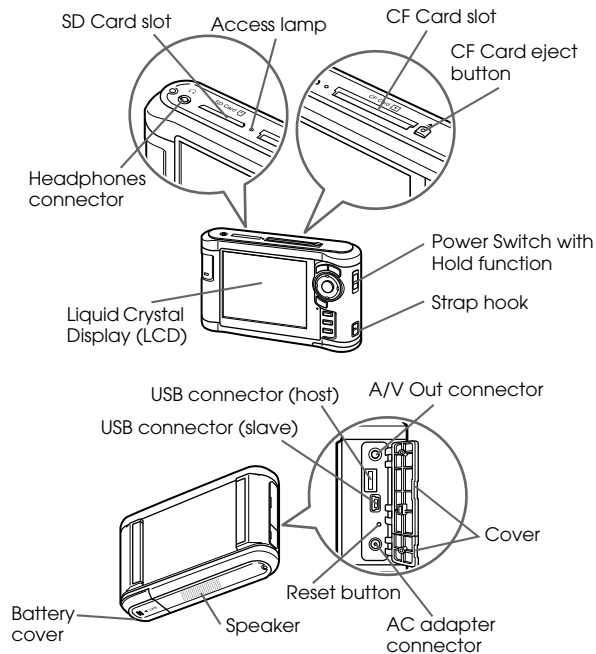

## Control Panel

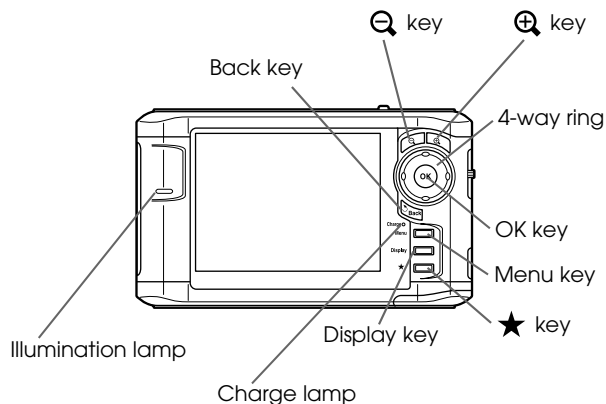

Back key	Press to cancel the selection and return to the previous screen.
Charge lamp	Lit green during battery charging. Lit orange when an error has occurred.
Menu key	Press to display the pop up menu.
Display key	Press to switch the screen.
★ key	Press to rate a particular photo and determine the selection. For details, see "Rating your photos" (page 18).
Illumination lamp (Blue)	Flashes during operations such as turning the power on, printing, LCD power-off mode, and so on.

⊕ / ⊖ key	Press to zoom a photo, and adjust the volume.
4-way ring (Up/ Down/Left/Right key)	Press to move the cursor or highlight. You can select an item by pressing this key to the up, down, left, or right.
OK key	Press to complete the selection and proceed to the next step.

## Setting Up the Viewer

### Preparing the battery

#### Installing the battery

1. Open the battery cover.

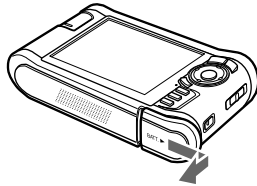

2. Insert the battery into the compartment in the direction of the arrow on the battery sticker.

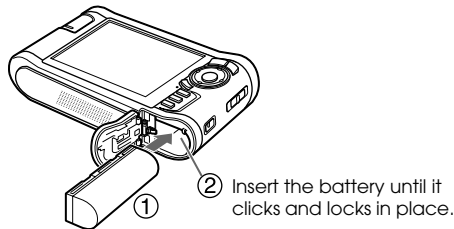

3. Close the battery cover and slide it to the left until it clicks.

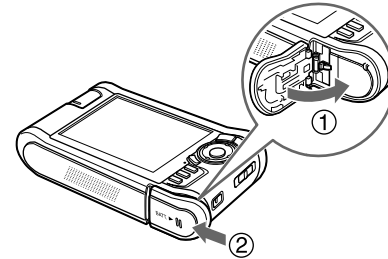

#### Charging the battery

Connect the AC adapter, then plug the other end into a power outlet.

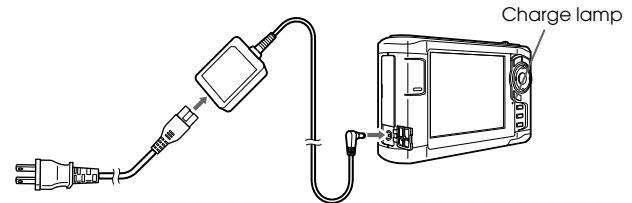

The Charge lamp lights green during charging. It takes about 3.5 hours to fully charge the battery when the power is off.



**Caution:**

- ❑ *Disconnect the AC adapter before removing the battery.*
- ❑ *Do not connect the AC adapter when the battery is not installed. Doing so may cause the viewer to be damaged.*
- ❑ *If the Charge lamp lights orange, see “Troubleshooting” (page 25).*

## Turning the power on/off

Make sure the battery is inserted.

Slide the power switch to I/⏻.

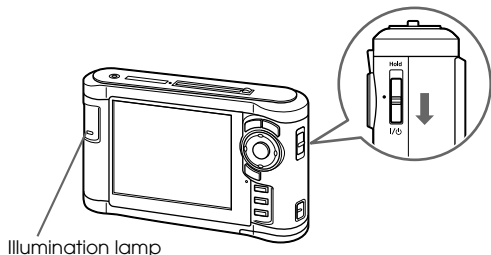

The Illumination lamp turns on.

To turn the power off, slide the power switch to I/⏻ and hold down until the shut down display appears.

## Holding the key operations

Slide the power switch to Hold.

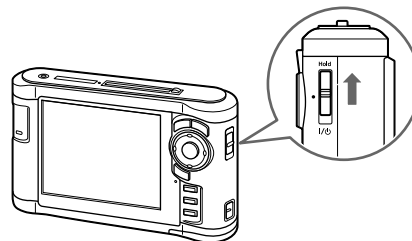

To release Hold, slide the power switch back to the middle.



## Initial settings

When you turn on the viewer for the first time, the setting screen appears.

Set the language, date and time.

1. Select the language to use with the Up or Down key, then press the OK key.



2. After the message saying “Set current Date and Time.” appears, press the OK key to proceed.

3. Set the date and time using the 4-way ring.

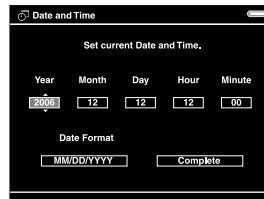

4. After you finish all settings, select Complete using the Right or Left key, then press the OK key.

**Note:**

*If approximately 24 hours passes after battery power is cut, the date and time settings may be lost, and will need to be set again.*

## Home screen

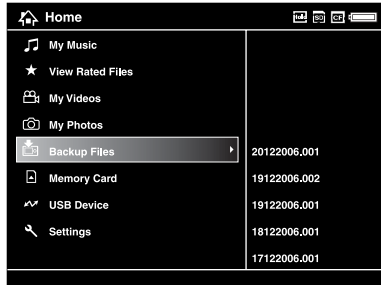

The following table shows the icon menu of the Home screen.

(Battery)	<ul style="list-style-type: none"> <li>: Indicates sufficient battery power.</li> <li>: Indicates moderate battery power.</li> <li>: Indicates low battery power.</li> <li>: Indicates the AC adapter is connected to the viewer.</li> </ul>
(CF)	Indicates the CF memory card is set (page 10).
(SD)	Indicates the SD memory card is set (page 10).
(Hold)	Indicates the key operations are on hold (page 4).

(My Music)	Select to listen to music transferred from the computer (page 22).
(View Rated Files)	Select to display rated files sorted by their rating.
(My Videos)	Select to display files/folders stored in the Videos folder.
(My Photos)	Select to display files/folders stored in the Photos folder.
(Backup Files)	Select to display files/folders backed up from CF/SD memory cards.
(Memory Card)	Select to display files on CF/SD memory cards or store memory card data onto the viewer.
(USB Device)	Select to transfer data between a USB device and the viewer.
(Settings)	Select to set the viewer's various settings.

## Installing the Software

You can transfer data from the computer to the viewer easily using the Epson Link2 software.

### System requirements

The system requirements for a computer are shown in the following table.

#### For Windows

Hard disk	1 GB or more free space is required for operation
OS	Microsoft® Windows®, 2000 Professional, XP Home Edition, XP Professional

#### For Macintosh

Hard disk	1 GB or more free space is required for operation
OS	Mac OS X 10.2 or later

## How to install

You are required to install the data in the viewer. Connect the viewer to the computer, then install the necessary software. For details about computer connection, see “Transferring to the Computer” (page 19).

### For Windows users

**Note:**

- ❑ Do not delete the installer (EXE file) in the viewer's hard disk.
- ❑ It is recommended to back up the installer onto the computer.
- ❑ For Windows XP and Windows 2000, you need administrative privileges to install the software.

1. Connect the viewer to the computer.
2. Click Start, select My Computer, then click the viewer's hard disk drive icon.
3. Double-click the P\_XXXX\_WIN\_SOFTWARE icon.

**Note:**

P\_XXXX is the model name of your viewer.

4. Select Desktop to decompress the files onto, then click Yes.

5. On the software installation screen, click Easy Install.

**Note:**

*If you are prompted to select a language, select your preferred language.*

6. When the software license agreement screen appears, read the statement and then click Agree.

7. Select your country, then follow the on-screen instructions.

8. When a message appears indicating that installation is complete, click Exit or Restart Now.

**Note:**

*When Restart Now appears, click the button to restart your computer.*

## **For Macintosh users**

**Note:**

*It is recommended to back up the installer onto the computer.*

*You need administrative privileges to install the software.*

1. Connect the viewer to the computer.

The viewer's hard disk icon appears on the desktop.

2. Double-click the P\_XXXX\_MAC\_SOFTWARE icon in the viewer's hard disk on the desktop.

**Note:**

*P\_XXXX is the model name of your viewer.*

3. Double-click the MacOSX icon.

4. On the software installation screen, click Easy Install.

**Note:**

*If you are prompted to select a language, select your preferred language.*

5. When the software license agreement screen appears, read the statement and then click Agree.
6. Select your country, then follow the on-screen instructions.

If the Authenticate window appears, click the key icon, enter the administrator's name and password, then click OK.

7. When a message appears indicating that installation is complete, click Exit or Restart Now.

**Note:**

*When Restart Now appears, click the button to restart your computer.*

# Transferring the Data to the Viewer

You can transfer the data taken with a digital camera to the viewer.

## Transferring from CF/SD Memory Cards

1. Insert the memory cards with the label side facing the display side of the viewer.

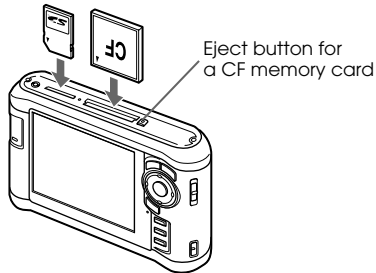

### Note:

- ❑ You can keep both a CF memory card and an SD memory card loaded in their respective slots simultaneously.
- ❑ Be sure to use the viewer with the eject button pushed in to avoid possible damage.

2. Select  Memory Card in the Home screen using the Up or Down key, then press the OK key.
3. In the Memory Card screen, select CF Memory Card Backup or SD Memory Card Backup using the Up or Down key.

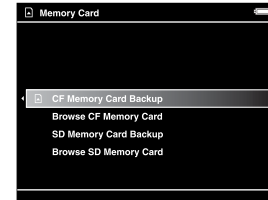

4. Press the OK key to start copying.

After the copy completes, the backup data is displayed automatically.

5. Make sure that the Access lamp is off before removing the memory cards.
6. For a CF memory card, push the eject button twice. For an SD memory card, push the memory card down slightly then release, and it will pop up for you to remove completely.

**Note:**

- ❑ *Before copying data, charge the battery fully. If the battery is low, connect the AC adapter.*
- ❑ *1GB of data may take approximately 3 to 5 minutes or more to copy, depending on the memory card you use.*

### Supported memory card types

CF (CompactFlash) memory card (Type2 and 3.3 V, including Micro Drive)
SD memory card (up to 2 GB), SD High-Capacity card
MultiMedia Card (up to 1 GB), MultiMedia Card Plus

Commercially available adapters will be required to use other memory cards (miniSD, RS-MMC, Memory Stick Duo, Memory Stick PRO Duo, xD-Picture Card, and so on). Contact our customer support for details.

## Transferring from a Digital Camera

You can transfer data to the viewer directly from digital cameras that support the USB Mass Storage specification.

### Connecting a digital camera

1. Connect the AC adapter to the viewer.

**Note:**

*When the remaining battery is low on your digital camera, connect the AC adapter.*

2. Open the side upper cover of the viewer and connect a USB cable to the Host (Standard-A) connector. Then connect the other end to your digital camera.
3. Turn on the viewer and your digital camera.

**Note:**

- ❑ *Use the USB cable supplied with your camera to connect.*
- ❑ *Do not connect USB interfaces of the viewer (Host-Standard A and Slave-Mini B) at the same time. It may cause a malfunction.*
- ❑ *Do not touch the Slave-Mini B connector interface during the USB data transfer.*

## Copying all data

You can transfer all the data in a digital camera to the viewer in a single operation.

1. Select  USB Device in the Home screen using the Up or Down key, then press the OK key.
2. Select Backup USB device to Viewer using the Up or Down key, then press the OK key.

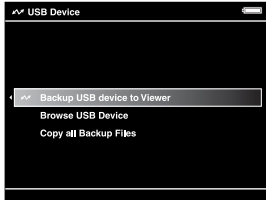

### Note:

- ❑ Connecting a digital camera through the USB hub is not supported.
- ❑ Transfer time varies depending on your digital camera, but generally, 1 GB of data will take approximately 5 to 10 minutes.

## Copying particular data

You can select specific data to copy to the viewer.

1. Select  USB Device in the Home screen using the Up or Down key, then press the OK key.
2. In the USB Device screen, select Browse USB Device using the Up or Down key.

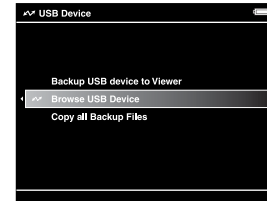

3. Press the OK key to show the data on the USB device.
4. Press the Menu key to display the pop up menu, select Backup using the Up or Down key, then press the OK key.
5. Use the 4-way ring and the  key to enter checkmarks in the check boxes of files to back up, then press the OK key to complete.





## Chapter 3

# Viewing Images

You can view and edit images on the viewer.

## Viewing Photos and Videos

1. Select  Backup Files,  My Photos, or  My Videos in the Home screen using the Up or Down key, then press the OK key.

**Note:**

You can transfer data from the computer to My Photos or My Videos using the Epson Link2 software. You can copy from Backup Files on the viewer. For details, see "Copying files and folders" (page 16).

2. Select a folder to view using the 4-way ring, then press the OK key. (If there is no folder, skip this step.)
3. Select a file to view using the 4-way ring, then press the OK key.

**Note:**

When viewing photos, pressing the Right key displays the next image and pressing the Left key displays the previous image.

### Supported photo/video file formats

File	Format
Photo	JPEG, RAW
Video	MPEG1/2, MPEG4, H.264/AVC, WMV9, MJPEG, DivX

**Note:**

For details on the supported file formats, see the User's Guide.

## Switching the screen

You can switch the following screen by pressing the Display key.

### Thumbnails screen

Files or folders appear in 12 divided thumbnails.

### Mini-thumbnails screen

Files or folders appear in 64 divided thumbnails.

### Details screen

The modify date and file size are displayed.

## Icons on the screen

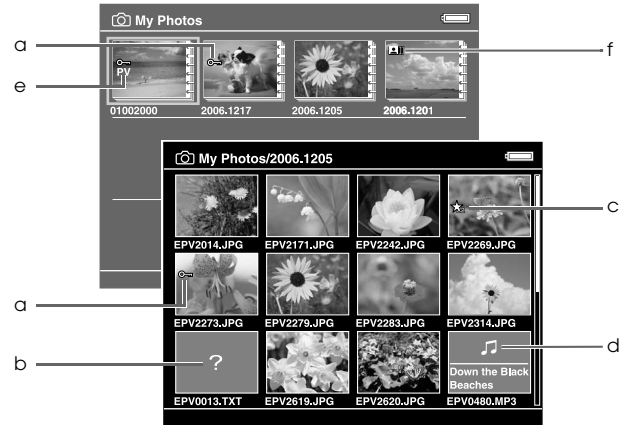

a	Indicates that the file or folder is locked.
b	Indicates unsupported data, such as a document.
c	Indicates that the file is set with the rating information.
d	Indicates the file is in music format.
e	Indicates that the folder is set as a private folder.
f	Indicates that the folder is set as the screen saver.

### Note:

For details about the screen icon, see the User's Guide.

## Displaying information

When viewing a photo or video, press the Display key to display its information.

### Photo

For a photo file, pressing the Display key twice displays the EXIF information with histograms (as below). You can switch to the over-under exposure preview by pressing the Display key again.

### Video

For a video file, the progress information is displayed at first. You can switch to the file information (as below) by pressing the Display key again.

### Zooming a photo

Press the  key to zoom in on a photo displayed in full screen. Continue pressing it to zoom in even further. You can move around the zoomed photo using the 4-way ring.

## Basic operations while playing videos

Key	Function
OK	Play/Pause
Back*	Stops the video and returns to the previous screen.
	Adjusts the volume.
Left/Right	Rewind/Fast-forward**

\* When you press the Back key to stop playback, the viewer remembers the resume point for the next time you start playback. The next time you start playback, playback starts from 3 seconds before the resume point. If you want to play back the video from the beginning, press the Menu key during playback, select Play Settings, Play from Beginning, then press the OK key. This function cannot be used for a video with total playback time of 1 minute or less. (Resume does not work for some video files.)

\*\* Rewind and fast-forward speed become faster if you press the Left/Right key several times while rewinding/fast-forwarding. (Rewind/Fast-Forward does not work for some video files.)

---

## Managing Files and Folders

### Copying files and folders

1. Highlight a file or folder to copy to My Photos or My Videos.
2. Press the Menu key to display the pop up menu, select Copy/Move using the Up or Down key, then press the OK or Right key.
3. Select Copy to Folder using the Up or Down key, then press the OK key.
4. Use the 4-way ring and the ★ key to enter checkmarks in the check boxes of files or folders to copy, then press the OK key to complete.
5. Select My Photos or My Videos using the Up or Down key, then press the Right key.
6. Select a folder to copy to using the 4-way ring, then press the OK key.

You can also create a new folder. Select Create New Folder, then input the folder's name. To input the folder's name, see the User's Guide.

### Deleting files and folders

1. Highlight a file or folder to delete.
2. Press the Menu key to display the pop up menu, select Delete using the Up or Down key, then press the OK key.

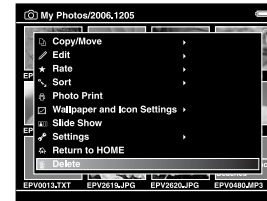

3. Use the 4-way ring and the ★ key to enter checkmarks in the check boxes of files or folders to delete, then press the OK key to complete.

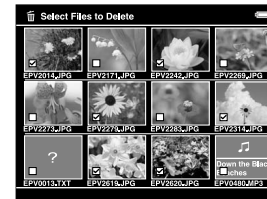



- After the confirmation dialog box appears, select Yes using the Up or Down key, then press the OK key to complete.

## Protecting files and folders

You can lock the selected file or folder. When a file or folder is locked, the  icon is displayed and it cannot be deleted or rotated.

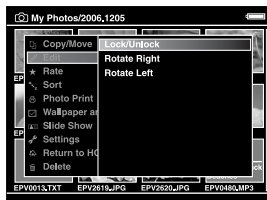
- Highlight a file or folder to lock.
- Press the Menu key to display the pop up menu, select Edit using the Up or Down key, then press the OK or Right key.
- Select Lock/Unlock using the Up or Down key, then press the OK key.



- Use the 4-way ring and the  key to enter checkmarks in the check boxes of files or folders to lock, then press the OK key to complete. (Files or folders which have already been locked are displayed with checkmarks. Pressing the  key removes the checkmark and unlocks the file or folder.)

### Note:

*The lock on the file or folder remains in effect until you unlock it, even if you turn off the viewer.*

## Rating your photos

You can quickly view rated photo files from ★ View Rated Files in the Home screen after rating files.

After selecting a photo file in the My Photos or Backup Files, press the ★ key. You can rate photos from ★ 1 to ★ 5.

### **Note:**

- ❑ You cannot rate music or movie files.
  - ❑ When a photo file is rated ★ 5, pressing the ★ key deletes its rating.
  - ❑ You can rate up to 3000 files.
  - ❑ If you delete a file from My Photos, My Videos, or Backup Files, the corresponding rated file will also be deleted from View Rated Files.
  - ❑ If you delete a file from View Rated Files, the original file which is in My Photos, My Videos or Backup Files is not deleted, but the rating information is deleted.
  - ❑ If you copy a rated file, the rating information is not copied.
- ❑ To edit a file that you rated with the viewer using AdobeBridge, see the online Epson Link2 User's Guide.

---

# Backing Up Data from the Viewer

You can transfer data from the viewer to the computer. Be sure to back up important data.

---

## Transferring to USB Storage Devices

You can transfer the data to other USB devices. For detail, see the User's Guide.

You can use the following USB storage devices capable of copying: external HDD drives, USB memories, and card reader/writers.

---

## Transferring to the Computer

Before transferring, install the Epson Link2 software.

1. Connect the AC adapter.
2. Turn on the viewer and the computer.

**Note:**

*After connecting the viewer to the computer, the LCD turns dark to save battery power. This is not a malfunction.*

3. Open the USB connector's cover and connect the USB cable to the viewer. Then connect the other end of the USB cable to the computer.

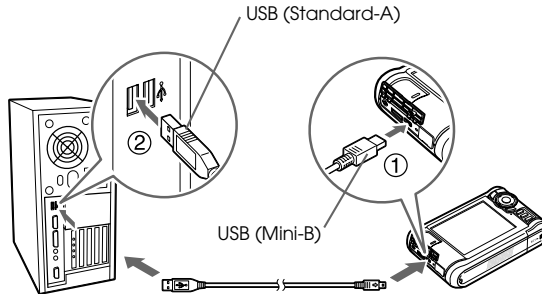

The LCD turns off.

**Note:**

When the viewer is connected to a computer, do not connect a USB device to the Host-standard A, or touch the connector interface.

4. Launch the Epson Link2 software.

**For Windows:**

Click Start, point to All Programs (or Programs), then select EPSON. Select Epson Link2, then click Epson Link2.

Alternatively, click the shortcut icon of the Epson Link2 software on the desktop.

**For Macintosh:**

Double-click the Epson Link2 icon in the Epson Link2 folder.

Only data that has not yet been backed up will be copied to the computer automatically.

5. Disconnect the viewer from the computer.

**For Windows:**

Click Unplug or Eject Hardware on the computer screen, then remove the USB cable.

**For Macintosh:**

Drag and drop the viewer icon and memory cards (if inserted) to the trash can on the computer screen, then remove the USB cable.



## Chapter 5

# Playing Music

You can transfer audio data from the computer and play them back on the viewer.

## Transferring Audio Data from the Computer

After connecting the viewer to the computer, transfer audio data from the computer to the viewer using the Epson Link2 software.

**Note:**

*For details, see the online Epson Link2 User's Guide.*

## Supported audio file formats

File Format	Audio Codec	Details
M4A* **	AAC (MPEG4)	Maximum bit rate: 320 kbps (48 kHz, 16 bit Stereo)
MP3*	MP3 (MPEG1/2/2.5 - Layer 3)	Maximum bit rate: 320 kbps (48 kHz, 16 bit Stereo)
WMA* **	Windows Media Audio 9	Bit rate: 48 to 192 kbps (48 kHz, 16 bit Stereo)

\* Without copyright protection.

\*\* Non-Lossless-compliant format.

---

## Starting Playback

1. Select  My Music in the Home screen using the Up or Down key, then press the OK key.
2. Select Music List using the Up or Down key, then press the OK or Right key.

**Note:**

Selecting Resume enables you to start resume play from the beginning of the previously played track.

3. Select a category to start playback using the Up or Down key, then press the OK or Right key.

**Note:**

A category can be selected from Artist, Album, Genre, All, or Playlist. After transferring audio data from the computer, select Update Music List.

4. Select the desired track using the 4-way ring, then press the  key to start playback.

## Basic operations while playing music

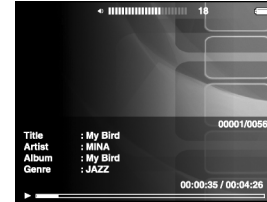

Key	Operation
OK	Play/Pause
Back	Played from My Videos/Backup Files: Stops playing and returns to the previous screen. Played from My Music: Returns to the music browse screen without stopping music playback.
	Adjusts the volume.
Right/Left	Skips back/forward.*
Display	Displays Codec, Bit Rate, and Sampling Rate.**

\* Pressing and holding the Left/Right key rewinds/fast-forwards the music.

\*\* The information contained in the ID3 tag (the name of file, track, artist, and so on) is displayed. The ID3 tag versions up to 2.4 are compatible, and up to 127 characters are displayable.

## ***Repeat and shuffle play***

Press the Menu key to display the pop up menu in   
My Music, select Play Mode and set the following  
items using the 4-way ring and the OK key.

### ***Repeat setting***

<b>Select</b>	<b>To play</b>
No Repeat	current category once
Repeat One Song	current track repeatedly
Repeat All	current category repeatedly

### ***Playback order setting***

<b>Select</b>	<b>To play</b>
Shuffle	current category in random order
Normal Play Order	current category in normal order

# Other Features

---

You can enjoy other functions than the features introduced in this guide with this viewer. For details about each function, see the User's Guide.

### Viewing Images

#### Slide show

You can display JPEG and RAW photos as a slide show.

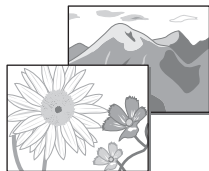

#### Screen saver

You can set photos as the screen saver.

#### Private folder

You can hide selected folders so that other people cannot view them.

### Playing Music

#### Playlist

You can create a Playlist both on the Epson Link2 software and on the viewer.



### Direct Printing

#### Photo and Video print

You can print images directly with PictBridge enabled printers.



### Viewing on TV

#### AV output

You can play slide shows and videos on TV.

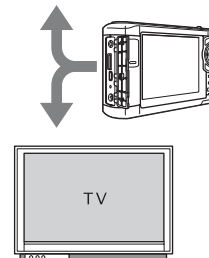

### Customizing Settings

#### Settings mode

You can customize various settings to make the viewer more useful. Select Settings in the Home screen.

## Chapter 7

# Troubleshooting

### Problems and Solutions

You can also refer to the User's Guide as it has the detailed troubleshooting information.

#### Power supply problems

<b>The power does not turn on.</b>
Is the battery set correctly?
Make sure that the battery is installed correctly. See "Installing the battery" (page 3).
Has the battery run out?
Charge the battery. See "Charging the battery" (page 3).

#### **The Charge lamp lights orange.**

Is the battery set correctly?

See "Installing the battery" (page 3) and set the battery correctly.

Has the viewer been placed in a hot location?

Turn off the power, disconnect the AC adapter, stop charging and wait more than 30 minutes, then connect the AC adapter again to restart charging. If the Charge lamp still lights orange, contact our customer support.

#### Operation problems

#### **Cannot use the keys on the viewer.**

Is the power switch set to the middle?

If the power switch is set to Hold, set it back to the middle.

---

## Resetting the Viewer

When an error occurs and operations cannot be done, you can reset the viewer by pressing the Reset button with a thin object as shown below.

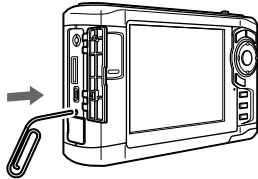

**Note:**

*Avoid using the fragile objects such as pencil.*