

EPSON

Color Image Scanner

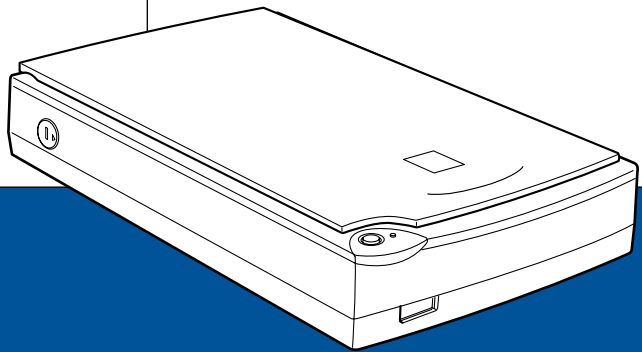

Perfection 1200

User's Guide

4010810
S01-00

Where to Find Information

This User's Guide

This guide leads you through the scanner setup and options installation, tells you how to use the scanner, and how to make basic scans.

It also leads you through the EPSON scanner software installation, tells you how to use the Start Button function, and how to make basic software settings. Finally, it also offers troubleshooting tips, customer support information and calibrating information.

Online EPSON Scanner Software Reference Guide

Provides basic information about scanning and detailed reference on the settings and functions of EPSON TWAIN and other EPSON scanner utility software.

Online Color Guide (may not be available in some countries)

Explains the basics of color imaging and shows you how to get impressive results from your scanner and other EPSON products.

Information on EPSON TWAIN

Online help provides you with detailed information on EPSON TWAIN. Access online help by clicking the ? button in the EPSON TWAIN dialog box.

Information on PageManager and other Software

See the PageManager for EPSON, and other software documentation provided on the EPSON Scanner Software CD-ROM.

EPSON® *Perfection* 1200U *Perfection* 1200S *Perfection* 1200PHOTO

Color Image Scanner

All rights reserved. No part of this publication may be reproduced, stored in a retrieval system, or transmitted in any form or by any means, electronic, mechanical, photocopying, recording, or otherwise, without the prior written permission of SEIKO EPSON CORPORATION. No patent liability is assumed with respect to the use of the information contained herein. Neither is any liability assumed for damages resulting from the use of the information contained herein.

Neither SEIKO EPSON CORPORATION nor its affiliates shall be liable to the purchaser of this product or third parties for damages, losses, costs, or expenses incurred by purchaser or third parties as a result of: accident, misuse, or abuse of this product or unauthorized modifications, repairs, or alterations to this product.

SEIKO EPSON CORPORATION and its affiliates shall not be liable against any damages or problems arising from the use of any options or any consumable products other than those designated as Original EPSON Products or EPSON Approved Products by SEIKO EPSON CORPORATION.

EPSON is a registered trademark of SEIKO EPSON CORPORATION.

IBM and PS/2 are registered trademarks of International Business Machines Corporation.

Macintosh is a registered trademark of Apple Computer, Inc.

Microsoft and Windows are registered trademarks of Microsoft Corporation in the United States of America and other countries.

Presto! is a trademark of NewSoft Technology Corporation.

General Notice: Other product names used herein are for identification purposes only and may be trademarks of their respective companies.

Copyright © 1999 by SEIKO EPSON CORPORATION, Nagano, Japan.



Printed on Recycled Paper.

User's Guide

Declaration of Conformity

Manufacturer: SEIKO EPSON CORPORATION
Address: 3-5, Owa 3-chome, Suwa-shi,
Nagano-ken 392-8502 Japan

Representative: EPSON EUROPE B.V.
Address: Prof. J. H. Bavincklaan 5 1183
AT Amstelveen
The Netherlands

Declares that the Product:

Product Name: Image Scanner
Model: G752A/G752B

Conforms to the following Directive(s) and Norm(s):

Directive 89/336/EEC:

EN 55022 Class B
EN 61000-3-2
EN 61000-3-3
EN 50082-1
IEC 801-2
IEC 801-3
IEC 801-4

Directive 73/23/EEC:

EN 60950

July, 1999

H. Horiuchi
President of EPSON EUROPE B.V.

Contents

Safety Instructions

Important Safety Instructions	1
Warnings, Cautions, and Notes.	2
ENERGY STAR Compliance	3
For United Kingdom Users	3
Safety information	3

Chapter 1 Getting to Know Your Scanner

Features.	1-2
Unpacking the Scanner.	1-3
Scanner Parts	1-4
Lights and Buttons	1-6
Options	1-7

Chapter 2 Setting Up the Scanner

Choosing a Place for the Scanner	2-2
Installing a SCSI Interface Board.	2-4
Releasing the Transportation Lock.	2-5
Plugging in the Scanner	2-6
Initialization	2-7
Connecting the Scanner (SCSI) to Your Computer.	2-8
Understanding SCSI connections.	2-9
Setting the SCSI ID number	2-10
Setting the terminator switch	2-12
Connecting the scanner	2-13
Power-on sequence.	2-15
Power-off sequence	2-16
Connecting the Scanner (USB) to Your Computer	2-16
Understanding USB connections	2-17

Connecting the scanner	2-18
Installing the Scanner Software	2-19

Chapter 3 Installing the Software

System Requirements	3-2
For PCs	3-2
For Macintosh computers and SCSI model users.....	3-3
For Macintosh computers and USB model users	3-4
Installing the Scanner Software for Windows	3-5
For Windows 98 users	3-5
For Windows 95 and Windows NT 4.0 users	3-15
Upgrading from Windows 95 to Windows 98	3-21
Installing the Scanner Software for Macintosh	3-23
Calibrating Your Screen	3-25

Chapter 4 Using Your Scanner

Scanning Procedure	4-2
Placing a Document on the Scanner	4-2
Removing the Cover for Thick or Large Documents	4-6
Starting EPSON TWAIN	4-8
Scanning an Image	4-9
Scanning From the Easy Menu	4-10
Scanning From the Advanced Menu	4-14
Saving the Scanned Image	4-18
Scanning by Pressing the Start button.....	4-19

Chapter 5 Using the Start Button

The Start Button Feature	5-2
PageManager for EPSON	5-2
Target applications in the Scan Buttons bar	5-2
Assigning an application to the Start button.....	5-3
Adding Applications to the Scan Buttons Bar.....	5-5
Registering new applications.....	5-6

Setting Up EPSON Scanner Monitor	5-8
Setting Up the Start Button Feature for Windows 98.....	5-12

Chapter 6 Options

Using the Film Adapter	6-2
Unpacking the Film Adapter	6-2
Installing the Film Adapter.....	6-3
Scanning transparent materials	6-4
Film holders.....	6-4
Loading slides and film	6-6
Scanning normal (reflective) documents	6-12
Using the Automatic Document Feeder.....	6-13
Unpacking the Automatic Document Feeder.....	6-13
Installing the Automatic Document Feeder.....	6-14
Loading paper into your Automatic Document Feeder...	6-16
Loading documents manually	6-17
Scanning from the Automatic Document Feeder	6-18
Fixing paper jams in the Automatic Document Feeder ...	6-20
Document specifications	6-22

Chapter 7 Maintenance and Troubleshooting

Maintenance	7-2
Cleaning the scanner	7-2
Replacing the fluorescent lamp	7-3
Cleaning or replacing the paper path guide.....	7-3
Transporting the Scanner.....	7-7
Problems and Solutions	7-8
Error indicator.....	7-9
Operating problems.....	7-10
Quality problems	7-13
Software setup problems.....	7-20
Software operation problems.....	7-22
Scanning problems.....	7-24
Paper jams	7-26
Changing the SCSI ID number or SCSI board.....	7-27

Sizing Up Your System	7-28
RAM and hard disk size	7-28
Accelerator boards	7-29
Video cards	7-29
Monitors	7-29
File compression software	7-29

Appendix A Technical Specifications

Scanning	A-2
Electrical	A-4
Environmental	A-4
Safety Approvals	A-5
CE marking	A-5
SCSI Interface	A-6
USB Interface	A-7
Initialization Methods	A-8
Film Adapter	A-9
Automatic Document Feeder	A-10

Appendix B Contacting Customer Support

For United Kingdom and the Republic of Ireland Users	B-3
For Australian Users	B-5
For Singapore Users	B-6
For Hong Kong Users	B-7
For Philippines Users	B-8

Glossary

Index

Safety Instructions

Important Safety Instructions

Read all these instructions and save them for later reference. Follow all warnings and instructions marked on the scanner.

- ❑ Unplug the scanner before cleaning. Clean with a damp cloth only. Do not spill liquid on the scanner.
- ❑ Do not place the scanner on an unstable surface, or near a radiator or heat source.
- ❑ Use only the type of power source indicated on the scanner's label.
- ❑ Connect all equipment to properly grounded power outlets. Avoid using outlets on the same circuit as photocopiers or air control systems that regularly switch on and off.
- ❑ Do not let the power cord become damaged or frayed.
- ❑ If you use an extension cord with the scanner, make sure the total ampere rating of the devices plugged into the extension cord does not exceed the cord's ampere rating. Also, make sure the total ampere rating of all devices plugged into the wall outlet does not exceed the wall outlet's ampere rating.
- ❑ Except as specifically explained in this *User's Guide*, do not attempt to service the scanner yourself.
- ❑ Unplug the scanner and refer servicing to qualified service personnel under the following conditions:

If the power cord or plug is damaged; if liquid has entered the scanner; if the scanner has been dropped or the case damaged; if the scanner does not operate normally or exhibits a distinct change in performance. (Do not adjust controls that are not covered by the operating instructions.)

- ❑ If you plan to use the scanner in Germany, observe the following:

To provide adequate short-circuit protection and over-current protection for this scanner, the building installation must be protected by a 16 Amp circuit breaker.

Note for German-speaking users:

Bei Anschluß des Scanners an die Stromversorgung muß sichergestellt werden, daß die Gebäudeinstallation mit einem 16 A-Überstromschalter abgesichert ist.

Warnings, Cautions, and Notes



Warnings must be followed carefully to avoid bodily injury.



Cautions must be observed to avoid damage to your equipment.

Notes contain important information and useful tips on the operation of your scanner.

ENERGY STAR Compliance

As an ENERGY STAR Partner, EPSON has determined that this product meets the ENERGY STAR guidelines for energy efficiency.



The International ENERGY STAR Office Equipment Program is a voluntary partnership with the computer and office equipment industry to promote the introduction of energy-efficient personal computers, monitors, printers, fax machines, copiers, and scanners, in an effort to reduce air pollution caused by power generation.

For United Kingdom Users

Safety information



Warning: *This appliance must be earthed. Refer to the rating plate for voltage and check that the appliance voltage corresponds to the supply voltage.*

Important: *The wires in the mains lead fitted to this appliance are coloured in accordance with the following code:*

Green and yellow — Earth

Blue — Neutral

Brown — Live

As the colours of the wires in the mains lead of this appliance may not correspond with the coloured markings identifying the terminals in your plug, proceed as follows:

The green and yellow wire must be connected to the terminal in the plug which is marked with the letter E or with the earth symbol (\perp).

The blue wire must be connected to the terminal in the plug marked with the letter N.

The brown wire must be connected to the terminal in the plug marked with the letter L.

If damage occurs to the plug, replace the cord set or consult a qualified electrician.

Replace fuses only with a fuse of the correct size and rating.

Features 1-2

Unpacking the Scanner 1-3

Scanner Parts 1-4

Lights and Buttons 1-6

Options 1-7

Features

The EPSON Perfection 1200U/Perfection 1200S/Perfection 1200PHOTO scanner offers the following features:

- ❑ Optical resolution of 1200 dots per inch (dpi) for main scanning, and 2400 dpi with micro step for sub scanning (36-bit input, 24-bit output).
- ❑ Start Button control for shortcut scanning operation.
- ❑ Light body with A4/Letter size scanning area.
- ❑ Full color or grayscale scanning. Capture your images with over 16 million colors, or up to 256 shades of gray.
- ❑ EPSON TWAIN lets you take full advantage of your scanner's advanced features.
- ❑ EPSON TWAIN's Unsharp Mask option automatically sharpens the image to provide crisp detail.
- ❑ EPSON TWAIN's "De-screening" option automatically removes unwanted moiré patterns from scanned images for higher quality output.
- ❑ Auto Area Segmentation (AAS) allows you to separate text from photographs on a page so that grayscale images are clearer and text recognition is more accurate.
- ❑ Text Enhancement Technology (TET) enhances text recognition accuracy for optical character recognition (OCR) scanning.
- ❑ The Perfection 1200PHOTO includes the Film Adapter which enables negative film and slide film to be scanned. The Film Adapter is available as an option for the Perfection 1200S/Perfection 1200U.
- ❑ The Automatic Document Feeder which enables continuous sheet scanning is available as an option.

Unpacking the Scanner

Your Perfection 1200U/Perfection 1200S/Perfection 1200PHOTO comes shipped with CD-ROMs which include the driver software that runs your scanner, and some additional items, depending on your scanner model.

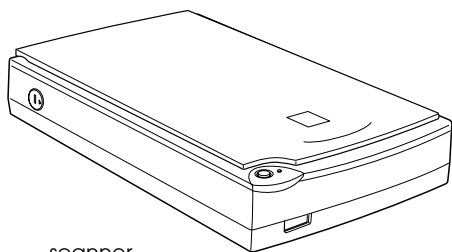

scanner

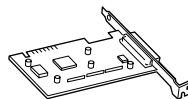

SCSI interface board
(SCSI model only)

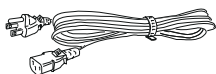

power cord

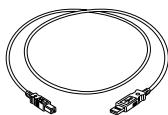

USB interface cable
(USB and PHOTO models only)

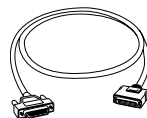

SCSI interface cable
(SCSI model only)

For the Perfection 1200PHOTO

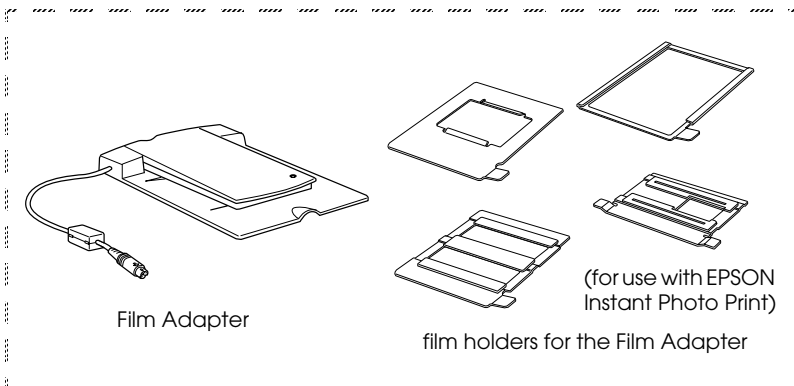

Film Adapter

(for use with EPSON
Instant Photo Print)

film holders for the Film Adapter

Note:

The Perfection 1200PHOTO comes with the Film Adapter which is also available as an option for Perfection 1200S/Perfection 1200U.

Depending on the country of purchase, the power cord may come attached to the scanner. The shape of the AC plug also varies, so make sure the plug included is the correct shape for the electrical outlet in your country.

Scanner Parts

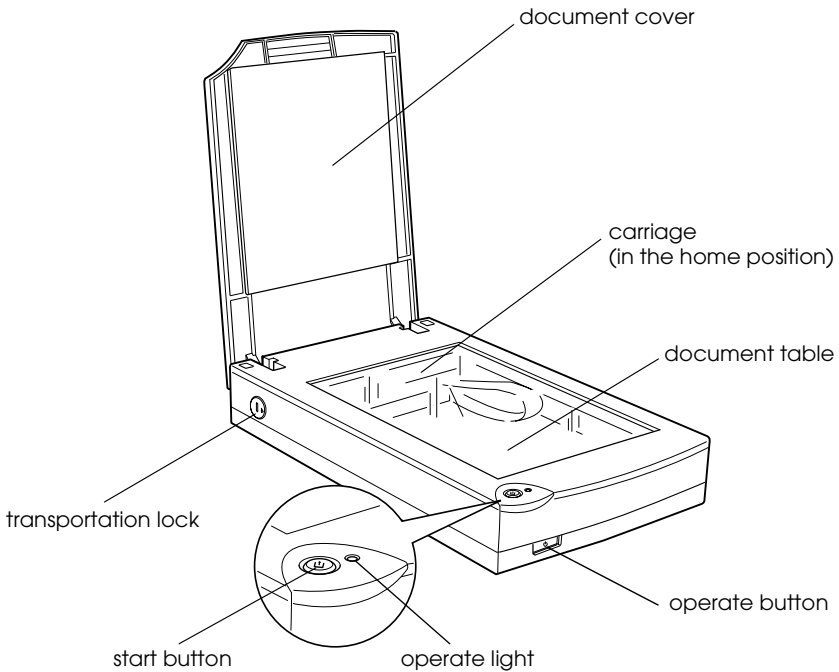

SCSI model

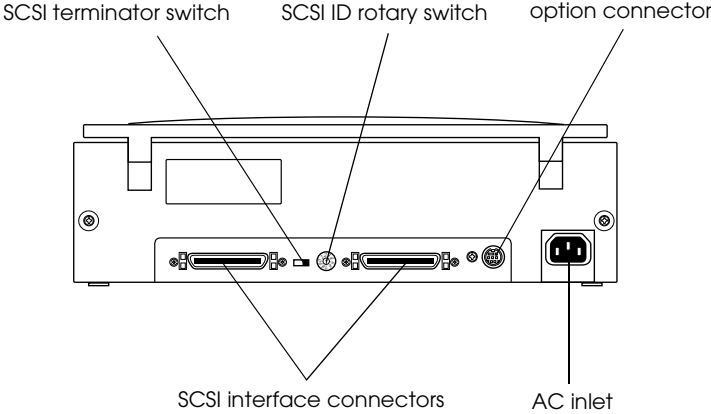

USB (and Photo) model

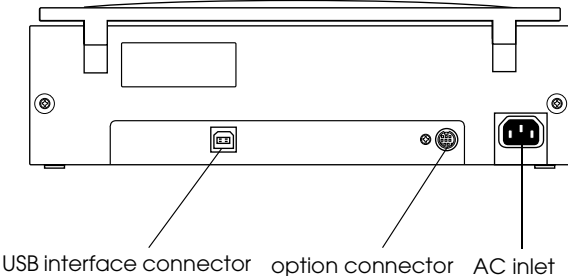

Lights and Buttons

The scanner has one indicator light and two buttons.

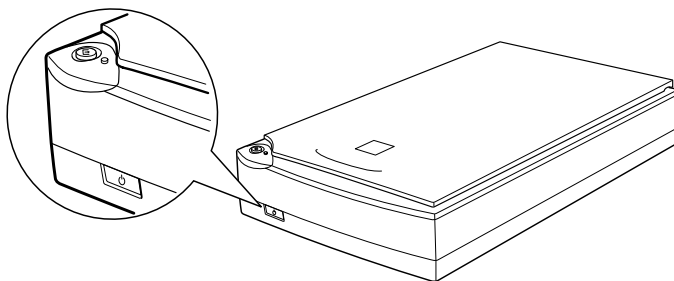



Light

Pattern	Color	Scanner Status
◐ (Slowly flashing)	Green	Initializing or busy scanning.
○	Green	Ready to scan images.
◑ (Rapidly flashing)	Red or Orange	An error occurred. See Chapter 7 Maintenance and Troubleshooting on page 7-9 for more information.
●	N/A	The scanner is turned off.

○ = on, ● = off, ◐ = flashing

Buttons

Button	Function
 Operate	Turns the scanner on and off.
 Start	The hardware switch to execute scanning and transfer the scanned image to assigned application software. To use this feature, you need to setup software. See Chapter 3 for more details.

Options

The following optional items are available to expand the versatility of your scanner. For detailed information on the use of these options, see Chapter 6 of this guide.

Automatic Document Feeder (B81314*)

Designed primarily for optional character recognition (OCR) scanning, the Automatic Document Feeder allows you to scan up to 20 pages automatically, then use them in word processing programs, as if you had typed the text yourself.

Film Adapter (B81317*)

Allows you to scan transparent materials; primarily 35 mm slides and filmstrips. The Film Adapter's reading area allows you to scan film up to 4 × 5 inches in size.

Note:

The asterisk is a substitute for the last digit of the product number, which varies by country.

Setting Up the Scanner

Choosing a Place for the Scanner 2-2

Installing a SCSI Interface Board 2-4

Releasing the Transportation Lock 2-5

Plugging in the Scanner 2-6

Initialization 2-7

Connecting the Scanner (SCSI) to Your Computer 2-8

 Understanding SCSI connections 2-9

 Setting the SCSI ID number 2-10

 Setting the terminator switch 2-12

 Connecting the scanner 2-13

 Power-on sequence 2-15

 Power-off sequence 2-16

Connecting the Scanner (USB) to Your Computer 2-16

 Understanding USB connections 2-17

 Connecting the scanner 2-18

Installing the Scanner Software 2-19

Choosing a Place for the Scanner

Follow the guidelines below when selecting a location for your scanner:

- ❑ Place the scanner on a flat, stable surface. The scanner will not operate properly if it is tilted at an angle.
- ❑ Place the scanner close enough to the computer for the interface cable to reach it easily.
- ❑ Place the scanner near a wall outlet where the power cord can be easily unplugged.

Note for French-speaking users:

Placez le scanner près d'une prise de courant où la fiche peut-être débranchée facilement.

- ❑ Allow space behind the scanner for the cables, and space above the scanner so that you can fully raise the document cover.

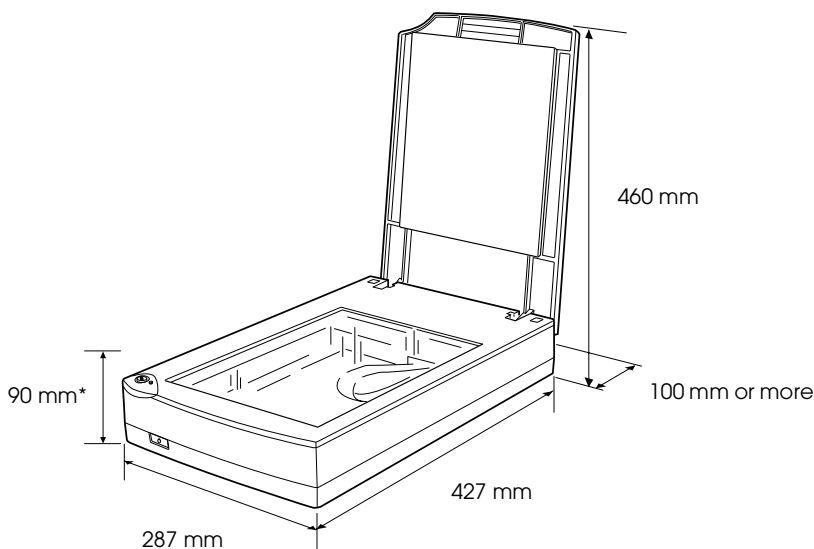

* When document cover is closed.

- Keep the scanner away from high temperatures, humidity and excessive dirt or dust. Also avoid using or storing the scanner in places subject to rapid changes of temperature and humidity.
- Keep the scanner away from direct sunlight and strong light sources.
- Avoid places subject to shocks and vibrations.

Installing a SCSI Interface Board

For Perfection 1200S model users only.

Unless your computer already has a SCSI board installed, you need to install a SCSI board and SCSI software before installing the scanner driver and software applications.

If you have a Macintosh that has a SCSI interface or if you already have a SCSI board installed in your PC or Macintosh, go to the next section.

Note:

For additional information, see the installation guide that comes with your SCSI board.

1. Turn off the computer and any peripheral devices. Unplug any power cords, then disconnect all cables from the back panel of your computer.
2. Remove the cover from your computer.



Caution:

Static electricity can damage electronic components. Discharge static electricity by touching the metal frame of your computer before handling the interface board or any of the computer's circuit boards.

3. Insert the interface board into an appropriate expansion slot, then secure it with the retaining screw.
4. Replace the computer cover and reconnect all cables.

Releasing the Transportation Lock

Before connecting the scanner to a power source, you must release the transportation lock.

1. Place the scanner on a flat, stable surface with the back facing you.
2. Turn the transportation lock on the right side to the unlocked position using a coin or similar object, as shown below.

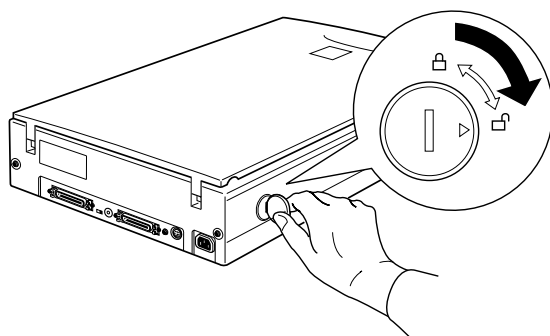

Note:

- ❑ *When you cannot turn the transportation lock because of excessive resistance, turn the scanner on, then, after the operate light starts flashing red, turn the scanner off, and try again. See the next section to turn on the scanner.*
- ❑ *Return the transportation lock to the locked position when transporting the scanner.*

Plugging in the Scanner

1. Make sure that the scanner is turned off. The scanner is off when the  operate button is not pushed in beyond the surface of the front panel.

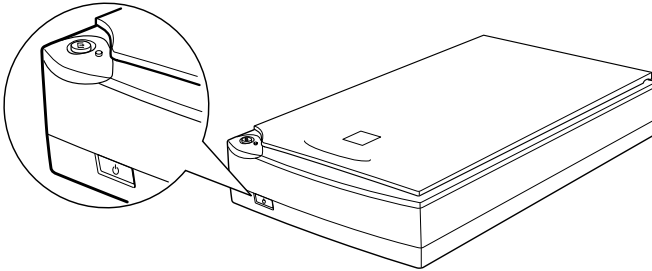

2. If the power cord is not attached to the scanner, connect it to the AC inlet on the back of the scanner, and plug the other end into a properly grounded electrical outlet.

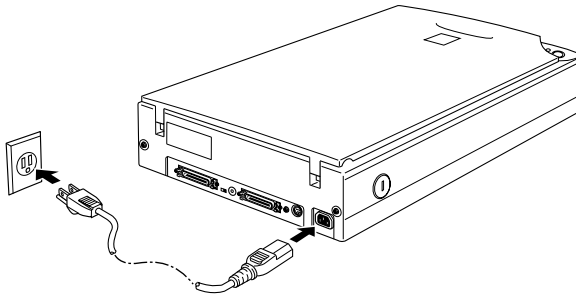

Caution:

It is not possible to change the scanner's voltage. If the label on the back of the scanner does not show the correct voltage for your country, contact your dealer. Do not plug in the power cord.

Initialization

2

Before connecting the scanner to your computer, follow the steps below to make sure that the scanner is operating properly.

1. Open the document cover so you can see the operation of the scanner during initialization (startup).
2. Turn on the scanner by pressing the  operate button. The operate light starts flashing.
3. Make sure the fluorescent lamp on the carriage flashes, and the carriage moves slightly.

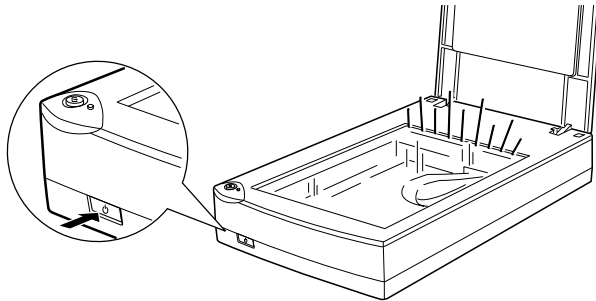

4. The operate light stays on, meaning the scanner has completed initialization.
5. Turn off the scanner.

If the scanner does not work as described, make sure the power cord is firmly plugged in and that you have released the transportation lock, then try again.



Caution:

Whenever you turn off the scanner, wait at least 10 seconds before turning it back on. Rapidly turning the scanner on and off can damage the scanner.

Note:

When the scanner is ready, the fluorescent lamp will also stay on, but the scanner will turn off the fluorescent lamp if it does not receive any commands from computer within 14 minutes.

Connecting the Scanner (SCSI) to Your Computer

For instructions on connecting your SCSI model scanner to your computer, read this section.

For PC users:

Unless your PC already has a SCSI board installed, you need to install the one that comes with your scanner, along with SCSI driver software. Install the SCSI board according to the directions included with it. Also see "Installing a SCSI Interface Board" on page 2-4.

If your PC has a SCSI board up and running, connect the scanner as described in the next section.

Note:

- ❑ *You will need to install the SCSI driver that is normally included with Windows 95, 98, or NT (see your system documentation for instructions), or the driver described in the SCSI board installation documentation.*
- ❑ *You can update the SCSI driver already installed on your system by installing EZ-SCSI included in your Scanner Software CD-ROM. Refer to the readme file for EZ-SCSI for further information.*

For Macintosh users:

Your Macintosh may or may not have SCSI ports, depending on which model you own. If you have a new Power Macintosh G3, you need to install the SCSI board and driver that came with your scanner by following the included instructions. Also, see “Installing a SCSI Interface Board” on page 2-4. The SCSI driver for the SCSI board that comes with your scanner is included in your Scanner Software CD-ROM. Refer to the README FIRST for further information. Follow the directions below to connect your scanner and computer.

Note:

The latest driver may be available for download from the Web site of the SCSI board manufacturer.

Understanding SCSI connections

Read the following sections to determine how to set up your SCSI devices and whether you need any optional SCSI cables.

Daisy Chain

The SCSI interface allows you to connect up to seven devices (such as a scanner, hard disk, CD-ROM, and so on) to the computer, in what is called a “daisy chain” arrangement. Only the first SCSI device in a daisy chain is connected to the computer; each of the other devices is connected to another SCSI device.

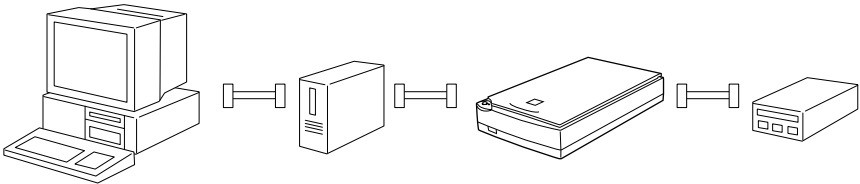

SCSI Cables

You may need to purchase SCSI cables before setting up your SCSI daisy chain. Be sure the SCSI cable connectors are suitable for your hardware, depending on the maker of your SCSI device and SCSI interface board.

SCSI ID and terminator

Each device has a SCSI ID number: the computer is usually number 7, and each of the other devices must have a different number between 0 and 6. Also, the first device and the last device in the chain (not including the computer) must have a terminator. No other device can have a terminator, or if a terminator does exist, it must be turned off or removed.

Setting the SCSI ID number

The scanner's default SCSI ID number is 2.

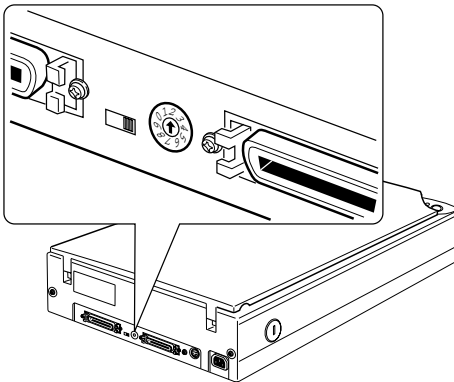

The SCSI ID rotary switch is located at the rear of the scanner.

If you add the scanner to a system in which one of your SCSI devices already has a SCSI ID of 2, change the ID number to an unused number using the rotary switch. See the table below as a guide.

ID	Availability	Description
0	Not available for Macintosh	Used for hard disk
	Not recommended for Windows	Usually used for hard disk
1	Not recommended	Usually used for hard disk
2		Factory setting of the scanner
3		Not available if your Macintosh has a built-in CD-ROM
4		
5		
6		
7	Not available for Macintosh	Always used for the Macintosh itself
	May not be available for Windows	Usually used for the SCSI board
8,9	Not available	Never selected*

* Scanner will not work if selected.



Caution:

Do not set the SCSI ID to an ID number that is already assigned to another device otherwise the computer, scanner, and other devices will not operate properly.

Setting the terminator switch

The scanner has a built-in terminator, which allows SCSI devices to communicate properly with each other. You may need to change the terminator switch setting according to your computer system.

Note:

Do not use an external terminator.

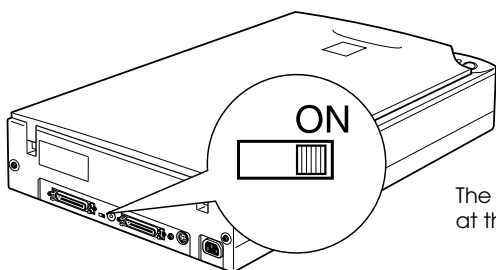

The terminator switch is located at the rear of the scanner.

Only the scanner is connected

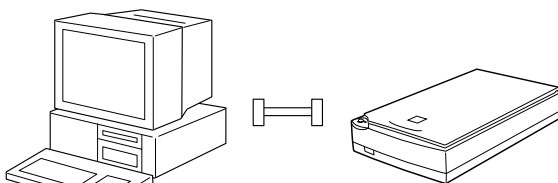

terminator on

The scanner is the last device in the daisy chain

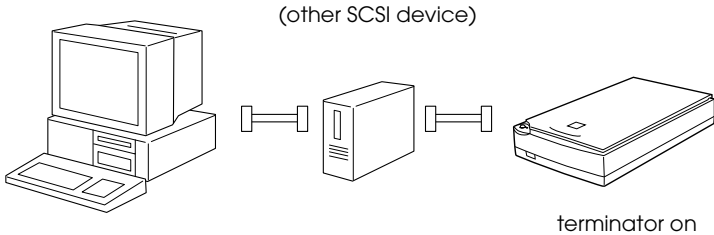

The scanner is in the middle of the daisy chain

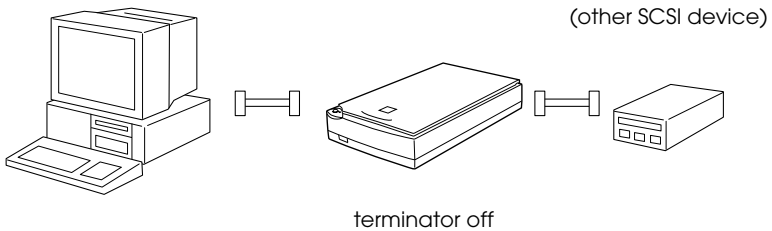

Connecting the scanner

Connect the scanner to your computer or to another SCSI device as follows:

Note:

The combination of 50-pin and 25-pin connectors you need varies depending on the maker of your SCSI device and SCSI interface board.

1. Make sure the scanner, computer, and all other SCSI devices are turned off and unplugged from the power source.



Caution:

Do not connect the scanner to the computer or other devices while they are turned on as damage may occur.

2. Connect one end of the interface cable to one of the scanner SCSI connectors until the locks on both sides snap in.

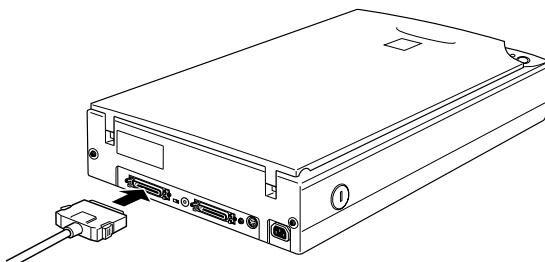

Note:

- ❑ *To connect the scanner to a SCSI device other than the computer, the length of cable in the daisy chain must not exceed 6 meters; otherwise the system may not work properly.*
 - ❑ *To connect the scanner to a PC using SCSI-2, the length of the cable must not exceed 3 meters.*
3. Connect the other end of the cable to the SCSI port of your computer or another SCSI device.

Note:

The SCSI port on the Macintosh is the larger port with the SCSI icon over it.

4. Plug in the power cords of your computer, scanner, and other external SCSI devices.

Note:

Before turning on your system, be sure to read "Power-on sequence" following.

Power-on sequence

Keep the following in mind every time you turn on your computer and SCSI devices, including the scanner.

- ❑ Be sure to turn on the SCSI device which is connected at the farthest end of the daisy chain first, then the second farthest and so on, until finally your computer. If you attempt to use a SCSI device which has been turned on after the computer, it may not work properly, or the computer may not work properly.
- ❑ **For Windows 95 or 98 users:**
The first time you turn on the computer after turning on the scanner, one of the following dialog boxes may appear.



Windows 95



Windows 98

If you see one of these, follow the installation instructions in Chapter 3, then see “Power-off sequence” following.

Power-off sequence

Keep the following in mind every time you turn off your computer and SCSI devices.

- ❑ When you are finished using your system, turn off your computer first, then the scanner and other SCSI devices in reverse order of the power-on sequence.
- ❑ While using your computer, do not turn off any SCSI device which has a terminator that is active (on).
- ❑ Do not turn the scanner off and back on while using your computer, otherwise the scanner may not work properly.

When the connection is complete, you need to install the scanner software. See Chapter 3 of this guide.

Connecting the Scanner (USB) to Your Computer

Your PC must be preinstalled with Windows 98, and have a working USB port.

Your Apple Macintosh G3 or iMac computer must be running system 8.5 or later, or system 8.1 with iMac Update1.0 and have a working USB port.

Note:

If you connect your scanner through more than one hub, your system may not work properly. In this case, try connecting the scanner directly to the computer's USB port. Also, your system may not work properly if you use a USB cable other than that supplied by EPSON.

Understanding USB connections

USB Cables

USB cables enable you to connect or remove peripherals to and from your computer easily, without having to shut down and restart the system each time a peripheral is plugged in or unplugged. You do not have to set an ID number or a terminator.

Note:

Do not connect or disconnect USB cables when the scanner is in use.

USB cables have 2 different connectors at each end.

Type A connects to your computer.

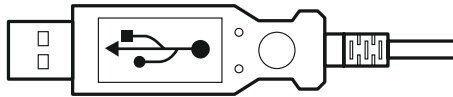

Type B connects to your scanner.

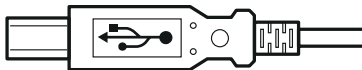

USB hub

You can also use a USB hub, allowing you to increase the number of USB ports and therefore connect several peripherals.

Connecting the scanner

To connect the scanner to your computer or USB hub:

1. Connect one end of the cable (Type B) to the USB port on the back of the scanner.

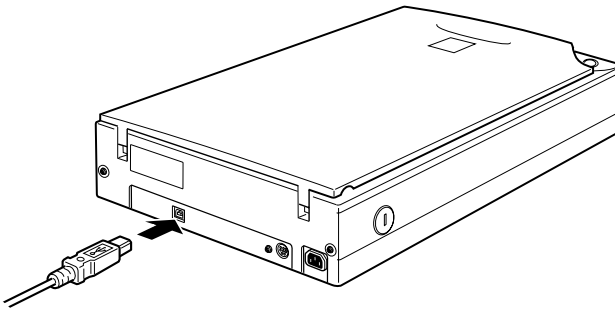
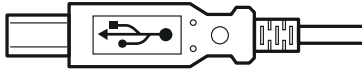

2. Connect the other end of the cable (Type A) to the USB port on your computer, or USB hub.

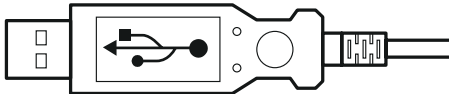

Note:

- ❑ *USB cables enable you to connect the scanner whether your computer is on or off. If you connect the scanner while your computer is on, the “Add New Hardware Wizard” dialog box (Windows) or a message telling you that the scanner driver needs to be installed (Macintosh) will appear. When this happens, follow the instructions in Chapter 3, then install the software.*

- ❑ *Connect the USB cable to your computer, then install or start the scanner software. Do not connect or disconnect the USB cable while the scanner software is open.*

Installing the Scanner Software

After setting up the scanner as described above, you need to install the scanner software before you use the scanner to scan documents. For details on setting up the scanning software, see the next chapter.

Chapter 3

Installing the Software

System Requirements	3-2
For PCs	3-2
For Macintosh computers and SCSI model users	3-3
For Macintosh computers and USB model users	3-4
Installing the Scanner Software for Windows	3-5
For Windows 98 users	3-5
For Windows 95 and Windows NT 4.0 users	3-15
Upgrading from Windows 95 to Windows 98	3-21
Installing the Scanner Software for Macintosh	3-23
Calibrating Your Screen	3-25

System Requirements

Before installing the scanner software, make sure that your system meets the following requirements.

For PCs

For Windows and SCSI model users

Scanner:	EPSON Perfection 1200S
System:	Microsoft® Windows® 95, Windows® 98, or Windows NT® 4.0
Interface:	Adaptec® SCSI adapter
Display:	VGA or higher resolution monitor 640 × 480 screen resolution (800 × 600 or higher recommended), and 256 color (65,000 color or higher recommended)

Note:

Color and tone reproduction are subject to the display capability of your computer system, including the video card, display monitor, and software. See the product documentation for details.

For Windows and USB model users

Scanner:	EPSON Perfection 1200U/Perfection 1200PHOTO
System:	Microsoft® Windows® 98 preinstalled
Interface:	The computer's USB port (TYPE A receptacle)
Display:	VGA or higher resolution monitor 640 × 480 screen resolution (800 × 600 or higher recommended), and 256 color (65,000 color or higher recommended)

Note:

Color and tone reproduction are subject to the display capability of your computer system, including the video card, display monitor, and software. See the product documentation for details.

For Macintosh computers and SCSI model users

Scanner:	EPSON Perfection 1200S
System:	Apple® Macintosh® with a PowerPC processor (except PowerBook 100) running system 7.5.x or later
Interface:	SCSI adapter

Note:

You cannot use a serial interface.

Display: Color Monitor, 640 × 480 screen resolution (or higher recommended), and 256 color (32,000 color or higher recommended)

Note:

Color and tone reproduction are subject to the display capability of your computer system, including the video card, display monitor, and software. See the product documentation for details.

For Macintosh computers and USB model users

Scanner: EPSON Perfection 1200U/Perfection 1200PHOTO

System: Apple Power Macintosh G3 running AppleSystem 8.5 or later

iMac running AppleSystem 8.5 or later, or AppleSystem 8.1 with iMac Update 1.0

Interface: USB port

Note:

You cannot use a serial interface.

Display: Color Monitor, 640 × 480 screen resolution (or higher recommended), and 256 color (32,000 color or higher recommended)

Note:

Color and tone reproduction are subject to the display capability of your computer system, including the video card, display monitor, and software. See the product documentation for details.

Installing the Scanner Software for Windows

After connecting the scanner to your computer, install the scanner software from the CD-ROM. The installation steps differ depending on the version of Windows.

Find instructions for Windows 98 users in this section. Instructions for Windows 95 and NT 4.0 users can be found in “For Windows 95 and Windows NT 4.0 users” on page 3-15.

3

For Windows 98 users

The following will describe installing the software for SCSI users, USB users should go to page 3-10.

SCSI users

Note:

If you are currently using Windows 95 and the scanner software is already installed, but you are upgrading from Windows 95 to 98, first uninstall EPSON TWAIN while running Windows 95. Then reinstall EPSON TWAIN as described in step 1 below on Windows 98. When uninstalling EPSON TWAIN see page 3-21 .

1. Make sure that the scanner is turned on.
2. Turn on the computer, and start Windows.

3. When the dialog box below appears, insert the scanner software CD in the CD-ROM drive, then click Next.



4. Select the Search for the best driver for your device option, then click Next.



5. Make sure the Specify a location check box is selected, then browse and select or type in the CD-ROM drive letter, Epson folder, the folder of your preferred language, and Win98 folder as the location, as shown below, and click Next.



6. Follow the instructions on the screen. You may be asked to insert the Windows 98 CD-ROM.



Make sure that the correct CD-ROM drive letter and the Win98 folder are specified in the Copy files from: box as shown below.

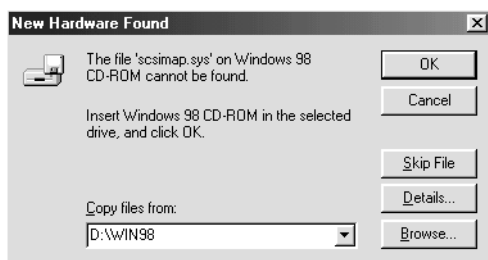

7. The EPSON Screen Calibration utility automatically starts. Follow the instructions on the screen. For details, see page 3-25.

Note:

If the EPSON Screen Calibration utility doesn't start automatically, see page 3-25 to calibrate your screen after installing the scanner software.

8. When the following dialog box is displayed, click Finish.



This completes the EPSON TWAIN installation, next you will install utility and application software from the CD-ROM.

1. Double-click the My Computer icon.
2. Double-click the CD-ROM drive icon. A dialog box asking for your preferred language appears on your screen. If no dialog box appears, click the Cdsetup.exe icon.
3. Select your preferred language and click OK.
4. You will see the following dialog box. Click Add Software.

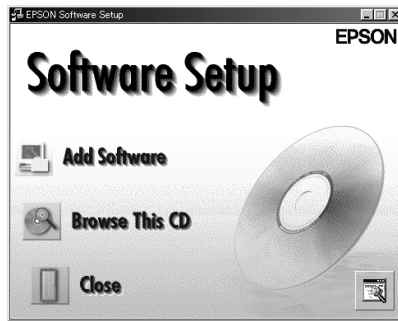

5. You will see the list of software in the list box. Click to select the names of the software you want to install in your PC. Descriptions of the software can be found in the software documentation, or on the CD-ROMs that come with your scanner. Make sure PageManager for EPSON is selected to be installed.
6. Click OK. Then follow the instructions on the screen.

The setup program installs the selected software.

Note:

- ❑ *If folders for the applications on the CD-ROM contain README files, double-click and read them as they contain up-to-date information regarding the software.*

- ❑ You will find the *Scanners and Cameras* icon shown below in the Control Panel after EPSON TWAIN is installed.

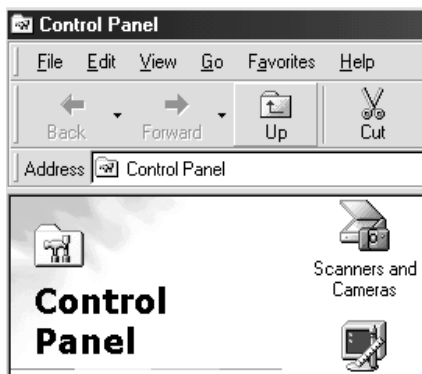

USB users

1. Make sure that the scanner is turned on.
2. Turn on the computer, and start Windows.

Note:

You do not necessarily have to follow steps 1 and 2 above in that order. USB cables enable you to connect or remove the scanner to or from your computer easily, regardless of whether your computer and/or scanner are on or off.

3. When the dialog box below appears, insert the scanner software CD in the CD-ROM drive, then click Next.



4. Select the Search for the best driver for your device option, then click Next.



5. Make sure the Specify a location check box is selected, then browse and select or type in the CD-ROM drive letter, Epson folder, the folder of your preferred language, and Win98 folder as the location, as shown below, and click Next.



6. Follow the instructions on the screen. Depending on your system, you may be asked to insert the Windows 98 CD-ROM.

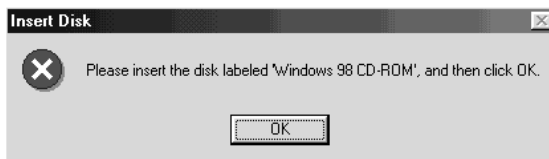

Make sure that the correct CD-ROM drive letter and the Win98 folder are specified in the Copy files from: box as shown below.

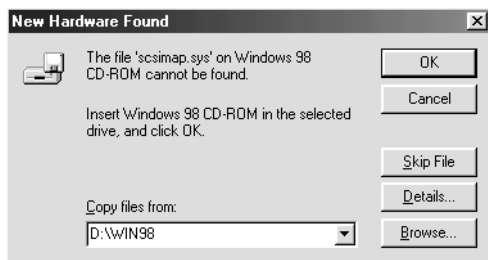

7. The EPSON Screen Calibration utility automatically starts. Follow the instructions on the screen. For details, see page 3-25.

Note:

If the EPSON Screen Calibration utility doesn't start automatically after installing the scanner software, see page 3-25 to calibrate your screen.

8. When the following dialog box is displayed, click Finish.



This completes the EPSON TWAIN installation, next you will install utility and application software from the CD-ROM.

1. Double-click the My Computer icon.
2. Double-click the CD-ROM drive icon. A dialog box asking for your preferred language appears on your screen. If no dialog box appears, click the Cdsetup.exe icon.
3. Select your preferred language and click OK.
4. You will see the following dialog box. Click Add Software.

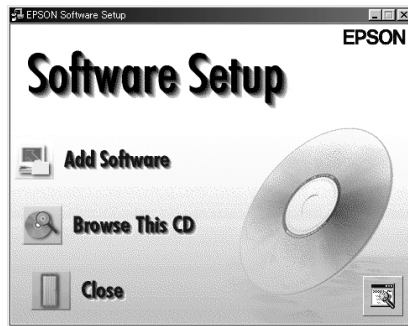

5. You will see the list of software in the list box. Click to select the names of the software you want to install in your PC. Make sure PageManager for EPSON is selected to be installed. Descriptions of the software can be found in the software documentation, or on the CD-ROMs that come with your scanner.
6. Click OK. Then follow the instructions on the screen.

The setup program installs the selected software.

Note:

- ❑ *If folders for the applications on the CD-ROM contain README files, double-click and read them as they contain up-to-date information regarding the software.*

- ❑ You will find the *Scanners and Cameras* icon shown below in the *Control Panel* after EPSON TWAIN is installed.

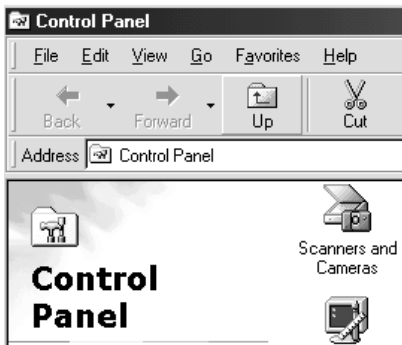

For Windows 95 and Windows NT 4.0 users

1. Make sure that the scanner is turned on.
2. Turn on the computer, and start Windows.

If you are using Windows NT 4.0, insert the scanner software CD in the CD-ROM drive. Go to step 3.

If you are using Windows 95, one of the following dialog boxes will appear.

- ❑ If the dialog box below appears, insert the scanner software CD in the CD-ROM drive.



Select Driver from disk provided by hardware manufacturer, then click OK, and Browse.

Select the CD-ROM drive, Epson folder, the folder of your preferred language, and Win95 folder, then click OK. Go to step 3.

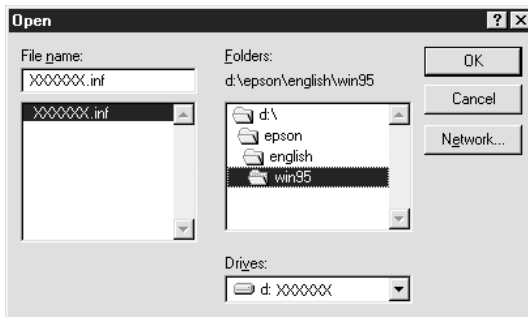

- ❑ If the dialog box below appears, insert the scanner software CD in the CD-ROM drive, then click Next.



When you are asked for the drive and folder, select the CD-ROM drive, Epson folder, your language preference, and Win95 folder. An example is shown below.

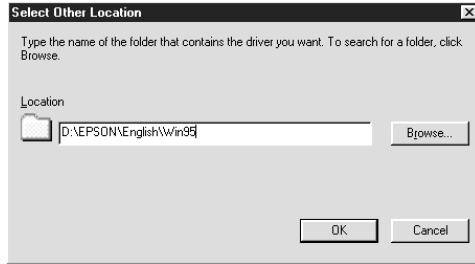

When the following dialog box or similar appears, click Finish.



3. Double-click the My Computer icon.
4. Double-click the CD-ROM drive icon. A dialog box asking your preferred language appears on your monitor. If no dialog box appears, click the Cdsetup.exe icon.
5. Select your preferred language and click OK.
6. You will see the following dialog box. Click Add Software.

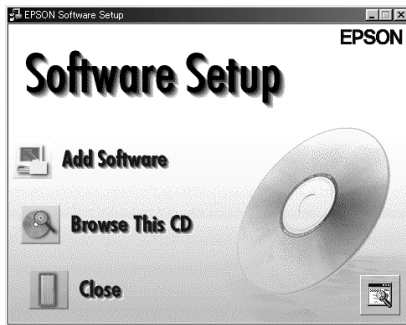

7. You will see the list of software in the list box. Click to select the names of the software you want to install in your PC. Make sure EPSON TWAIN and PageManager for EPSON are selected. Descriptions of the software can be found in Chapter 4, or on the CD-ROMs that come with your scanner.
8. Click OK. Then follow the instructions on the screen.

The setup program installs EPSON TWAIN, EPSON Scanner Monitor and PageManager for EPSON.

9. After EPSON TWAIN is installed, the EPSON TWAIN 4 dialog box appears.

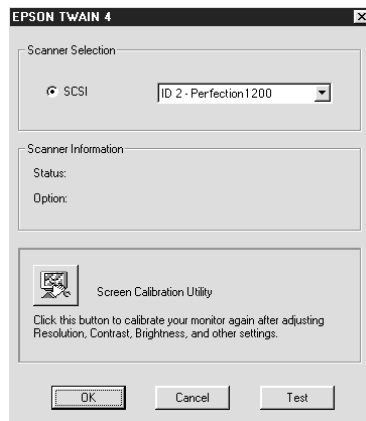

10. Make sure that SCSI is selected and your EPSON scanner appears in the Scanner Selection list. If not, see Chapter 7, “Maintenance and Troubleshooting.”

11. Click **Test** to check the connection. If everything is properly installed and connected, **Status: Device Ready** appears under **Scanner Information** in the dialog box.

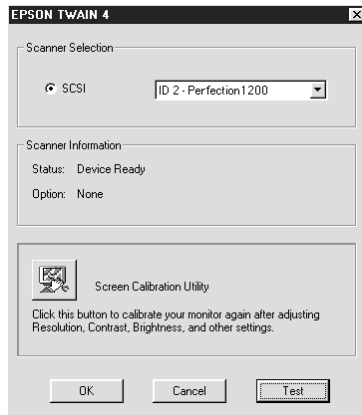

If the “Device Ready” message does not appear, see Chapter 7, “Maintenance and Troubleshooting.”

12. Click **OK** to close the EPSON TWAIN 4 dialog box.

The EPSON Screen Calibration utility automatically starts. Go to page 3-25.

Upgrading from Windows 95 to Windows 98

Before you upgrade from a Windows 95 operating system to Windows 98, you need to uninstall EPSON TWAIN. Follow the steps below.

1. Click the EPSON Scanner Monitor icon in the task bar and select Close to close EPSON Scanner Monitor.

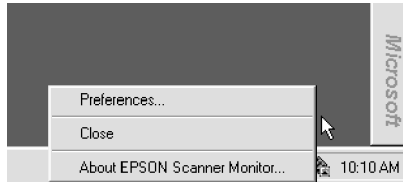

2. Click the Start button, highlight Settings, and then select Control Panel.

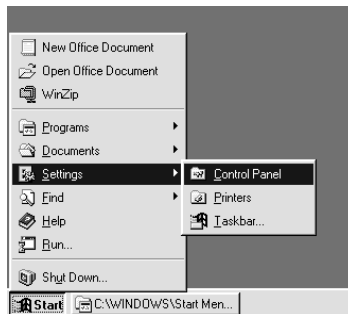

3. Double-click the Add/Remove Programs icon. Select EPSON TWAIN 4 and click the Add/Remove button. Then follow the instructions on the screen.

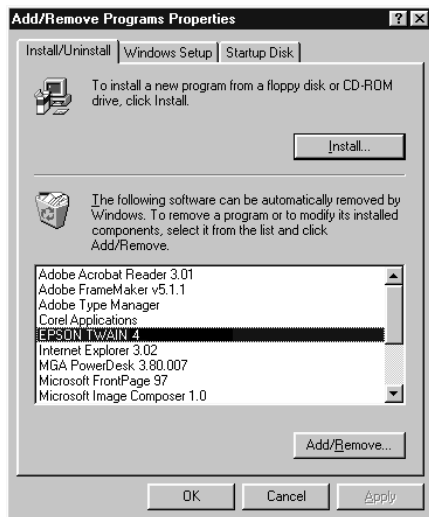

After you uninstall EPSON TWAIN, upgrade to Windows 98, then install EPSON scanner software as described on page 3-5.

Installing the Scanner Software for Macintosh

After connecting the scanner to your Macintosh computer, install the EPSON scanner software; EPSON TWAIN, EPSON Scanner Monitor, PageManager for EPSON and other application software from the CD-ROM. Follow the steps below.

1. Make sure your scanner is on. Then turn on the computer.
2. Insert the CD in the CD-ROM drive.

3

For SCSI users

3. Double-click the EPSON TWAIN folder.

The EPSON TWAIN folder contains multiple-language versions of the software. Double-click the folder of your preferred language.

4. Double-click the EPSON TWAIN 4 Installer icon.



EPSON TWAIN 4 Installer

For USB users

3. Double-click the EPSON TWAIN USB folder.

The EPSON TWAIN USB folder contains multiple-language versions of the software. Double-click the folder of your preferred language.

4. Double-click the EPSON TWAIN 4U Installer icon.



EPSON TWAIN 4U Installer

5. The installer software shows a dialog box. Click Install in the dialog box that appears, and follow the instructions on the screen.

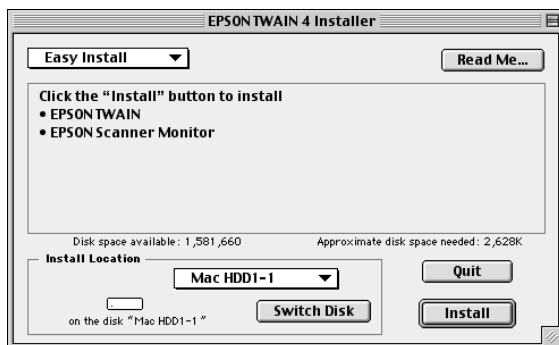

When you have finished the entire installation, the EPSON Screen Calibration utility automatically starts. Go to page 3-25 for instructions, then continue from step 6 below to install other software.

6. Double-click the folder that contains the software you want to install.

The Software folder contains multiple-language versions of the software. Double-click the folder of your preferred language.

7. Double-click the installer icon to start the installation program. Then follow the instructions on the screen.

Calibrating Your Screen

You must calibrate your screen and scanner to reproduce images identical to the originals.

Note for Windows 98 and Macintosh users:

The introductory Screen Calibration dialog box will not appear. Follow the instructions from step 2 below to calibrate your screen.

During the EPSON scanner software installation on Windows, the following dialog box appears.



1. Click Next.

2. In the following or similar dialog box, move the slider to the right or left until the two shades of the gray horizontal stripes match.

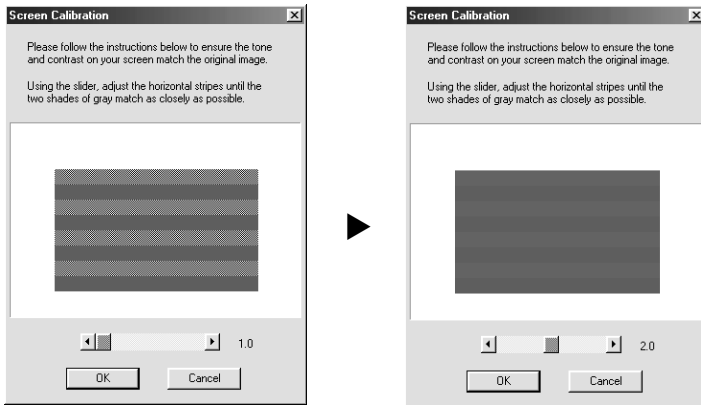

Note:

View the screen from a distance. The gray stripes will not perfectly blend together; however, try to make the two tones match as closely as possible.

3. Click OK to register the calibration setting.
4. The message Setup is complete appears. Click OK.

You will not need to change the screen calibration again so long as you continue to use the same display.

Chapter 4

Using Your Scanner

Scanning Procedure.	4-2
Placing a Document on the Scanner	4-2
Removing the Cover for Thick or Large Documents	4-6
Starting EPSON TWAIN	4-8
Scanning an Image	4-9
Scanning From the Easy Menu.	4-10
Scanning From the Advanced Menu.	4-14
Saving the Scanned Image	4-18
Scanning by Pressing the Start button	4-19



Scanning Procedure

This chapter shows you how the scanner operates. The basic procedure for scanning is as follows:

1. Turn on the scanner. (Keep in mind the “Power-on sequence” on page 2-15.)
2. Place the document you want to scan on the document table. (This is described in detail in the next section.)
3. Run the scanner software and scan. (See page 4-8 for details on scanning.)

Placing a Document on the Scanner

Before scanning a document, remember to respect the rights of copyright owners. Do not scan published text or images without first checking the copyright status.

1. Turn on the scanner by pressing the  operate button. The operate light starts flashing.

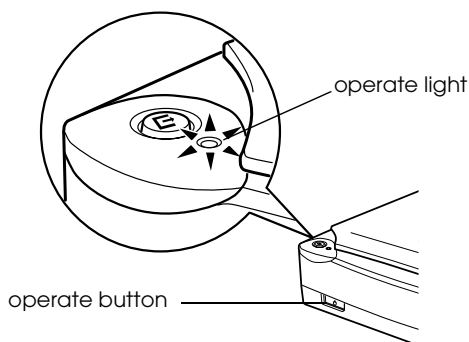

2. Turn on the computer and make sure that the scanner's operate light is on, but has stopped flashing.
3. Open the document cover.

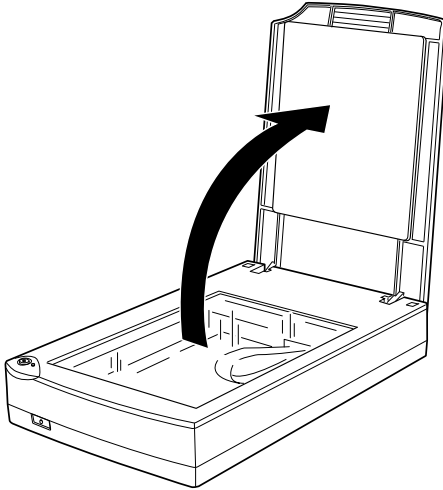

4. Place the document on the document table, with the side to be scanned facing down. Make sure that the document is carefully aligned.

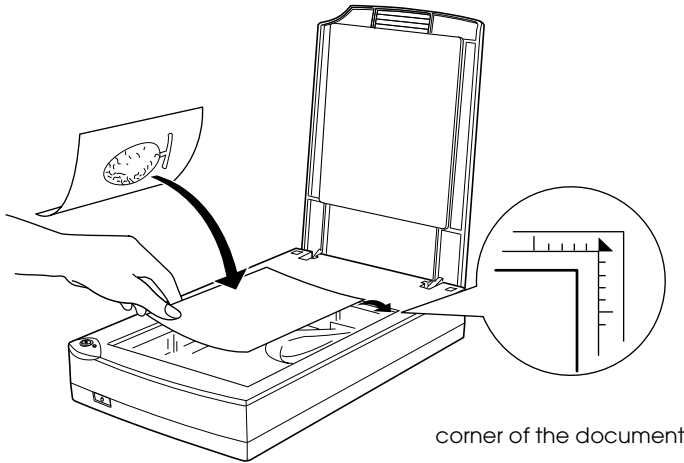

Note:

An area approximately 3mm in from both horizontal and vertical edges of the document table glass will not be scanned.

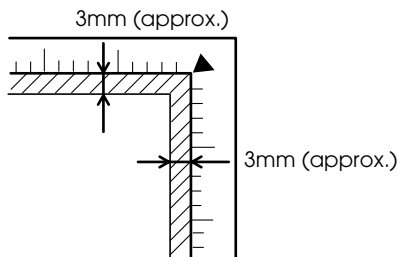

5. Close the document cover gently so that the document does not move.

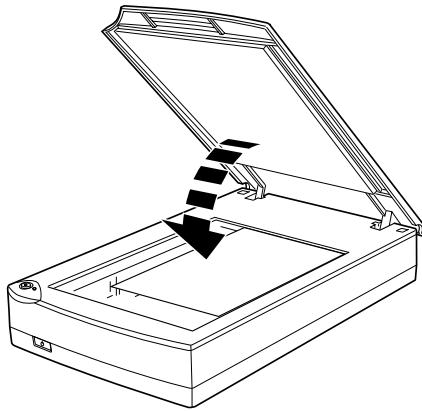

Note:

- ❑ *Make sure the document is flat against the glass surface, otherwise the image will appear fuzzy and out of focus. Also be sure to close the document cover to prevent interference from external light.*
 - ❑ *Always keep the document table clean. See “Cleaning the Scanner” in Chapter 7.*
 - ❑ *Do not leave photographs on the document table for an extended period of time as they may stick to the glass.*
 - ❑ *Do not place heavy objects on top of the scanner.*
6. Start your scanner software, and follow scanning instructions described later in this chapter or your scanner software reference guide.

Removing the Cover for Thick or Large Documents

For thick materials or documents that are larger than the document table, remove the document cover.

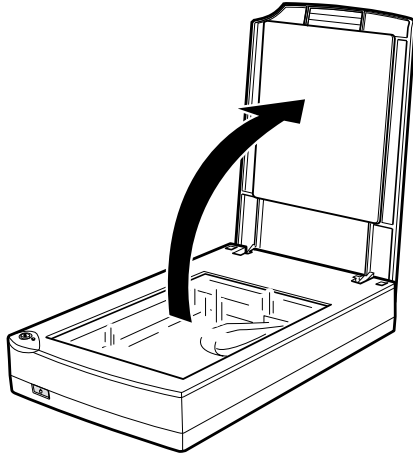

First, open the document cover.

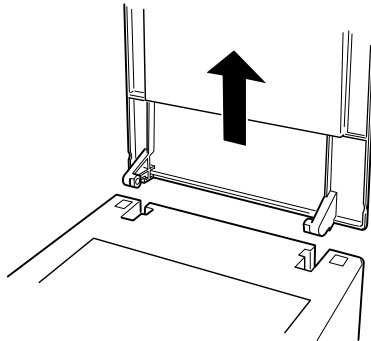

Then, pull the cover straight up.

Note:

When scanning with the cover removed, do not leave any area of the document table exposed to prevent interference from external light.

When you are finished scanning, replace the document cover in the reverse order that you removed it.

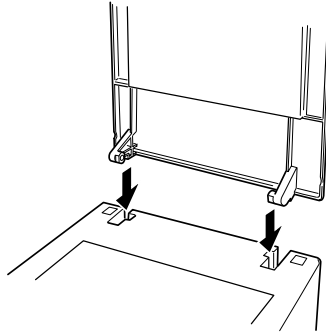

Starting EPSON TWAIN

There are two ways to scan; with an application that supports TWAIN, or with the ⚡ Start button and preassigned application software.

If you ..

- ❑ use an application that supports EPSON TWAIN to scan, open your application (see “Starting EPSON TWAIN through your application software” below).
- ❑ want to scan an image directly to your application without opening EPSON TWAIN or the TWAIN-compliant application every time, setup the ⚡ Start button and the application to work with (see Chapter 5 “Using the Start Button”). Then simply press the ⚡ Start button.

Note:

Even if your application supports TWAIN, some features of EPSON TWAIN may not be available depending on the application software.

Starting EPSON TWAIN through your application software

Application programs that support the scanning interface standard TWAIN, allow you to scan images while an application is running. To verify whether your application is compatible with TWAIN, see your application documentation.

How you should open EPSON TWAIN and scan varies depending on the application. Read the following to find out how to access EPSON TWAIN.

1. Start your application. For example, Presto! PageManager for EPSON.
2. Select Select Source from the File menu, and then select EPSON TWAIN 4 on Windows and Macintosh (SCSI) users, or EPSON TWAIN 4U on Macintosh and USB users.

Note:

You usually need to perform this step only the first time you use the scanner with your application.

3. Choose Acquire from the File menu to open EPSON TWAIN.

To scan, see the next section.

Scanning an Image

When you start EPSON TWAIN through a TWAIN-compliant application, one of the following windows appears on the screen:

Note for Macintosh users:

Most illustrations shown in this chapter are for Windows, so they may vary from the actual dialog boxes that appear on your screen. You can use them for reference however, as almost all the settings and functions are the same.

Easy menu



Advanced menu

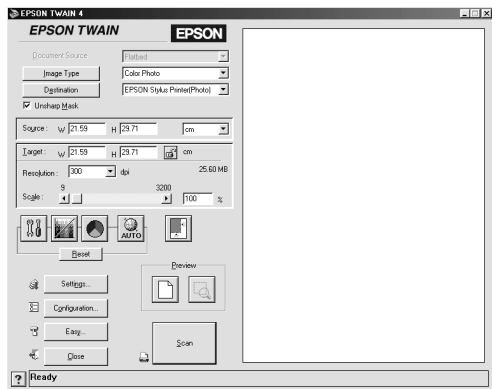

Clicking the Advanced button on the Easy menu, you can open the Advanced menu. To go back to the Easy Menu, click the Easy button on the Advanced menu.

The following sections give an overview of EPSON TWAIN.

Note:

Some settings may appear dimmed and cannot be selected because of your choice of settings.

Scanning From the Easy Menu

Easy menu

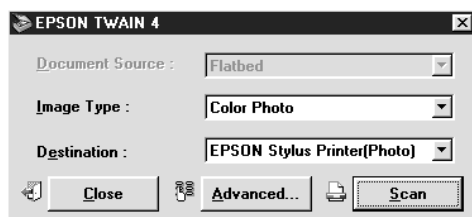

The Easy menu displays the minimum required settings only, allowing you to scan easily and quickly. Just select the relevant Document Source, Image Type, and Destination settings, then click Scan.

EPSON TWAIN automatically locates the target image on the scanner, adjusts the exposure, and starts scanning. See page 4-11 through 4-14 for details about Document Source, Image Type, and Destination settings.

Note:

- ❑ *You cannot scan an image that exceeds available memory or disk space. If you attempt to scan an image that is too large, an alert appears on the screen.*
- ❑ *Before you begin scanning, you should calibrate your screen. For details, see your Software Reference Guide.*
- ❑ *After an image is scanned, be sure to save it.*

Document Source

When using the document table of the scanner, leave the Document Source set to Flatbed. Other selections are available depending on what is installed. These are Auto Document Feeder (the optional Automatic Document Feeder), and TPU for Neg. Film or TPU for Pos. Film (for the Film Adapter optional with Perfection 1200S and Perfection 1200U, and included with Perfection 1200PHOTO).

Note:

Uninstalled options are not displayed.



Flatbed:

Select this setting to use the document table of the scanner.

Auto Document Feeder:

Select this setting to use the optional Automatic Document Feeder.

TPU for Neg. Film, TPU for Pos. Film:

Select one of these settings when using the Film Adapter. If you are scanning negative film, select TPU for Neg. Film, and if you are scanning positive film (or slides), select the TPU for Pos. Film setting.

Image Type

Use the Image Type list to select the type of image to be scanned.



The Image Type list provides the following predefined settings. Click the arrows on the right to view all of the available settings.

Color Photo:

24-bit Color, best quality

Color Photo De-screening:

24-bit Color, best quality, de-screening on, select this to remove moiré patterns automatically from scanned images. However, note it takes longer to scan images.

Note:

A moiré is a cross-hatch pattern that appears on scanned images when scanning printed material. It is a result of interference that occurs due to the difference between the pitches of the scanning and the halftone screens.

Black & White Photo:

8-bit Gray and best quality

Line Art:

Black and white, and draft quality

OCR:

Black and white, best quality, and Text Enhancement Technology

Copy & Fax:

Black and white, hard halftone, draft quality, and Auto Area Segmentation

Destination

Select the destination, or output device, where the scanned image is to be printed or displayed using the Destination list.

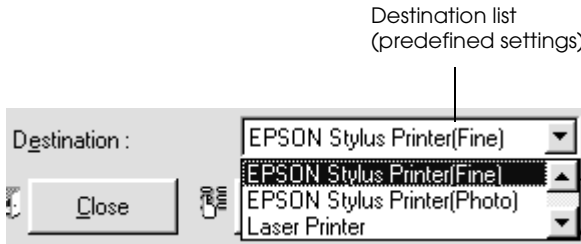

The Destination list provides the following predefined settings.

Screen/Web:

Suitable to display on screen

Fax:

Suitable for facsimile transmission

OCR:

For optical character recognition scanning

EPSON Stylus Printer (Fine or Photo):

If you are using an EPSON Stylus printer and are printing scanned images with the Economy, Normal, or Fine Print Quality settings in your printer software, selecting EPSON Stylus Printer (Fine) is recommended. If you are printing with the SuperFine or Photo Print Quality settings, select EPSON Stylus Printer (Photo).

Laser Printer:

Optimize for printing on a laser printer

Note:

The effects of the Destination settings cannot be viewed in the Preview window.

If you want greater choice with your settings, or want to make more settings, click Advanced to open the Advanced menu.

Scanning From the Advanced Menu

Advanced menu

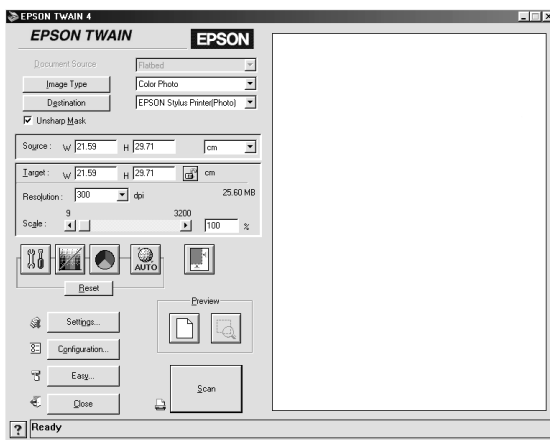

The Advanced menu allows you to make detailed settings viewing the effects on the images in the Preview window. You can set parameters for a setting or select special functions provided with EPSON TWAIN to attain the highest quality scanned images.

Note:

- ❑ *The online Software Reference Guide in the Scanner Software Reference Guide CD-ROM provides you with information on settings and functions.*
- ❑ *Online help also provides you with information on settings. Click ? to access help.*
- ❑ *You cannot scan an image that exceeds available memory or disk space. If you attempt to scan an image that is too large, an alert appears on the screen.*
- ❑ *Before you begin scanning, you should calibrate your screen. For details, see your Software Reference Guide.*
- ❑ *After an image is scanned, be sure to save it.*

Previewing images

Before you scan and save an image, you can preview it in the Preview window located on the right of the Advanced menu. Use the preview feature to check the results of your settings.

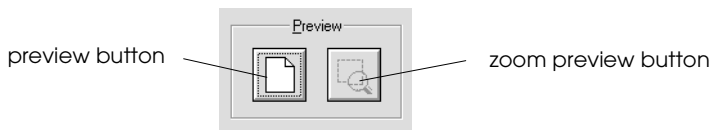

- ❑ To preview the entire image, click the preview button.

- ❑ To preview a part of the image that is already in the Preview window, click and drag the mouse over the area you want to see in detail, and click the zoom preview button.

Note:

- ❑ *You cannot preview an image that exceeds available memory or disk space. If you attempt to preview an image that is too large, an alert appears on the screen.*
- ❑ *When the mouse pointer is placed within the marquee (the frame of the selected image area), the mouse pointer changes to a hand icon. You can click and drag the marquee anywhere in the Preview window.*

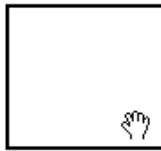

- ❑ *When the mouse pointer is placed on the edge of the marquee, it changes to an arrow allowing you to resize the marquee.*

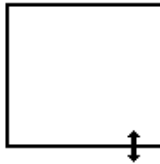

- ❑ *To remove or delete a marquee, double-click on the preview window.*

Modifying the preview image

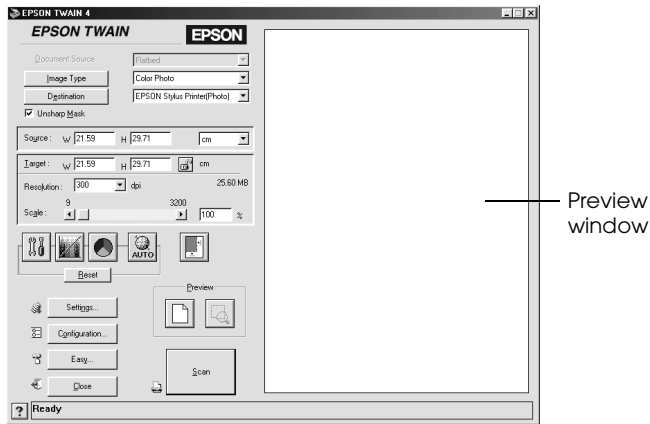

You can see the effects of the following settings in the preview image.

- Pixel Depth, Halftone, and Dropout in the Image Type dialog box
- Exposure, Gamma, Highlight, Shadow, and Threshold in the Image Controls dialog box
- Tone Correction in the Tone Correction dialog box
- Gray Balance Intensity, and Saturation in the Color Adjustment dialog box
- Auto Exposure

Note:

Although the image in the Preview window changes as you make settings, the settings do not affect the actual image until you scan, or rescan, the image.

Saving the Scanned Image

- ❑ To save a scanned image in your application, choose **SAVE** or **SAVE AS** from the File menu. For details, see your application documentation.
- ❑ To save a scanned image in PageManager for EPSON, follow the steps below.

Note:

Parenthesized words in the following steps apply to Macintosh users.

1. Choose **SAVE AS** from the File menu. The following dialog box appears on the screen.

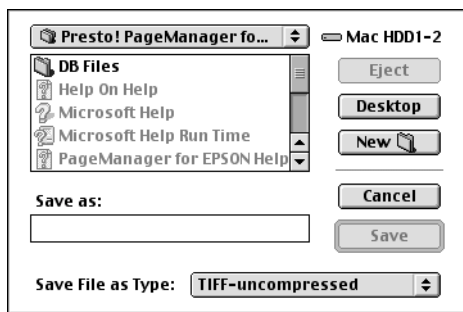
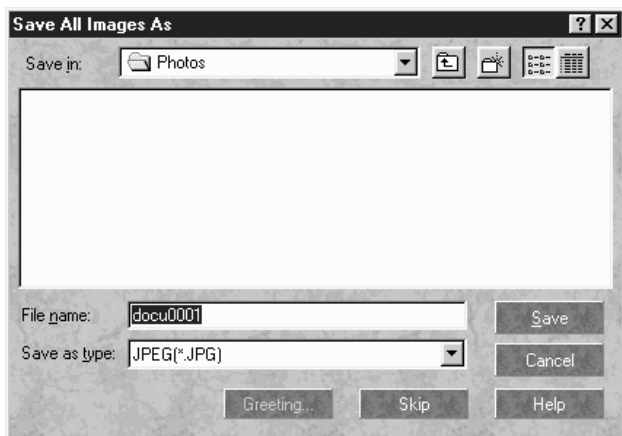

2. Select the folder where the image will be saved.
3. Type a filename for your image in the File Name (Save as) field.
4. Select the file format you want to save the image in from the Save as type field.
5. Click OK (Save).

Scanning by Pressing the Start button

You can open EPSON TWAIN, start scanning, and have the scanned image sent to a certain application, simply by pressing the  Start button on your scanner. To use this feature, you need to install PageManager for EPSON, or other Start button compatible software. The following occurs:

- ❑ Windows 98, or EPSON Scanner Monitor software on an operating system other than Windows 98, detects when the  Start button is pressed and sends information to the Start button compatible application, such as PageManager for EPSON.
- ❑ The Start button compatible application will automatically open EPSON TWAIN, scan the image and process it in the way the application is designed.

Note:

- ❑ *You need to setup the Start button compatible software before using this feature. See Chapter 5 and the documentation that comes with the application.*
- ❑ *The scanned image will be handled by the software to its maximum capability. For example, using PageManager for EPSON, you can send the scanned image to a printer to print, or convert your scanned OCR image to text format and paste it in a wordprocessing application—all by simply pressing the  Start button.*

Chapter 5

Using the Start Button

The Start Button Feature	5-2
PageManager for EPSON	5-2
Target applications in the Scan Buttons bar	5-2
Assigning an application to the Start button	5-3
Adding Applications to the Scan Buttons Bar	5-5
Registering new applications	5-6
Setting Up EPSON Scanner Monitor	5-8
Setting Up the Start Button Feature for Windows 98	5-12

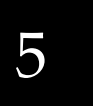



The Start Button Feature

The Start Button feature allows you to scan and send data to a target application with a single push of your scanner's  Start button. The following sections will help you set up your PageManager for EPSON and EPSON Scanner Monitor software, or Windows 98 system, so you can begin to use the Start Button feature.

Note for Windows 98 users:

The Start Button feature is supported by Windows 98, the EPSON Scanner Monitor software will not be installed onto Windows 98. See page 5-12 for instructions on setting up the Start Button feature.

PageManager for EPSON

PageManager allows you to scan and send data directly to an assigned application with a single push of your scanner's  Start button. You can also scan to any target application by simply clicking on the application icon in PageManager's Scan Buttons bar. This section will help you set up PageManager so you can begin to scan using the  Start button. For more detailed information on PageManager settings, see your PageManager documentation.

Note:

For information on PageManager installation, see Chapter 3.

Target applications in the Scan Buttons bar

When PageManager is started, the Scan Buttons bar will appear on your screen. The icons in this bar represent target applications or peripheral devices, such as a printer, that can be accessed by your scanner. This means that you can scan and send data directly to these applications or devices by clicking on their icons.

PageManager for EPSON also allows you to assign any one of the applications or devices on the Scan Buttons bar to the ⇄ Start button. This means that an image can be scanned and sent straight to your selected application with one simple push of the ⇄ Start button.



Note:

The application button showing the Start button icon represents the application that is assigned to the Start button.

Assigning an application to the Start button

To assign an application on the Scan Buttons bar to the ⇄ Start button, follow the steps below.

1. Select the Scan Buttons Setting from the File menu.



2. Click the Start Button Settings tab in the Scan Buttons Setting dialog box. The following dialog box appears.

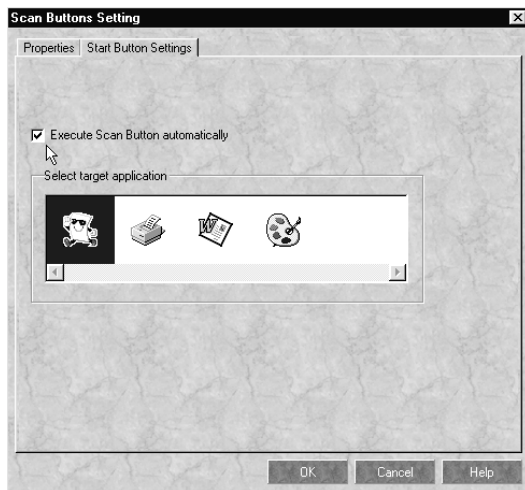

The icons in Select target application correspond to the icons in the Scan Buttons bar and represent the possible target devices and applications.



3. Select an application from the Select target application box and click OK.

The selected application is now assigned to the scanner's  Start button.

Execute Scan Button automatically check box

When this check box is selected, the assigned application will automatically open and the scanned image is sent to the application when you press the  Start button. When this check box is clear, no application is assigned to the  Start button and only the Scan Buttons bar will appear when the  Start button is pressed. Then you can select an application from the Scan Buttons bar.

Adding Applications to the Scan Buttons Bar

You can add applications appearing in the Application bar at the bottom of the PageManager window to the Scan Buttons bar. Follow the steps below.

1. Select Scan Buttons Setting from the File menu. You will see the following dialog box.

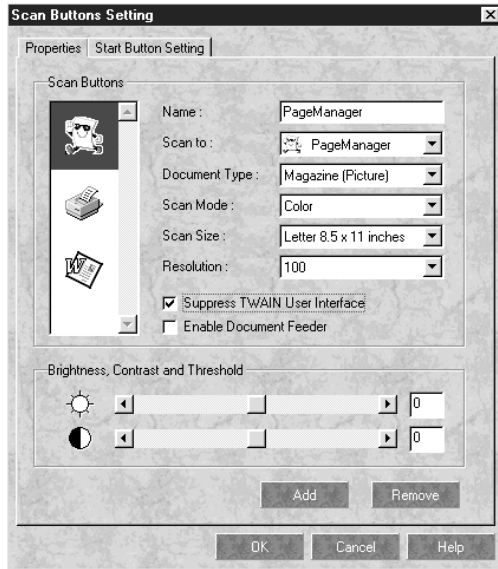

2. Specify the name of the setting in the Name box.
3. Click the arrow next to the Scan to box and select the application you want to add to the Scan Buttons bar.
4. Select the appropriate scanning settings (Document Type, Scan Mode, etc.) for the application from this dialog box and click Add. Then click OK.

The button of the selected application appears on the Scan Buttons bar.

To remove an application assigned to the Scan Buttons bar, select the application in the box on the left of the dialog box and click Remove. Then click OK.

Suppress TWAIN User Interface check box

When this check box is selected, the EPSON TWAIN dialog box does not appear when you scan, and the scanner works according to the settings in PageManager. When this check box is clear, the EPSON TWAIN dialog box appears when you scan, and the scanner works according to the settings in EPSON TWAIN.

Enable Document Feeder check box

When this check box is selected, the scanner feeds your documents through the Automatic Document Feeder. When this check box is clear, the scanner scans your documents from the document table.

Registering new applications

To add an application to Scan Buttons bar, you need to register the application. The registered applications will appear in the Scan to: box in the Scan Buttons Setting dialog box.

1. Select Application Setting from File menu and then select Register New Application.

The Register Application Wizard dialog box appears.

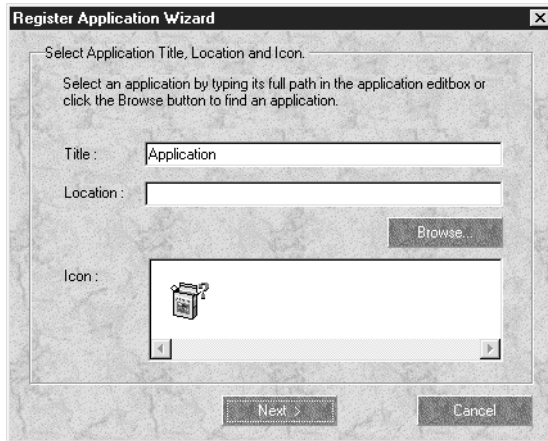

5

2. Specify the application's name, location and icon and click Next>.

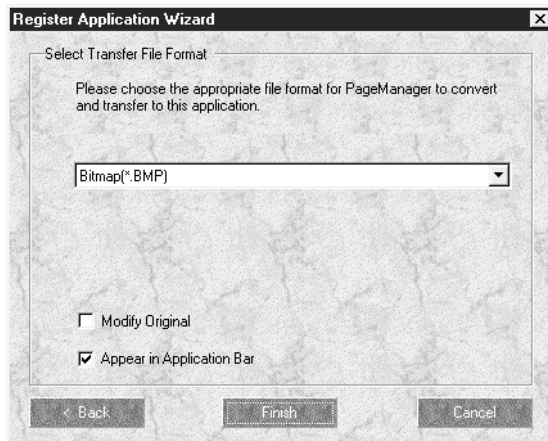

3. Specify the format of the image and click Finish.

Setting Up EPSON Scanner Monitor

EPSON Scanner Monitor is software that recognizes when the  Start button is pressed and sends information to assigned application software supporting the Start Button feature and EPSON Scanner Monitor, such as PageManager for EPSON.

Once EPSON TWAIN is installed on an operating system other than Windows 98, EPSON Scanner Monitor is active and identifies PageManager for EPSON as the application that allows you to use the Start Button feature. If you need to turn off Scanner Monitor, or select another application that supports the Start Button feature, access Scanner Monitor as described below.

Note:

- ❑ *Application software other than PageManager for EPSON which supports both EPSON Scanner Monitor and the Start button feature may be limited.*
- ❑ *Windows 98 supports the Start Button feature; therefore, EPSON Scanner Monitor is not installed automatically when you install EPSON TWAIN on Windows 98.*

For Windows 95 or NT 4.0 users

Click the Scanner Monitor icon located in the task bar on your desktop.

Scanner Monitor
icon

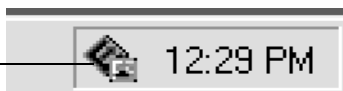

❑ Turning off Scanner Monitor

If you want to turn off Scanner Monitor, select **Close**. However, this will disable the scanner's Start Button feature.

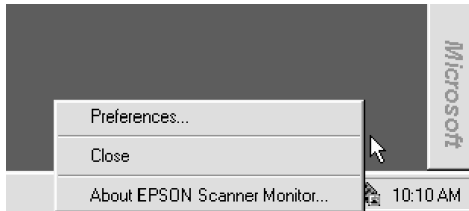

Note:

After you turn off Scanner Monitor, it will turn back on automatically the next time you start Windows.

To activate Scanner Monitor again, select Programs from the Start menu and click EPSON Scanner; then select EPSON Scanner Monitor. The Scanner Monitor icon appears in your taskbar.

❑ Assigning an application to Scanner Monitor

Select Preferences. The EPSON Scanner Monitor dialog box appears. You can select an application that supports the Start Button feature and EPSON Scanner Monitor, such as PageManager for EPSON.

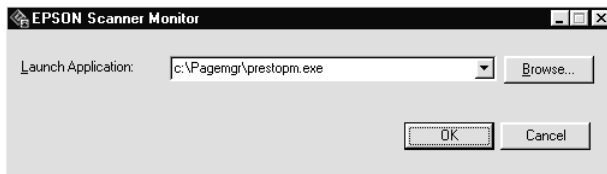

For Macintosh users

Select Epson Scanner Monitor Setup from the Apple menu.



Turning off Scanner Monitor

If you want to turn off Scanner Monitor, clear the Enable Monitoring check box. However, this will disable the scanner's Start Button feature.

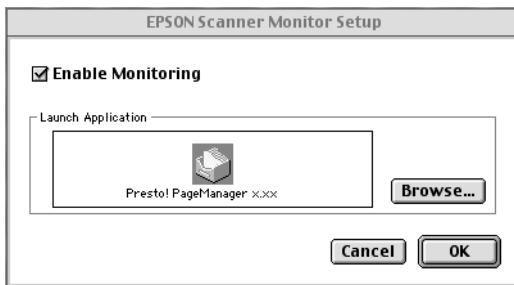

To activate Scanner Monitor again, select the Enable Monitoring check box.

❑ Assigning an application to Scanner Monitor

Click **Browse**. Select a folder and an application that supports the Start Button feature and EPSON Scanner Monitor, such as PageManager for EPSON.

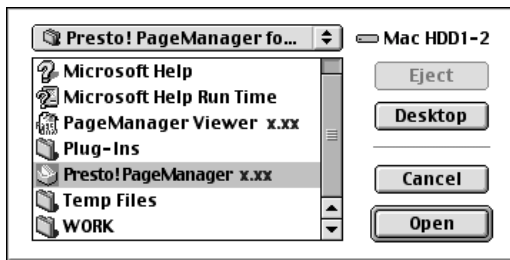

Setting Up the Start Button Feature for Windows 98

Without having EPSON Scanner Monitor installed, Windows 98 allows you to use the ⚡ Start button on your scanner without having to open an application that supports the Start Button feature. When you press the ⚡ Start button, you can have a scanned image automatically sent to your application, such as PageManager for EPSON, as long as it is installed.

Once EPSON TWAIN is installed on Windows 98, the Scanners and Cameras icon appears on the control panel, and your scanner is listed in the Scanners and Cameras Properties dialog box as shown below.

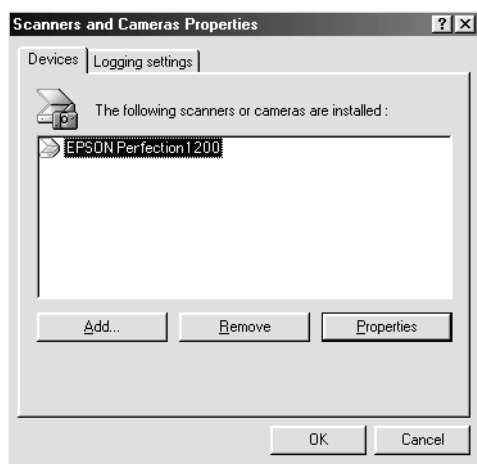

Assigning an application to the Start button

After you install applications that support “Scanner events”, such as PageManager for EPSON, you need to select one of those applications for the scanner event.

If you want to use your scanner’s ⚡ Start button with PageManager for EPSON as the supporting application, follow the steps on the next page.

1. Select your scanner from the installed scanners and cameras list in the Scanners and Cameras Properties dialog box. Click Properties, and then click the Events tab.

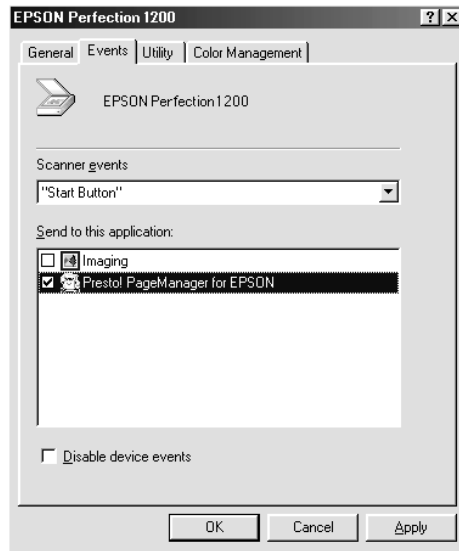

2. You can see the Start Button is listed as the scanner event. Make sure the check box of the application you want to assign to the Start button is selected and all other application check boxes are clear in the Send to this application list.

Note:

- If more than one application is selected, a dialog box appears prompting you to select an application when the Start button is pressed.
 - Some applications do not support linkage to scanners and digital cameras. Linkage is available only with the applications that appear in the Send to this application list.
3. Close the dialog box by clicking the OK button.

Disabling the Start button

If you need to disable the Start Button feature, select the Disable device event check box in the EPSON Perfection 1200 Properties dialog box. When this check box is clear, Windows 98 will detect if the  Start button is pressed and launch the application you selected in the Send to this application list.

Chapter 6

Options

Using the Film Adapter	6-2
Unpacking the Film Adapter	6-2
Installing the Film Adapter	6-3
Scanning transparent materials	6-4
Film holders.	6-4
Loading slides and film	6-6
Scanning normal (reflective) documents	6-12
Using the Automatic Document Feeder.	6-13
Unpacking the Automatic Document Feeder.	6-13
Installing the Automatic Document Feeder	6-14
Loading paper into your Automatic Document Feeder	6-16
Loading documents manually	6-17
Scanning from the Automatic Document Feeder	6-18
Fixing paper jams in the Automatic Document Feeder	6-20
Document specifications	6-22



Using the Film Adapter

The Film Adapter (B81317*) enables you to scan of negative film strips and slides simply by installing the unit on your scanner. The Film Adapter is compact so it can be attached or removed easily when you alternate scanning between transparent materials and normal reflective (paper) documents.

Unpacking the Film Adapter

When you first open the package, make sure that all the following items are included. If any items are missing or damaged, contact your EPSON dealer immediately. Do not throw away the package after unpacking the Film Adapter as it can be used again for storage when you are not scanning transparencies.

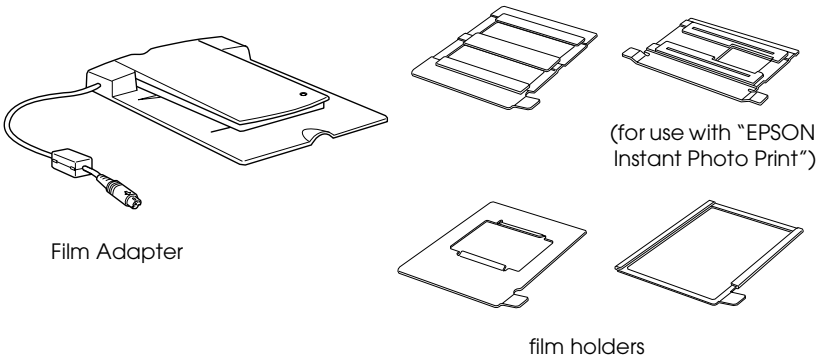

Installing the Film Adapter

Follow the steps below to install the Film Adapter on the scanner.

1. Make sure the scanner is turned off.
2. Remove the document cover from the scanner by opening it and pulling it straight up. (See page 4-6)
3. Place the Film Adapter on the document table so that the hinges face the rear of the scanner and it fits on the table.

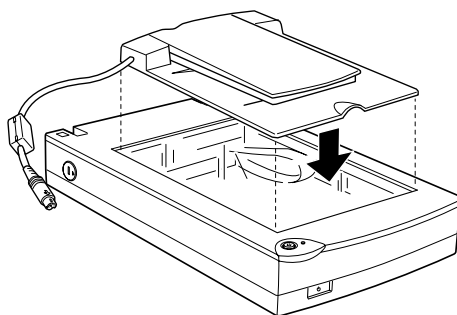

4. Connect the Film Adapter connector to the scanner's option connector.

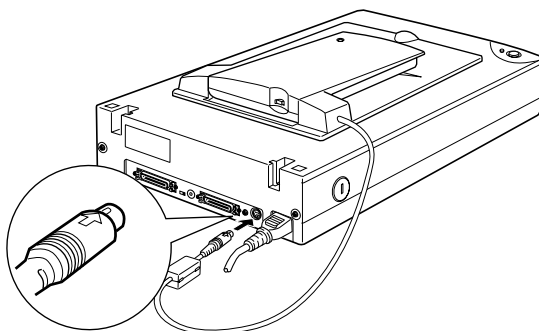

5. Turn on the scanner.
6. Turn on the Film Adapter.

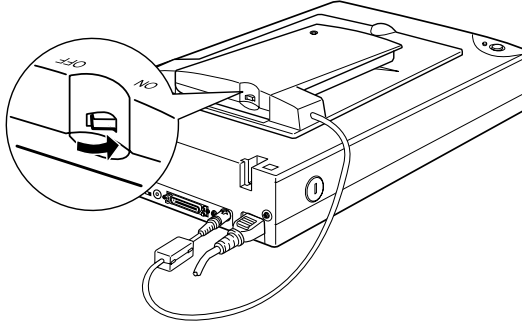

Scanning transparent materials

By attaching the Film Adapter, you can scan transparent materials, such as, positive and negative film, by passing light through the material. The following sections explain how to scan transparent materials.

Film holders

Four film holders are included with this unit. To scan film, see the instructions below.



Caution:

Hold the film at the edges, or else use gloves. Touching the film surface with bare hands can leave fingerprints or other traces on the film.

Note:

The base side of the film is the side which the film maker's name and film ID numbers are shown.

35 mm negative or positive film

Insert a strip of film in the 35 mm film holder, base side facing down.

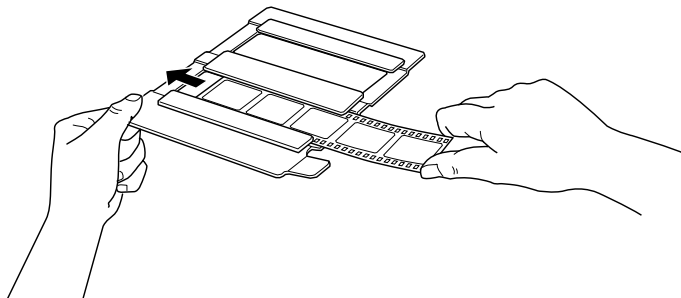

35 mm negative film (to be scanned from EPSON Instant Photo Print)

Insert a strip of film in the 35 mm film holder for use with EPSON Instant Photo Print, base side facing down. Slide the strip until all of the frame you wish to scan is positioned inside the film holder opening.

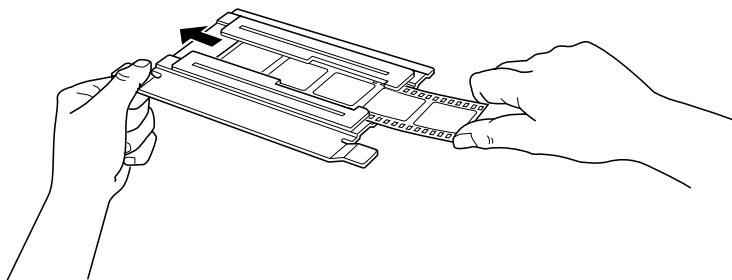

120/220 (6 cm x 9 cm) film

Insert film in the 120/220 (6 cm x 9 cm) size film holder, base side facing down.

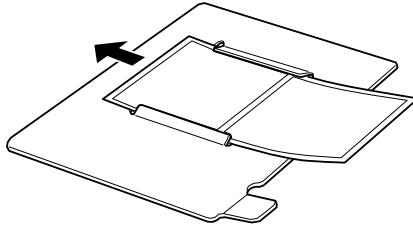

4 x 5 inch film

Insert film in the 4 x 5 inch film holder, base side facing down.

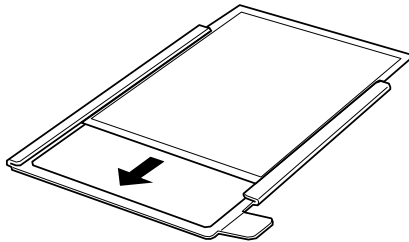

Loading slides and film

You can scan slides and film strip in the 4 x 5 inch (101.6 x 127 mm) scanning area of the Film Adapter.

Note:

- ❑ *Wipe the inside of the Film Adapter cover, the scanner's document table, and the narrow window near the hinges before scanning transparencies.*

- ❑ *You need to select TPU for Neg. Film or TPU for Pos. Film in the Document Source settings in EPSON TWAIN depending on the type of film (negative or positive) you are scanning. The scanner software automatically controls the operation of the Film Adapter.*

Follow the steps below to load film or slides.



Caution:

Hold the film at the edges, or else use gloves. Touching the film surface with bare hands can leave fingerprints or other traces on the film.

1. Open the top of the Film Adapter, holding the base down.

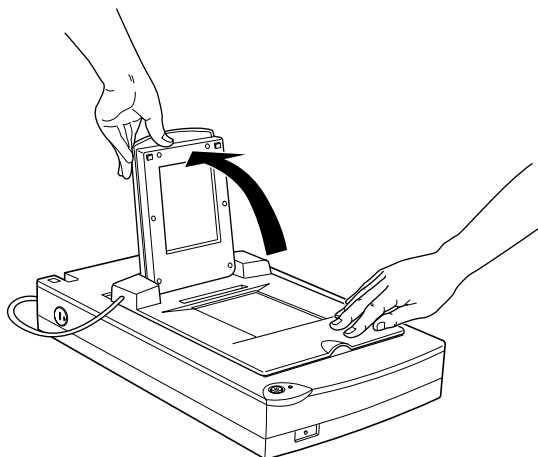

2. Load the transparency to be scanned face down on the scanner's document table in the window of the Film Adapter as shown below.

- ❑ If you are scanning 35 mm strip film, use the 35 mm film holder to set the film.

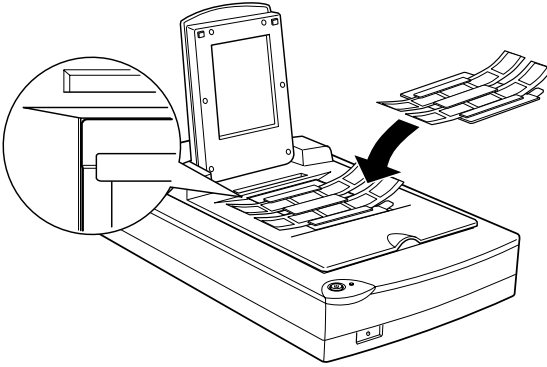

Note:

Place the film holder on the document table in alignment with the upper left-hand corner of the Film Adapter.

- ❑ If you are scanning 35 mm strip film using EPSON Instant Photo Print, use the 35 mm film holder for use with EPSON Instant Photo Print to set the film.

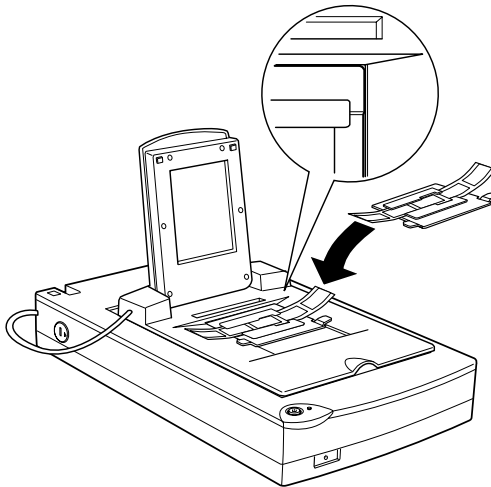

Note:

Place the film holder on the document table in alignment with the upper right-hand corner of the Film Adapter.

- ❑ When scanning 120/220 (6cm × 9cm) or similar film, use the film holder as shown below.

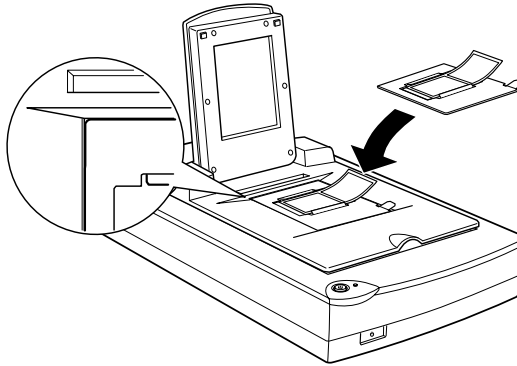

- ❑ If the film size is 4" × 5" or similar, use the film holder as shown below.

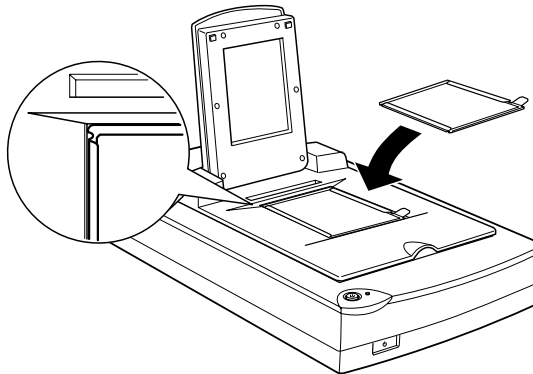

- ❑ If you are scanning slides or transparencies which will not fit in the film holders, place them directly on the document table.

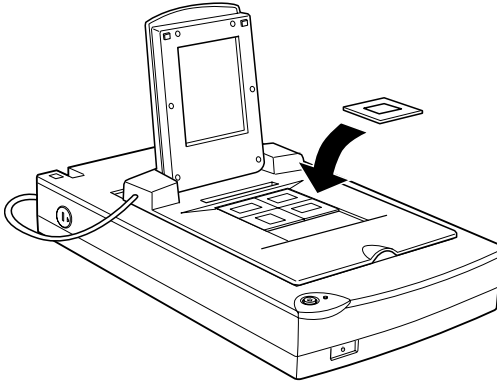

- ❑ If you are scanning slides or transparencies using EPSON Instant Photo Print, place them one at a time directly on the document table in alignment with the upper right-hand corner of the Film Adapter.

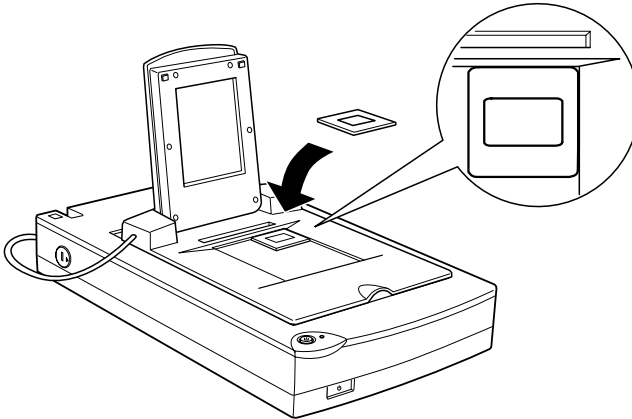

3. Close the unit.

Note:

- ❑ *Make sure the unit is completely closed, otherwise an option error results and you cannot scan the document, nor attain proper colored images.*
- ❑ *When previewing images on EPSON TWAIN of negatives scanned using a film holder, the color may appear odd as the frame of the film holder is perceived as white, causing your scans to appear darker. To see the correct color, click and drag the mouse over an area, then click the zoom preview button.*
- ❑ *You can move and adjust the position of 35mm film by sliding the strips in the film holder so the frames you want to scan are positioned in the window.*

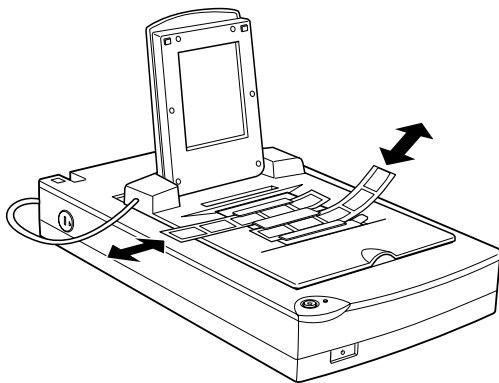

- ❑ *To remove a film holder from the document table, slide it left or right then take it out of the window.*

- ❑ *Leave the opening shown below uncovered, otherwise the colors in your scans will be affected.*

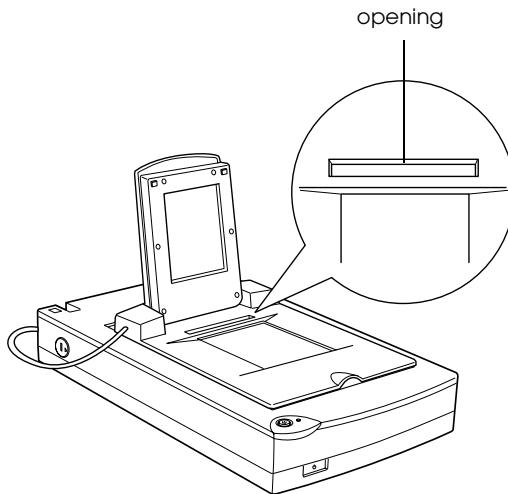

Scanning normal (reflective) documents

When you return to scanning normal reflective documents, you can simply turn off the Film Adapter, then place documents between it and the document table. If you will not scan transparencies for a long time, you can remove the Film Adapter and store it in the original package.

Remove the Film Adapter in reverse order as described on page 6-3.

Note:

- ❑ *When scanning thin documents, you may see an impression of the underside of the Film Adapter in your scans. If so, change to using the document cover instead of the Film Adapter.*
- ❑ *When you use EPSON Instant Photo Print to scan and print reflective documents, such as photos, first remove the Film Adapter and replace the document cover.*

Using the Automatic Document Feeder

The Automatic Document Feeder (B81314*) allows you to automatically load multiple-page documents into your scanner. This document feeder is particularly useful for OCR (optical character recognition) scanning, or for creating an image database.

Unpacking the Automatic Document Feeder

When you unpack your Automatic Document Feeder, make sure you have all the parts shown below. If any items are missing or damaged, contact your EPSON dealer immediately.

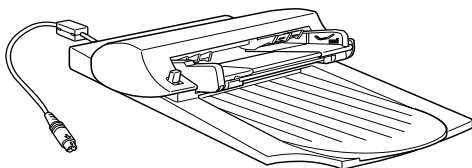

Automatic Document Feeder

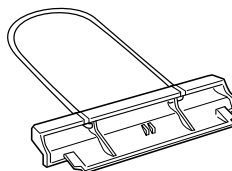

paper support

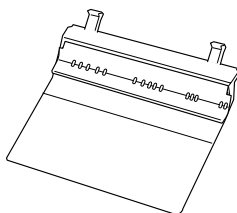

spare paper path guide

Installing the Automatic Document Feeder

Follow the steps below to install the Automatic Document Feeder on your EPSON scanner.

1. Make sure your scanner is turned off, and unplug the scanner's power cord.
2. Remove your scanner's document cover by opening it and pulling it straight up. (See page 4-6)
3. Remove the protective materials from the Automatic Document Feeder.
4. Insert the hinges on the Automatic Document Feeder into the holes at the back of the scanner and close the Automatic Document Feeder.

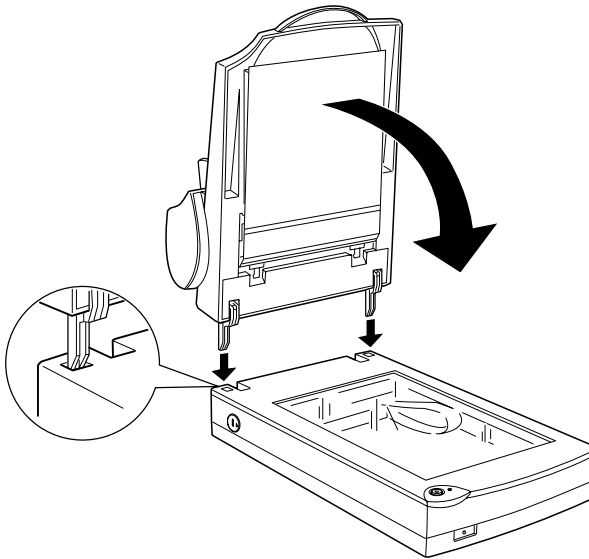

5. Attach the Automatic Document Feeder's connector to the scanner's option connector.

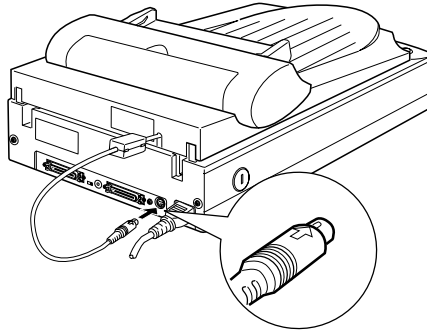

6. Attach the paper support to the Automatic Document Feeder.

6

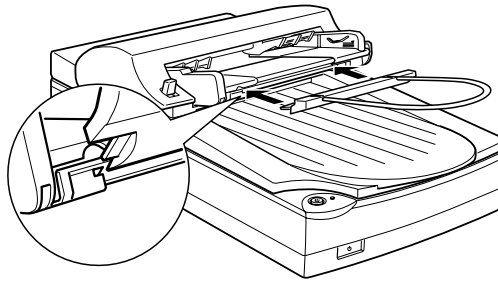

Note:

After you install the Automatic Document Feeder, be sure to select Automatic Document Feeder in the Document Source settings in EPSON TWAIN.

Loading paper into your Automatic Document Feeder

Your Automatic Document Feeder can automatically load up to 20 sheets of the following paper sizes (based on a paper weight of 17 lbs and a stack thickness of 4.0 mm or less):

Checks	85 × 127 mm (3.3 × 5 inches)
B5	182 × 257 mm (7.17 × 10.1 inches)
A4	210 × 297 mm (8.27 × 11.69 inches)
Letter	215.9 × 279.4 mm (8.5 × 11 inches)
Legal	215.9 × 355.6 mm (8.5 × 14 inches)

Follow the steps below to load paper into the Automatic Document Feeder.

Note:

Make sure no documents or dust is on the document table when using the Automatic Document Feeder. Dust on the document table near the carriage home position may result in vertical lines on the scanned images.

1. Slide the right edge guide all the way to the right.

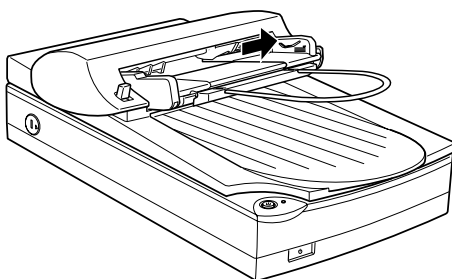

2. Insert the paper stack into the Automatic Document Feeder until it meets resistance. Make sure that the side you want to scan is facing up. Then move the right edge guide so it is flush with the right edge of your paper.

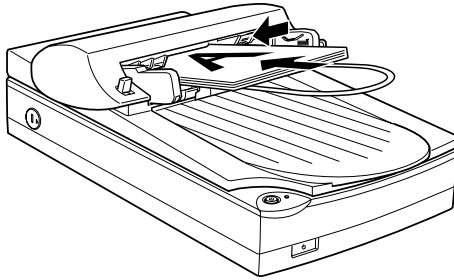

Documents are output into the lower tray after scanning is finished.

Note:

In the following situations, see the respective pages for problem-solving information:

- When paper is jammed, see page 6-20.
- When a scanned image has unwanted lines, see page 7-16.

Loading documents manually

You can load documents manually even when the Automatic Document Feeder is installed.

Lift the Automatic Document Feeder and place the document on the document table. Then lower the Automatic Document Feeder and scan the document.

Note:

- ❑ *Opening the Automatic Document Feeder or its cover while it is operating results in an option error and paper feeding stops.*
- ❑ *Always close the Automatic Document Feeder and its cover before scanning. If you are scanning thick material or documents of more than 2 cm in height, the Automatic Document Feeder can be left in the upright position.*
- ❑ *Be sure to select Flatbed in the Document Source settings in EPSON TWAIN.*
- ❑ *When scanning thin documents, you may see an impression of the underside of the Automatic Document Feeder in your scans. If so, change to using the document cover instead of the Automatic Document Feeder.*

Scanning from the Automatic Document Feeder

The scanning instructions are divided into two sections; read “Scanning the full document area” to scan an entire document or image, or read “Scanning only part of the document area” to scan only a certain part of an image or document.

Scanning the full document area

You do not need to use the preview feature when scanning a full document or image. The scanner automatically find and scans the whole image. Follow the steps below to scan an image or document.

1. Load paper in the Automatic Document Feeder as described on page 6-16.
2. Start the PageManager software.

3. Select EPSON TWAIN 4 for Windows or Macintosh SCSI users or EPSON TWAIN 4U for Macintosh USB users from Select Source of PageManager's File menu depending on your scanner configuration.
4. Select Acquire from File.
5. In the dialog box of EPSON TWAIN, make sure that Auto Document Feeder is selected from the Document Source list. Also choose appropriate settings for the scanning.
6. Click Scan.

After scanning the entire stack of documents, a window with thumb-nail images will appear. In this window you can select and change the orientation of the scanned images.

Scanning only part of the document area

To scan just a part of an image, follow the steps below.

1. Load the first page of the document in the Automatic Document Feeder as described on page 6-16.

Note:

Only set one page of the document at this time. If you set multiple pages at this time, the second page will be fed right after the first page is scanned and may become stuck in the middle of the document path as if the paper is jammed. In this case, you have to remove the second page from the document path and load it again.

2. Start PageManager software and select Acquire from the File menu.
3. In the dialog box of EPSON TWAIN, click Preview. The document is ejected after previewing.
4. Draw a marquee (frame around a certain area) to define the part of the image you want to scan by dragging the mouse pointer over that area.

5. Set document(s) to be scanned in the Automatic Document Feeder, including the ejected document.
6. Choose your settings in EPSON TWAIN and click the Scan button. Refer to HTML Scanner Software Reference Guide for details on choosing EPSON TWAIN settings.

After scanning the entire stack of documents, a window with thumb-nail images appears. In this window you can select and change the orientation of the scanned images.

Fixing paper jams in the Automatic Document Feeder

To clear jammed paper in the optional Automatic Document Feeder, follow the steps below:

1. Turn off the scanner.
2. Push down the release lever to slightly raise the feeder mechanism and release the paper.

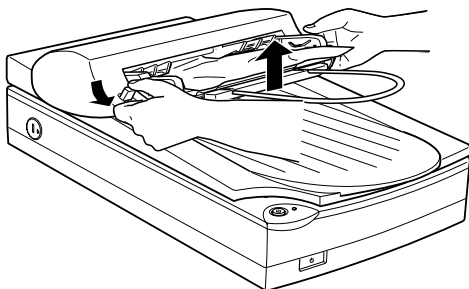

3. Then slowly pull the jammed paper out of the feeder mechanism. (Be careful not to pull too hard; the paper may tear, making it more difficult to remove.)

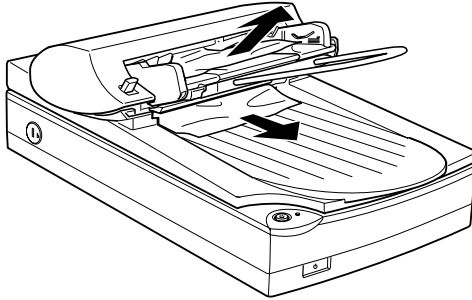

4. If paper is still jammed inside the mechanism, open the cover to remove it.

6

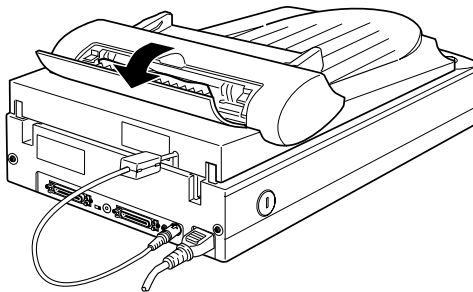

5. After removing jammed paper, make sure that the cover is closed, and the feeder mechanism is clicked down into place.

Document specifications

Size:	Width 3.3 to 8.5 inches (85 to 216 mm) Length 5 to 14 inches (127 to 356 mm)
Thickness:	0.07 to 0.16 mm
Weight:	58 to 122 g/m ²
Paper quality:	High-quality bond paper
Document type:	Documents printed with impact printers, laser printers, or facsimile machines

Document conditions

Check the following before feeding a document:

- Ink on the document is dry.
- The document has no holes, is not ripped or wrinkled, and has no articles attached to it.
- The document has no staples or other objects attached that might damage the feeder mechanism.
- The document has no folds closer than 5 mm from its edge.
- The document is not a multipart form or bound.
- The document has no rear carbon coating.
- The document has no cut out areas.

Other precautions

Do not feed photographic sheets or valuable original artwork into the Automatic Document Feeder as misfeeding a document may result in accidental wrinkling or damage.

When you are scanning high-quality color or halftone documents, it is recommended you open the Automatic Document Feeder and scan documents individually.

Chapter 7

Maintenance and Troubleshooting

Maintenance	7-2
Cleaning the scanner	7-2
Replacing the fluorescent lamp	7-3
Cleaning or replacing the paper path guide.	7-3
Transporting the Scanner	7-7
Problems and Solutions	7-8
Error indicator	7-9
Operating problems	7-10
Quality problems	7-13
Software setup problems	7-20
Software operation problems	7-22
Scanning problems	7-24
Paper jams	7-26
Changing the SCSI ID number or SCSI board.	7-27
Sizing Up Your System	7-28
RAM and hard disk size	7-28
Accelerator boards	7-29
Video cards	7-29
Monitors	7-29
File compression software.	7-29

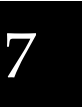

Maintenance

Cleaning the scanner

To keep your scanner operating at its best, you should clean it periodically, as described below.

1. Unplug the power cord.
2. Clean the outer case with mild detergent and water.
3. If the glass of the document table gets dirty, clean it with a soft dry cloth. If the glass is stained with grease or some other hard-to-remove material, use a small amount of glass cleaner and a soft cloth to remove it. Wipe off all remaining liquid.

Be sure that there is no dust on the glass of the document table. Dust can cause spots in your scanned image.



Caution:

- Be careful not to scratch or damage the glass of the document table, and do not use a hard or abrasive brush to clean it. A damaged glass surface can decrease the scanning quality.*
- Never use alcohol, thinner, or corrosive solvent to clean the scanner. These chemicals can damage the scanner components as well as the case.*
- Be careful not to spill liquid into the scanner mechanism or electronic components. This could permanently damage the mechanism and circuitry.*
- Do not spray lubricants inside the scanner.*
- Never open the scanner case.*

Replacing the fluorescent lamp

The luminosity of the fluorescent lamp declines over time. If the lamp breaks or becomes too dim to operate normally, the scanner stops working and the operate light rapidly flashes red. When this happens, the lamp assembly must be replaced. For details, contact your dealer.



Caution:

Never open the case of the scanner. If you think repairs or adjustments are necessary, consult your dealer.

Cleaning or replacing the paper path guide

If you notice the quality of your scans have declined, or you simply want to keep the quality of your scans at their best, clean the Automatic Document Feeder paper path guide.

If the paper path guide gets badly scratched and cleaning the guide does not improve the quality of your scans, replace it with the spare one.

Follow the instructions below to remove, clean, and reattach the paper path guide.

Removing the paper path guide

1. Turn off the scanner.
2. Disconnect the cable for the Automatic Document Feeder, and take the Automatic Document Feeder off the scanner.

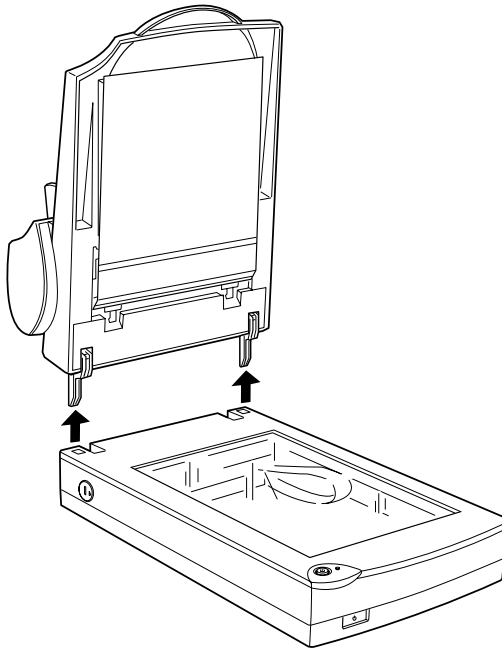

3. Take off the paper support.

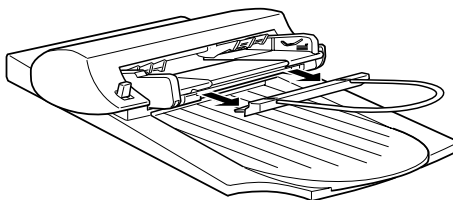

4. Put the Automatic Document Feeder on the table upside down.
5. Unclip the two white hooks to release the paper path guide. Pull the hooks out of the through holes.

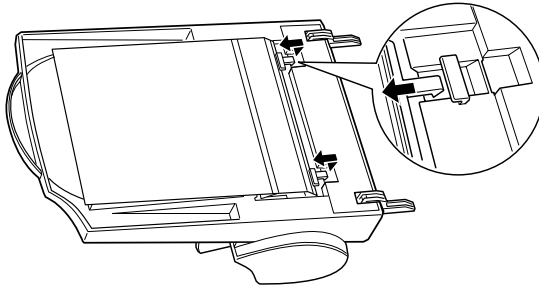

6. Remove the paper path guide.

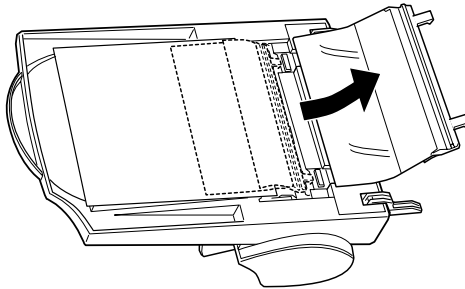

Cleaning the paper path guide

Gently wipe off dust from the transparent plastic sheet of the paper path guide with a soft dry cloth.

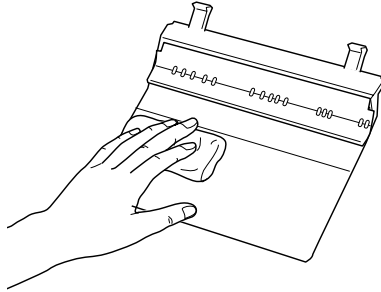

Caution:

- Be careful not to scratch or damage the paper path guide.*
- Be careful not to touch the rollers or metal parts of the Automatic Document Feeder, as damage may occur.*

Attaching the paper path guide

1. Insert the transparent plastic sheet of the paper path guide into the paper path of the Automatic Document Feeder.

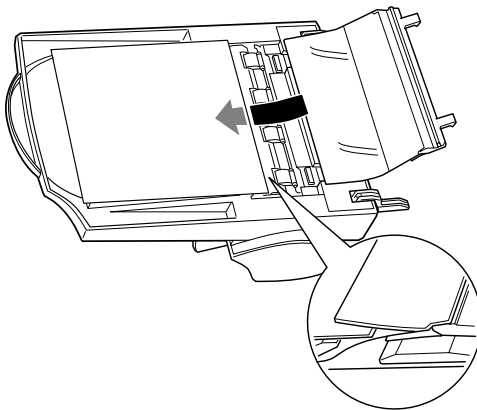

2. Insert the hooks into the rectangular through holes until they clip into place.

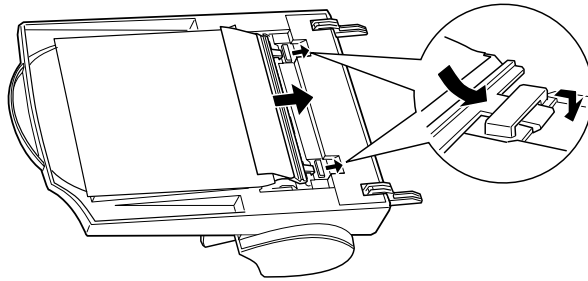

Transporting the Scanner

If you are transporting the scanner a significant distance or storing it for an extended period, follow the steps below to secure the carriage.

1. Turn on the scanner and wait until the carriage moves to the home position (position nearest the cover hinges). When the operate light turns green, turn off the scanner.
2. Turn the transportation lock to the locked position to secure the carriage.

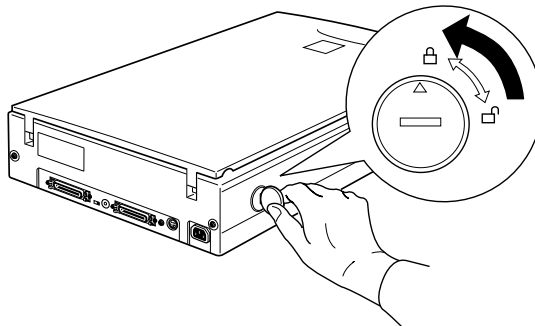

Note:

If you are using the Film Adapter and it is switched on, the carriage will not move to the home position. Remove the Film Adapter first, then perform the steps above.

Problems and Solutions

This section divides scanner problems into seven categories:

Error indicator	page 7-9
Operating problems	page 7-10
Quality problems	page 7-13
Software setup problems	page 7-20
Software operation problems	page 7-22
Scaning problems	page 7-24
Paper jams	page 7-26

See the table in “Error indicator” first. If this does not help you solve your problem, go to the category for the type of problem you have, then look for the problem description.

The online Color Guide also provides versatile tips and other information helpful for problem-solving.

Note:

If some settings appear dimmed in EPSON TWAIN, they cannot be selected because of the capability of your scanner or your choice of other settings.

If you cannot solve a problem after reading and following the information in this chapter, contact your dealer or a qualified customer support person for assistance.

Error indicator

If an error occurs, the scanner stops operating and the operate light shows the type of error.

Pattern of light	Problem and solution	
<p style="text-align: center;">●</p> <p>(Rapidly flashing red)</p>	<p>Cause 1:</p> <p>What to do 1:</p>	<p>The interface setup is wrong, or the scanner is not properly connected to the computer.</p> <p>Check the interface connection. Then turn the scanner off and back on to initialize the scanner again.</p>
	<p>Cause 2:</p> <p>What to do 2:</p>	<p>The transportation lock is not released, the fluorescent lamp needs to be replaced, or the scanner is broken.</p> <p>Make sure that the transportation lock is in the unlocked position; then turn the scanner off and then back on. If the scanner still does not operate properly, or if this error occurs repeatedly, consult your dealer.</p>
<p style="text-align: center;">●</p> <p>(Rapidly flashing orange)</p>	<p>Cause 1:</p> <p>What to do 1:</p>	<p>The cover of the optional Automatic Document Feeder is open, or the release lever is pressed and paper feeding unit is slightly open.</p> <p>Make sure that the cover of optional Automatic Document Feeder is closed and/or push the paper feeding unit down until it clicks into place.</p>
	<p>Cause 2:</p> <p>What to do 2:</p>	<p>No paper is loaded, or paper is jammed in the Automatic Document Feeder.</p> <p>Load paper in the Automatic Document Feeder, or turn the scanner off and remove the jammed paper from the Automatic Document Feeder. See page 6-16 or 6-20 for details.</p>

○ = on, ● = off, ● = flashing

Operating problems

Problems you may have while using the scanner often involve the operation of your software and computer. Operation problems usually occur because of:

- ❑ Incorrect setup of the interface (see Chapter 2).
- ❑ Inappropriate selection of the scanner functions (see your software documentation).
- ❑ Incorrect setup of your computer or software (see Chapter 2 in this guide or the software documentation).
- ❑ Incorrect operation of your software (see your software documentation).

Also see the documentation that came with your computer and printer for possible solutions.

The Operate light does not come on.

Cause	What to do
The scanner is off.	Press the  operate button to turn on the scanner.
The scanner is not connected correctly.	Make sure the power cord is connected to the scanner and plugged into a power outlet.

The scanner does not scan.

Cause	What to do
The scanner is not ready to scan.	Wait until the operate light is green (ready for scanning).

Interface port or software settings are incorrect.

Make sure your interface port and software settings are correct. Also make sure that your computer's interface board is installed properly.

For SCSI model users :
SCSI ID or terminator is incorrect .

Make sure the scanner's SCSI ID and terminator are set correctly. See "Connecting the Scanner (SCSI) to Your Computer" on page 2-8.

Interrupt settings are conflicting with your SCSI board.

If you have other expansion boards in your computer, make sure that their interrupt settings are interfering with your SCSI board. See your computer's documentation for details.

For USB model users :
More than one hub is in use, or the cable is unsuitable.

Try connecting the scanner directly to the computer's USB port, or use an EPSON USB cable .

The scanner software does not work properly.

Cause

What to do

Software is not installed properly.

Make sure your software is installed correctly.

For Windows 98 users:

Check if your scanner is listed more than once in the Scanners and Cameras Properties dialog box. To view the dialog box, double-click the Scanners and Cameras icon in Control Panel. Remove your scanner every place it appears in the dialog box, then reinstall EPSON TWAIN following the instructions in the Chapter 3.

Note:

When reinstalling the scanner software, if a dialog box does not appear and a message box and followed by a dialog box requesting the EPSON Scanners Driver Disk appears instead, insert the Scanner Software CD in the CD-ROM drive. Make sure to specify the correct drive letter, the EPSON folder, the folder of your preferred language, and the Win98 folder as the location.

Computer system doesn't meet the requirements.

Make sure your computer meets the memory and other system requirements specified for the software you are using.

Not enough memory is available.

Make sure the computer has enough memory for your software. If the computer does not have enough memory available, see your software and computer documentation for details.

Quality problems

The entire image is distorted or blurred.

Cause	What to do
Document is not placed correctly.	Make sure the document is flat against the document table.
Document was moved.	Make sure you do not accidentally move the document during scanning.
Scanner orientation is unsuitable.	Make sure the scanner is on a flat, stable surface.

Part of the image is distorted or blurred.

Cause	What to do
The document condition is poor or the document was placed incorrectly.	Make sure the document is uniformly flat against the document table. A document that is wrinkled or warped may not scan well.



Caution:

Do not place heavy objects on the document table.

Edges of the document are not scanned.

Cause	What to do
The document size exceeds the readable scanning area.	Position the document so the area you want to scan is within the edge guide limits of the document table. Note that an area 3mm in from both horizontal and vertical guides will not be scanned.

Colors are patchy or distorted at the edges of the image.

Cause	What to do
-------	------------

The document is too thick or warped, or there is too much outside light.	A document that is very thick or warped at the edges can cause discoloration. Cover the edges of the document with paper to block outside light.
--	--

The document is not placed correctly.	Make sure the document is flat against the document table.
---------------------------------------	--

The image is faint or out of focus.

Cause	What to do
-------	------------

The document is not placed correctly.	Make sure the document is flat against the document table.
---------------------------------------	--

Exposure setting is unsuitable.	Adjust your software's Exposure setting. See the online Reference Guide.
---------------------------------	--

Gamma setting is unsuitable.	Adjust your software's Gamma setting. See the online Reference Guide.
------------------------------	---

The image is too dark.

Cause	What to do
-------	------------

Brightness is unsuitable.	Check your software's Brightness setting. Check the brightness and contrast settings of your computer display. See the online Reference Guide.
---------------------------	--

Straight lines in the image come out jagged.

Cause	What to do
Document is not placed correctly.	Make sure the document orientation is perfectly straight on the document table. Align vertical and horizontal lines with the scales at the top and side of the document table.

The image does not look the same as the original.

Cause	What to do
Image settings are incorrect.	Try different image setting combinations on your scanner software.
Color matching software is not sufficient, or not installed properly.	Your software may not have sufficient color matching and color management features, or these components may not be installed correctly. See the documentation that comes with your software and computer.
File format or image settings are unsuitable.	If you are importing an image file, make sure the file format is one your software can read. Also, make sure the image settings of your software are appropriate for the type of image you want to scan.

A line of dots is always missing from the scanned image.

Cause**What to do**

The print head has malfunctioned.

Print head malfunction is indicated when a line is missing on printouts only. See your printer manual.

The scanner sensor has malfunctioned.

Scanner sensor malfunction is indicated when a line is missing on both screen images and printouts. Contact your dealer.

A line of dots always appears in the scanned image.

Paper path guide or document table is dusty or scratched.

If this happens on both your screen and printout, the paper path guide of the Auto Document Feeder or the document table may be dusty or scratched. Clean the paper path guide or clean the document table. If the problem still exists the guide may be scratched and require replacement.

Moiré (cross hatch) patterns appear in the scanned image during halftone scanning

Cause**What to do**

Image Type setting is unsuitable.

Select the Color Photo De-screening setting in the Image Type list or select On for De-screening in the Image Type dialog box.

Transparent sheet was not used.

Place a transparent sheet between the document and document table to defocus the image.

Document is not positioned correctly.	Move or angle the document slightly.
Unsharp Mask is selected.	Clear the check from the Unsharp Mask check box in EPSON TWAIN.
Image size setting is unsuitable.	Change the image size smaller slightly.

Colors differs from the original or look strange.

Cause	What to do
Screen is not calibrated.	Calibrate the screen. See Chapter 3.
Image Type and Destination settings are incorrect.	Make sure the Image Type (page 4-12) and Destination settings (page 4-13) are correct.
Opening on the document table is covered, or Film Adapter was not closed during scanning.	When using the Film Adapter, make sure the opening near the hinges on the document table is uncovered, or the Film Adapter is closed when scanning.
Normal scanning.	Printed colors will not exactly match the colors on your monitor, since printers and monitors use different color systems: monitors use RGB (red, green, and blue), while printers typically use CMYK (cyan, magenta, yellow, and black).

Colors on your monitor are different from those in the original image.

Cause

What to do

Software image settings need adjustment.

Check the image settings of your scanner software, especially data format (bits, pixel, color), gamma correction, and color correction. Try different combinations of these settings.

Color matching and color management capabilities of your system are insufficient.

Check the color matching and color management capabilities of your computer, display adapter, and software. Some computers can change the color palette to adjust the colors on your screen. See your software and hardware manuals for details.

Normal scanning.

Exact color matching is very difficult. Check your software and monitor documentation for information on color matching and calibration. Also see your *Color Guide*.

Printed colors are different from those in the original image.

Cause

What to do

Normal scanning.

Exact color matching is very difficult. Check your software or contact your printer company for information on color matching and calibration.

The printed image is larger or smaller than the original.

Cause	What to do
Printed size was judged using the monitor image.	The image size settings of your software determine the size of the printed image. Do not use the size of the monitor image to judge the printed size.

Scanned images cannot be printed or come out garbled when printed.

Cause	What to do
Printer is not connected or set up properly, or maintenance is necessary.	Make sure your printer is properly connected to the computer, correctly set up, and maintained. See your printer manual for details.
Software is not installed properly.	Check that your software is properly installed and set up for your printer. See Chapters 3 and 4.

The colors of negative film preview images look strange.

Cause	What to do
Document Source setting is incorrect.	Make sure the EPSON TWAIN Document Source setting is TPU for Neg. Film.

Using the film holder frame.

The dark area around the film, such as the frame of the film holder, is perceived as white, which alters the exposure of the scanning area and causes scans to appear darker. See the correct color by clicking and dragging the mouse over an area, and then clicking the zoom preview button.

Software setup problems

You cannot install EPSON TWAIN.

Cause	What to do
System configuration does not meet the requirements.	Check your computer and operating system meets the system requirements on pages 3-2 to 4. Make sure your computer has enough memory to run the application.

The scanner does not appear in the Port list of the EPSON TWAIN 4 dialog box in the Control Panel when you connect the SCSI model to your PC running Windows other than Windows 98.

Cause	What to do
SCSI connection is not made properly.	Turn off the computer and scanner and check the connection between your hardware.
SCSI ID number is unsuitable.	Change the SCSI ID number to one that is not being used by any other SCSI device.

Connection sequence is incorrect.

Check the connection sequence and make sure the scanner's terminator switch is set correctly. See Chapter 2 for details.

The Scanner Status does not indicate "Device Ready" after you click Test in the EPSON TWAIN 4 dialog box or the Scanner's Properties dialog box (Windows 98) in the Control Panel.

Cause

What to do

Interface cable is unsuitable.

Make sure the interface cable meets the requirements of your interface board. See the manual that comes with the interface board.

Connection is not made properly.

Turn off the scanner and computer and check the connection between the scanner and computer.

SCSI interface board is not installed properly.

Make sure the SCSI interface board is installed correctly.

Power on sequence is incorrect.

Turn off the scanner and computer. Turn on the scanner and then turn on the computer.

SCSI driver is not installed correctly.

Make sure the SCSI driver is properly installed.

SCSI ID number is unsuitable.

Change the scanner's SCSI ID number to one that is not being used by any other SCSI device.

Connection sequence is incorrect.

Check the connection sequence and make sure the scanner's terminator switch is set correctly. See Chapter 2 for details.

Film Adapter is not switched off.	If the Film Adapter is installed, make sure it is switched off.
-----------------------------------	---

Software operation problems

You cannot start EPSON TWAIN.

Cause	What to do
Scanner is switched off.	Turn on the scanner and then turn on the computer.
Interface cable is unsuitable.	Make sure the interface cable meets the requirements of your interface board. See the manual that comes with the interface board.
Connection is not made properly.	Turn off the scanner and computer and check the connection between the scanner and the computer.
Interface board is not installed properly.	Make sure the interface board is installed correctly.
Incorrect selection of TWAIN Data Source in application.	Make sure that EPSON TWAIN 4 or 4U is selected properly in your application software. See "Starting EPSON TWAIN through your application software" on page 4-8.

Software is not installed properly and EPSON TWAIN 4 or 4U does not appear in the TWAIN Data Source list.

Make sure your software is installed correctly.

For Windows 98 users:

Check if your scanner name appears under Imaging Device hardware type without a ? or ! mark in the Device Manager menu. To view this menu, right-click the My Computer icon on the Desktop. If your scanner appears with a ? or ! mark, or appears as an Unknown devices hardware type, click Remove while your scanner is connected and turned on to remove it from the Device Manager menu. Then reinstall EPSON TWAIN following the instructions in the Chapter 3.

Note:

If the EPSON Scanners Driver Disk is requested when reinstalling the scanner software, insert the Scanner Software CD in the CD-ROM drive and make sure to specify the correct drive letter, the EPSON folder, the folder of your preferred language, and the Win98 folder as the location.

You can't select optional equipment (Automatic Document Feeder or Film Adapter).

Cause	What to do
Option is not installed properly.	Make sure the optional equipment is installed correctly. See Chapter 6.

Scanning problems

Image is dark, with little or no detail.

Cause	What to do
Screen is not calibrated.	Calibrate the screen as described in “Calibrating Your Screen” on page 3-25.
Destination setting is incorrect.	Select Screen/Web as the Destination setting (page 4-13). Selecting a printer may cause onscreen colors to be different from the colors of the original, however colors will be reproduced correctly when it is printed.

You cannot scan an image or you only get a few dots for the scanned image.

Cause	What to do
No document on the document table.	Make sure you have placed a document on the document table of the scanner.
Threshold setting needs changing.	When OCR is selected as the Image Type, change Text Enhancement Technology to None from the B/W Option in the Image Type dialog box. Then change the Threshold setting in the Image Controls dialog box. See “Image Controls” on the online Software Reference Guide.

When OCR is selected as the Image Type, change OCR to Line Art, then change the Threshold setting in the Image Control dialog box. See “Image Controls” on the online Software Reference Guide.

Scanned image is too large.

Cause	What to do
Destination setting is unsuitable.	Select Screen/Web as the Destination setting (page 4-13). Selecting a printer as the Destination setting (page 4-13), the print size will appear in the correct size even if the image is enlarged on the screen in some application .

Poor character recognition during OCR scanning.

Cause	What to do
Image Type setting is unsuitable.	Select OCR as the Image Type setting.
Threshold setting is unsuitable.	Try adjusting the Threshold setting in the Image Controls dialog box.
Background noise on the document.	Select Text Enhancement Technology from the B/W Option in the Image Type dialog box.

Scanning does not start by pressing the Start button.

Cause	What to do
Scanner Monitor software is not installed properly. (For Windows 95, NT 4.0 and Macintosh)	Make sure the Scanner Monitor software is running and check the Scanner Monitor's Launch Application path is set correctly.
Scanner Event is not selected properly. (For Windows 98)	Click the Events tab in your scanner's Properties dialog box and make sure the Disable device events check box is clear. And make sure the Start button is selected as the Scanner events, and at least one scanner event recognizable application in the Send to this application box is selected.

Paper jams

Paper gets jammed in the Automatic Document Feeder.

Cause	What to do
Paper cannot pass smoothly through the Automatic Document Feeder.	Remove the jammed paper. See page 6-20.

Changing the SCSI ID number or SCSI board

If you are using your scanner with Windows 98 and you want to change the scanner's SCSI ID number or replace the SCSI board with a new one, follow the steps below.

1. Double-click the Scanners and Cameras icon in the Control Panel.



2. Select your scanner in the installed devices list, then click Remove.

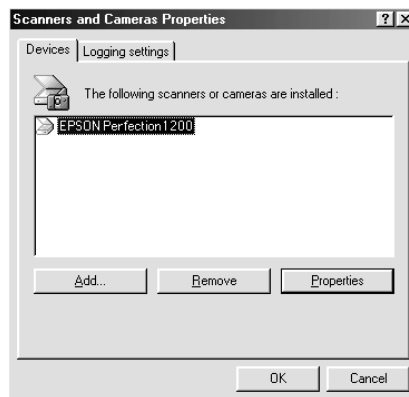

3. Click OK and close the dialog box.
4. Shut down Windows 98 and turn off your PC and scanner.
5. Change the SCSI ID number (see page 2-10), or replace the SCSI board (see page 2-4).
6. Turn on your scanner and then your PC.
7. Follow the instructions on the screen.

Note:

If the EPSON Scanners Driver Disk is requested, insert the Scanner Software CD in the CD-ROM drive and make sure to specify the correct drive letter, the EPSON folder, the folder of your preferred language, and the Win98 folder as the location.

Sizing Up Your System

Your scanner is sufficient for most scanning needs, but if you are not satisfied with the quality of the images on your monitor or with the speed of image processing, read this section. While it does not contain specific recommendations, it describes various possibilities for improving your scanning system. For further information, seek advice from your dealer or an experienced scanner user.

RAM and hard disk size

Scanned images use much more memory than text files, so you may need more RAM (Random Access Memory) in your computer and a larger hard disk than you have used previously.

Accelerator boards

In addition to memory, processing speed is important because large files take longer to process than small ones. Therefore, you may want to add an accelerator board to your computer.

Video cards

A video card that is sufficient for text may not be good enough for displaying graphic images, especially in color. If all your scanned images look coarse on your monitor, you may want to upgrade your video card. You will need 24-bit color, also called true color or millions of colors, to make the highest quality image reproductions.

Monitors

The resolution of your monitor affects the quality of the image you see. Consider a high resolution monitor if you do precise color work, but also be sure you have a high quality video card.

File compression software

Many different programs are available to make image files smaller for storage or transmission. For example, some compression software can store a 3MB image file on a 1.44MB floppy disk, and compress images and restore them with no loss of data or quality; others compress images more, but the restored file is not exactly the same as the original. The difference between the original and restored files is, however, almost unnoticeable.

Appendix A

Technical Specifications

Scanning	A-2
Electrical	A-4
Environmental	A-4
Safety Approvals	A-5
CE marking	A-5
SCSI Interface	A-6
USB Interface	A-7
Initialization Methods	A-8
Film Adapter	A-9
Automatic Document Feeder	A-10



Scanning

Scanner type:	Flatbed, color
Photoelectric device:	Color CCD line sensor
Effective pixels:	10200 × 14040 pixels at 1200 dpi, 100%
Document size:	216 mm × 297 mm (8.5 inches × 11.7 inches) A4 or US letter size (The reading area can be specified from your software.)
Scanning resolution:	1200 dpi (main scan) 2400 dpi with Micro Step (sub scan)
Output resolution:	50 dpi to 9600 dpi (50 to 4800 dpi in 1 dpi increments, 7200 dpi, and 9600 dpi. 7200 dpi and 9600 dpi performed with zoom function)
Color separation:	RGB color filters on CCD
Reading sequence:	
Monochrome	One-pass scanning
Color page sequence	Three-pass scanning (R, G, B) (This sequence is not supported by EPSON TWAIN)
Color byte sequence	One-pass scanning (R, G, B)
Color line sequence	One-pass scanning (R, G, B)
Zoom:	50% to 200% in 1% increments
Image data:	12 bits per pixel per color internal 8 bits per pixel per color external

Brightness:	7 levels (In EPSON TWAIN, Gamma correction controls Brightness)
Line Art settings:	Fixed threshold Text Enhancement Technology (enable/disable selectable)
Halftoning process:	AAS (Auto Area Segmentation) Enable/disable selectable 3 halftoning modes (A, B, and C) and 4 dither patterns (A, B, C, and D) for bi-level and quad-level data (2 downloadable dither patterns)
Gamma correction:	2 types for CRT display 3 types for printer 1 type for user-defined
Color correction:	1 type for CRT display 3 types for printer output (available in color byte sequence mode and color line sequence mode) 1 type for user-defined (Only user-defined Color correction is available in EPSON TWAIN)
Interface:	SCSI (50 pin half pitch connectors) or USB (Type B Receptacle Connector)
Light source:	White cold cathode fluorescent lamp
Reliability:	30,000 cycles of carriage movements (main unit MCBF)
Dimensions:	Width: 287 mm (11.3 inches) Depth: 427 mm (16.8 inches) Height: 90 mm (3.5 inches)
Weight:	Approx. 4.5 kg (9.9 lb)

Electrical

	100–120 V model	220–240 V model
Input voltage range	AC 90 to 132 V	AC 198 to 264 V
Rated frequency	50 to 60 Hz	
Rated current	0.5 A	0.3 A
Power consumption	Approx. 25W (operating) Approx. 10W (standby)	

Note:

Check the label on the back of the scanner for voltage information.

Environmental

Temperature:

Operation 5° C to 35° C (41° F to 95° F)
 10° C to 32° C (50° F to 89° F)
 when using the ADF

Storage –25° C to 60° C (–13° F to 140° F)

Humidity:

Operation 10% to 80%, without condensation

Storage 10% to 85%, without condensation

Operating conditions: Ordinary office or home conditions.
 Extreme dust should be avoided.
 Operation under direct sunlight or
 near a strong light source should be
 avoided.

Note:

Specifications are subject to change without notice.

Safety Approvals

120V model:

Safety standards UL 1950 with D3
CSA C22.2 No. 950

EMC FCC part 15 Subpart B Class B
CSA C108.8 Class B

230V model:

Safety standards EN 60950

EMC EN 55022 (CISPR Pub 22) Class B
AS/NZS 3548 Class B

CE marking

230 V model:

Low Voltage Directive 73/23/EEC EN 60950
EMC Directive 89/336/EEC EN 55022 Class B
EN 61000-3-2
EN 61000-3-3
EN 50082-1
IEC 801-2
IEC 801-3
IEC 801-4



A

SCSI Interface

- Interface type: ANSI X3T9.2/375R Revision 10L (SCSI 2)
- Functions: BUS FREE phase
ARBITRATION phase
SELECTION/RESELECTION phase
COMMAND phase
(Logical Unit Number is fixed to 0 and command link function is not supported.)
DATA phase
Data in phase
Data out phase
STATUS phase
MESSAGE phase
MESSAGE IN phase
MESSAGE OUT phase
ATTENTION condition
RESET condition
- Logic level: TTL compatible
- Electrical standard:ANSI X3T9.2/375R Revision 10L (SCSI 2)
- ID Setting: Selectable from 0 to 7
- Terminator: Internal terminator selectable (enable/disable)
- Connector type: Two half pitch 50-pin connectors
- Connector pin arrangement:

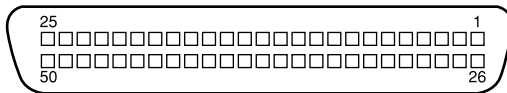

USB Interface

Interface type: Universal Serial Bus Specification Revision 1.0

Configuration:

Element	Description
Device	Full Speed mode (12Mbit/s) Class : Vendor-specific Vendor ID : 0x04B8 (Seiko Epson Corp.) Product ID : 0x0104
Configuration	Characteristics : Self-powered Remote wake up feature: Not supported Maximum power consumption from VBUS : 2mA (5V)
Interface	No alternate setting Number of endpoints used by this interface (excluding endpoint 0) : 2 Class : Vendor specific
Endpoint 1	Bulk IN transfer Maximum data transfer size : 64 byte
Endpoint 2	Bulk OUT transfer Maximum data transfer size: 64 byte
String Descriptor	Language ID : US English 1 : iManufacturer: "EPSON" 2 : iProduct: "Perfection1200"

Electrical standard: Full Speed mode(12Mbit/s) of Universal
Serial Bus Specification Revision 1.0.

Connector type: One receptacle (Type B)

A

Initialization Methods

The scanner can be initialized (returned to a fixed set of conditions) in the following ways:

SCSI model

Hardware initialization	<ul style="list-style-type: none">* The scanner is turned on.* The scanner receives a SCSI Reset signal from the SCSI interface.
Software initialization	<ul style="list-style-type: none">* Software sends the ESC @ (initialize the scanner) command.* The scanner receives a SCSI Bus Device Message.

USB model

Hardware initialization	<ul style="list-style-type: none">* The scanner is turned on.* The USB cable is unplugged from the USB port on the scanner.
Software initialization	<ul style="list-style-type: none">* Software sends the ESC @ (initialize the scanner) command.* The scanner receives a Bus Reset from the USB interface.

Film Adapter

Electrical Specifications:

Supplied Voltage: DC 21.6 to 26.4 V

Rated current: 0.5A

Environmental Conditions:

Temperature

Operation: 5° C to 35° C (41° F to 95° F)

Storage: -25° C to 60° C (-13° F to 140° F)

Humidity

Operation: 10% to 80%, without condensation

Storage: 10% to 85%, without condensation

Reliability:

Light Source: 10,000 hours for light source MCBF

Document:

Transparencies up to 4 x 5 inches film

35 mm strip film

35mm slide

120/220 size (6cm x 9cm) strip film

4 x 5 inches film

Manuscript: Up to 4 x 5 inches film size

Readable area: 93 x 118 mm

Dimensions: Width: 222 mm (8.7 inches)
Depth: 305 mm (12.0 inches)

Height: 36 mm (1.4 inches)

Weight: Approx. 700g (1.5 lb)

Automatic Document Feeder

General specifications:

Paper supply: Face up load
Paper out: Face down eject
Paper setting quantity: 20pcs (55g paper, maximum total thickness under 4 mm)

Electrical specifications:

Input voltage: DC 22.8 to 25.2 V
DC 4.75 to 5.25 V
Input Current: 24V: 0.8 A
5V: 0.2 A

Environmental conditions:

Temperature

Operation: 10° C to 32° C (50° F to 90° F)
Storage: -20° C to 60° C (-4° F to 140° F)

Humidity

Operation: 20% to 80%, without condensation
Storage: 10% to 85%, without condensation

Reliability: 20,000 sheets (Load/Eject MCBF)
10,000 sheets for Transparency Film
(Load/Eject MCBF)
12,000 cycle of movements (Hinge MCBF)

Dimensions: Width: 319 mm (12.6 inches)
Depth: 451 mm (17.8 inches)
Height: 137 mm (5.3 inches)

Weight: Approx. 2.2 kg (4.9 lb)

Appendix B

Contacting Customer Support

For United Kingdom and the Republic of Ireland Users B-3
For Australian Users B-5
For Singapore Users B-6
For Hong Kong Users B-7
For Philippines Users B-8



If your scanner is not operating properly and you cannot solve your problem using the troubleshooting information in this guide or online help, contact customer support services for assistance.

We will be able to help you more quickly if you are able to give the exact information indicated below.

Serial number of your scanner:

(The serial number label is on the back of the scanner.)

Brand and model of your computer:

Scanner software version:

(Click the ABOUT button on the Help menu in your application for the version number.)

Version of Windows (95, 98, NT 4.0, and so on):

Software application(s) you normally use with your scanner and their version number(s):

For United Kingdom and the Republic of Ireland Users

If you purchased your product in the UK or the Republic of Ireland, EPSON (UK) LTD provides a range of customer services and technical support.

Support Via the World Wide Web

- ❑ For information on the latest EPSON products, software drivers, on-line user guides and answers to frequently asked questions:

<http://www.epson.co.uk>

- ❑ To email EPSON Technical Support:

<http://www.epson.co.uk/support/email/>

- ❑ For a full list of EPSON Customer and Warranty Support services:

<http://www.epson.co.uk/support/>

Support Via Telephone

Our Customer and Warranty Support teams can be contacted by calling 0870 163 7766 in the UK or 0044 0870 163 7766 from the Republic of Ireland. They can provide the following services:

- ❑ Technical information on installing, configuring and operating your EPSON products
- ❑ Arranging for faulty EPSON products to be repaired within the warranty period

Before you call, please have the following information ready:

B

Product Model:

Serial number of your product:

(The serial number label is on the back of the product)

Brand and model of your computer:

Driver software version:

(Click the About button in your driver)

Operating System (for example, Windows 3.1/ 95/98, NT 3.5/ 4.0, Mac OS):

Software applications(s) you normally use with your product and their version numbers(s):

Pre Sales Enquiry Desk

Our Enquiry Desk team can be contacted by calling 0800 220546 in the UK or 1 800 409132 from the Republic of Ireland, by faxing 01442 227271 in the UK or 0044 1442 227271 from the Republic of Ireland, and via Email at info@epson.co.uk. They can provide the following information:

- Pre sales information and literature on new EPSON products (also available via our world wide web site at <http://www.epson.co.uk>)
- Where to purchase genuine EPSON consumables, accessories, and options

For Australian Users

EPSON Australia wishes to provide you with a high level of Customer Service. As well as this *User's Guide*, we provide the following sources for obtaining information:

EPSON FAXBACK

EPSON FAXBACK will fax you the latest specifications and pricing for most EPSON products offered in Australia. There is also technical information including details of the latest software and drivers available. Phone (02) 9903 9075 and the system will guide you through a number of choices before faxing the information to your fax machine.

EPSON Bulletin Board System

This is where you can download the latest software and drivers. Visit the BBS to check out the latest versions. If you have a modem, phone (02) 9417 5090.

Internet URL <http://www.epson.com.au>

Access the EPSON Australia World Wide Web pages. Worth taking your modem here for the occasional surf! You can get the same information as offered on the EPSON FAXBACK and the EPSON Bulletin Board plus more.

Your dealer

Don't forget that your dealer can often help identify and resolve problems. The dealer should always be the first call for advice on problems. They can often solve problems quickly and easily as well as give you advice on the next step to take.

B

EPSON Helpdesk

EPSON Helpdesk is provided as a final backup to make sure our clients have access to advice. Operators on the Helpdesk can aid you in diagnosing hardware and software problems. They can also advise you on the latest EPSON products and where the nearest dealer or service agent is located. Many types of queries are answered here.

The Helpdesk numbers are:

Phone: (02) 9903 9040

Fax: (02) 9903 9189

We encourage you to have all the relevant information on hand when you ring. The more information you prepare, the faster we can help solve the problem. This information includes the *User's Guide* for your EPSON product, type of computer, operating system, application programs, and any other information you feel is required.

For Singapore Users

Contact the telephone and fax numbers below:

Phone: (065) 337-7911

Fax: (065) 334-1185

For Hong Kong Users

To obtain technical support as well as other after-sales services, users are welcome to contact EPSON Hong Kong Limited.

Internet home page

EPSON Hong Kong has established a local home page in both Chinese and English on the Internet to provide users with the following information:

- Product information
- Answers to Frequently Asked Questions (FAQs)
- Latest versions of EPSON printer drivers

Users can access our World Wide Web home page at:
<http://www.epson.com.hk>

Electronic bulletin board system

An electronic bulletin board system (BBS) is also available to obtain printer information and the latest versions of printer drivers. You can log on to the following number for the BBS service:

BBS: (852) 2827-4244

Technical Support Hotline

You can also contact our technical staff at the following telephone and fax numbers:

Phone: (852) 2585-4399
Fax: (852) 2827-4383

B

For Philippines Users

To obtain technical support as well as other after sales services, users are welcome to contact the EPSON Philippines Representative Office at the telephone and fax numbers below:

Phone: (632) 813-6552
Fax: (632) 813-6545
BBS: (632) 814-0595

Glossary

additive primary colors

The colors of red, green and blue (RGB) - which give the perception of white when fully added. These are the colors of the color system used with monitors and scanners.

bi-level data

Image data that is composed of 1 bit per pixel. A pixel is represented by a single bit of digital data that can express only 1 (light) or 0 (dark).

bit

Short for binary digit. The smallest unit of data in computer processing. A bit can represent two values: on and off, or 1 and 0.

bit/pixel

The unit that indicates the number of bits allocated for a pixel. The larger the bit value, the more detail of a pixel will be reproduced.

brightness

A scanner function to lighten or darken the output image data.

byte

A unit of information consisting of eight bits. A byte can represent a control code or character.

carriage

A component of the scanner that contains the optical sensor and light source for scanning.

color correction

A method of adjusting the color image data for a particular type of device so that the reproduction results are as close as possible to the original colors.

color separation

A process of converting full-color images into a limited number of primary colors. Additive primary colors (red, green, and blue) are used by the scanner, and the subtractive primary colors (cyan, magenta, and yellow) plus black are used for printing press separation.

ColorSync

Color management system for Macintosh that is designed to help you get WYSIWYG (what you see is what you get) color output. This software displays colors on your screen as they are on the scanned documents, or prints colors as you see them on your screen.

daisy chain

A SCSI bus arrangement that allows several devices to be connected simultaneously in a line to a single computer. See *SCSI*.

default

A set of values used when no other selections have been made. These are sometimes called factory defaults if the original values have not been changed since the scanner has left the factory.

dithering

A process in which software or an output device simulates continuous tones with groups of dots.

document

The item, such as a sheet of paper or a book, that is placed on the document table for the scanner to read.

dpi

Short for dots per inch. A unit of measurement for resolution. The higher the value, the higher the resolution.

dropout color

A color the scanner does not recognize and ignores. You can select and deselect dropout colors in the scanner software.

ESC/I

Abbreviation for EPSON Standard Code for Image scanners. A system of commands that allows you to control image scanners from your software.

ESC/P

Abbreviation for EPSON Standard Code for Printers. A system of commands that allows you to control printers from your software.

exposure

A scanner function that lightens or darkens the scanned image data.

grayscale

Images represented with various shades of gray in addition to black and white.

halftoning

A method of reproducing images with patterns of dots to improve the quality of the output.

home position

The position at the rear (nearest the cover hinge position) of the scanner where the carriage rests before a scanning operation.

ICM

Image Color Matching. Windows color management system designed to help you get WYSIWYG (what you see is what you get) color output. This software displays colors on your screen as they exist on the scanned documents, or prints colors as you see them on your screen.

imagesetter

A device that uses computer files to produce high-resolution text and graphics output on film or paper. These are usually found in service bureaus and printing companies.

impact dot printer

A printer that transfers ink onto the paper by striking an ink ribbon with a number of small pins.

ink jet printer

A printer that transfers ink onto the paper by spraying the ink through a number of small nozzles.

interface

A piece of hardware, a method, or a standard used for connection between or among computer devices.

laser printer

A printer that uses a laser and the electrophotographic method to print a full page at a time. The laser is used to “paint” a charged drum with light, to which toner is applied and then transferred onto paper.

line sequence

A type of color scanning that separates primary colors line by line. The carriage makes only one pass.

marquee

A moveable and adjustable frame that marks the area of an image that will be previewed or scanned.

monochrome

Black and white images, or images represented only by the intensity of luminosity.

OCR

Optical Character Recognition. The technology that allows computers to “read” text from physical objects. OCR requires a graphical representation of text to interpret, which usually comes from a scanned image.

page sequence

The type of color scanning in which the entire image is scanned once for each separate color.

pixel

Short for picture element. Each image is composed of a number of pixels. Pixels are also counted in units of dots.

plain bi-level

Bi-level image data without the halftoning process.

port

An interface channel through which data is transmitted between devices.

primary colors

Basic colors. See *additive primary colors* and *subtractive primary colors*.

resolution

Indication of how finely an image is resolved into pixels. Measured in dots per inch (dpi), pixels per inch (ppi), or samples per inch (spi).

scan

An operation performed by the sensor and the carriage. The image is divided into pixels by scanning.

scanning area

The physical size of the image that can be scanned by the scanner.

SCSI

Small Computer System Interface. This is one method used to connect your computer to peripherals such as scanners, hard disk drives, CD-ROM drives, and so on.

SCSI ID

The numbers that all devices in a SCSI connection (see *daisy chain*) use to identify each other. If the same ID number is used by two devices in the same daisy chain, the devices cannot operate properly.

sRGB

A standard color space used as the default color space within the Windows 98 color management system (ICM 2.0).

subtractive primary colors

The colors of cyan, magenta, and yellow (CMY) - which produce black when mixed in certain amounts. In printing, black is often added to give more definition as mixing of actual inks cannot produce pure black.

terminator

A device that stops electronic signals, and prevents them from proceeding or returning to other devices. This is necessary to stop a signal from continuously bouncing between devices.

threshold

A reference point that is used to determine whether data will be processed as "on" or "off". In the case of color image data, "on" means that a certain color will appear in a pixel or dot, and "off" means that color will not appear there.

tone correction

A method of adjusting the tone curve so that the reproduction results on different types of output devices have gradations similar to the original image.

tone curve

The graph that shows the contrast ratio between the input (original image) and output (image data) in image processing.

USB

A Universal Serial Bus. A hardware interface for connecting low-speed peripherals such as a keyboard, mouse, scanner, or printer to the computer.

USB hub

A device that normally provides four TYPE A sockets to increase the number of USB ports on a PC.

Index

Numerics

- 120/220 (6cm x 9 cm) film, 6-6, 6-9
- 24-bit Color, 4-12, 7-29
- 35mm
 - film holder, 6-5, 6-8
 - negative, 6-5
 - slide, 1-7
 - strip film, 6-8, 6-11
- 4 x 5 inch
 - film, 6-6, 6-9
 - film holder, 6-6, 6-9
- 8-bit Gray, 4-12
- 98 and SCSI, 3-5 to 3-10
- 98 and USB, 3-10 to 3-15

A

- A4, 6-16
- AAS, 1-2
- Accelerator board, 7-29
- AC inlet, 2-6
- Acquire, 4-9, 6-19
- ADF. *See* Automatic Document Feeder
- Auto
 - Area Segmentation (AAS), 1-2, 4-13
 - Exposure, 4-17
- Automatic Document Feeder, 1-7, 4-11, 5-6, 6-13 to 6-23
 - close, 6-14
 - document specifications, 6-22
 - edge guide, 6-16, 6-17
 - installing, 6-14 to 6-15
 - loading document manually, 6-17
 - loading paper, 6-16 to 6-17
 - paper sizes, 6-16
 - precautions, 6-23
 - specifications, A-10
 - unpacking, 6-13

B

- B/W Option, 7-24, 7-25
- B5, 6-16
- B81314*, 1-7, 6-13
- B81317*, 6-2
- Black & White Photo, 4-12
- Button
 - operate, 1-7, 2-6, 2-7, 4-2
 - start, 1-2, 1-7, 4-8, 4-19, Chapter 5

C

- Cable
 - SCSI, 1-3, 2-10, 2-14
 - USB, 1-3, 2-17
- Calibration utility, 3-25 to 3-26
- Carriage, 1-4, 2-7, 7-7
- CE marking specifications, A-5
- Chain, daisy, 2-9, 2-13, 2-15
- Checks, 6-16
- Choosing a place, 2-2
- Close
 - Automatic Document Feeder, 6-14
 - document cover, 4-5
 - Film Adapter, 6-10
 - Scanner Monitor, 3-21, 5-9
- Coarse image, 7-29
- Color
 - Adjustment, 4-17
 - Guide, 7-8
 - millions of, 7-29
 - Photo, 4-12
 - Photo De-screening, 4-12
 - true, 7-29
- Compression, file, 7-29
- Connecting to
 - another SCSI device, 2-9, 2-13
 - Film Adapter, 6-3
 - Macintosh, 2-9
 - PCs, 2-8

- SCSI interface, 2-8, 2-9, 2-13 to 2-14
- USB interface, 2-16 to 2-19
- Connections
 - SCSI, 2-8 to 2-14
 - USB, 2-16 to 2-19
- Connector, option, 6-3, 6-15
- Copy & Fax, 4-13
- Copyright, 4-2
- Cord, power, 1, 1-3, 2-2, 2-4, 2-6, 2-14, 6-14

D

- Daisy chain, 2-9, 2-13, 2-15
- Default SCSI ID, 2-10
- De-screening, Color Photo, 4-12
- Destination, 4-13
- Disk space, 4-10, 4-15, 4-16
- Document
 - Feeder, 5-6
 - Source, 4-11
- Document, placing, 4-2 to 4-5
- Document cover
 - close, 4-5
 - open, 2-7, 4-3
 - reattach, 4-7
 - remove, 4-6, 6-3, 6-14
- Document source setting, 6-7, 6-15
- Document specifications (Automatic Document Feeder), 6-22
- Document table, 4-2, 4-4, 6-3, 6-7, 6-10, 6-17
- Dropout, 4-17

E

- Easy menu, 4-10
- Edge guide, Automatic Document Feeder, 6-16, 6-17
- Electrical specifications, A-4
- Environmental specifications, A-4
- EPSON
 - Instant Photo Print, 1-3, 6-5, 6-8, 6-10
 - PageManager, 3-9, 3-14

- printers, 4-14
- Scanner Monitor, 3-21, 4-19, 5-2, 5-8 to 5-11
- Screen Calibration utility, 3-25 to 3-26
- TWAIN, 1-2, 3-5 to 3-25, 4-2 to 4-17, 6-7, 6-15
- Error
 - indicators, 7-9
 - type, 7-9
- Exposure, 4-17

F

- Fax, 4-13
- File compression, 7-29
- Filename, 4-19
- File Name field, 4-19
- Film Adapter, 1-3, 4-11, 6-2 to 6-12
 - close, 6-10
 - connect, 6-3
 - install, 6-3 to 6-4
 - loading transparencies, 6-7 to 6-10
 - open, 6-7
 - place, 6-3
 - remove, 6-12
 - scanning normal (reflective)
 - documents, 6-12
 - specifications, A-9
 - turn on, 6-4
 - unpacking, 6-2
- Film holders, 1-3, 6-4 to 6-6, 6-8 to 6-11
- Flashing
 - fluorescent lamp, 2-7
 - operate light, 1-6, 2-5, 2-7
- Flatbed, 4-11
- Fluorescent lamp, 2-7
 - replacing, 7-3

G

- Gamma, 4-17
- Gray Balance Intensity, 4-17

H

Halftone, 4-17
Hard disk, 7-28
Help, online, 4-15
Highlight, 4-17
High resolution monitor, 7-29
Hub, USB, 2-17

I

Image
 coarse, 7-29
 Controls, 4-17
 database, 6-13
 saving, 4-18
 scanning, 4-9, 4-10, 4-14
 Type, 4-12, 4-17
Important safety instructions, 1 to 2
Indicator, error, 7-9
Initialization, 2-7
 methods, A-8
Installation
 Automatic Document Feeder, 6-14 to 6-15
 Film Adapter, 6-3 to 6-4
 scanner software, 3-5 to 3-25
 SCSI driver, 2-8
 SCSI interface board, 2-4
Installation software, 3-5 to 3-25
 before, 3-2
Instant Photo Print, 1-3, 6-5, 6-10
Instructions
 safety, 1 to 2
Interface, 3-2, 3-3, 3-4
Interface board, SCSI, 2-4, 2-8, 2-13
Interface specifications
 SCSI, A-6
 USB, A-7

J

Jammed paper, 6-20 to 6-21

L

Lamp, fluorescent, 2-7, 7-3
Laser Printer, 4-14
Legal, 6-16
Letter, 6-16
Lever, release (Automatic Document Feeder), 6-20
Light, operate, 1-6, 2-5, 2-7
Line Art, 4-12
Loading
 document manually (Automatic Document Feeder), 6-17
 paper (Automatic Document Feeder), 6-16 to 6-17
 slides and film, 6-6
Lock, transportation, 1-4, 2-5, 7-7
Locked position, 2-5, 7-7

M

Macintosh, 3-3, 3-4, 3-23 to 3-25, 4-9, 5-10
Macintosh SCSI port, 2-9, 2-14
Maintenance, 7-2 to 7-7
Maintenance and Troubleshooting, Chapter 7
Marquee, 4-16
Memory, 4-10, 4-15, 4-16, 7-28
Millions of colors, 7-29
Moiré, 4-12
Monitor, 7-29
 high resolution, 7-29

N

Non-readable area, 4-4, 7-13
Normal documents, Film Adapter, 6-12

O

OCR, 1-2, 1-7, 4-13, 6-13
Online help, 4-15
Open

- Automatic Document Feeder, 6-17
- document cover, 2-7, 4-3
- Film Adapter, 6-7
- Operate
 - button, 1-7, 2-6, 2-7, 4-2
 - light, 1-6, 2-5, 2-7
- Optical Character Recognition (OCR), 1-2, 1-7, 4-13, 6-13
- Option, Chapter 6
 - connector, 6-3, 6-15

P

- PageManager for EPSON, 3-9, 3-14, 4-18, 4-19, 5-2 to 5-7
- Paper jam, 6-20 to 6-21
- Paper sizes, Automatic Document Feeder, 6-16
- Paper support, 6-15
- Photo, Color, 4-12
- Pixel Depth, 4-17
- Placing
 - document, 4-2 to 4-5
 - Film Adapter, 6-3
 - scanner, 2-2
 - transparencies, 6-7 to 6-10
- Plugging-in, 2-6
- Power cord, 1, 1-3, 2-2, 2-4, 2-6, 2-14, 6-14
- Power-off sequence, 2-16
- Power-on sequence, 2-15
- Precautions, Automatic Document Feeder, 6-23
- Preview button, 4-15
- Preview window, 4-15 to 4-17
- Problems and solutions, 7-8 to 7-26

R

- RAM, 7-28
- Reattach, document cover, 4-7
- Reflective documents, Film Adapter, 6-12
- Release lever, 6-20
- Removing

- document cover, 4-6, 6-3, 6-14
- Film Adapter, 6-12
- film holder, 6-11
- Replacing
 - fluorescent lamp, 7-3
 - SCSI board, 7-27
- Rotary switch, SCSI ID, 1-5

S

- Safety approval specifications, A-5
- Safety information for UK, 3
- Safety instructions, 1 to 2
- Saturation, 4-17
- Save, scanned image, 4-18
- Save As, 4-18
- Scan, 4-2, 4-5
 - ready, 1-6
- Scan Buttons bar, 5-2 to 5-7
- Scanner, 1-1
- Scanner event, 5-12 to 5-14
- Scanner Monitor, EPSON, 3-21, 4-19, 5-2, 5-8 to 5-11
- Scanners and Cameras, 3-10, 3-15, 5-12 to 5-13
- Scanner specifications, A-2 to A-8
- Scanning, 4-5
 - normal (reflective) documents (Film Adapter), 6-12
 - specifications, A-2 to A-8
- Screen, 4-13
 - calibration, 3-25 to 3-26
- SCSI, 3-5, 3-19, 3-23
 - board, 2-4, 2-8, 2-13
 - cable, 1-3, 2-10, 2-14
 - connections, 2-8, 2-9, 2-13 to 2-14
 - port, 2-9, 2-14
 - terminator, 2-10, 2-12, 2-16
- SCSI ID
 - number, 2-10 to 2-11
 - rotary switch, 1-5
- SCSI interface, specifications, A-6
- Select Source, 4-8
- Setup, EPSON TWAIN, 3-5 to 3-25
- Shadow, 4-17

Slides, 6-10
Software
 requirements, 3-2 to 3-4
 scanner, 3-5 to 3-25
Source, Select, 4-8
Specifications
 document (Automatic Document Feeder), 6-22
 electrical, A-4
 environmental, A-4
 Film Adapter, A-9
 safety approvals, A-5
 scanning, A-2 to A-8
 SCSI interface, A-6
 USB interface, A-7
Start button, 1-2, 1-7, 4-8, 4-19, Chapter 5
Switch, terminator, 2-10, 2-12, 2-16
System requirements, 3-2 to 3-4

T

Table, document, 4-2, 4-4, 6-3, 6-7, 6-10, 6-17
Terminator, 2-10, 2-12, 2-16
TET, 1-2
Text Enhancement Technology (TET), 1-2
Threshold, 4-17
Tone Correction, 4-17
TPU for Neg. Film, 4-11
TPU for Pos. Film, 4-11
Transparencies, 6-2, 6-10
Transportation lock, 1-4, 2-5, 7-7
Transporting, 1-4, 2-5, 7-7
Troubleshooting, Chapter 7, 7-8 to 7-26
True color, 7-29
TWAIN Select Source, 4-8

U

Unlocked position, 2-5
Unpacking
 Automatic Document Feeder, 6-13

Film Adapter, 6-2
scanner, 1-3
USB
 cable, 1-3, 2-17
 connections, 2-16 to 2-19
 hub, 2-17
 port, 2-18
USB interface
 specifications, A-7

V

Video card, 7-29

W

Web, 4-13
Windows, 3-2 to 3-3, 3-5 to 3-22
 95, 2-15, 3-15 to 3-20, 5-8 to 5-9
 95 to 98, 3-21 to 3-22
 98, 2-15, 5-8
 NT 4.0, 3-15 to 3-20, 5-8 to 5-9

Z

Zoom preview button, 4-16

EPSON OVERSEAS MARKETING LOCATIONS

EPSON AMERICA, INC.

20770 Madrona Ave.
P.O. Box 2842
Torrance, CA 90509-2842
Phone: (800) 922-8911
Fax: (310) 782-5220

EPSON UK LTD.

Campus 100, Maylands Avenue,
Hemel Hempstead, Herts,
HP2 7TJ, U.K.
Phone: (+44) 01442 261144
Fax: (+44) 01442 227227

EPSON DEUTSCHLAND GmbH

Zülpicher Straße 6,
40549 Düsseldorf Germany
Phone: (0211) 56030
Fax: (0211) 5047787

EPSON FRANCE S.A.

68 bis, rue Marjolin
92300, Levallois-Perret, France
Phone: 33.1.40.87.37.37
Telex: 610657

EPSON AUSTRALIA PTY. LTD.

70 GIBBES STREET, CHATSWOOD 2067 NSW.
Phone: 2-9903-9000
Fax: 2-9903-9177

EPSON SINGAPORE PTE. LTD.

No. 1 Temasek Avenue #36-00
Millenia Tower, Singapore 039192
Phone: (065) 33 77 911
Fax: (065) 33 41 185

EPSON HONG KONG LTD.

Rooms 4706-10, 47/F,
China Resources Bldg.,
26 Harbour Road, Wanchai, Hong Kong
Phone: 2585-4300
Fax: 2827-7083

EPSON TAIWAN TECHNOLOGY & TRADING LTD.

10F, No. 287 Nanking E. Road, Sec. 3,
Taipei, Taiwan, R.O.C.
Phone: (02) 717-7360
Fax: (02) 712-9164

EPSON ITALIA S.p.A.

V.le F.lli Casiraghi 427
20099 Sesto S.Giovanni
MI, Italy
Phone: 2-262331
Fax: 2-2440750

EPSON IBERICA S.A.

Av. de Roma, 18-26
08290 Cerdanyola del Valles
Barcelona, Spain
Phone: 582. 15.00
Fax: 582. 15.55

SEIKO EPSON CORPORATION**(Hirooka Office)**

80 Harashinden, Hirooka
Shiojiri-shi, Nagano-ken
399-0785 Japan

EPSON PORTUGAL, S.A.

R. do Progresso, 471, 1° Perafita
4460 Matosinhos, Portugal
Phone: (02) 996 14 02
Fax: (02) 996 14 11

EPSON

Color Image Scanner

Perfection 1200
User's Guide