

Color Ink Jet Printer

EPSON STYLUS™

PRO 9000



Startup Guide

4009901
S01-00

Where to Find Information

This Startup Guide

Provides you with the basic information you need to start using your EPSON STYLUS PRO 9000 and its optional and consumable products.

Online Guide (may not be available in some countries)

Provides you with detailed information about printing on roll paper or cut sheet media, the control panel, the printer software, and tips that will help you get the results you want.

Online Help

Provides you with detailed information and instructions on the printer software that controls your printer. (Online help will be automatically installed when you install the printer software.) See your *Online Guide* for information on accessing online help.

EPSON® STYLUS™ PRO 9000

Color Ink Jet Printer

All rights reserved. No part of this publication may be reproduced, stored in a retrieval system, or transmitted in any form or by any means, electronic, mechanical, photocopying, recording, or otherwise, without the prior written permission of SEIKO EPSON CORPORATION. The information contained herein is designed only for use with this EPSON printer. EPSON is not responsible for any use of this information as applied to other printers.

Neither SEIKO EPSON CORPORATION nor its affiliates shall be liable to the purchaser of this product or third parties for damages, losses, costs, or expenses incurred by the purchaser or third parties as a result of: accident, misuse, or abuse of this product or unauthorized modifications, repairs, or alterations to this product, or (excluding the U.S.) failure to strictly comply with SEIKO EPSON CORPORATION's operating and maintenance instructions.

SEIKO EPSON CORPORATION shall not be liable for any damages or problems arising from the use of any options or any consumable products other than those designated as Original EPSON Products or EPSON Approved Products by SEIKO EPSON CORPORATION.

SEIKO EPSON CORPORATION shall not be held liable for any damage resulting from electromagnetic interference that occurs from the use of any interface cables other than EPSON Approved Products by SEIKO EPSON CORPORATION.

EPSON is a registered trademark and ESC/P Raster and EPSON STYLUS are trademarks of SEIKO EPSON CORPORATION.

Microsoft and Windows are registered trademarks of Microsoft Corporation.

General Notice: Other product names used herein are for identification purposes only and may be trademarks of their respective owners. EPSON disclaims any and all rights in those marks.

Copyright © 1999 by SEIKO EPSON CORPORATION, Nagano, Japan.



Printed on Recycled Paper.

Startup Guide

Declaration of Conformity

Manufacturer	SEIKO EPSON CORPORATION
Address	3-5, Owa 3-chome, Suwa-shi, Nagano-ken 392-8502 Japan
Representative	EPSON EUROPE B.V.
Address	Prof. J. H. Bavincklaan 5 1183 AT Amstelveen The Netherlands

Declares that the Product:

Product Name	Ink Jet Printer
Model	P130A

Conforms to the following Directive(s) and Norm(s):

Directive 89/336/EEC	EN 55022 Class B EN 61000-3-2 EN 61000-3-3 EN 50082-1 IEC 801-2 IEC 801-3 IEC 801-4
Directive 73/23/EEC	EN 60950

January 1999

H. Horiuchi
President of EPSON EUROPE B.V.

Contents

Declaration of Conformity	2
---------------------------------	---

Safety Instructions

Important Safety Instructions	5
A Few Precautions	6
ENERGY STAR Compliance	8
For United Kingdom Users	8
Use of options	8
Safety information	8
Warnings, Cautions, and Notes	9

Taking a Look at Your Printer

Front view	10
Rear view	10

Chapter 1 Setting up the Printer with Your PC

Connecting the Printer to Your PC	1-2
Using the built-in parallel interface	1-2
Installing the Printer Software on Your PC	1-3
Printer software components	1-3
Installing on Windows 95, 98, and NT 4.0	1-4
Upgrading to Windows 98	1-5
Printing on a Peer-to-Peer Network	1-6
For Windows 95 and 98	1-6
For Windows NT 4.0	1-10

Chapter 2 Setting up the Printer with Your Macintosh

Connecting the Printer to Your Macintosh	2-2
Using the built-in serial interface	2-2
Installing the Printer Software on Macintosh	2-4
Printer software components	2-4
Installing on Macintosh	2-5
Using the Chooser to select your printer	2-7

Chapter 3 Printing and Printer Management

Loading Paper	3-2
Loading roll paper	3-2
Loading cut sheet media	3-7
Printing From Your PC	3-10
Making the printer driver settings	3-10
Cancelling printing from your PC	3-14
Printing From Your Macintosh	3-15
Making the printer driver settings	3-15
Cancelling printing from your Macintosh	3-18

Chapter 4 Checking the Printer's Condition

Using Printer Utilities	4-2
Accessing the printer utilities	4-2
Printing the Nozzle Check Pattern	4-3
Cleaning the Print Heads	4-4
Aligning the Print Heads	4-6

Chapter 5 Using an Optional Interface Card

Available Optional Interface Cards	5-2
Installing the Optional Interface Card	5-2

Safety Instructions

Important Safety Instructions

Read all of these instructions before using your printer. Also be sure to follow all warnings and instructions marked on the printer.

- Do not block or cover the openings in the printer's cabinet.
- Do not insert objects through the slots. Take care not to spill liquid on the printer.
- Use only the type of power source indicated on the printer's label.
- Connect all equipment to properly grounded power outlets. Avoid using outlets on the same circuit as photocopiers or air control systems that regularly switch on and off.
- Avoid electrical outlets controlled by wall switches or automatic timers.
- Keep the entire computer system away from potential sources of electromagnetic interference, such as loudspeakers or the base units of cordless telephones.
- Do not use a damaged or frayed power cord.
- If you use an extension cord with the printer, make sure the total ampere rating of the devices plugged into the extension cord does not exceed the cord's ampere rating. Also, make sure the total ampere rating of all devices plugged into the wall outlet does not exceed the wall outlet's ampere rating.
- Do not attempt to service the printer yourself.

- ❑ Unplug the printer and refer servicing to qualified service personnel under the following conditions:

The power cord or plug is damaged; liquid has entered the printer; the printer has been dropped or the cabinet damaged; the printer does not operate normally or exhibits a distinct change in performance.

- ❑ If you plan to use the printer in Germany, observe the following:

To provide adequate short-circuit protection and over-current protection for this printer, the building installation must be protected by a 16 Amp circuit breaker.

Bei Anschluß des Druckers an die Stromversorgung muß sichergestellt werden, daß die Gebäudeinstallation mit einem 16 A-Überstromschalter abgesichert ist.

A Few Precautions

When using the printer

- ❑ Do not put your hand inside the printer or touch the ink cartridges during printing.
- ❑ Do not move the print heads by hand; otherwise you may damage the printer.
- ❑ Always turn the printer off using the Power button on the control panel. When this button is pressed, the Operate light flashes briefly then goes off. Do not unplug the printer or turn off the power to the outlet until the Operate light stops flashing.
- ❑ Before transporting the printer, make sure the print heads are in the home (far right) position and the ink cartridges are in place.

When handling the ink cartridges

- ❑ Keep ink cartridges out of the reach of children and do not drink.
- ❑ If ink gets on your skin, wash it off with soap and water. If it gets in your eyes, flush them immediately with water.
- ❑ Do not shake ink cartridges as this can cause leakage.
- ❑ Install ink cartridges immediately after removing from the package. Leaving a cartridge unpacked for a long time before use may result in reduced print quality.
- ❑ Once you install an ink cartridge, do not open the clamp or remove the cartridge except to replace it with a new one. The cartridge may become unusable otherwise.
- ❑ Do not use an ink cartridge beyond the date printed on the cartridge carton. For best results, use up the ink cartridges within six months of installation.
- ❑ Do not dismantle the ink cartridges or try to refill them. This could damage the print heads.

When choosing a place for the printer

- ❑ Place the printer on a flat, stable surface that is larger than the printer. The printer will not operate properly if it is tilted or at an angle.
- ❑ Avoid places subject to rapid changes in temperature and humidity. Also keep it away from direct sunlight, strong light, or heat sources.
- ❑ Avoid places subject to shocks and vibrations.
- ❑ Place the printer near a wall outlet where the plug can be easily unplugged.

Note for French-speaking users:

Placez l'imprimante près d'une prise de contact où la fiche peut être débranchée facilement.

ENERGY STAR Compliance



As an ENERGY STAR Partner, EPSON has determined that this product meets the ENERGY STAR guidelines for energy efficiency.

The International ENERGY STAR Office Equipment Program is a voluntary partnership with the computer and office equipment industry to promote the introduction of energy-efficient personal computers, monitors, printers, fax machines, and copiers in an effort to reduce air pollution caused by power generation.

For United Kingdom Users

Use of options

EPSON (UK) Limited shall not be liable against any damages or problems arising from the use of any options or consumable products other than those designated as Original EPSON Products or EPSON Approved Products by EPSON (UK) Limited.

Safety information



Warning:

This appliance must be earthed. Refer to rating plate for voltage and check that the appliance voltage corresponds to the supply voltage.

Important:

The wires in the mains lead fitted to this appliance are coloured in accordance with the following code:

Green and yellow — Earth

Blue — Neutral

Brown — Live

If you have to fit a plug:

As the colours of the mains lead of this appliance may not match coloured markings used to identify the terminals in a plug, please proceed as follows:

The green and yellow wire must be connected to the terminal in the plug which is marked with the letter E or the earth symbol (\perp).

The blue wire must be connected to the terminal in the plug marked with the letter N.

The brown wire must be connected to the terminal in the plug marked with the letter L.

If damage occurs to the plug, replace the cord set or consult a qualified electrician.

Replace fuses only with a fuse of the correct size and rating.

Warnings, Cautions, and Notes



Warnings must be followed carefully to avoid bodily injury.



Cautions must be observed to avoid damage to your equipment.

Notes contain important information and useful tips on the operation of your printer.

Taking a Look at Your Printer

Front view

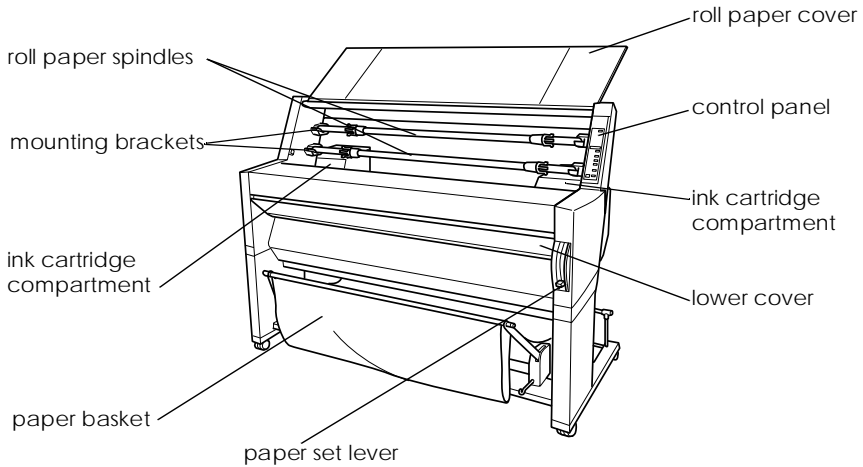

Rear view

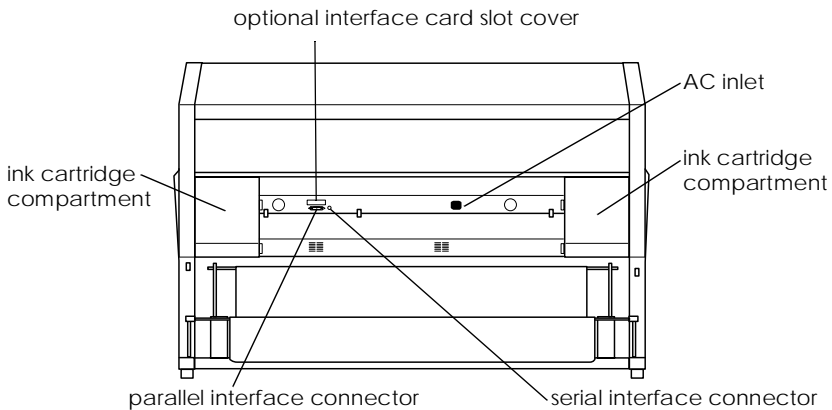

Setting up the Printer with Your PC

Connecting the Printer to Your PC	1-2
Using the built-in parallel interface	1-2
Installing the Printer Software on Your PC	1-3
Printer software components	1-3
Installing on Windows 95, 98, and NT 4.0	1-4
Upgrading to Windows 98	1-5
Printing on a Peer-to-Peer Network	1-6
For Windows 95 and 98	1-6
For Windows NT 4.0	1-10

Connecting the Printer to Your PC

The method you use to connect the printer to your PC depends on whether you want to send print jobs directly to the printer using the printer's built-in parallel interface, or send print jobs to the printer over a network using an optional interface card. For information on using optional interface cards, see Chapter 5, "Using an Optional Interface Card".

To connect the printer to a Macintosh, see Chapter 2, "Setting up the Printer with Your Macintosh".

Using the built-in parallel interface

To use the printer's built-in parallel interface, you will need a shielded, twisted-pair cable. Then follow the steps below to connect the printer to your computer.

1. Make sure both the printer and computer are turned off.
2. Plug the cable connector securely into the printer's interface. Then squeeze the wire clips together until they lock into place on both sides. If your cable has a ground wire, connect it to the ground connector below the interface connector.

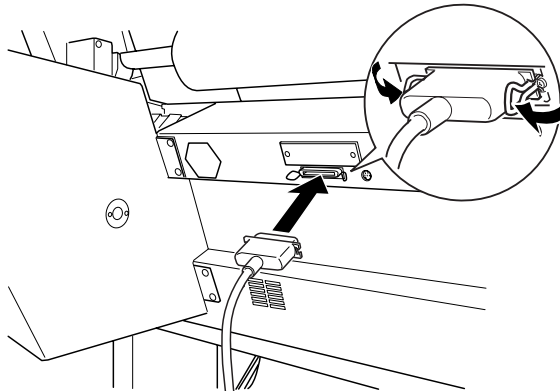

3. Plug the other end of the cable into the computer's parallel port. If a ground wire exists at the computer end of the cable, connect it to the ground connector at the back of the computer.

Now see "Installing the Printer Software on Your PC" on page 1-3. You must install the printer software before using your printer.

Installing the Printer Software on Your PC

After connecting the printer to your computer, you need to install the software included on the "Printer Software for EPSON Stylus PRO 9000" CD-ROM shipped with your printer.

Printer software components

Your printer software includes the following items:

- Printer driver**
The printer driver is the software that runs your printer. With it, you can make settings such as Media Type, Print Quality, and Paper Size.
- Utilities**
The Nozzle Check, Head Cleaning, and Print Head Alignment utilities help you keep your printer in top operating condition.
- EPSON Status Monitor 2**
The EPSON Status Monitor 2 utility notifies you of printer errors and displays printer status information such as the amount of ink remaining. The Status Monitor also guides you when replacing ink cartridges.

Installing on Windows 95, 98, and NT 4.0

Follow these steps to install your printer software:

Note:

If you wish to make a floppy disk version of the printer software included on your CD-ROM, insert the printer software CD-ROM, then click Create Floppy based printer driver/utility disks and follow the on-screen instructions.

1. Insert the software CD shipped with your printer in the CD-ROM drive. The Installer dialog box appears.
2. Double-click Install Printer Driver/Utility to start the printer software installation.
3. When the installation is complete, click OK.

Note:

- If the New Hardware Found screen or any other Wizard appears when you turn on your computer, click Cancel and follow the steps above.*
- Installation time varies depending on your computer.*
- EPSON Status Monitor 2 installation starts automatically. Click Cancel if you do not want to install this utility. If you want to install it later, see “Software” in the Online Guide. If you install EPSON Status Monitor 2, your computer will restart automatically.*

For information on opening and using the printer software, see “Printing From Your PC” on page 3-9. See also “Printer Software” in your *Online Guide*. If you use your printer on a network, see “Printing on a Peer-to-Peer Network” on page 1-6.

Upgrading to Windows 98

When you upgrade from Windows 95 to Windows 98, uninstall the current printer software, then install Windows 98 and the printer software as explained below:

1. Click Start, point to Settings, then click Control Panel.
2. Double-click the Printers icon in the Control Panel window.
3. Right-click your printer icon and click Delete in the dialog box.
4. Follow the messages on your screen.
5. Install the printer driver again. See “Installing on Windows 95, 98, and NT 4.0” on page 1-4.

Printing on a Peer-to-Peer Network

For Windows 95 and 98, see below. For Windows NT 4.0, see “For Windows NT 4.0” on page 1-10.

For Windows 95 and 98

This section tells you how to set up your printer so that other computers on a network can use it.

First, you need to set up the printer as a shared printer on the computer to which the printer is connected. Then, you must signify the network path to the printer from each computer to use the printer, and install the printer software on those computers.

Note:

This section describes how to use your printer as a shared printer on a network. To connect your printer directly to a network without setting it up as a shared printer, consult your network administrator.

Setting up your printer as a shared printer

Follow these steps to share a printer connected directly to your computer with other computers on a network:

1. Click Start, point to Settings, then click Control Panel.
2. Double-click Network.

3. Click File and Print Sharing.
4. Click the I want to be able to allow others to print to my printer(s) check box and click OK.

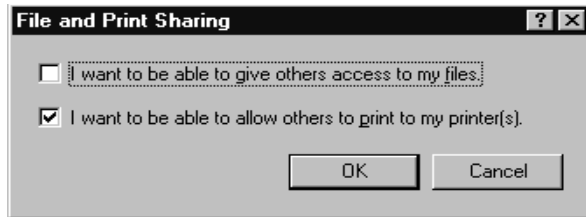

5. In the Network window, click OK.
6. In the Control Panel, double-click Printers.

Note:

- If a dialog box requesting the Windows 95 or 98 CD-ROM appears, insert the CD-ROM in the CD-ROM drive, then follow the messages on the screen.*
 - If a dialog box appears requesting you to restart your computer, do so. Then open the Printer folder, and continue from step 7.*
7. Select your printer, and choose Sharing from the File menu.

8. Click Shared As, enter printer information as needed, then click OK.

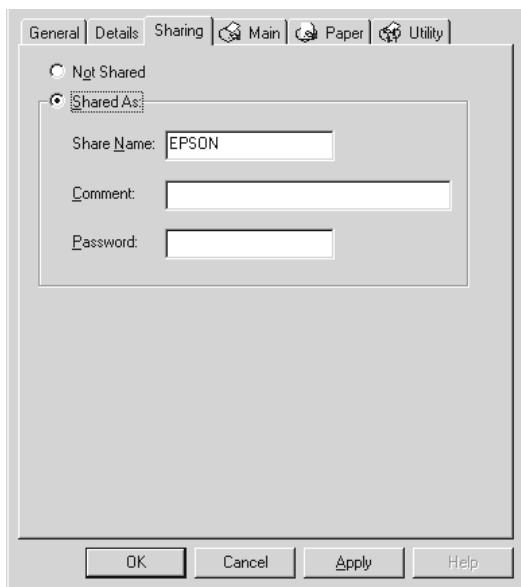

Accessing the printer through a network

To access your printer from another computer on a network, follow these steps.

Note:

Your printer must be set up as a shared resource on the computer to which it is directly connected before you can access it from another computer. For instructions, see “Setting up your printer as a shared printer” on page 1-6.

1. On the computer you want to access the printer from, click Start, point to Settings, and click Printers.
2. Double-click the Add Printer icon.
3. The Add Printer Wizard screen appears. Click Next.

4. Click Network printer, then click Next.

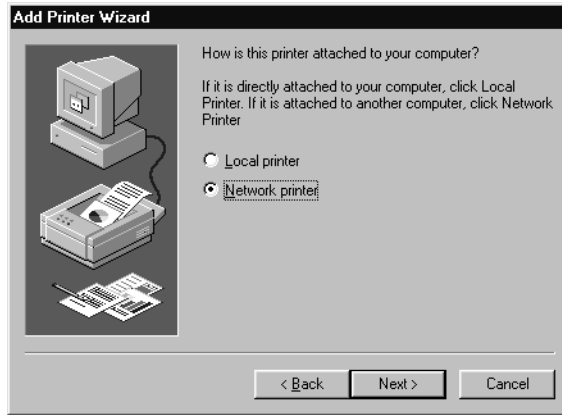

5. Click Browse.

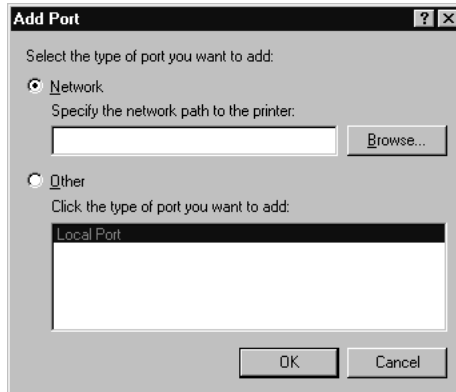

6. Double-click the icon of the computer that is directly connected to the printer. Then click the printer's icon.



7. Click OK and follow the messages on the screen.

For Windows NT 4.0

This section tells you how to set up your printer so that other computers on the network can use it.

First, you need to set up the printer as a shared printer on the computer to which the printer is connected. Then, you must signify the network path to the printer from each computer to use the printer, and install the printer software on those computers.

Setting up your printer as a shared printer

Follow these steps to share a printer that is connected directly to your computer with others on a network.

1. Click Start, point to Settings, and click Printers.
2. Select your printer, then click Sharing on the File menu.

3. Click the Shared radio button and enter the Share Name.

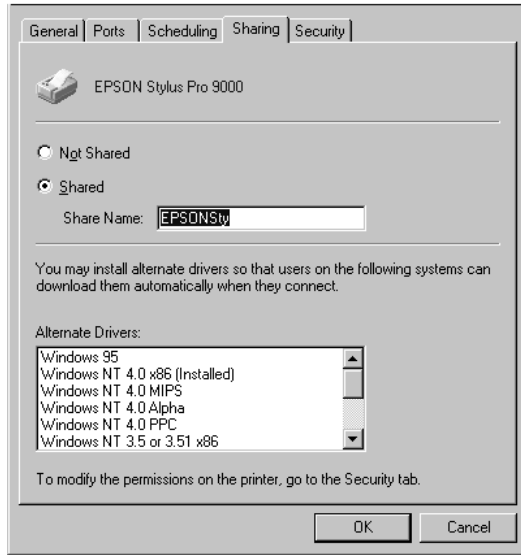

4. Click OK.

Note:

Do not choose any drivers from the Alternate Drivers list.

Accessing the printer through a network

To access your printer from another computer on a network, follow these steps.

Note:

Your printer must be set up as a shared resource on the computer to which it is directly connected before you can access it from another computer. For instructions, see “Setting up your printer as a shared printer” on page 1-10.

1. On each computer from which you want to access the printer, click Start, point to Settings, and click Printers.

2. Double-click the Add Printer icon.
3. Click the Network printer server radio button. Click Next.



4. Double-click the icon of the computer that is directly connected to the printer. Then click the printer's icon.

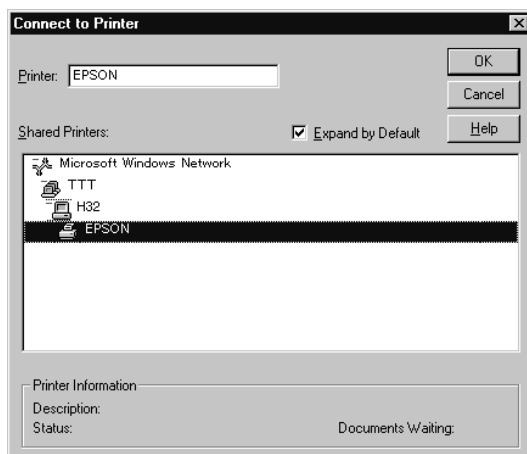

Note:

Be sure to confirm all network settings with the network administrator.

5. Click OK and follow the messages on the screen.

Setting up the Printer with Your Macintosh

Connecting the Printer to Your Macintosh	2-2
Using the built-in serial interface	2-2
Installing the Printer Software on Macintosh	2-4
Printer software components	2-4
Installing on Macintosh	2-5
Using the Chooser to select your printer	2-7

Connecting the Printer to Your Macintosh

The method you use to connect the printer to your Macintosh depends on whether you want to send print jobs directly to the printer using the printer's built-in serial interface, or send print jobs to the printer over a network using an optional interface card. For information on using an optional interface card, see Chapter 5, "Using an Optional Interface Card".

To connect the printer to a PC, see Chapter 1, "Setting up the Printer with Your PC".

Using the built-in serial interface

To use the printer's built-in serial interface, you will need an Apple System Peripheral-8 cable. Then follow the steps below to connect the printer to your Macintosh.

1. Make sure both your printer and Macintosh are turned off.
2. Connect one end of the interface cable to the serial connector on the back of the printer.

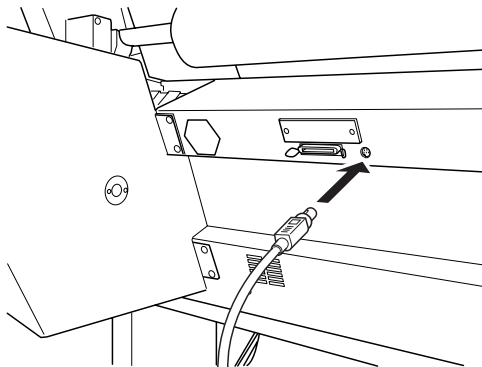

Note:

Use only an Apple System Peripheral-8 cable to connect the printer to your Macintosh. Do not use a LocalTalk cable.

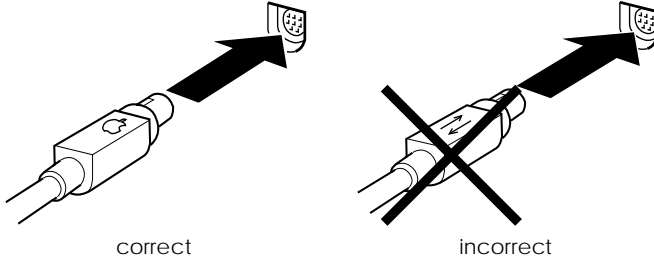

3. Connect the other end of the interface cable to either the modem port or printer port on the Macintosh. The ports are marked with the following icons. (Some Macintosh PowerBook models have only one serial port.)



modem port



printer port

Note:

If your Macintosh has a built-in modem, connect the interface cable to the printer port.

4. Turn on the printer by pressing the Power button.
5. Turn on your Macintosh.

See the next section for instructions on installing the printer software. You must install the printer software before using your printer.

Installing the Printer Software on Macintosh

After connecting the printer to your Macintosh, you are ready to install the printer software included in the “Printer Software for EPSON Stylus PRO 9000” CD-ROM shipped with your printer.

Printer software components

Your printer software includes the following items:

EPSON Printer Driver Package

- SPro 9000**
This is the printer driver software that runs your printer. With it, you can make settings such as Media Type, Print Quality, and Paper Size.
- SPro 9000 (AT)**
This is the printer driver software that gives you control over your printer when used on an AppleTalk network. You can make settings such as Media Type, Print Quality, and Paper Size.
- EPSON Monitor3**
Monitors and manages background printing jobs. You must turn on background printing in the Chooser to use this utility.
- EPSON StatusMonitor**
Keeps track of the current status of your printer, and alerts you when printer errors occur.
- Nozzle Check**
Checks for clogged nozzles.
- Head Cleaning**
Cleans the print heads to maintain the best print quality.

- ❑ **Print Head Alignment**
Adjusts the print heads so that vertical and horizontal lines are aligned.

ColorSync 2.0 and Profiles

Matches the colors in your printout with the colors displayed on your screen automatically. Use this when printing scanned photographs or computer graphics.

Installing on Macintosh



Caution:

Turn off all virus protection programs before you install your printer software.

Follow these steps to install your printer software:

1. Insert the printer software CD shipped with your printer in the CD-ROM drive.
2. The EPSON printer software opens automatically.
3. When the Installer icon appears, double-click the icon.

4. After the initial screen appears, click Continue. The following dialog box appears.



5. If you want to install all of the printer software included on your printer software CD-ROM, make sure the Install Location box shows the correct disk drive and click Install. If disk space is limited, select Custom Install from the pop-up menu and click Serial Driver Package or Network Driver Package. Confirm the destination for installation, then click Install.

Note:

Click the  icon to get information on each component.

6. When a message appears informing you that installation is finished, click Restart to complete the installation and restart your computer.

For information on opening and using the printer software, see “Printing From Your Macintosh” on page 3-14. See also “Printer Software” in the *Online Guide*.

Using the Chooser to select your printer

After you install the printer software, you need to open the Chooser to select your printer. You have to choose the printer only the first time you use it or after you have chosen another printer. Your Macintosh will always print using the last printer selected.

If you are using the serial interface, choose your printer driver as described in the following section, “Using the serial interface”. If your system is connected to an AppleTalk network, see “Using an AppleTalk network” on page 2-8.

Using the serial interface

Follow the steps below to use the serial interface to send print jobs directly to the printer:

1. Make sure the printer is connected to your Macintosh and is turned on.
2. Select Chooser from the Apple menu. Then click the SPro 9000 icon and the port your printer is connected to.

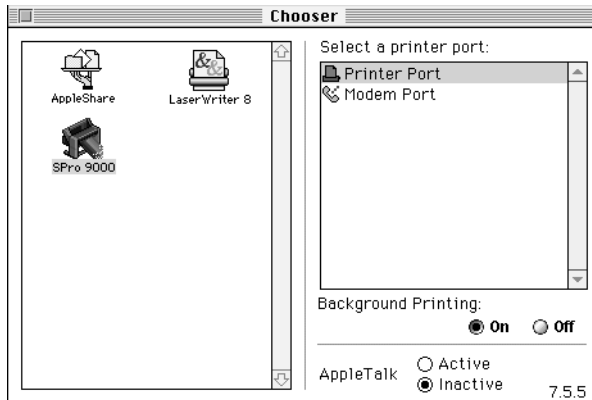

Note:

- ❑ *If you are using an AppleTalk network, an alert message may appear when you click the port. In this case, reselect the other port or make the AppleTalk setting Inactive, then select the port again.*
 - ❑ *If you are using your Macintosh in an Ethernet environment, you can connect your printer to either the printer or modem port and leave the AppleTalk setting Active.*
3. Click the Background Printing radio buttons to turn background printing on or off.

When background printing is on, you can use your Macintosh while it is preparing a document for printing. You must turn on background printing to use the EPSON Monitor3 utility to manage print jobs. For more information, see “Controlling Background Printing” in the *Online Guide*.

4. Close the Chooser.

Using an AppleTalk network

Follow the steps below to use an AppleTalk network to send print jobs to the printer:

1. Make sure the printer is connected to your Macintosh and is turned on.
2. Select Chooser from the Apple menu. Then click the SPro 9000(AT) icon. Select the AppleTalk zone you want to use. A list of all the printers connected to the selected zone appears on the right.

Note:

If you don't see the SPro 9000(AT) icon, use the arrows on the right to scroll through the available icons.

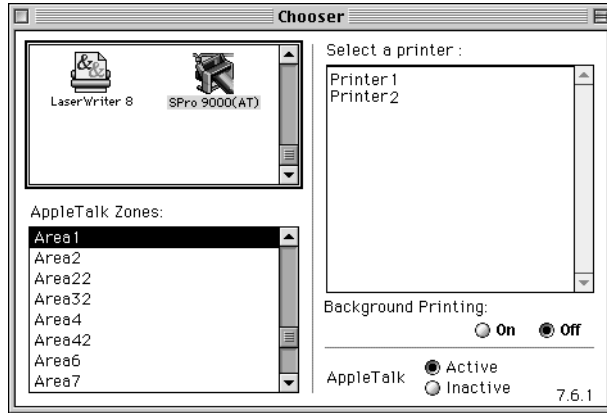

3. Click the name you assigned to your EPSON Stylus Pro 9000.
4. Click OK if the printer model name is correct.

If your printer name does not appear, make sure the printer is turned on and connected properly.

5. Click the Background Printing radio buttons to turn background printing on or off.

When background printing is on, you can use your Macintosh while it is preparing a document for printing. You must turn on background printing to use the EPSON Monitor3 utility to manage print jobs. For more information, see “Controlling Background Printing” in your *Online Guide*.

6. Close the Chooser.

Chapter 3

Printing and Printer Management

Loading Paper	3-2
Loading roll paper	3-2
Loading cut sheet media	3-7
Printing From Your PC	3-10
Making the printer driver settings	3-10
Cancelling printing from your PC	3-14
Printing From Your Macintosh	3-15
Making the printer driver settings	3-15
Cancelling printing from your Macintosh	3-18

Loading Paper

Loading roll paper

To load the roll paper, follow the steps below.

1. Open the roll paper cover. Make sure that the roll paper is attached to the printer properly.



Caution:

Keep your fingers off the printable surface of the media, as fingerprints may reduce printout quality. Whenever possible, use gloves to load paper into the printer.

Note:

If two roll paper spindles are attached to the printer, keep the unused roll wound up using the roll paper belt, to avoid paper jams. To secure the roll paper, tap the end of the roll paper belt lightly on the roll paper. To remove the roll paper belt from the roll paper, simply take off the belt.

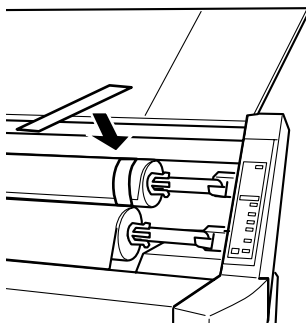

2. Make sure that the printer is on.

3. Press the Paper Source button repeatedly until the Roll Auto Cut light or Roll Cutter Off light is on.



Caution:

If you are loading thick roll paper, select Roll Cutter Off. Paper that is too thick may damage the paper cutter.

4. Make sure the Operate light or Pause light is not flashing, then pull the paper set lever all the way up. The Paper Out light turns on and LOAD PAPER appears on the LCD panel.



Caution:

Do not move the paper set lever up while the Operate light or Pause light is flashing. Otherwise, damage may occur.

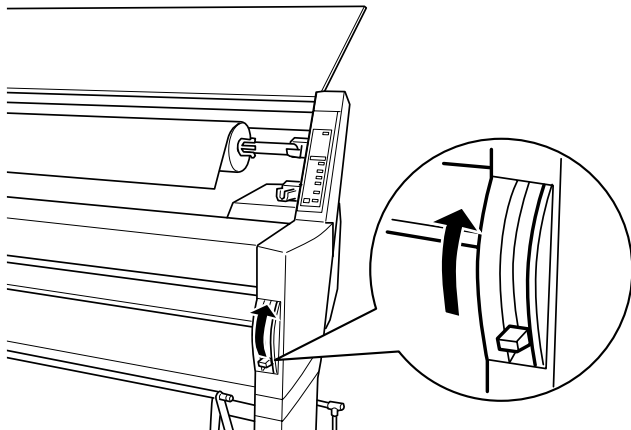

5. Load the paper into the paper insertion slot.

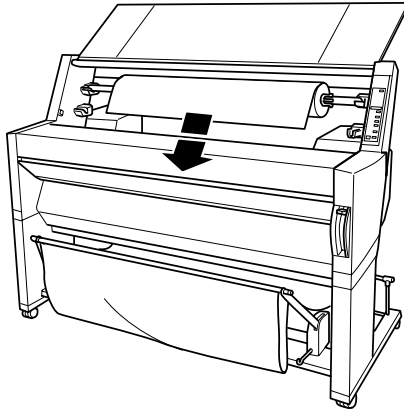

6. Pull the paper down through the paper insertion slot a small way.

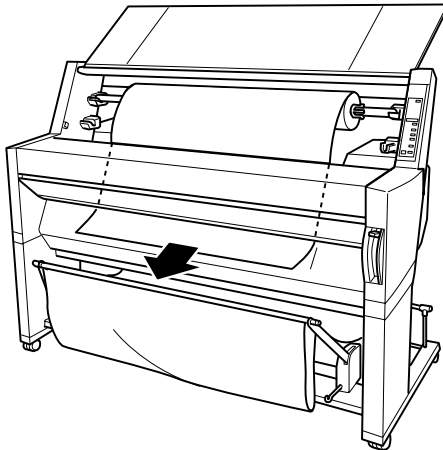

7. Roll back the roll paper to remove the slack. Make sure that the bottom edge of the paper is positioned straightly and in line with the rows of punch holes.

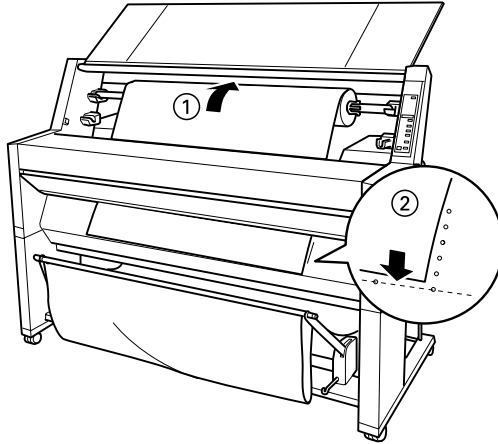

8. Push the paper set lever all the way down, then close the roll paper cover. `PRESS PAUSE BUTTON` appears.

Note:

If the Roll Auto Cut light is on, and the bottom edge of the roll paper was not cut properly after the previous print job, press the Cut/Eject button to recut the edge.

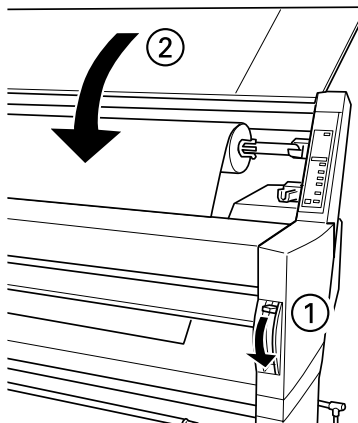

9. Press the Pause button.

The print heads move and the paper feeds into the printing position. **READY** appears on the LCD panel.

Note:

*Even if you do not press the Pause button, the print heads move and paper feeds into the printing position automatically. **READY** appears on the LCD panel.*

Now you are ready to print on roll paper. Make the printer driver settings, then send the print job. See “Printing From Your PC” on page 3-9 or “Printing From Your Macintosh” on page 3-14.

Note:

Allow time for the ink to dry thoroughly after printing to ensure the printout quality.

Loading cut sheet media

To load cut sheet media, follow the steps below.

Note:

If you are printing on thick paper (0.5 mm or thicker), see your Online Guide.



Caution:

Keep your fingers off the printable surface of the media, as fingerprints may reduce printout quality. Whenever possible, use gloves to load paper into the printer.

1. Make sure that the printer is on and the roll paper cover is closed.
2. Press the Paper Source button repeatedly until the Sheet light is on.

3. Make sure the Operate light or Pause light is not flashing, then pull the paper set lever all the way up. The Paper Out light turns on and **LOAD PAPER** appears on the LCD panel.

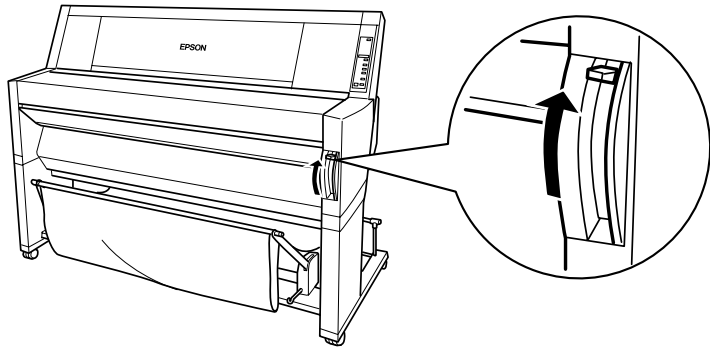

3

4. Load the sheet into the paper insertion slot until it comes out below. Make sure that the right and bottom edges of the paper are straight and in line with the rows of punch holes.

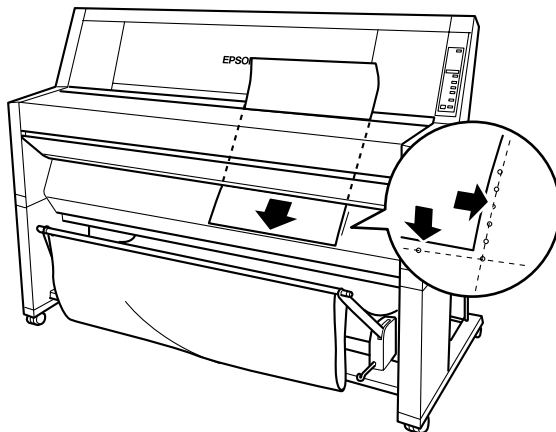

5. Push the paper set lever all the way down, **PRESS PAUSE BUTTON** appears.



Caution:

Do not move the paper set lever up while the Operate light or Pause light is flashing. Otherwise, damage may occur.

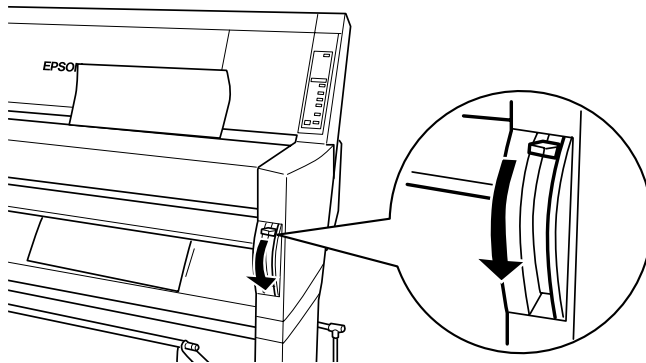

6. Press the Pause button.

The print heads move and the sheet feeds into the printing position. **READY** appears on the LCD panel.

Note:

*Even if you do not press the Pause button, the print heads move and paper feeds into the printing position automatically. **READY** appears on the LCD panel.*

Now you are ready to print on cut sheet media. Make the printer driver settings, then send the print job. See “Printing From Your PC” on page 3-9 or “Printing From Your Macintosh” on page 3-14.

Note:

Allow time for the ink to dry thoroughly after printing to ensure the printout quality.

Printing From Your PC

After loading the paper, you are ready to print your document from your PC.

Note:

To ensure the print quality, you may need to check the printer's condition before you start printing. See Chapter 4, "Checking the Printer's Condition".

3

Making the printer driver settings

To make the basic settings to print your documents, access the Main manu and Paper menu in the printer driver. In the Paper menu, you can set particular settings for printing on roll paper; Auto Rotate, Auto Cut, and Print Page Line.

For details about the printer software, see online help by pressing the Help button in the driver settings window.

1. Click Print on the File menu. The Print dialog box appears.
2. Make sure your printer is selected and then click Properties, or Options. You may need to click a combination of these buttons. The driver settings window appears.

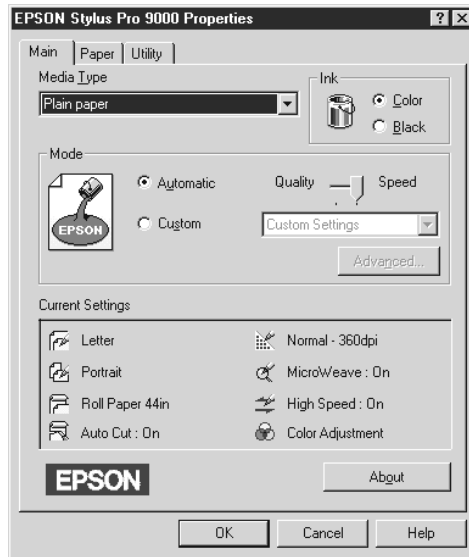

3. Click the Main tab to display the Main menu.
4. Select the media you loaded in the printer from the Media Type list.

Note:

The Media Type setting determines what other settings are available, so you should always make this setting first.

5. In the Ink box, select Color to print in color, or Black to print in black and white.
6. Make sure the Automatic radio button in the Mode box is selected.

Note:

When Automatic is selected, the printer driver takes control of all detailed settings based on the current Media Type setting and Ink setting.

- Adjust Speed and Quality in the Mode box if a slider appears. Drag the slider left or right depending on which is more important. This setting is usually automatically decided in accordance with your Media Type setting.

Note:

Depending on the Media Type you choose, a slider appears in the Mode box.

- Click the Paper tab to display the Paper menu.

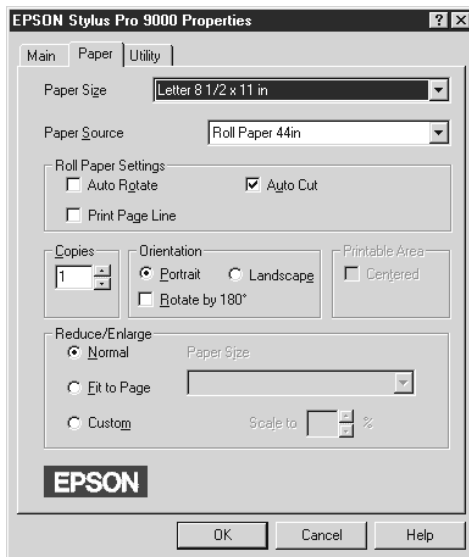

9. Select the paper size you loaded in the printer from the Paper Size list.

Note:

Most Windows applications feature paper size settings that override similar settings in the printer driver.

10. Select the type of paper you loaded in the printer from the Paper Source list.
11. When roll paper is used, set the Roll Paper Settings as required.

Auto Rotate

If your document length is shorter than the printable width of the roll paper, the document will be turned automatically by 90 degrees and printed crosswise when you select Auto Rotate. You can save paper by using this function.

Auto Cut

Roll paper will be cut automatically after printing one page when you select Auto Cut.

Print Page Line

Page lines will be printed on the right side and below the document for manual cutting when you select Print Page Line.

12. Make settings for Copies, Orientation, Printable Area, and Reduce/Enlarge boxes.
13. Click the OK button at the bottom of the window. You return to the Print dialog box (or a similar dialog box).
14. Click Close, OK, or Print to print. You may need to click a combination of these buttons.

While printing, the EPSON Progress Meter will appear, showing the printing progress and the status of your printer.

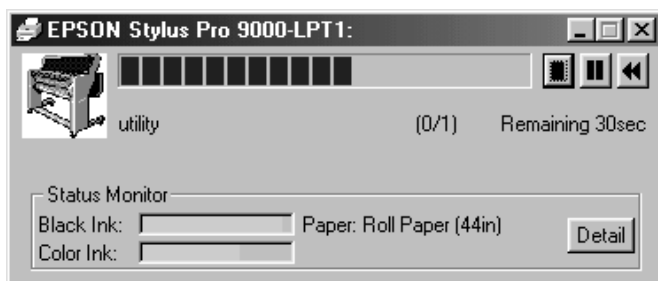

For details, see “Printer Software” in your *Online Guide*.

Canceling printing from your PC

To cancel the printing in progress, press the Stop (■) button on the EPSON Progress Meter.

You can also pause or restart printing. To pause printing, press the Pause (||) button. To resume printing, press this button again. To restart printing, press the Reprint (◀) button.

Printing From Your Macintosh

After loading the paper, you are ready to print your document from your Macintosh.

Note:

To ensure the print quality, you may need to check the printer's condition before you start printing. See Chapter 4, "Checking the Printer's Condition".

Making the printer driver settings

To make the printer driver settings, follow the steps below.

For details about the printer software, see online help by pressing the Help (marked with "?") icon button in the driver setting dialog boxes.

Note:

While many Macintosh applications override the settings made in the printer driver, some do not, so you must verify the settings to get the results you expect.

1. Choose PAGE SETUP from the File menu. This brings up the Page Setup dialog box shown below.

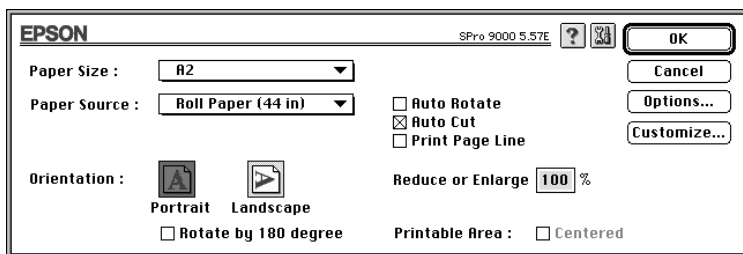

2. Select the paper size you loaded in the printer from the Paper Size list.

3. Select the type of paper you loaded in the printer from the Paper Source list.
4. When roll paper is used, set the Roll Paper Settings as required.

Auto Rotate

If your document length is shorter than the printable width of the roll paper, the document will be turned automatically by 90 degrees and printed crosswise when you select Auto Rotate. You can save paper by using this function.

Auto Cut

Roll paper will be cut automatically after a document is printed when you select Auto Cut.

Print Page Line

Page lines will be printed on the right side and below the document for manual cutting when you select Print Page Line.

5. Make settings for Orientation, Reduce or Enlarge, and Printable Area.
6. After making your settings, click the OK button to close the Page Setup dialog box.

Note:

You cannot print from the Page Setup dialog box. You can only print from the Print dialog box.

7. Choose Print from the File menu. The Print dialog box appears as shown below.

Note:

You can also open the Print dialog box by pressing the Options button in the Page Setup dialog box.

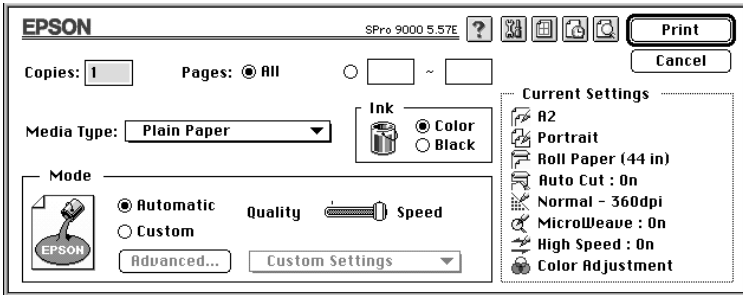

8. Select the media you loaded in the printer from the Media Type list.

Note:

The Media Type setting determines what other settings are available, so you should always make this setting first.

9. In the Ink box, select Color to print in color, or Black to print in black and white.
10. Make sure the Mode option is set to Automatic.

Note:

When Automatic is selected, the printer driver takes control of all detailed settings based on the current Media Type setting and Ink settings.

11. Adjust Speed and Quality in the Mode box if a slider appears. Drag the slider left or right depending on which is more important. This setting is usually automatically decided in accordance with your Media Type setting.

Note:

Depending on the Media Type you choose, a slider appears in the Mode box.



12. Be sure to make the settings for Copies and Pages, then click the Print button to start printing.

Canceling printing from your Macintosh

When background printing is on

1. Press the Power button to turn off the printer.
2. Select EPSON Monitor3 from the application menu.



3. Click the  button, then click the  stop button to cancel the print job.

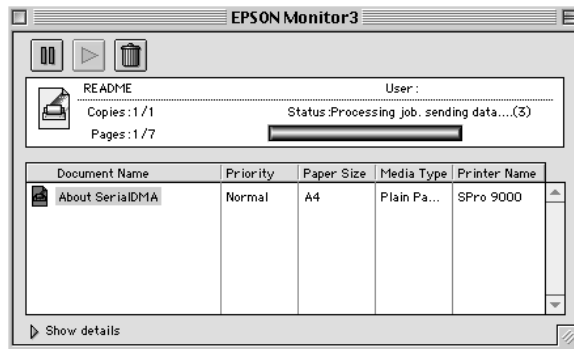

When background printing is off

1. Press the Power button to turn off the printer.
2. Hold down the  key on your keyboard and press the [.] period key to cancel the print job.

Chapter 4

Checking the Printer's Condition

Using Printer Utilities	4-2
Accessing the printer utilities	4-2
Printing the Nozzle Check Pattern	4-3
Cleaning the Print Heads	4-4
Aligning the Print Heads	4-6

Using Printer Utilities

To ensure the print quality, you may need to check the printer's condition using the following utilities from the printer software.

Note:

You can also check from the printer's control panel. See "The Control Panel" in your Online Guide.

- Nozzle Check
- Print Head Cleaning
- Print Head Alignment

Accessing the printer utilities

To access the printer utilities, follow the steps below.

For Windows

1. Double-click the My Computer icon, then double-click the Printers folder.
2. For Windows 95 and 98, right-click your Printer icon, then click Properties. For Windows NT 4.0, right-click your Printer icon, then click Document Defaults. You see the printer software window.

For Macintosh

Click Print on the File menu of your application. Then click the  utility icon in the Print dialog box.

Printing the Nozzle Check Pattern

You can check the print head nozzles from your computer with the Nozzle Check utility in the printer software.

Note:

Do not start the Nozzle Check utility while printing is in progress; otherwise, your printout may be marred.

Follow the steps below:

1. Make sure the printer is turned on and paper is loaded in the printer. (A3 or wider paper)
2. Access the printer software. See “Accessing the printer utilities” on page 4-2.
3. Click the Nozzle Check button.
4. Follow the messages on your screen.

4

The printer prints an operational check page including firmware (ROM) version information and a nozzle check pattern. The nozzle check pattern will resemble one of the two samples shown below:

Nozzle Check Pattern

Good condition: Print heads do not require cleaning.



Poor condition: Print heads require cleaning.

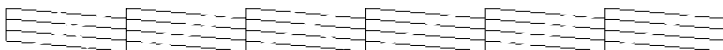

Note:

Actual tests are printed in color.

If any segments of printed lines are missing in your nozzle check pattern, ink nozzles are clogged and the print heads require cleaning.



Caution:

Make sure that the nozzle check pattern printing is complete before you start printing. Otherwise, print quality may decline.

Cleaning the Print Heads

You can execute the head clean from your computer using the Head Cleaning utility in the printer software, as explained in the following steps.

Note:

- Print head cleaning uses ink. To avoid wasting ink, clean the print heads only if print quality declines.*
- Use the Nozzle Check utility to confirm that the print heads need to be cleaned, as this uses only a little ink.*
- When an Ink Out light is flashing (ink low) or on (ink out) in the printer, you cannot clean the print heads before replacing the appropriate ink cartridge first.*
- Do not start the Head Cleaning or Nozzle Check utilities while printing is in progress; otherwise, your printout may be marred.*

Follow the steps below:

1. Make sure the lights on the control panel do not indicate that ink is low or ink is out.
2. Access the printer software. See “Accessing the printer utilities” on page 4-2.
3. Click the Head Cleaning button.

4. Follow the messages on your screen.

The Pause light of the printer flashes during the cleaning cycle, which takes about three minutes to complete.



Caution:

Never turn off the printer until the cleaning cycle is finished and the Pause light has stopped flashing. Doing so may damage the printer.

5. When the Pause light is on, click Print nozzle check pattern (Windows) or the Confirmation button (Macintosh) in the Head Cleaning dialog box, or print a few lines from a document, to confirm that the heads are clean.

Nozzle Check Pattern

Good Condition: Print head clean was successful.



Poor condition: Print heads require further cleaning.



Note:

Actual tests are printed in color.

In the check pattern, if you find that segments are still missing from the test lines, you may need to repeat head cleaning and print the nozzle check pattern again.

If print quality does not improve even after repeating this procedure several times, contact your dealer.

Aligning the Print Heads

You can align the print heads using the Print Head Alignment utility in the printer software.

Note:

- ❑ *Do not start the Print Head Alignment utility while printing is in progress; otherwise, your printout may be marred.*
- ❑ *Alignment pattern printing requires 1.5 m roll paper.*

Follow the steps below:

1. Make sure the printer is turned on, and the EPSON special roll paper you plan to use is loaded in the printer. (297 mm or wider roll paper)

Note:

If you plan to use paper other than EPSON special paper, you may need to align the print heads using the SelecType settings. See “Paper Handling” in your Online Guide.

2. Access the printer software. See “Accessing the printer utilities” on page 4-2, depending on your system.
3. Click the Utility tab in the printer software window (Windows) or the  utility icon in the Print or Page Setup dialog box (Macintosh), then click the Print Head Alignment button.
4. Follow the messages on your screen. The printer prints the head alignment patterns.

- Choose the set number that has the smallest gap in each alignment pattern. In the example below, set number 4 has the smallest gaps.

patterns #1-5, #7, #9-12

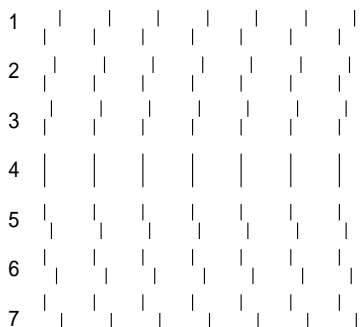

patterns #6, #8 only

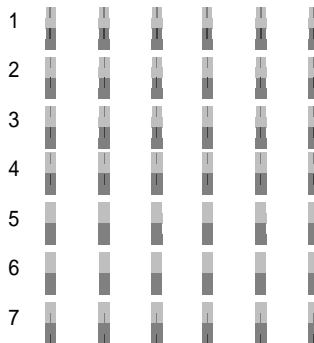

4

- Select the number you chose in step 5 (for example, number 4), then click Finish.

Print Head Alignment

A A Look at the alignment sheet.

Find the patterns on the printed sheet that are vertically aligned, and select the number of those alignment patterns from the lists below.

If you cannot find an aligned pattern, select the number of the most aligned pattern, and click "Realignment". The alignment sheet will be printed again.

#1	<input type="text" value="4"/>	#6	<input type="text" value="4"/>	#11	<input type="text" value="4"/>
#2	<input type="text" value="4"/>	#7	<input type="text" value="4"/>	#12	<input type="text" value="4"/>
#3	<input type="text" value="4"/>	#8	<input type="text" value="4"/>		
#4	<input type="text" value="4"/>	#9	<input type="text" value="4"/>		
#5	<input type="text" value="4"/>	#10	<input type="text" value="4"/>		

Note:

If the set with the smallest gap is unclear and cannot be selected, click the Realignment button and repeat from step 5.

Chapter 5

Using an Optional Interface Card

Available Optional Interface Cards	5-2
Installing the Optional Interface Card	5-2

Available Optional Interface Cards

The optional Ethernet Interface Cards shown below let you use your printer on a network. The Ethernet card automatically detects the protocols on your network, so you can print from Windows 95, 98 and NT 4.0, and Macintosh on an AppleTalk network.

Type B Ethernet Interface Card (10BASE-T)	C82362*
Type B Ethernet Interface Card (100BASE-TX)	C82363*

Note:

The asterisk in the product number is a substitute for the last digit which varies by country.

Installing the Optional Interface Card

To install an optional interface card, follow these steps:

Note:

Before you install the optional interface card, see the documentation that comes with the card for setup information.

1. Make sure the printer is turned off.
2. Make sure that the power cord is unplugged from the electrical outlet.



Warning:

Do not install the interface card when the printer is connected to an electrical outlet, as damage may occur.

3. Disconnect the existing interface cable, if necessary.

4. Use a cross-head screwdriver to remove the two screws securing the shield plate to the optional interface slot; then lift off the plate. Be sure to keep the screws; you may need to use them again when you re-install the shield plate.

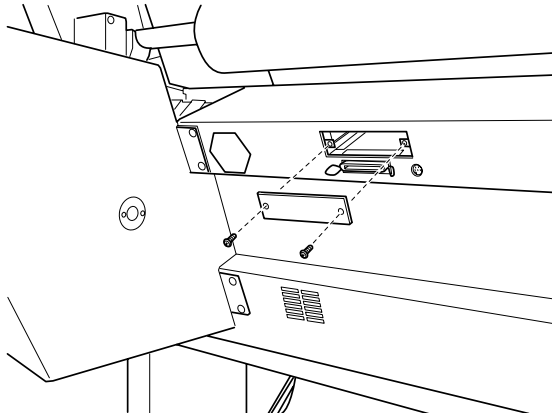

5. Set any DIP switches and jumpers on the card, if necessary. See the interface card's documentation for details.
6. Slide the interface card along the slots on both sides of the interface compartment. Push it in firmly to fully insert the connector at the rear of the interface card into the printer's internal socket.

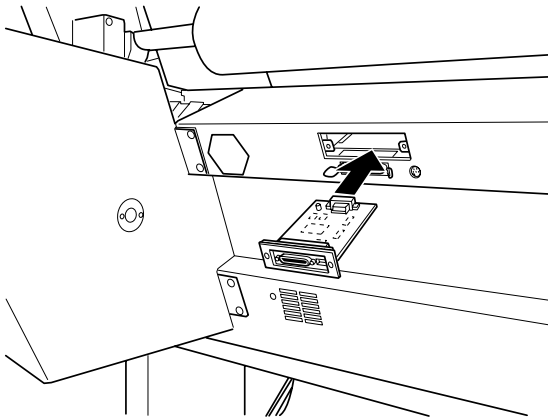

7. Secure the interface card in the slot with the two screws included with the interface card.
8. Connect a compatible interface cable to the interface card and to your computer. If the cable has a ground wire, secure it with one of the screws.

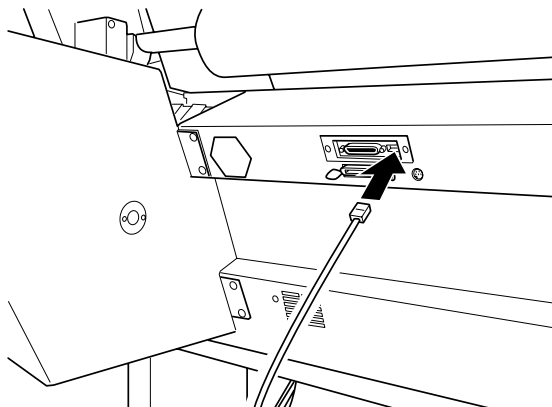

Also, if you are using more than one computer, reconnect the other interface cable.

9. Make sure the printer is turned off. Then plug in the power cord.

To remove an interface card, follow the above steps in reverse order.

EPSON OVERSEAS MARKETING LOCATIONS

EPSON AMERICA, INC.

20770 Madrona Ave.
P.O. Box 2842
Torrance, CA 90509-2842
Phone: (800) 922-8911
Fax: (310) 782-5220

EPSON UK LTD.

Campus 100, Maylands Avenue,
Hemel Hempstead, Herts,
HP2 7TJ, U.K.
Phone: (+44) 01442 261144
Fax: (+44) 01442 227227

EPSON DEUTSCHLAND GmbH

Zülpicher Straße 6,
40549 Düsseldorf Germany
Phone: (0211) 56030
Fax: (0211) 5047787

EPSON FRANCE S.A.

68 bis, rue Marjolin
92300, Levallois-Perret, France
Phone: 33.1.40.87.37.37
Telex: 610657

EPSON AUSTRALIA PTY. LTD.

70 GIBBES STREET, CHATSWOOD 2067 NSW.
Phone: 2-9903-9000
Fax: 2-9903-9177

EPSON SINGAPORE PTE. LTD.

No. 1 Temasek Avenue #36-00
Millenia Tower, Singapore 039192
Phone: (065) 33 77 911
Fax: (065) 33 41 185

EPSON HONG KONG LTD.

Rooms 4706-10, 47/F,
China Resources Bldg.,
26 Harbour Road, Wanchai, Hong Kong
Phone: 2585-4300
Fax: 2827-7083

EPSON TAIWAN TECHNOLOGY & TRADING LTD.

10F, No. 287 Nanking E. Road, Sec. 3,
Taipei, Taiwan, R.O.C.
Phone: (02) 717-7360
Fax: (02) 712-9164

EPSON ITALIA S.p.A.

V.le F.lli Casiraghi 427
20099 Sesto S.Giovanni
MI, Italy
Phone: 2-262331
Fax: 2-2440750

EPSON IBERICA S.A.

Av. de Roma, 18-26
08290 Cerdanyola del Valles
Barcelona, Spain
Phone: 582. 15.00
Fax: 582. 15.55

SEIKO EPSON CORPORATION**(Hirooka Office)**

80 Harashinden, Hirooka
Shiojiri-shi, Nagano-ken
399-0785 Japan

EPSON PORTUGAL, S.A.

R. do Progresso, 471, 1º Perafita
4460 Matosinhos, Portugal
Phone: (02) 996 14 02
Fax: (02) 996 14 11

Color Ink Jet Printer
EPSON STYLUS™
PRO 9000
Startup Guide