

**SC-S80600 Series**  
**SC-S80600L Series**  
**SC-S60600 Series**  
**SC-S60600L Series**  
**SC-S40600 Series**

# **User's Guide**

---

## Copyrights and Trademarks

---

### **Copyrights and Trademarks**

No part of this publication may be reproduced, stored in a retrieval system, or transmitted in any form or by any means, electronic, mechanical, photocopying, recording, or otherwise, without the prior written permission of Seiko Epson Corporation. The information contained herein is designed only for use with this Epson printer. Epson is not responsible for any use of this information as applied to other printers.

Neither Seiko Epson Corporation nor its affiliates shall be liable to the purchaser of this product or third parties for damages, losses, costs, or expenses incurred by the purchaser or third parties as a result of accident, misuse, or abuse of this product or unauthorized modifications, repairs, or alterations to this product, or (excluding the U.S.) failure to strictly comply with Seiko Epson Corporation's operating and maintenance instructions.

Seiko Epson Corporation shall not be liable for any damages or problems arising from the use of any options or any consumable products other than those designated as Original Epson Products or Epson Approved Products by Seiko Epson Corporation.

Seiko Epson Corporation shall not be held liable for any damage resulting from electromagnetic interference that occurs from the use of any interface cables other than those designated as Epson Approved Products by Seiko Epson Corporation.

EPSON and EPSON EXCEED YOUR VISION or EXCEED YOUR VISION and their logos are registered trademarks or trademarks of Seiko Epson Corporation.

Microsoft®, Windows®, and Windows Vista® are registered trademarks of Microsoft Corporation.

Mac, macOS are registered trademarks of Apple Inc.

Intel® is a registered trademark of Intel Corporation.

Bemcot™ is a trademark of Asahi Kasei Corporation.

YouTube® and the YouTube logo are registered trademarks or trademarks of YouTube, LLC.

PANTONE®, Colors generated may not match PANTONE-identified standards. Consult current PANTONE Publications for accurate color. PANTONE®, and other Pantone trademarks are the property of Pantone LLC. Pantone LLC, 2019.

*General Notice: Other product names used herein are for identification purposes only and may be trademarks of their respective owners. Epson disclaims any and all rights in those marks.*

© 2019 Seiko Epson Corporation

## Contents

# Contents

## Copyrights and Trademarks

## Introduction

Printer Parts. . . . .	6
Front Section. . . . .	6
Right view. . . . .	9
Inside. . . . .	10
Back. . . . .	12
Ink unit (SC-S80600L Series/SC-S60600L Series). . . . .	13
Control panel. . . . .	15
Understanding the Display. . . . .	16
Features. . . . .	19
Realizing High Productivity. . . . .	19
High Print Quality. . . . .	19
Superior Ease of Use. . . . .	19
Notes on Usage and Storage. . . . .	20
Installation space. . . . .	20
Notes when using the printer. . . . .	21
Notes when not using the printer. . . . .	21
Notes on handling ink cartridges/ink supply units. . . . .	22
Notes on Handling the Ink Unit (SC-S80600L Series/SC-S60600L Series). . . . .	23
Handling Media. . . . .	23
Notes on Usage of WH/MS Ink (SC-S80600 Series/SC-S80600L Series). . . . .	23
Introducing the Supplied Software. . . . .	25
Supplied software. . . . .	25
Pre-installed software. . . . .	26
Using Epson Edge Dashboard. . . . .	27
Starting Procedure. . . . .	27
Closing Procedure. . . . .	27
Using EPSON Software Updater. . . . .	27
Checking software update availability. . . . .	27
Receiving update notifications. . . . .	28
Using Remote Manager. . . . .	28
Starting Procedure. . . . .	28
Closing Procedure. . . . .	28
Uninstalling Software. . . . .	28
<b>Basic Operations</b>	
Notes on loading media. . . . .	30
Notes on Loading Media. . . . .	30
Loading media. . . . .	30

Using the Auto Take-up Reel Unit. . . . .	36
Attaching the Roll Core. . . . .	37
Take-up with the Printed Side Facing Out. . . . .	39
Take-up with the Printed Side Facing In. . . . .	41
Settings for Loaded Media. . . . .	44
Saving New Media Settings. . . . .	45
Type and Summary of Media Settings. . . . .	45
Easy Media Setup Procedure. . . . .	46
Optimization of media settings (Media Adjust). . . . .	48
Notes on Media Adjust. . . . .	49
When selecting Adhesive Vinyl or Banner. . . . .	49
When selecting anything other than Adhesive Vinyl or Banner. . . . .	49
Removing the Take-up Roll. . . . .	51
Printing the Amount of Media Remaining. . . . .	52
Cutting Media. . . . .	52
Removing Media. . . . .	53
Before Printing. . . . .	54
Changing settings during printing. . . . .	55
Changing the Heater Temperature and Drying Settings. . . . .	55
Correcting Banding. . . . .	55
Checking Details for the Remaining Amount of Ink and Wiper Units. . . . .	56
Printable area. . . . .	57

## Maintenance

When to Perform Various Maintenance Operations. . . . .	60
Cleaning Locations and Cleaning Timing. . . . .	60
Locations of Consumables and Replacement Timing. . . . .	61
Other maintenance. . . . .	61
What You'll Need. . . . .	63
Precautions regarding maintenance. . . . .	63
Daily Cleaning. . . . .	64
Performing Regular Cleaning. . . . .	65
Using ink cleaner. . . . .	65
Moving the Print Head. . . . .	66
Cleaning Around the Print Head. . . . .	67
Cleaning Around the Caps. . . . .	67
Finishing Cleaning. . . . .	71
Shaking and Replacing Ink Cartridges (SC-S80600 Series/SC-S60600 Series/SC-S40600 Series). . . . .	71

## Contents

Shaking. . . . .	71
Replacement procedure. . . . .	72
Shaking and Replacing Ink Supply Units (SC-S80600L Series/SC-S60600L Series). . . . .	74
Shaking. . . . .	74
Replacement procedure. . . . .	75
Disposing of Waste Ink. . . . .	77
Preparing and Replacement Timing. . . . .	77
Waste Ink Counter. . . . .	77
Replacing the Waste Ink Bottle. . . . .	77
Replacing Maintenance Parts. . . . .	79
Preparing and Replacement Timing. . . . .	79
Replacing Maintenance Parts. . . . .	80
Replacing the media edge plates. . . . .	82
Replacement procedure. . . . .	82
Disposal of used consumables. . . . .	84
Disposal. . . . .	84
Checking for clogged nozzles. . . . .	85
Ways to Check for Clogs. . . . .	85
Printing nozzle check patterns. . . . .	86
Head Cleaning. . . . .	86
Types of Head Cleaning. . . . .	86
Head cleaning procedure. . . . .	87
Long-term Storage (Pre-storage Maintenance). . . . .	88
Pre-storage Maintenance Timing. . . . .	88
Performing Pre-storage Maintenance. . . . .	89
Restarting use of the printer. . . . .	89
Change Color Mode (SC-S80600 Series/SC-S80600L Series only). . . . .	90
Notes on Changing. . . . .	90
Timing when Changing from 10 to 9 Colors. . . . .	90
Change Color Mode procedure. . . . .	91
Cleaning inside the front cover. . . . .	91
Cleaning pressure rollers. . . . .	91
Applying Grease to the Carriage Rod. . . . .	92
Location of Carriage Rod and Used Pad. . . . .	92
Greasing procedure for carriage rod A. . . . .	93
Greasing procedure for carriage rod B. . . . .	95
Storing Grease. . . . .	95

### Using the Control Panel Menu

Menu Operations. . . . .	97
Menu List. . . . .	98
Details of the Menu. . . . .	104
The Media Setup Menu. . . . .	104
The Printer Setup Menu. . . . .	108
The Maintenance Menu. . . . .	111

The Printer Status Menu. . . . .	114
The Preferences Menu. . . . .	114

### Problem Solver

When a Message is Displayed. . . . .	116
When a Maintenance Call/Service Call Occurs. . . . .	118
Troubleshooting. . . . .	119
You cannot print (because the printer does not work). . . . .	119
The printer sounds like it is printing, but nothing prints. . . . .	119
The prints are not what you expected. . . . .	120
Media. . . . .	121
Others. . . . .	123

### Appendix

Options and Consumable Products. . . . .	124
Ink cartridges. . . . .	124
Ink Supply Unit. . . . .	127
Maintenance Items. . . . .	130
PANTONE Color Explanation. . . . .	132
Supported Media. . . . .	132
Moving and Transporting the Printer. . . . .	133
Moving the Printer. . . . .	133
Transport. . . . .	134
Media Settings List for Each Media Type. . . . .	135
System Requirements. . . . .	136
Epson Edge Dashboard. . . . .	136
Epson Edge Print. . . . .	137
Remote Manager. . . . .	137
Specifications Table. . . . .	139

### Where To Get Help

Technical Support Web Site. . . . .	142
Contacting Epson Support. . . . .	142
Before Contacting Epson. . . . .	142
Help for Users in North America. . . . .	143
Help for Users in Europe. . . . .	143
Help for Users in Taiwan. . . . .	143
Help for Users in Australia/New Zealand. . . . .	144
Help for Users in Singapore. . . . .	144
Help for Users in Thailand. . . . .	145
Help for Users in Vietnam. . . . .	145
Help for Users in Indonesia. . . . .	145
Help for Users in Hong Kong. . . . .	146
Help for Users in Malaysia. . . . .	146
Help for Users in India. . . . .	146

**Contents**

Help for Users in the Philippines. . . . . 147

**Software License Terms**

Open Source Software Licenses. . . . . 148

    Bonjour. . . . . 148

    OpenSSL License/Original SSLeay License. . . . . 153

Other Software Licenses. . . . . 157

    Info-ZIP copyright and license. . . . . 157

## Introduction

---

# Introduction

---

## Printer Parts

---

### Front Section

The illustration shows the SC-S60600 Series.

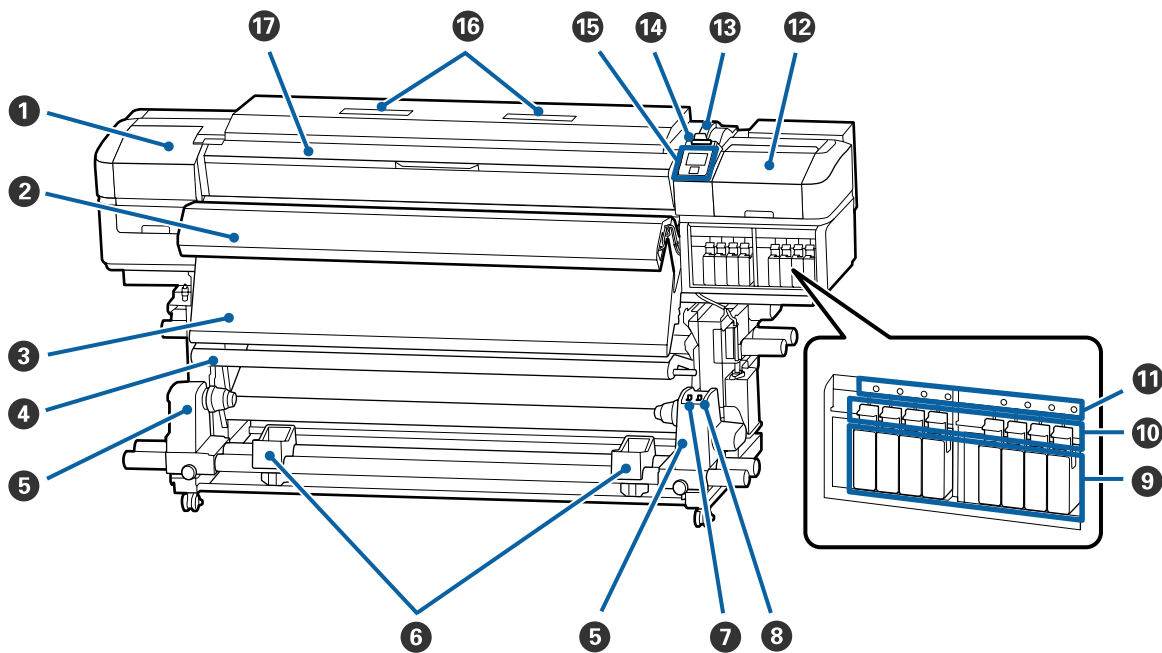

**1 Maintenance cover (left)**

Open this cover to clean the area around the print head. Normally closed when using the printer.

[“Cleaning Around the Print Head” on page 67](#)

**2 Additional Print Drying System**

The heater can be used to rapidly dry ink after printing. This is an option for the SC-S80600 Series/SC-S80600L Series/SC-S40600 Series.

[Additional Print Drying System Setup Guide](#)

**3 After heater**

The heater can be used to rapidly dry ink after printing.

[“Changing the Heater Temperature and Drying Settings” on page 55](#)

**4 Tension bar**

The tensioner maintains tension to prevent the media sagging as it is taken up.

[“Using the Auto Take-up Reel Unit” on page 36](#)

## Introduction

### 5 Roll core holder

Place the roll core for media take-up on these holders. There are same parts on both the left and the right.

 [“Using the Auto Take-up Reel Unit” on page 36](#)

### 6 Roll support

Rest media temporarily on these supports when removing the take-up roll. There are same parts on both the left and the right.

### 7 Auto switch

Use this switch to select the auto take-up direction. If Off is selected, the paper is not taken up.

### 8 Manual switch

Use this switch to select the manual take-up direction. The selected option takes effect when the Auto switch is in the Off position.

### 9 Ink cartridges

The SC-S40600 Series only has cartridge slots on the right. Not available for the SC-S80600L Series/SC-S60600L Series.

Install all ink cartridges into each slot. Depending on the maintenance operation being performed, follow the instructions on the control panel screen to install the Cleaning Cartridge.

### 10 Lock levers

Raise the levers to unlock the ink cartridges prior to removal. Lower the levers to lock the cartridges in place after insertion.

Not available for the SC-S80600L Series/SC-S60600L Series.

### 11 Cartridge check lamp

This lamp lights when an ink cartridge error occurs.

On : An error occurred. Check the contents of the error on the control panel's screen.

Off : No error.

Not available for the SC-S80600L Series/SC-S60600L Series.

### 12 Maintenance cover (right)

Open this cover to clean the area around the caps. Normally closed when using the printer.

 [“Cleaning Around the Caps” on page 67](#)

### 13 Media loading lever

After loading media, lower the media loading lever to keep the media in place. Raise the lever to release the media prior to removal.

### 14 Alert lamp

This lamp lights or flashes when an error occurs.

Light/Flash : An error occurred. The type of error is indicated by how the lamp lights or flashes. Check the contents of the error on the control panel's screen.

Off : No error.

## Introduction

### 15 Control panel

 [“Control panel” on page 15](#)

### 16 Air filter

These filters absorb ink mist as air passes through the printer. The air filters are consumable items.

Replace the wiper unit at the same time.

 [“Replacing Maintenance Parts” on page 79](#)

### 17 Front cover

Open when loading media, cleaning the inside of the printer, or removing jammed media. Normally closed when using the printer.



## Introduction

### Right view

The illustration shows the SC-S80600L Series.

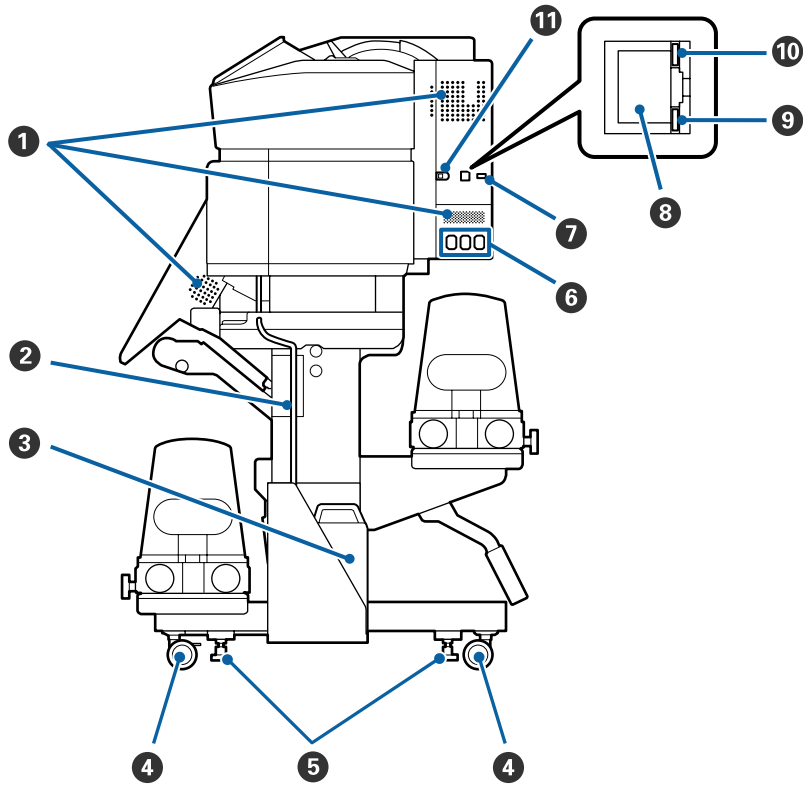

**1 Airflow vents**

Allows air to flow into the printer. Do not obstruct these vents.

**2 Waste ink tube**

Tubes for ejecting waste ink. Be sure the end of this tube is in the Waste Ink Bottle while the printer is in use.

**3 Waste Ink Bottle**

Waste ink collects in this bottle. The shape varies according to the model being used.

Replace it with a new Waste Ink Bottle when a message is displayed on the control panel prompting you to do so.

 [“Disposing of Waste Ink” on page 77](#)

**4 Casters**

There are two casters on each leg. Once installation is complete, the front casters should be kept locked while the printer is in use.

**5 Adjusters**

When installing on a carpeted floor or a sloping floor, check level gauge of the printer and adjust these to keep the printer stable.

 [Setup Guide](#)

## Introduction

### 6 AC inlet #1/AC inlet #2/AC inlet #3

Connect the power cables supplied with the printer to #1 and #2. Be sure to connect both cables.

Connect the power cable supplied with the ink unit to #3. #3 is not available for the SC-S80600 Series/SC-S60600 Series/SC-S40600 Series.

### 7 Optional port

Not available for the SC-S80600 Series/SC-S60600 Series/SC-S40600 Series. Connect the connection cable supplied with the ink unit.

### 8 LAN port

Connects the LAN cable. Use a shielded twisted pair cable (category 5 or higher).

### 9 Data lamp

The data lamp lights or flashes to indicate the network connection status and whether the printer is receiving data.

On : Connected.

Flashing : Connected. Receiving data.

### 10 Status lamp

The color indicates the network's communication speed.

Red : 100Base-TX

Green : 1000Base-T

### 11 USB port

Connects the USB cable.

## Inside

Dirt on any of the following parts may reduce print quality. Regularly clean or exchange these parts as described in the chapters listed in the reference sections below.

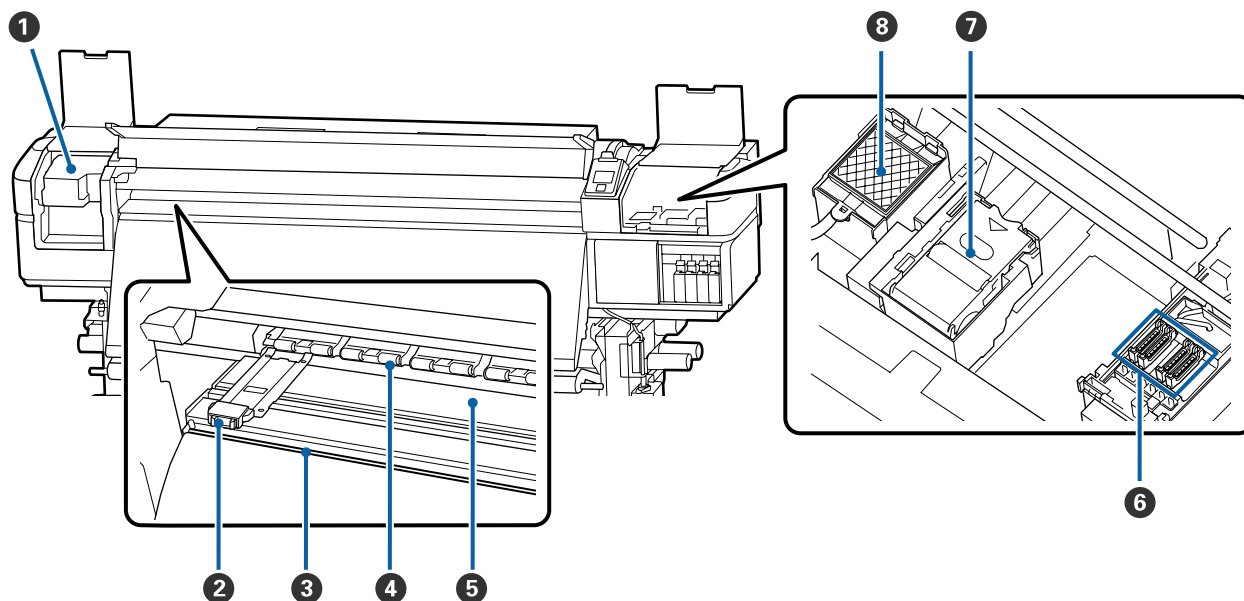

## Introduction

### 1 Print head

The print head prints by moving left and right while emitting ink. Clean at least once a month.

 [“Cleaning Around the Print Head” on page 67](#)

### 2 Media edge plates

The media edge plates prevent the media riding up and keeps fibers on the cut edge of the media from touching the print head. Position the plates at either side of the media before printing.

 [“Loading media” on page 30](#)

### 3 Cutter groove

Pass the blade of a cutter (available in the market) down this groove to cut media.

 [“Cutting Media” on page 52](#)

### 4 Pressure rollers

These rollers press down on the media during printing.

 [“Daily Cleaning” on page 64](#)

### 5 Platen heater

The platen heater ensures that the ink adheres evenly.

 [“Changing the Heater Temperature and Drying Settings” on page 55](#)

 [“Daily Cleaning” on page 64](#)

### 6 Caps

Except during printing, these caps cover the print head nozzles to prevent them drying out. The SC-S80600 Series/SC-S80600L Series/SC-S60600 Series/SC-S60600L Series have 2 blocks. Clean at least once a month.

 [“Cleaning Around the Caps” on page 67](#)

### 7 Wiper unit

The wiper removes ink from the surface of the print head nozzles. The wiper unit is a consumable item. Replace when a message is displayed on the control panel prompting you to do so.

 [“Replacing Maintenance Parts” on page 79](#)

### 8 Flushing pad

Ink is discharged onto this pad during flushing. This is a consumable; Replace the wiper unit at the same time.

 [“Replacing Maintenance Parts” on page 79](#)

## Introduction

### Back

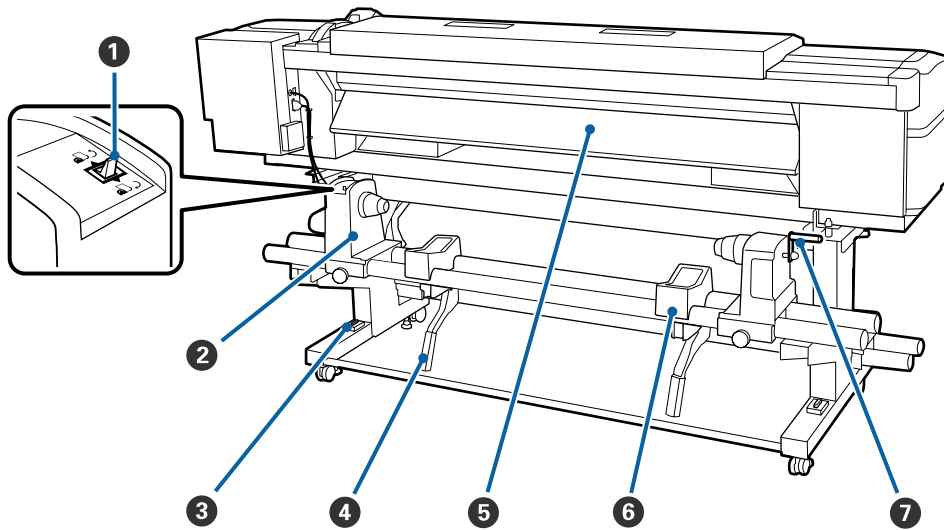

**1 Drive switch**

The drive switch is used to feed the media during loading and to rewind the media for replacement.

**2 Roll holder**

Place media on these holders. There are same parts on both the left and the right.

**3 Level gauge**

When installing on a carpeted floor or a sloping floor, check the horizontal level of the printer. There are same parts on both the left and the right.

*📖 Setup Guide*

**4 Lift lever**

If the media to be mounted on the roll holders seems heavy, use these levers to raise the media effortlessly to the level of the roll holders. There are same parts on both the left and the right.

**5 Pre-heater**

Heats the media before printing so that the print area is not subject to sudden changes in temperature.

**6 Roll support**

Rest media on these supports before placing it on the roll holders. There are same parts on both the left and the right.

**7 Handle**

After placing media on the right roll holder, rotate the handle to press the holder and apply pressure to the roll core.

Introduction

**Ink unit (SC-S80600L Series/SC-S60600L Series)**

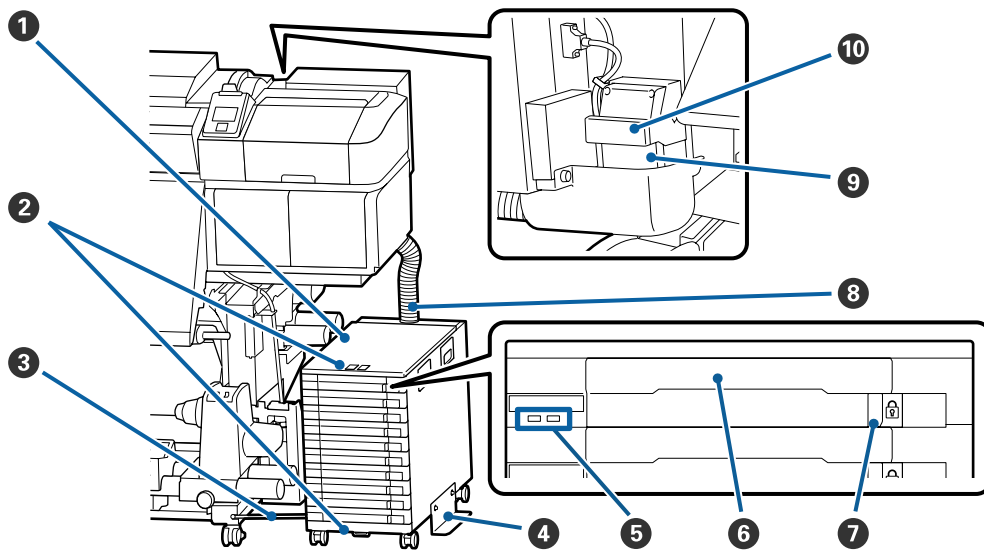

**1 Ink Unit**

The ink unit supplies ink to the printer. Insert the ink supply units in all the trays.

**2 Security cable attachment**

Pass a commercially available security cable through the upper and lower mounting parts to prevent the ink supply units from being stolen.

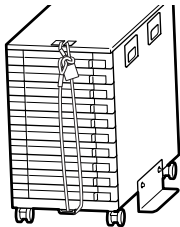

**3 Fixing wire**

When in use, be sure to use screws to fasten the fixing wire to the front and back of the printer's legs. The ink tube may break if you move the ink unit while it is connected to the printer without being fastened with the fixing wire.

**4 Overturn-prevention plate**

Be sure the ink unit is used with an overturn-prevention plate attached to both sides to prevent the ink unit from overturning.

## Introduction

### 5 LED lamp

The LED lamp indicates the status of the ink unit and the ink supply units inserted into their trays by lighting or flashing, as shown below.

Lit blue : Ink is being supplied to the printer. Do not pull out the tray.

Flashing blue : It is time to stir the ink supply unit. Pull out the tray and shake it.

 [“Shaking” on page 74](#)

Lit or flashing orange: An error or warning has occurred. The type of error or warning is indicated by how the lamp lights or flashes. You can check the details of the error or warning on the control panel's screen.

Off : No error. You can pull out the tray if needed.

### 6 Tray

Insert the ink supply unit for the color indicated on the label. Place all of the trays in the ink unit.

### 7 Lock switch

To pull out a tray, unlock it by shifting the lock switch to the right. After placing the tray in the ink unit, lock it by shifting the lock switch to the left.

### 8 Ink tube

This tube supplies ink from the ink supply units to the printer.

### 9 Ink tube connector

This connector connects the ink tube and the printer. This is used with the ink tube and printer connected normally, except for when transporting the printer.

 [“Moving and Transporting the Printer” on page 133](#)

### 10 Connector lock levers

Locks the ink tube connector. Do not use this after it is locked in setup.

**Introduction**

**Control panel**

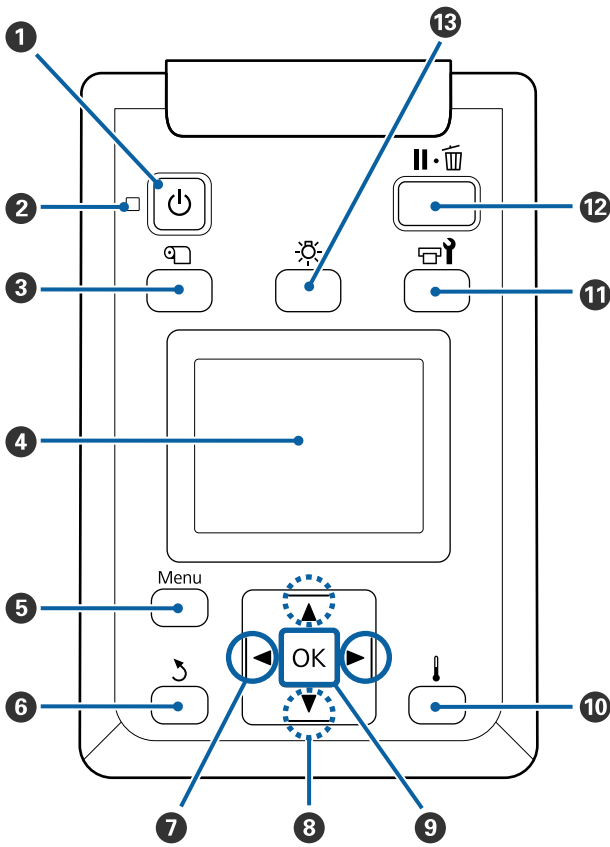

**1** **button (power button)**  
Turns the power on and off.

**2** **light (power light)**  
The printer's operational status is indicated by a lit or flashing light.

On : The power is on.

Flashing : The printer is receiving data or performing head cleaning or other operations during shut-down.

Off : The power is off.

**3** **button (Media Setup button)**

Pressing this button displays the Media Setup menu on the screen to perform **Feed To Cut Position**, **Media Remaining**, **Select Media**, **Customize Settings**, and **Easy Media Setup**.

[“The Media Setup Menu” on page 104](#)

If you press this while printing, you can adjust the media feed.

[“Correcting Banding” on page 55](#)

**4** **Display**  
Displays the printer's status, menus, error messages, and so on. [“Understanding the Display” on page 16](#)

**5** **Menu button**  
Press this button to display menus. [“Using the Control Panel Menu” on page 97](#)

**6** **button (back button)**  
Press this button to exit to the previous menu when options are displayed. [“Menu Operations” on page 97](#)

**7** **buttons (left and right arrow buttons)**  
Use to position the cursor when performing such tasks as entering a **Setting Name** or **IP address** in the setup menu.

**8** **buttons (up and down buttons)**

## Introduction

- ❑ When the media loading lever is lowered  
Press the ▼ button to feed the media and the ▲ button to rewind it.  
Press and hold the button to speed up the media feed. If you are using the SC-S80600L Series/SC-S60600L Series, give the button 1 short press to allow the media to be fed in 0.4 mm increments. This helps when fine-tuning the alignment of the media.  
Note that when the ▲ button is used to rewind, the media will stop when its edge reaches the starting print position. Rewind can be resumed by releasing the button and then pressing it again.
- ❑ When the media loading lever in a raised position, the button to rewind media depends on how the loaded media is rolled.  
Printable Side Out: Press the ▲ button.  
Printable Side In: Press the ▼ button.  
Keep the button pressed to rewind the media up to 25 cm.
- ❑ When the menus are displayed, these buttons can be used to select menu items and options. [☞ “Menu Operations” on page 97](#)

### 9 OK button

- ❑ Pressing this button when a menu item is highlighted displays options for the selected item.
- ❑ Pressing this button when an option is highlighted selects the highlighted item or performs the selected operation.
- ❑ Pressing this button while the alert buzzer is sounding stops the buzzer.

### 10 [ ] button (heating/drying button)

Pressing this button displays the Heating & Drying menu on the screen to perform **Start Preheat**, **Heater Temperature**, **Drying Time Per Pass**, and **After Heater Feed**. If the Additional Print Drying System (supplied with the SC-S60600 Series/SC-S60600L Series; optional with other models) is attached, you can also adjust **Additional Dryer** settings. These options can be adjusted during printing.

[☞ “Changing the Heater Temperature and Drying Settings” on page 55](#)

### 11 ☞ button (maintenance button)

Pressing this button displays the Maintenance menu on the screen to perform **Nozzle Check**, **Cleaning**, **Head Maintenance**, **Replace Ink Bottle**, **Head Washing**, and **Pre-Storage Maint.**. This button is disabled during printing.

[☞ “The Maintenance Menu” on page 111](#)

### 12 II button (pause/cancel button)

- ❑ The printer enters pause status if this is pressed while printing. To release the pause status, press the II button again, or select **Pause Cancel** on the screen and then press the OK button. To cancel print jobs being processed, select **Job Cancel** on the screen and then press the OK button.
- ❑ Pressing this button when menus are displayed closes the menus and returns the printer to ready status.

### 13 [ ] button (light button)

Press when the internal light is on to turn off the light.

Press when the internal light is off to turn on the light.

However, when you press the button during an operation that does not allow the light to turn on, the light remains off.

## Understanding the Display

The illustration shows the display for the SC-S60600 Series.

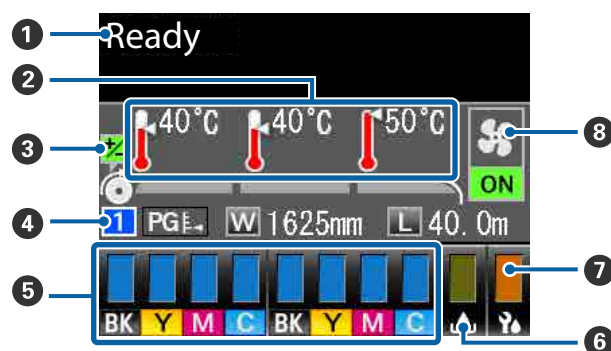

### 1 Messages

Displays the printer's status, operation, and error messages.

[☞ “When a Message is Displayed” on page 116](#)



## Introduction

### 2 Heater temperature

From left to right, this display shows the settings for the pre-heater, platen heater, and after heater. The thermometer icons give a rough indication of the current temperatures of the heaters.

 : The heater has reached the selected temperature.

 : The heater has not reached the selected temperature.

### 3 Feed adjustment information during printing

This information is displayed when the adjustment value is specified during printing.

 [“Correcting Banding” on page 55](#)

### 4 Media info

From left to right, this display shows the number for the selected media, platen gap, media width, and media remaining.

The selected platen gap is shown as follows.

 : 1.6

 : 2.0

 : 2.5

The media remaining is not displayed if **OFF** is selected for **Length** in the **Media Remaining** menu.

 [“Media Remaining” on page 104](#)

### 5 Status of the ink cartridge/ink supply unit

Displays the approximate level of remaining ink and the current status. When ink runs low or an error occurs, the display changes as shown below.

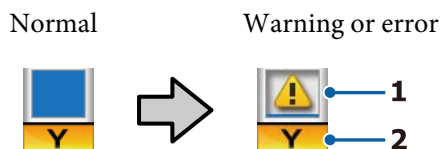

#### 1 Status indicators

These indicate the status of the ink cartridges/ink supply units, as follows.

 : Ready to print. The height of the indicator changes with the level of ink remaining in the cartridge/ink supply unit.

 : Ink is low. You need to prepare a new ink cartridge/ink supply unit.

 : The level of ink remaining has reached the limit. Replace the old ink cartridge/ink supply unit with a new one.

 : The ink cartridge/tray is not locked. Lock it.

 : No ink cartridge/ink supply unit is inserted. Insert an ink cartridge/ink supply unit, and then lock the ink cartridge/tray.

 : An error occurred. Check the message on the screen, and clear the error.

 : A cleaning cartridge/cleaning ink supply unit is inserted. The height of the indicator changes with the level of cleaning liquid remaining in the cartridge/cleaning ink supply unit.

## 2 Ink color codes

SC-S80600 Series/SC-S80600L Series

OR : Orange

LK : Light Black

BK : Black

C : Cyan

M : Magenta

Y : Yellow

R : Red

LC : Light Cyan

LM : Light Magenta

WH : White

## Introduction

- MS : Metallic Silver
- CL : Cleaning Cartridge/Cleaning Ink Supply Unit

SC-S60600 Series/SC-S60600L Series/SC-S40600 Series

- BK : Black
- Y : Yellow
- M : Magenta
- C : Cyan

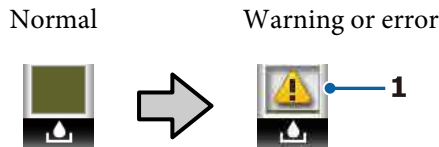

### 6 Waste Ink Bottle status

Displays the approximate amount of space available in the Waste Ink Bottle. The display changes as shown below when the waste ink bottle is nearly full or an error occurs.



#### 1 Status indicators

The status of the Waste Ink Bottle is shown as follows.

-  : No error. The indicator changes to show the amount of space available.
-  : The Waste Ink Bottle is almost full. Ready a new Waste Ink Bottle.
-  : The Waste Ink Bottle is full. Replace with a new Waste Ink Bottle.

### 7 Wiper unit status

Displays the remaining amount for the wiper.

-  : The indicator decreases according to the amount remaining.

### 8 Additional Print Drying System status

Displays the settings for the Additional Print Drying System (optional for the SC-S80600 Series/SC-S80600L Series/SC-S40600 Series).

- No icon : Not installed, or it is not installed correctly.



- : The drying fan is enabled.



- : The drying fan is not enabled. To start the fan, select **Additional Dryer** for **ON** in the setup menu.

[☞ “Changing the Heater Temperature and Drying Settings” on page 55](#)

**Note:**

You can check 5 to 7 in a little more detail from Level on the setup menu.

[☞ “The Printer Status Menu” on page 114](#)

## Introduction

# Features

This large-format color ink jet printer supports roll media 1626 mm (64 inches) in width. The main features of this printer are described below.

---

## Realizing High Productivity

### Triple Heaters

The three heaters listed below support improved productivity and print quality.

The pre-heater: Warms media before printing to protect the print area from sudden changes in temperature.

The platen heater: Ensures that the ink adheres evenly.

The after heater: Can be used to rapidly dry ink after printing.

### Media Feeding Unit Accommodates up to 45 kg Rolls

The Media Feeding Unit can handle high-capacity rolls with external diameters of up to 250 mm and weights of up to 45 kg ensuring that media requires less frequent replacement.

### Auto Take-up Reel Unit Comes Standard

The auto take-up reel unit automatically takes up printed media cleanly, with no wrinkles. You'll find it comes in handy for banner printing, high-volume print jobs, and continuous overnight printing.

### High-Capacity Ink Cartridges/Ink Supply Units

High-capacity ink cartridges/ink supply units are provided to ensure high productivity. This also reduces the nuisance of frequent ink cartridge/ink supply unit replacements.

### High-Speed Printing

The SC-S60600 Series/SC-S60600L Series are equipped with 2 heads for faster printing. High speeds are supported by using 2 ink cartridges/ink supply units for each color of ink.

### Additional Print Drying System Available

The Additional Print Drying System (supplied with the SC-S60600 Series/SC-S60600L Series; optional with other models) can be used for increased drying performance and improved productivity. When using 10 color mode in SC-S80600 Series/SC-S80600L Series, we recommend using this system because WH/MS ink can take a while to dry.

---

## High Print Quality

### Smooth Gradations, High-Fidelity Color Reproduction

The SC-S80600 Series/SC-S80600L Series are equipped for light-colored inks (LK, LC, and LM) to reduce graininess and smooth the gradations. Also, the use of OR and R ink increases the color gamut for high-fidelity color reproduction.

This achieves a print quality at a level sufficient for fine art, car wraps, and indoor display advertising that can be inspected at close range.

### Equipping WH/MS inks

By equipping the SC-S80600 Series/SC-S80600L Series with WH or MS ink, a variety of print effects becomes available.

The WH ink is high opacity, making it suitable for masking on transparent media (window graphics). Other inks can be printed over WH or MS inks (ink layering), preventing color inks showing through and allowing for a variety of metallic colors.

---

## Superior Ease of Use

### Media Installation and Take up a Snap

The roll and roll core holders require no spindles, eliminating the need to attach spindles before installing media. Just bring the media to the printer and install it directly. Never having to juggle long spindles makes installing media a snap even where space is limited.

In addition to roll supports that give you a place to rest media during installation, the printer offers lift levers that allow heavy media to be effortlessly raised to the level of the roll holders.

### Easily register optimum print settings for the media being used

A variety of settings are provided allowing you to perform optimum printing according to the size and type of the media being used. When **Easy Media Setup** is enabled on the setup menu, you can register a variety of settings quickly and easily according to the media type.

## Introduction

When using the "Epson Edge Dashboard" software, you can download and set print setting files (EMX) provided by Epson. An EMX is a print settings file for each media type and includes print information that is necessary to print correctly on commercially available media, such as settings for media registered to the printer, ICC profiles to be used in RIP, the number of passes, and the resolution. You can easily perform optimum printing by registering the media settings to your printer, and then specifying the print information using RIP.

### Ease of Maintenance

Print quality can only be ensured through maintenance. Cleaning operations have been reduced through wipers built into the printer. Also, the design of this printer leaves plenty of space for maintenance, making maintenance easy.

You can prevent nozzles becoming clogged or automatically improve clogging symptoms through periodic cleaning and running the auto nozzle check function.

### Changing the color mode to suit your needs

You can change to the following color modes.

- 10 color mode (WH) <=> 10 color mode (MS)
- 10 color mode (WH) <=> 9 color mode
- 10 color mode (MS) <=> 9 color mode

 ["Change Color Mode \(SC-S80600 Series/SC-S80600L Series only\)" on page 90](#)

### E-Mail Error/Warning Notification

EpsonNet Config with Web Browser system built into the printer's network interface offers e-mail notification. Once configured for e-mail notification, the printer will send errors and warnings to selected e-mail addresses, ensuring peace of mind when the printer is left unmanned during overnight operation and in other similar situations.

Starting EpsonNet Config (with Web Browser)  [Network Guide](#) (pdf)

### Lamp and Buzzer Error Alerts

When an error occurs, a buzzer will sound and the alert lamp will light. The large alert lamp is highly visible, even at a distance.

A buzzer sounds simultaneously to prevent time wasted while stoppages due to errors go unnoticed.

### High-Speed USB/Gigabit Ethernet

The printer comes equipped with high-speed USB and 100 Base-TX/1000 Base-T network interfaces.

## Notes on Usage and Storage

### Installation space

Make sure that you secure the following space, clear of any other objects, so that paper ejection and consumable replacement are not obstructed.

See the "Specifications Table" for the external dimensions of the printer.

 ["Specifications Table" on page 139](#)

#### SC-S80600 Series/SC-S60600 Series/SC-S40600 Series

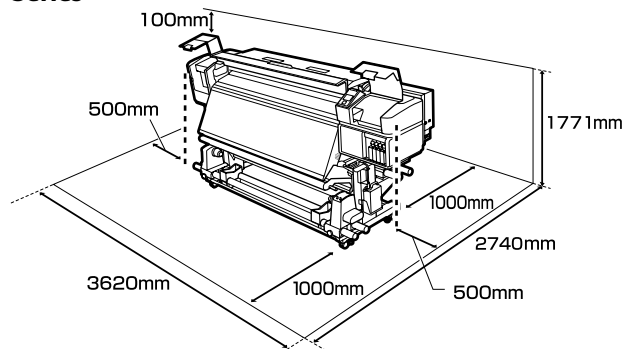

#### SC-S80600L Series/SC-S60600L Series

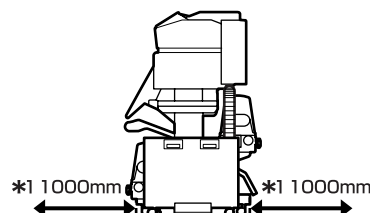
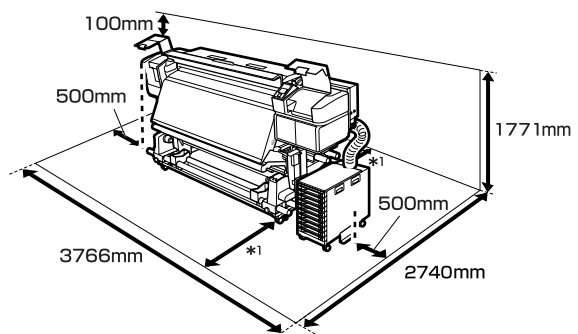

## Introduction

### Notes when using the printer

Note the following points when using this printer to avoid breakdowns, malfunctions, and print quality decline.

When using WH/MS ink, observe the following points as well.

 [“Notes on Usage of WH/MS Ink \(SC-S80600 Series/SC-S80600L Series\)” on page 23](#)

- ❑ When using the printer, observe the operating temperature and humidity range described in the "Specifications Table".  [“Specifications Table” on page 139](#)

Note, however, that the desired results may not be achieved if the temperature and humidity are within the limits for the printer but not within those for the media. Be sure the operating conditions suit the media. For more information, see the documentation supplied with the media.

Also, when operating in dry areas, air conditioned environment, or under direct sunlight, maintain the appropriate humidity.

- ❑ Avoid using the printer in locations with heat sources or that are exposed to direct draughts from ventilators or air conditioners. The print head nozzles could dry out and clog.
- ❑ Do not bend or tug the waste ink tube. Ink could spill inside or around the printer.
- ❑ Maintenance such as cleaning and replacement must be performed according to usage frequency or at recommended intervals. Failure to perform regular maintenance could result in loss of print quality. In the absence of the appropriate maintenance, continued use could damage the print head.  
 [“Cleaning Locations and Cleaning Timing” on page 60](#)

- ❑ The print head may not be capped (the print head may not return to the right side) if the printer is turned off when the media is jammed or an error has occurred. Capping is a function for automatically covering the print head with a cap (lid) to prevent the print head from drying out. In this case, turn on the power and wait a while until capping is performed automatically.



- ❑ When the power is on, do not remove the power plug or cut the power at the breaker. The print head may not be capped properly. In this case, turn on the power and wait a while until capping is performed automatically.
- ❑ The print head is automatically cleaned at a fixed interval after printing to keep the nozzle from clogging.  
Be sure that the Waste Ink Bottle is placed whenever the printer is on.
- ❑ As well as being expended during printing, ink is used during head cleaning and other maintenance required to keep the print head in working order.

### Notes when not using the printer

If you are not using it, note the following points when storing the printer. If it is not stored correctly, you may not be able to print properly the next time it is used.

When using WH/MS ink, observe the following points as well.

 [“Notes on Usage of WH/MS Ink \(SC-S80600 Series/SC-S80600L Series\)” on page 23](#)

- ❑ If the printer will not be used for an extended period (and switched off), use the cleaning cartridges/cleaning ink supply units (sold separately) and perform Pre-Storage Maint. Leaving the heads unwashed causes permanent clogs.  
See the following for more information.  
 [“Long-term Storage \(Pre-storage Maintenance\)” on page 88](#)
- ❑ If you do not print for a long time and do not perform pre-storage maintenance, turn the printer on at least once every seven days.  
If you do not print for a long time, the print head nozzles may become clogged. Head cleaning will be performed automatically after the printer is turned on and started. Head cleaning prevents clogged print heads and maintains print quality. Do not turn the printer off until cleaning is complete.
- ❑ If you have not used the printer for a long time, check the print head for clogging before you start printing. Perform head cleaning if the print head is clogged.  
 [“Printing nozzle check patterns” on page 86](#)

## Introduction

- ❑ The pressure rollers may crease media left in the printer. The media may also become wavy or curled, causing jams or resulting in the media coming into contact with the print head. Remove the media before putting the printer in storage.
- ❑ Store the printer after confirming that the print head has been capped (the print head is positioned at the far right). If the print head is left uncapped for a long time, the print quality may decline.

**Note:**

*If the print head is not capped, turn the printer on, and then turn it off.*

- ❑ Close all covers before placing the printer in storage. If you are not using the printer for a long time, put an anti-static cloth or cover on the printer to prevent dust. The print head nozzles are very small, and they can become clogged easily if fine dust gets on the print head, and you may not be able to print properly.
- ❑ When storing the printer, be sure that it is level: do not store it on an angle, on end, or upside down.

## Notes on handling ink cartridges/ink supply units

Note the following points when handling ink cartridges/ink supply units to maintain good print quality.



When using WH/MS ink, observe the following points as well.

 [“Notes on Usage of WH/MS Ink \(SC-S80600 Series/SC-S80600L Series\)” on page 23](#)

- ❑ Extra ink is required to fully charge the print head nozzles the first time the printer is used; replacement ink cartridges/ink supply units will be needed earlier than usual.
- ❑ Store ink cartridges/ink supply units at room temperature in a location that is not exposed to direct sunlight.
- ❑ To ensure print quality, use all the ink before the earlier of the following dates:
  - ❑ The expiry date shown on the ink cartridge/ink supply unit packaging

- ❑ 6 months from the day the ink cartridge packaging is opened, or 6 months from the day the ink supply unit is inserted in the tray
- ❑ If you move ink cartridges/ink supply units from a cold place to a warm place, leave them at room temperature for more than 4 hours before using them.
- ❑ Do not touch the ink cartridge/ink supply unit IC chip. You may not be able to print properly.
- ❑ You cannot print if any of the ink cartridge slots or ink supply unit trays are empty.
- ❑ Do not leave the printer without ink cartridges or trays installed. The ink in the printer will dry out and the printer will not function as expected. Leave ink cartridges/ink supply units inserted, even when the printer is not in use.
- ❑ Because the IC chip manages the cartridge's/ink supply unit's own information, such as the remaining ink level, you can still re-insert and use the ink cartridges/ink supply units if you removed them before the replacement message appears.
- ❑ Before you store ink cartridges/ink supply units that you remove during use, use a cleaning stick from the supplied Maintenance Kit to adsorb the ink stuck on their ink supply ports. Dried ink on the supply port may cause ink leaks when the ink cartridge/ink supply unit is reinserted and used. See the following for more information on cleaning methods.
  -  [“Long-term Storage \(Pre-storage Maintenance\)” on page 88](#)
 While ink cartridges/ink supply units are in storage, keep the ink supply ports free of dust. The ink supply port has a valve in it so it does not need to be capped.
- ❑ Removed ink cartridges/ink supply units may have ink around their ink supply ports, so be careful not to get any ink on the surrounding area.
- ❑ To maintain the quality of the print head, this printer is designed to stop printing before ink is completely expended, leaving ink in the used ink cartridges/ink supply units.
- ❑ Although the ink cartridges/ink supply units may contain recycled materials, it does not affect the printer's function or performance.

## Introduction

- ❑ Do not dismantle or remodel ink cartridges/ink supply units. You may not be able to print properly.
- ❑ Do not drop or knock the ink cartridges/ink supply units against hard objects; otherwise ink may leak from them.
- ❑ Ink cartridges/ink supply units loaded in the printer or the ink unit (except for WH and MS) must be removed and thoroughly shaken once every 3 weeks.  
WH and MS must be removed and thoroughly shaken every day before starting printing work. You do not need to shake the cleaning cartridge/cleaning ink supply unit.  
Shaking Ink Cartridges  "Shaking" on page 71  
Shaking Ink Supply Units  "Shaking" on page 74

---

### Notes on Handling the Ink Unit (SC-S80600L Series/SC-S60600L Series)

- ❑ Use screws and fixing wire to fasten the fixing wire to the front and back of the printer's legs. The ink tube may break if you move the ink unit while it is connected to the printer without being fastened with the fixing wire.
- ❑ Do not remove the ink tube connector after it is connected in setup. Ink may leak if you remove this without paying close attention.

---

### Handling Media

Note the following when handling or storing media. Media that are in poor condition will not produce good quality prints.

Be sure to read the documentation provided with each type of media.

#### Notes on Handling

- ❑ Do not fold the media or damage the printable surface.
- ❑ Do not touch the printable surface. Moisture and oils from your hands can affect print quality.

- ❑ When handling media, hold it by both edges. We recommend wearing cotton gloves.
- ❑ Keep the media dry.
- ❑ Packaging materials can be used to store media and should not be thrown away.
- ❑ Avoid locations that are subject to direct sunlight, excessive heat, or humidity.
- ❑ When not in use, media should be removed from the printer, rewound, and inserted in its original packaging for storage. Leaving media in the printer for extended periods may cause it to deteriorate.

### Handling Media After Printing

To maintain long lasting, high quality print results, note the following points.

- ❑ Do not rub or scratch the printed surface. If they are rubbed or scratched, the ink may peel off.
- ❑ Do not touch the printed surface, as this may remove the ink.
- ❑ Make sure printouts are completely dry before folding or stacking, otherwise discoloration or other marks may appear where the prints touch. These marks will disappear if the prints are immediately separated and dried but will become permanent if the surfaces are not separated.
- ❑ Avoid direct sunlight.
- ❑ To prevent discoloration, display and store prints as instructed in the documentation supplied with the media.

### Notes on Usage of WH/MS Ink (SC-S80600 Series/SC-S80600L Series)

WH/MS inks may sediment (components settling to the bottom of the liquid) easier than other inks due to ink characteristics. Sedimentation triggers tint unevenness in printing results or clogged nozzles.

Before using WH/MS inks, take note of the following cautions.

## Introduction

### Notes on auto ink circulation

This function automatically circulates inks in the print head or tubes for WH/MS inks at periodic intervals to prevent ink sedimentation from occurring.

Note the following points to use the auto ink circulation function correctly.

- ❑ We recommend always leaving the printer on. Since auto ink circulation is not performed at the appropriate times when the power is turned off, sedimentation that cannot be dissolved may occur which can cause problems in the printer. When not using the printer for a long period of time, see: [☞ “Long-term Storage \(Pre-storage Maintenance\)” on page 88](#)
- ❑ When printing multiple copies as a batch, auto ink circulation may be performed between pages. In this situation, colors may differ before and after circulation, and it may take some time to finish the print job. We recommend completing **Ink Circulation** manually before you start printing to avoid pauses due to automatic ink circulation. [☞ “The Maintenance Menu” on page 111](#)
- ❑ To cancel auto ink circulation, press the **II** button while **Circulating ink...** is being displayed on the control panel screen. However, if you print using WH/MS after canceling, tint unevenness may occur in printing results. Furthermore, it cannot be canceled while ink circulation is required.

### Shake once every 24 hours

After ink cartridges/ink supply units are inserted, they must be removed and thoroughly shaken once every 24 hours.

Shaking ink cartridges [☞ “Shaking” on page 71](#)

### Notes on Storing Ink Cartridges/Ink Supply Units

Cartridges must be stored flat (that is, laid horizontally on their sides).

If the cartridges are stored vertically, even shaking the cartridges before use may fail to dissolve the materials that have sedimented in the ink during storage.

### When tint unevenness is detected in printing results

Perform **Ink Refresh** on the control panel menu.

[☞ “The Maintenance Menu” on page 111](#)



## Introduction

# Introducing the Supplied Software

The following 2 types of CDs are included with this printer.

- ❑ Software disc  
See the following table for descriptions of the software that has been supplied.
- ❑ Epson Edge Print disc  
Epson Edge Print is a software RIP that can be effortlessly used with easy-to-understand operations. See the *Setup Guide* (booklet) for how to install the software. See the online help for details about functions.

## Supplied software

The following table shows the software supplied.



Windows versions are provided on the software disc supplied. If you are using a Mac or a computer without a disc-drive, you can download and install the software from the following link: <https://epson.sn>.

For information about the software, see the on-line help for the application or the *Network Guide* (Online Manual).

**Note:**

*Printer drivers are not provided. A software RIP is required for printing. The Epson Software RIP, "Epson Edge Print", is included with this printer on a separate CD.*

*The Epson Web site provides supported plug-in software for the printer.*

Software Name	Summary
Epson Edge Dashboard	<p>After installation, it operates as resident software. Hands off or updates the print settings file (EMX) in Epson Edge Print, and sends notifications on the status of registered printers. You can also perform the following control operations for supported Epson printers.</p> <ul style="list-style-type: none"> <li>❑ You can easily acquire the following variety of information provided by Epson on the internet. <ul style="list-style-type: none"> <li>❑ Print settings files (EMX)</li> <li>❑ Update information for the printer firmware (you can update the firmware easily from Epson Edge Dashboard)</li> <li>❑ Update information for software and manuals installed from the supplied software disc and Epson Setup Navi (When you receive an update information, you can quickly update the software by starting EPSON Software Updater.)</li> <li>❑ Information from Epson</li> </ul> </li> <li>❑ You can monitor the status of the printer connected to a computer with Epson Edge Dashboard installed over a network or USB connection.</li> <li>❑ You can easily make and change media settings from a computer and write to the printer.</li> </ul> <p> <a href="#">"Starting Procedure" on page 27</a></p> <p> <a href="#">"Closing Procedure" on page 27</a></p>
EPSON Software Updater	<p>The software checks if new software or update information is available on the Internet and installs it. You can also update the manuals, Epson Edge Dashboard, and Epson Edge Print for this printer.</p>

## Introduction

Software Name	Summary
Epson communications drivers (Windows only)	Epson communications drivers is required when using Epson Edge Dashboard, Epson Edge Print and when connecting a computer to the printer via USB. Make sure these are installed.
EpsonNet Config SE	With this software, you can configure various network settings for the printer from your computer. This is useful as it allows you to enter addresses and names using the keyboard.

---

## Pre-installed software

This software is pre-installed on the printer. You can start it from a web browser via a network.

Software Name/ Function	Function
Remote Manager	You can make network settings from Remote Manager. It also provides an e-mail notification function to inform you when errors and so on occur in the printer.  <a href="#">"Using Remote Manager" on page 28</a>

## Introduction

## Using Epson Edge Dashboard

### Starting Procedure

Epson Edge Dashboard is a Web application.

- 1 The application can be launched using either of the following two methods.

#### Windows

- ❑ Click the **Epson Edge Dashboard** icon on the Desktop toolbar and select **Show Epson Edge Dashboard**.

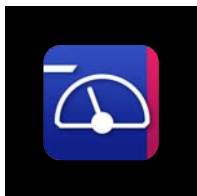

- ❑ Click **Start > All Programs (or Programs) > Epson Software > Epson Edge Dashboard > Epson Edge Dashboard**.

#### Mac

- ❑ Click the **Epson Edge Dashboard** icon on the menu bar of the Desktop and select **Show Epson Edge Dashboard**.



- 2 Epson Edge Dashboard starts.

For details, see the Epson Edge Dashboard help.

### Closing Procedure

Close the Web browser. However, since Epson Edge Dashboard is a resident software, it does not stop running.

## Using EPSON Software Updater

### Checking software update availability

- 1 Check the following status.
  - ❑ The computer is connected to the Internet.
  - ❑ The printer and the computer can communicate.

- 2 Start EPSON Software Updater.

#### Windows 8.1/Windows 8

Enter the software name in the search charm, and select the icon displayed.

#### Except for Windows 8.1/Windows 8

Click **Start > All Programs (or Programs) > Epson Software > EPSON Software Updater**.

#### Mac OS X

Click **Go - Applications - Epson Software - EPSON Software Updater**.

#### Note:

*In Windows, you can also start by clicking the printer icon on the desktop toolbar and selecting **Software Update**.*

- 3 Update the software and manuals.  
Follow the on-screen instructions to continue.

#### **!** Important:

*Do not turn off the computer or printer while updating.*

#### Note:

*Software that is not displayed in the list cannot be updated using EPSON Software Updater. Check for the latest versions of the software from the Epson Web site.*

<https://www.epson.com>

## Introduction

### Receiving update notifications

- 1 Start EPSON Software Updater.
- 2 Click **Auto update settings**.
- 3 Select an interval for checking for updates on the printer's **Interval to Check** box, and then click **OK**.

### Using Remote Manager

Provides an overview of starting the software and the functions provided.

### Starting Procedure

Start the software on a computer that is connected to the same network as the printer.

- 1 Check the printer's IP address.  
Confirm that the printer is ready to print. Press the **Menu** button, and then select, in order, **Other Settings - Network Setup - IP Address Setting**.
- 2 Start a Web browser on the computer that is connected to the printer over the network.
- 3 Enter the printer's IP address in the address bar of the Web browser, and then press the **Enter** key or the **Return** key.  
Format: https://printer's IP address/  
Example: https://192.168.100.201/

### Closing Procedure

Close the Web browser.

### Uninstalling Software



#### **Important:**

- Log into a "Computer administrator" account (an account with administrative privileges).
- Enter the administrator password when prompted and then proceed with the remainder of the operation.
- Exit any other applications that may be running.

#### **Windows**

This section describes how to uninstall Epson Edge Dashboard and the Epson communications drivers using them as an example.

- 1 Turn off the printer, and disconnect the cable from the computer.
- 2 On the computer on which the software is installed, click **Control Panel**, and then click **Uninstall a program** from the **Programs** category.
- 3 Select the software you want to remove and then click **Uninstall/Change** (or **Change/Remove**).  
Selecting the following deletes the Epson communications drivers. The model number appears in XXXXX.  
 EPSON SC-SXXXXX Series Comm Driver Printer Uninstall  
  
To uninstall **Epson Edge Dashboard**, select Epson Edge Dashboard.
- 4 Select the target printer icon, and then click **OK**.
- 5 Follow the on-screen instructions to continue.  
When the delete confirmation message appears, click **Yes**.

If you are reinstalling the Epson communications drivers, restart the computer.

## Introduction

### Mac

The following describes how to remove Epson Edge Dashboard.

- 1 Quit **Epson Edge Dashboard**.
- 2 Double-click **Applications - Epson Software - Epson Edge Dashboard - Epson Edge Dashboard Uninstaller**.

Follow the on-screen instructions to continue.

## Basic Operations

## Basic Operations

### Notes on loading media

If the following points are not observed when handling media, small amounts of dust and lint may stick to the media surface and cause ink drops in the print results.

**Do not place exposed media directly on the floor.**

Media should be rewound and inserted in its original packaging for storage.

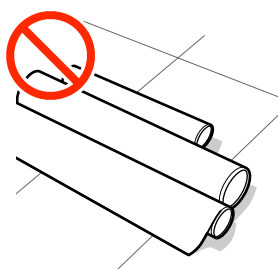

**Do not carry media with the media surface pressed against clothing.**

Handle media in its individual packaging until just before loading the media in the printer.

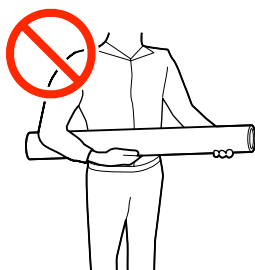

### Notes on Loading Media

**⚠ Caution:**

- ❑ *The heaters and media edge plate may be hot; observe all necessary precautions. Failure to observe the necessary precautions could result in burns.*
- ❑ *Because the media is heavy, it should not be carried by one person.*
- ❑ *Be careful not to trap your hands or fingers when opening or closing the front cover. Failure to observe this precaution could result in injury.*
- ❑ *Do not rub your hands along the edges of the media. The edges of the media are sharp and can cause injury.*

**Load the media just before printing.**

The pressure rollers may crease media left in the printer. The media may also become wavy or curled, causing jams or resulting in the media coming into contact with the print head.

**Do not load media if the right and left edges are uneven.**

If media is loaded and the right and left edges of the roll are uneven, media feeding problems may cause the media to move around during printing. Either rewind to align the edges or use a roll without any issues.

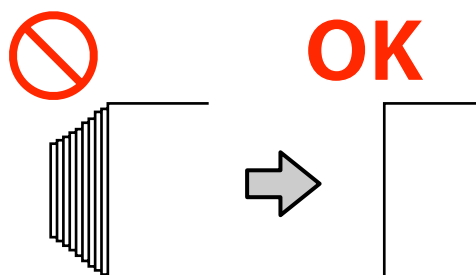

### Loading media

You can check the procedure in a video on YouTube.

[Epson Video Manuals](#)

**Basic Operations**

- 1 Press the  button, and then wait until **Load media.** is displayed on the screen.

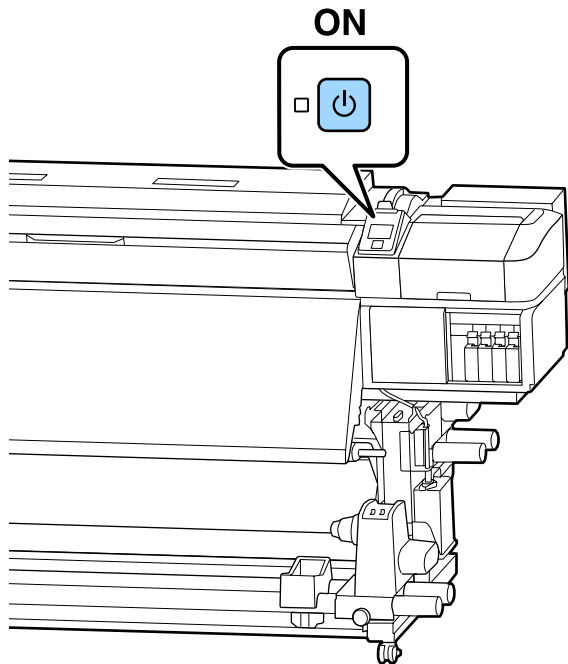

- 2 Open the front cover, and then lower the media loading lever.

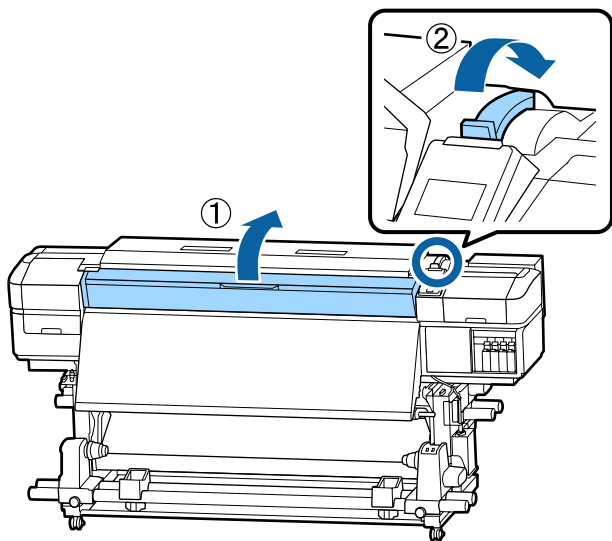

- 3 While holding the tabs of the media edge plate on both sides, move the plate out of the way toward both edges of the platen.

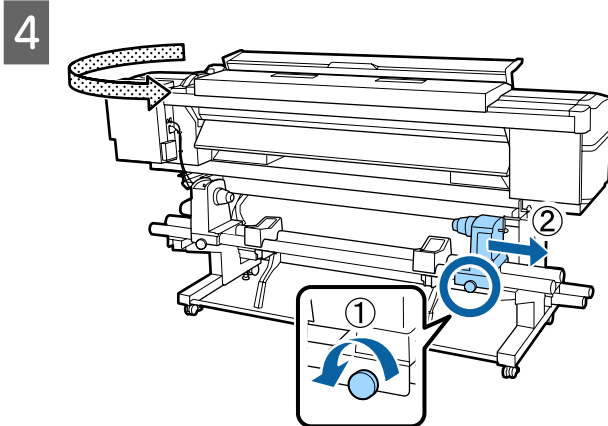
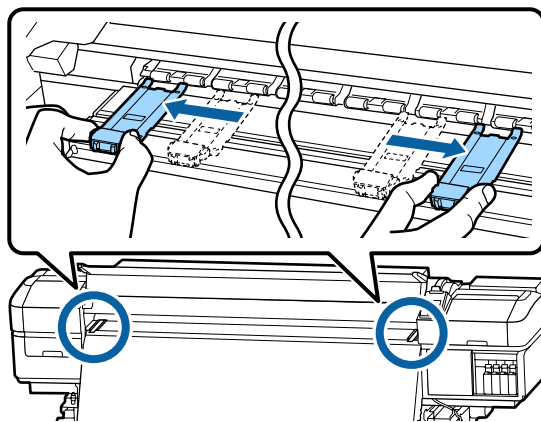

**! Important:**

If the right holder handle shaft is not visible, rotate the handle forward until it stops. The media can not be properly loaded if the handle shaft is not visible.

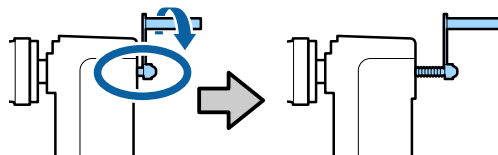

**Basic Operations**

**5** Move the roll holder to the set position according to the roll size of the media that will be loaded.

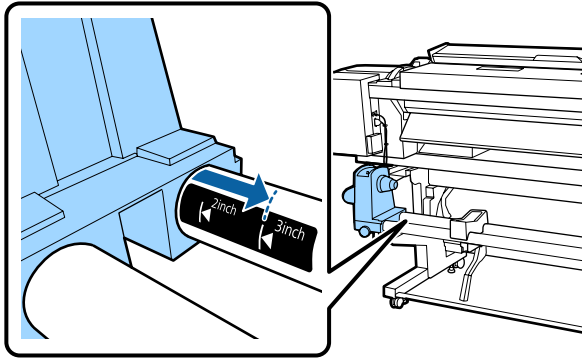

**6** Tighten the screw until the screw no longer turns.

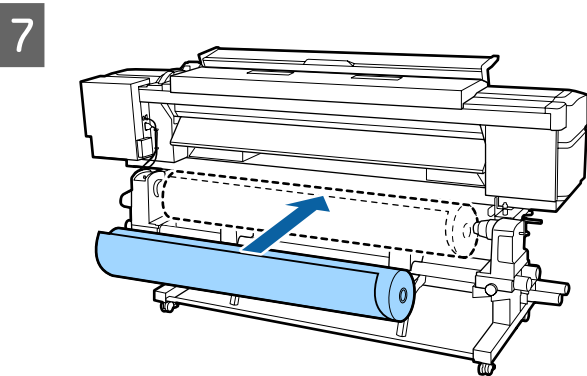
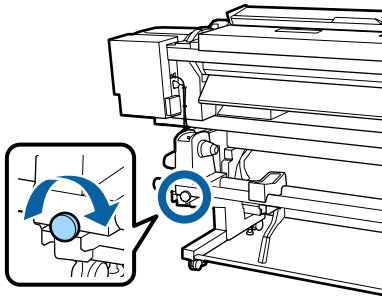

**Note:**  
The method of placing the roll media varies as follows depending on how media is rolled.

**Printable Side Out**

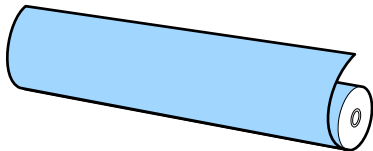

**Printable Side In**

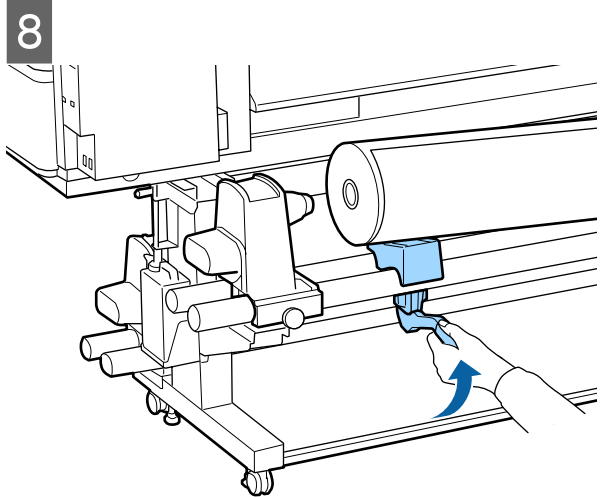
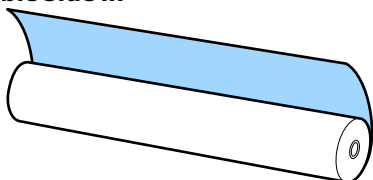

**9** Firmly insert the roll core of the media onto the roll holder.

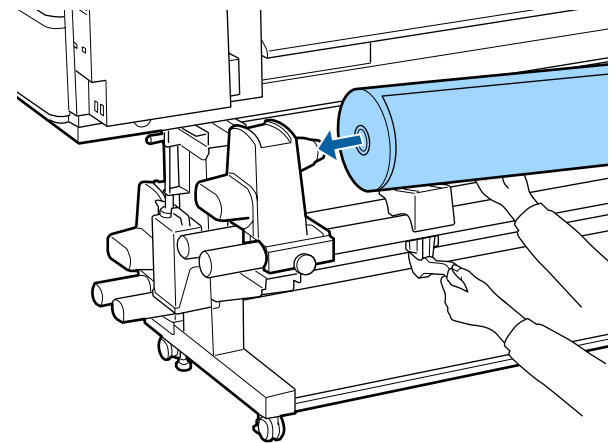

**Note:**  
If the roll of media has an outer diameter which is less than 140 mm, the roll core will not reach the holder when raised using the lift lever.

Raise it with your hands, and insert the roll core onto the roll holder.



### Basic Operations

10

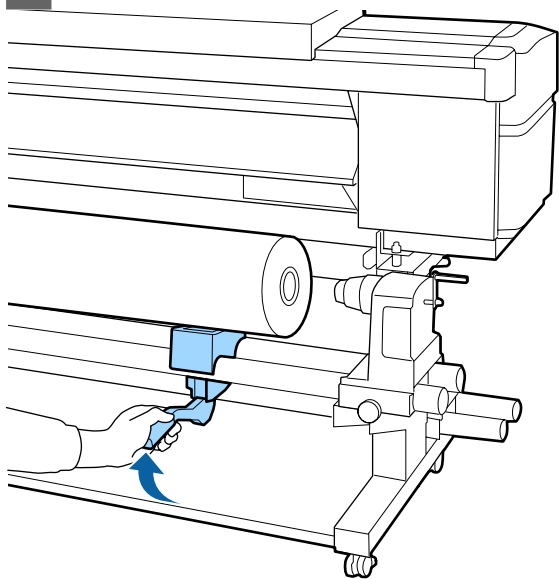

11

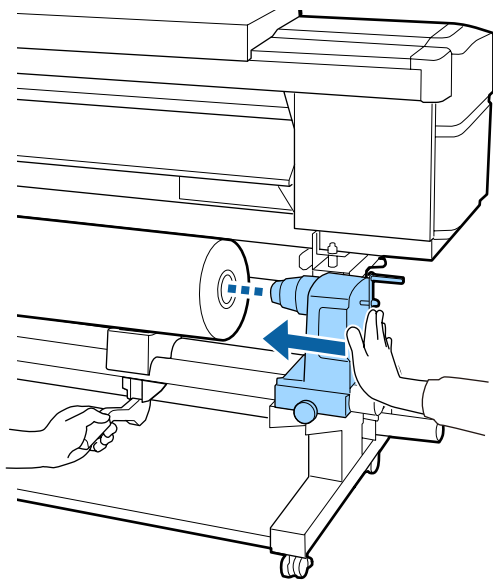

**Note:**

If the roll of media has an outer diameter which is less than 140 mm, the roll core will not reach the holder when raised using the lift lever.

Raise it with your hands, and insert the roll core onto the roll holder.

12

To ensure the roll holder is inserted into the roll core sufficiently, push it twice.

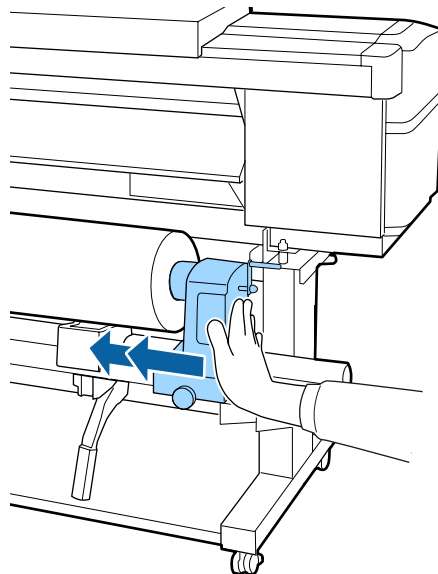

**! Important:**

If the roll holder is inserted into the roll core insufficiently, media is not fed correctly during printing because of slippage between the roll holder and roll core.

This may cause banding in the print results.

13

Tighten the screw until the screw no longer turns.

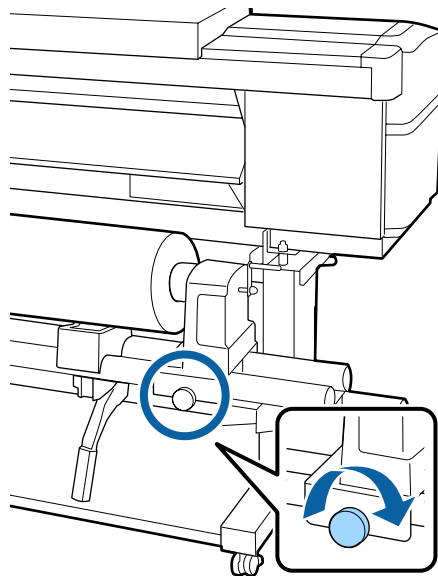

### Basic Operations

**! Important:**

- ❑ If the roll holder screw is loose, the roll holder may move during printing. This could cause stripes and unevenness in the print results.
- ❑ If the right and left edges of the roll are not aligned, realign them.

**14** Rotate the handle until part A in the illustration below is fully inserted.

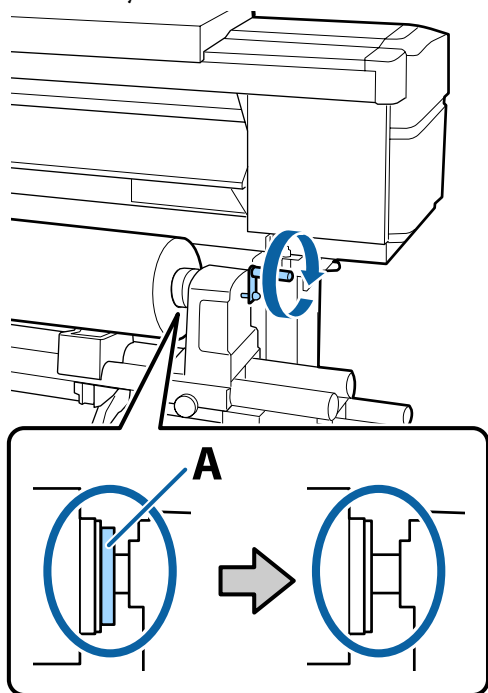

**! Important:**

Once part A is hidden, do not turn the handle any further. Failure to observe this precaution could damage the roll holder.

If part A is still visible even after the handle has been turned fully, rewind the handle. Loosen the roll holder screw on the right side, and then restart from Step 4.

**15** Insert the media approximately 30 cm into the opening, then lower the media loading lever.

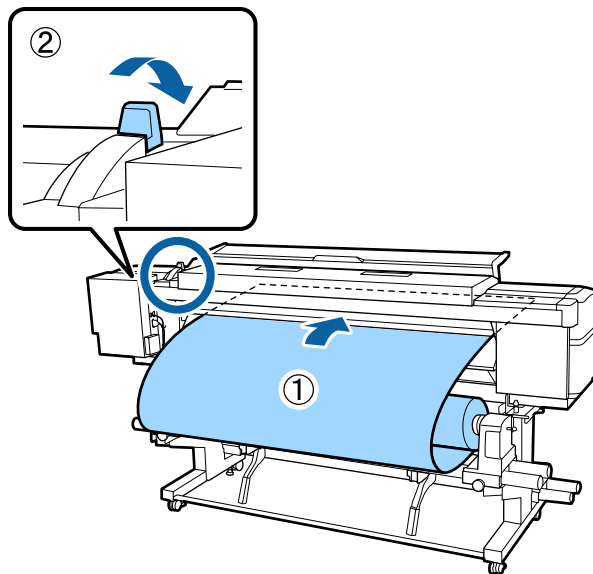

**16** Confirm that the left edge of the media is within the range of the label's rectangle, as shown in the illustration below.

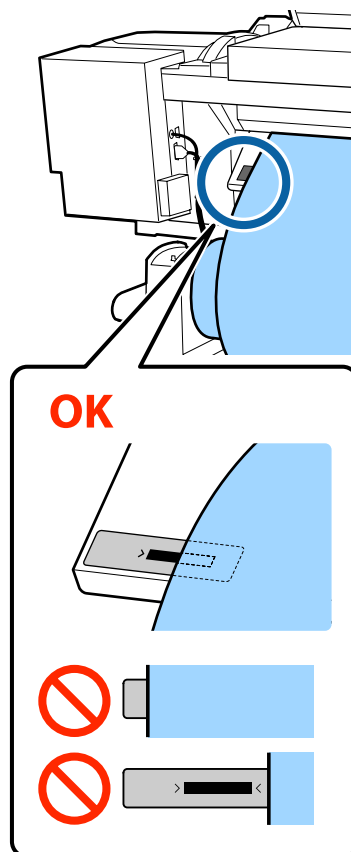

**Basic Operations**

**Note:**  
 If the left edge of the media is not within the black square of the label, do steps 5 to 16 in reverse to adjust the position of the roll holder. Do not attempt to reposition the roll holders while they are inserted in the media.

**17**

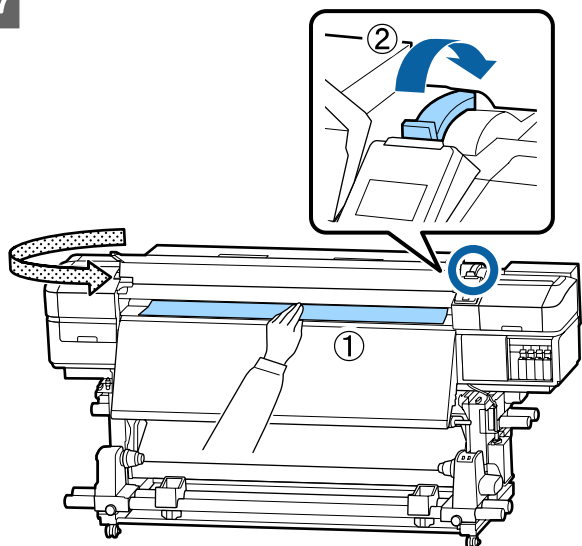

**18**

Hold the center of the media in one hand, and pull it straight until it is aligned with the bottom edge of the label on the after heater.

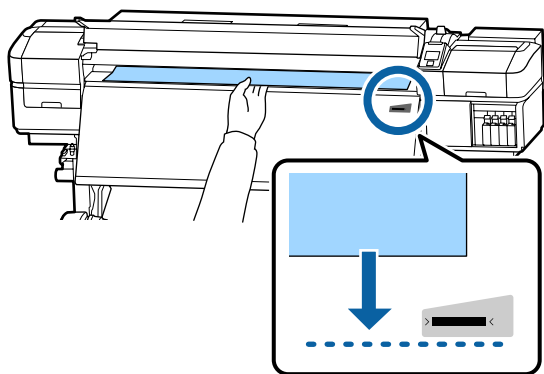

Do not pull the media with both hands. This could cause the media to skew or move around.

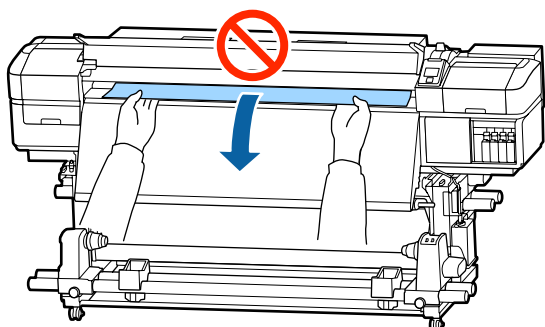

**19**

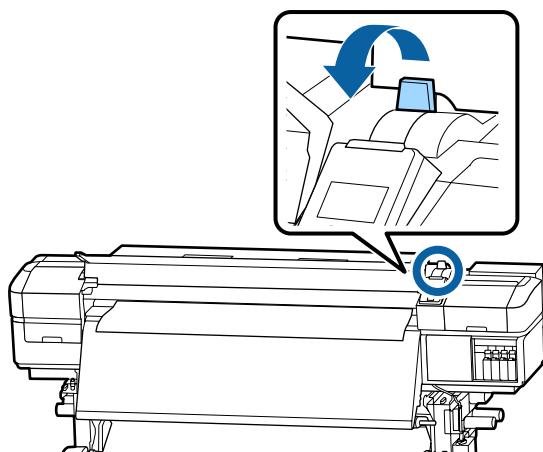

**20**

Tap lightly on both ends of the media, and check if there is a difference in tension between the left and right sides.

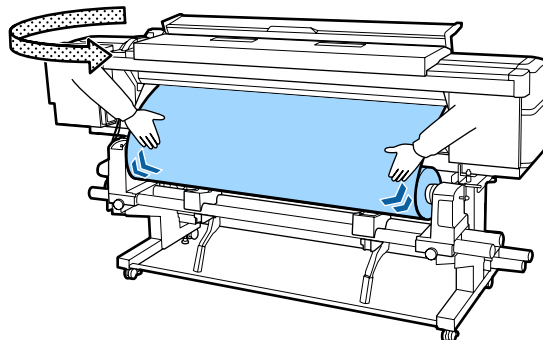

If there is a difference in tension, the media becomes loose.

From the front of the printer, raise the media loading lever, and correct the looseness in the media.

Once the looseness is corrected, lower the media loading lever.

## Basic Operations

- 21** While holding the tabs of the media edge plate on both sides, move the plate to the top edge of the media.  
Adjust so that the edges of the media are aligned with the center of the round holes in the media edge plates.

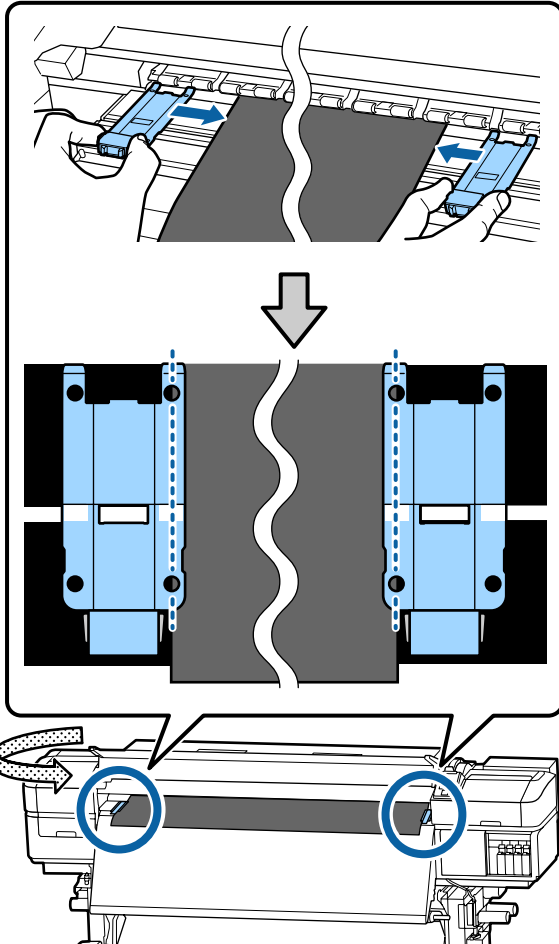

**!** **Important:**

- ❑ Do not use the media edge plates with media that is 0.4 mm or more thick. The media edge plates could touch and damage the print head.
- ❑ Always position the plates so that the edges of the media are at the centers of the round holes. Incorrect positioning causes banding (horizontal banding, tint unevenness, or stripes) during printing.
- ❑ Move the media edge plates to the left and right edges of the platen when they are not in use.
- ❑ Do not use the media edge plates if the sides of the printed media are smudged.

**22**

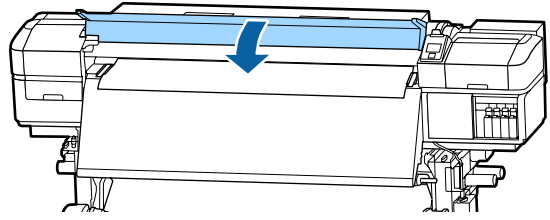

## Using the Auto Take-up Reel Unit

The Auto Take-up Reel Unit automatically takes up media as it is printed, improving the efficiency of unmanned operation.

The Auto Take-up Reel Unit for this printer can take up media in either of the following directions.

Printed side out

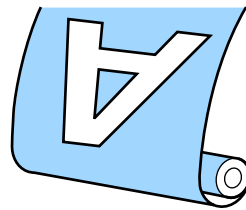

Printed side in

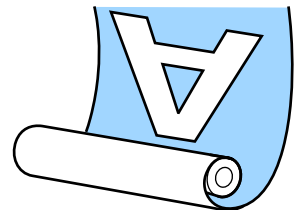

Taking-up with printed side out places the printed surface on the outside of the roll.

Taking-up with printed side in places the printed surface on the inside of the roll.

You can check the procedure in a video on YouTube.

[Epson Video Manuals](#)

## Basic Operations

### **Caution:**

- ❑ Follow the instructions in the manual when loading media or roll cores or removing media from the take-up roll. Dropping media, roll cores, or take-up rolls could result in injury.
- ❑ Be sure that your hands or hair do not get caught in the Media Feeding Unit or Auto Take-up Reel Unit while it is operating. Failure to observe this precaution could result in injury.

## Attaching the Roll Core

### Preparing

#### Use a roll core that is longer than the width of the media.

This allows the media to be taken up without protruding from the core.

#### Prepare the supplied paper tape.

We recommend this method for attaching media to the roll core due to the following advantages.

- ❑ It allows you to prevent misalignment of the roll at the left and the right edges, and to prevent the media from moving around, which provides a stable printing length for print jobs.
- ❑ Media is not wasted.
- ❑ Media can be easily removed from the roll core after winding.

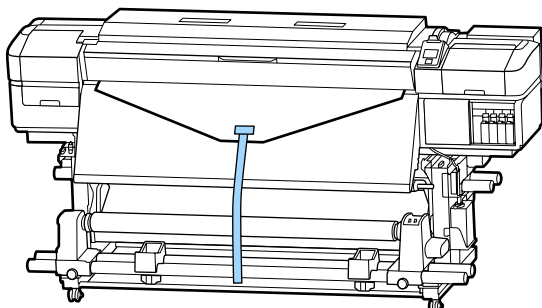

When the supplied paper tape runs out, purchase commercially available paper tape with a width of 20 to 25 mm (that is not easily stretched or cut). If you do not have any paper tape, cut media into pieces that are 20 to 25 mm wide and approximately 70 cm long.

## Loading

1

Keep the ▼ button pressed until the leading edge of the media reaches the center of the after heater.

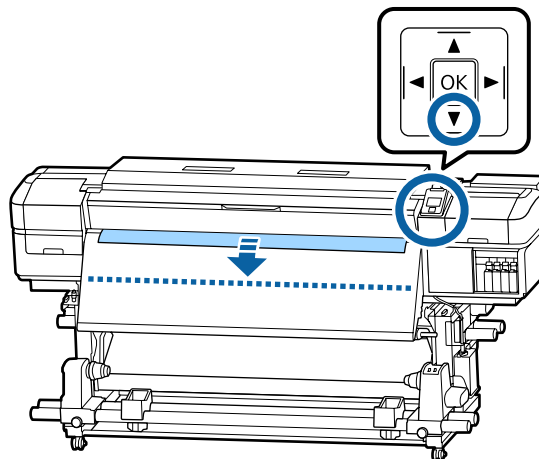

### **Important:**

Always press the ▼ button to feed the media. If the media is pulled by hand, the media may twist during take-up.

2

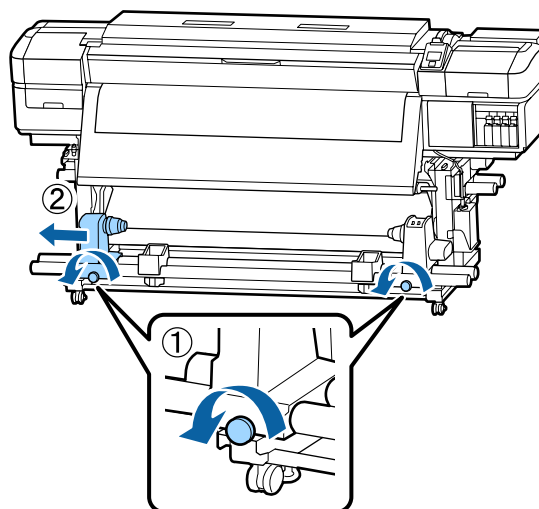

### Basic Operations

- 3** Align the roll core holder with the right edge of the media, and tighten the screw.

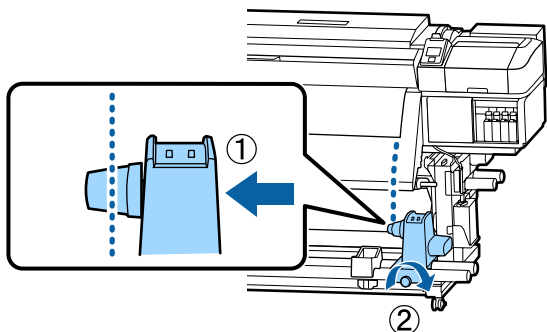

- 4** Insert the roll core onto the right holder.

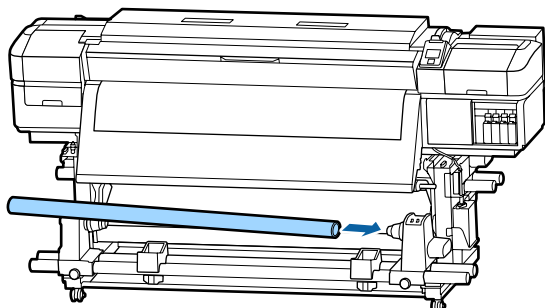

- 5** Push the holder until part A shown in the illustration below is fully inserted, and tighten the screw.

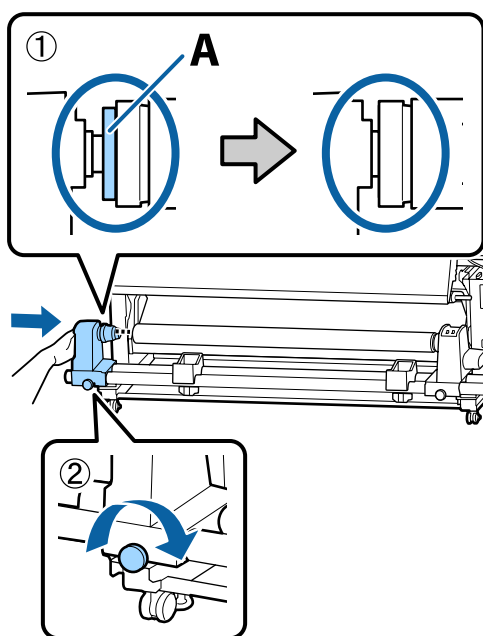

**!** **Important:**

Stop when part A is no longer visible. The take-up reel unit may not function as expected if the holder is inserted too far.

- 6** Leave a 10 to 20 cm wide section in the center of the media, and cut at least 25 cm in height from the left and right corners of the media.

Cutting the media prevents feeding problems, such as the left and right corners of media being folded and caught at the start of take-up.

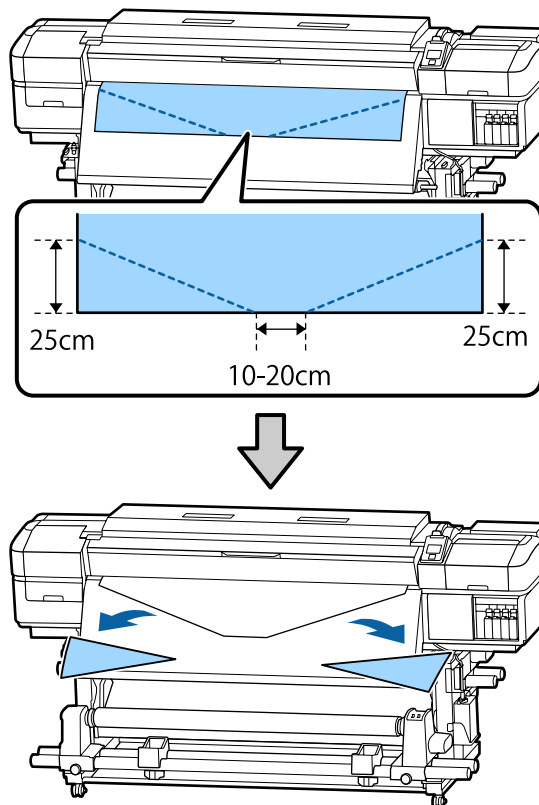

For the subsequent steps, see the following depending on how the media is rolled.

For information on taking-up with printed side out, see [“Take-up with the Printed Side Facing Out” on page 39.](#)

For information on taking-up with printed side in, see [“Take-up with the Printed Side Facing In” on page 41.](#)

**Basic Operations**

**Take-up with the Printed Side Facing Out**

- 1 Cut the paper tape approximately 70 cm in length, and paste it approximately in the center of the media using commercially available adhesive tape.

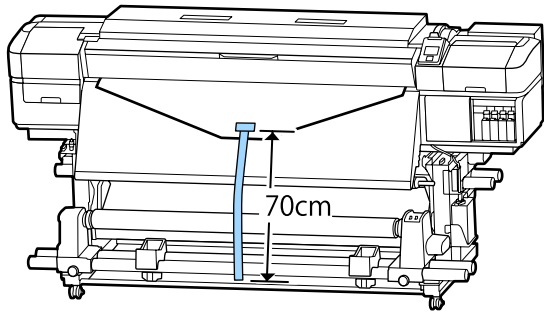

- 2 While pulling the paper tape straight down, wrap it around the roll core from front to back, and affix it using commercially available adhesive tape.

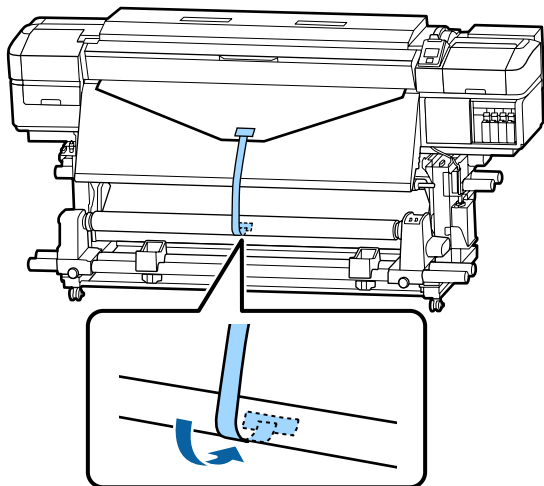

**! Important:**

Attach the media to the take up roll core with the media in a taut state. If media is attached in a loose state, the media may move around during take-up.

- 3 Flip the Auto switch to  .

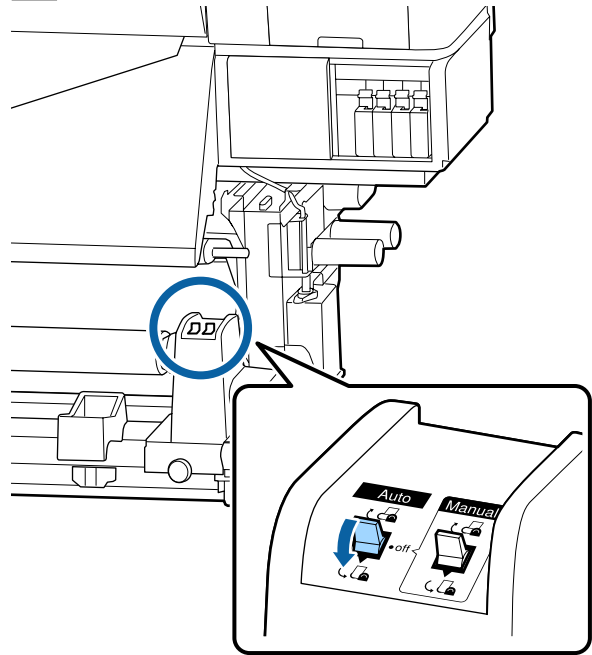

- 4 Lower the tension bar until it slightly touches the paper tape.

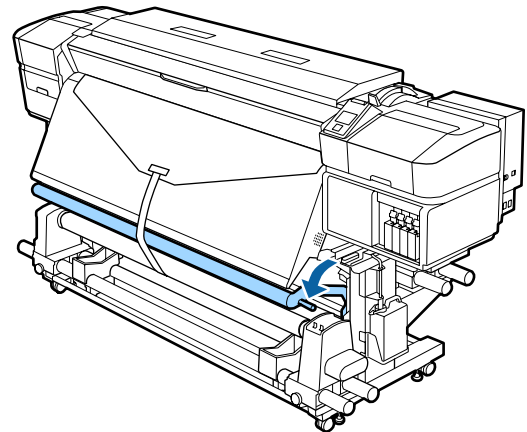

### Basic Operations

#### When there is no paper tape

- 1 While pulling the center section of the media straight down, affix the media to the take up roll core with commercially available adhesive tape.

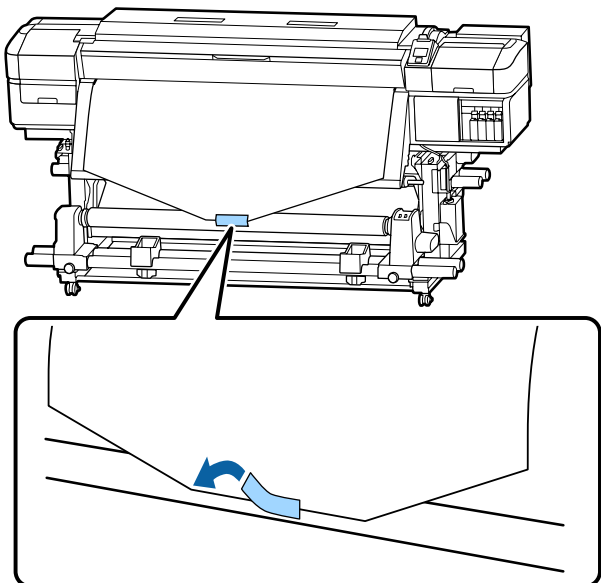

**! Important:**

Attach the media to the take up roll core with the media in a taut state. If media is attached in a loose state, the media may move around during take-up.

- 2 Press the ▼ button in the control panel to feed enough media for a single wrap around the roll core.

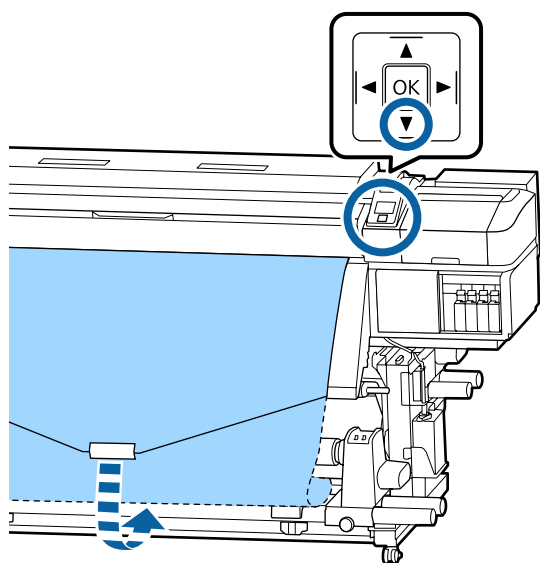

- 3 Flip the Auto switch to Off, and hold down the Manual switch to wrap the media once around the roll core.

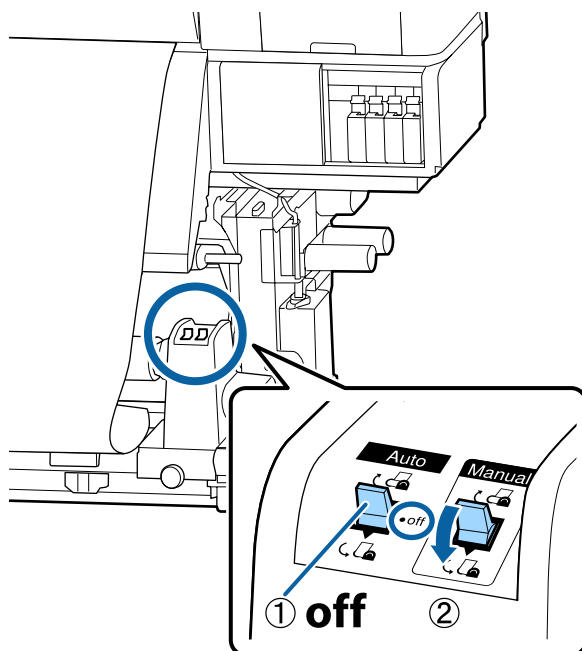

- 4 Flip the Auto switch to On.

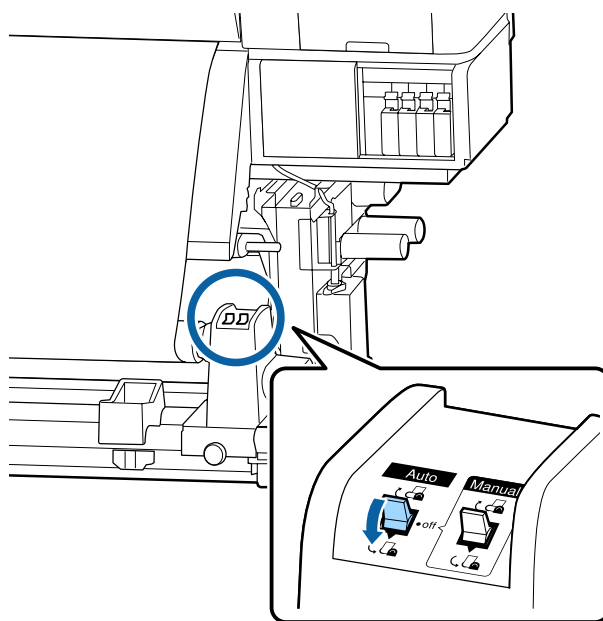



### Basic Operations

- 5** Lower the tension bar until it slightly touches the media.

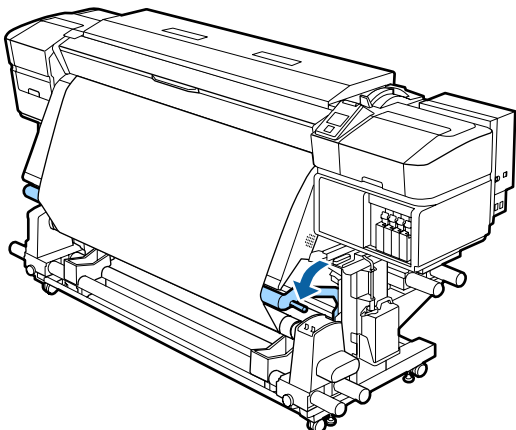

- 6** Confirm that the media is attached without looseness.

If the tension on the left and right of the media is different in the areas shown in the illustration below, the media will not be taken up correctly. When one side is loose, restart the procedure from Step 1.

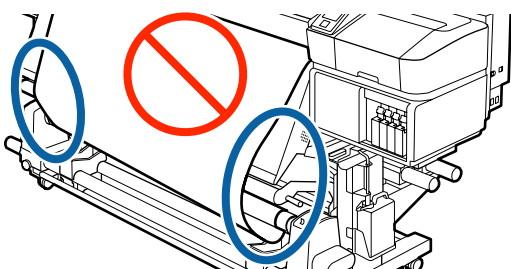

**Note:**

You can confirm differences in tension by lightly tapping both edges of the media as shown in the illustration below.

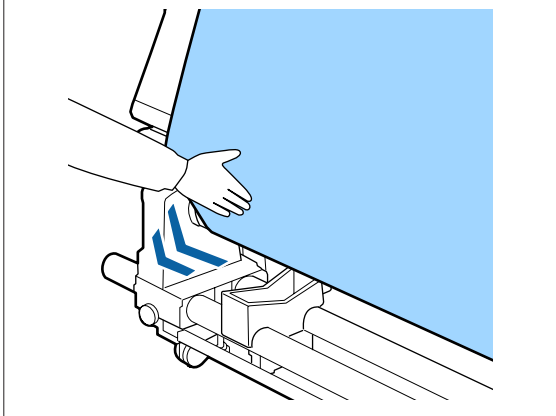

- 7** Continue holding down the ▼ button until the media has wrapped around once or twice.

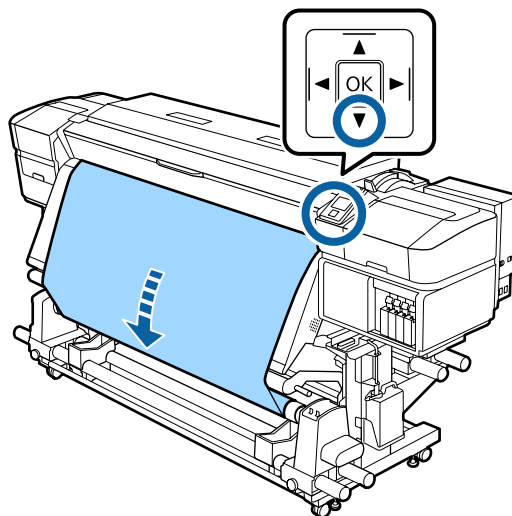

### Take-up with the Printed Side Facing In

- 1** Cut the paper tape approximately 70 cm in length, and paste it approximately in the center of the media using commercially available adhesive tape.

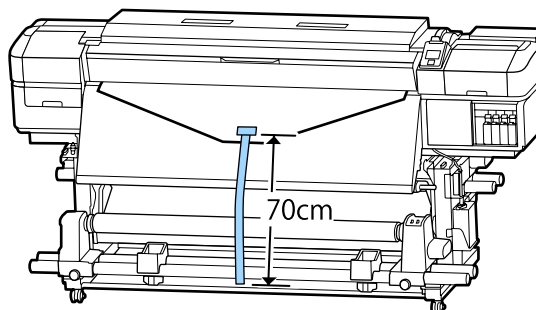

### Basic Operations

- 2** While pulling the paper tape straight down, wrap it around the roll core from back to front, and affix it using commercially available adhesive tape.

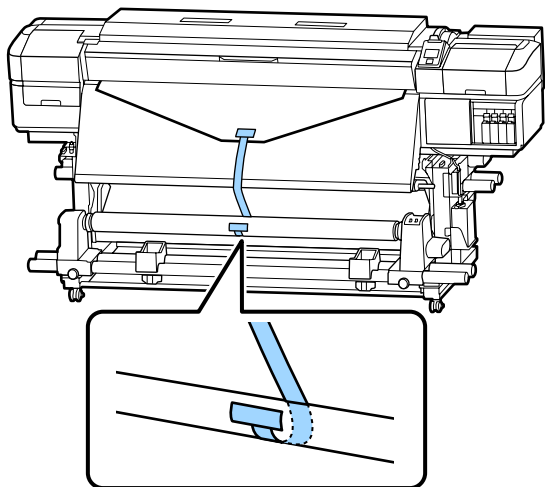

**!** **Important:**

Attach the media to the take up roll core with the media in a taut state. If media is attached in a loose state, the media may move around during take-up.

- 3** Flip the Auto switch to .

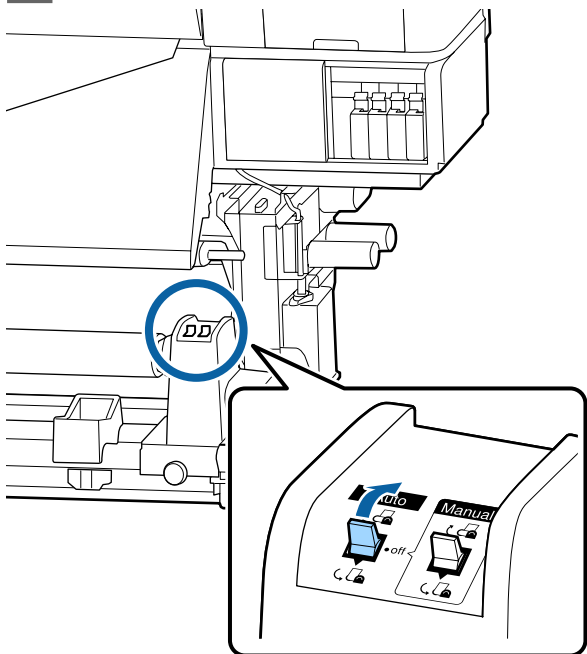

- 4** Lower the tension bar until it slightly touches the paper tape.

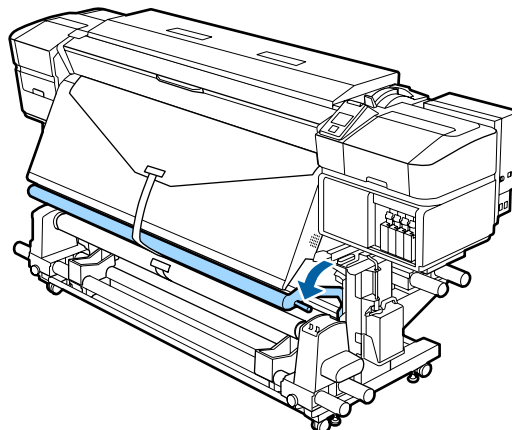

**When there is no paper tape**

- 1** While pulling the center of the media straight down, wrap it around the roll core from back to front, and affix it using commercially available adhesive tape.

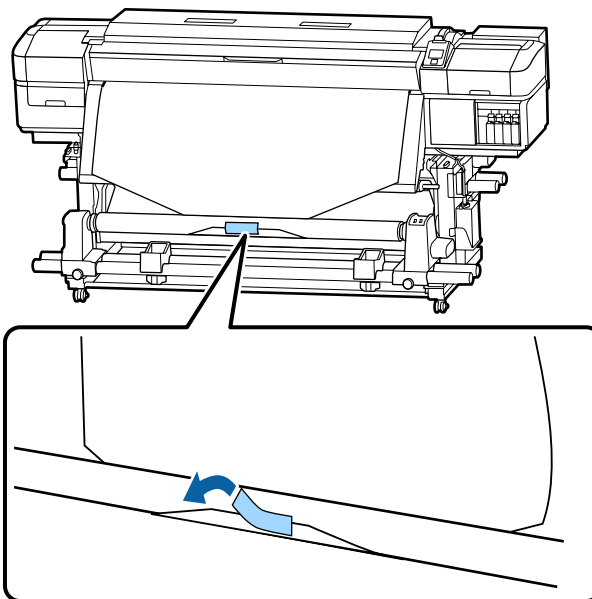

**!** **Important:**

Attach the media to the take up roll core with the media in a taut state. If media is attached in a loose state, the media may move around during take-up.

### Basic Operations

- 2** Press the ▼ button in the control panel to feed enough media for a single wrap around the roll core.

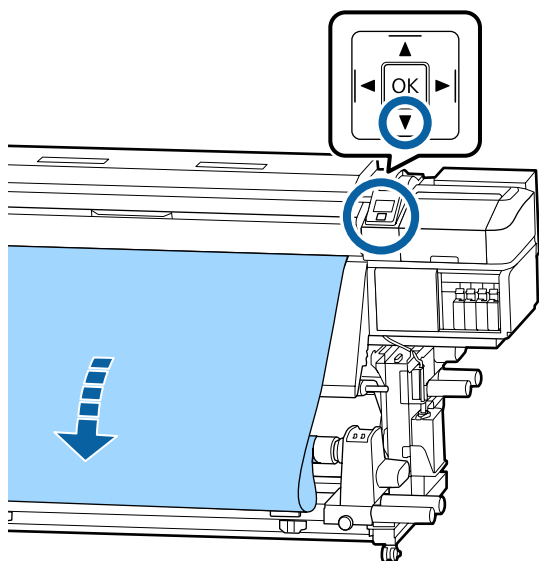

- 3** Flip the Auto switch to Off, and hold down the Manual switch to wrap the media once around the roll core.

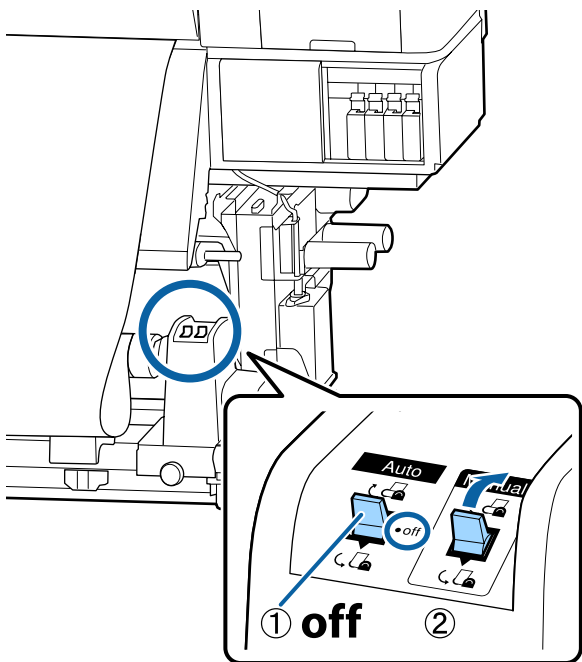

- 4** Flip the Auto switch to .

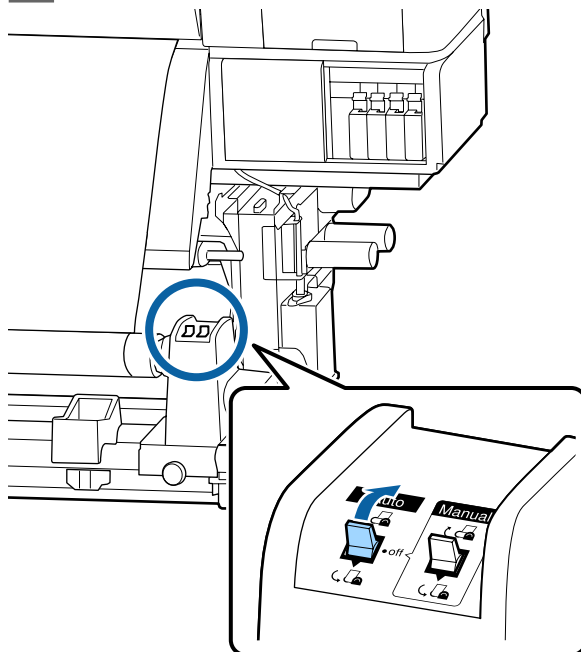

- 5** Lower the tension bar until it slightly touches the media.

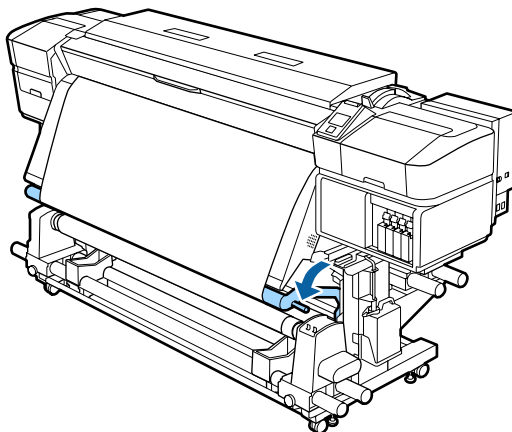

- 6** Confirm that the media is attached without looseness.

If the tension on the left and right of the media is different in the areas shown in the illustration below, the media will not be taken up correctly. When one side is loose, restart the procedure from Step 1.

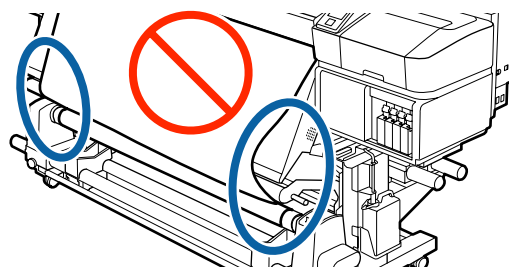

## Basic Operations

**Note:**

You can confirm differences in tension by lightly tapping both edges of the media as shown in the illustration below.

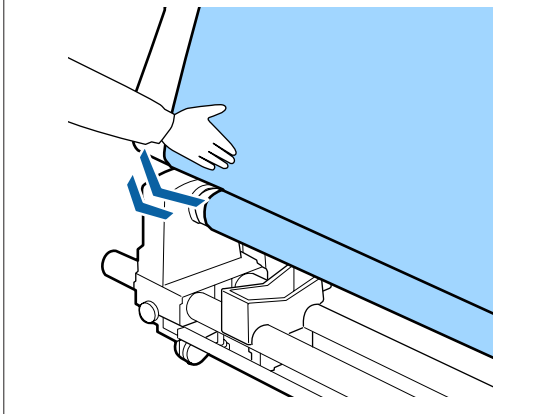

- 7 Continue holding down the ▼ button until both edges of the media reach the paper core and wrap around once or twice.

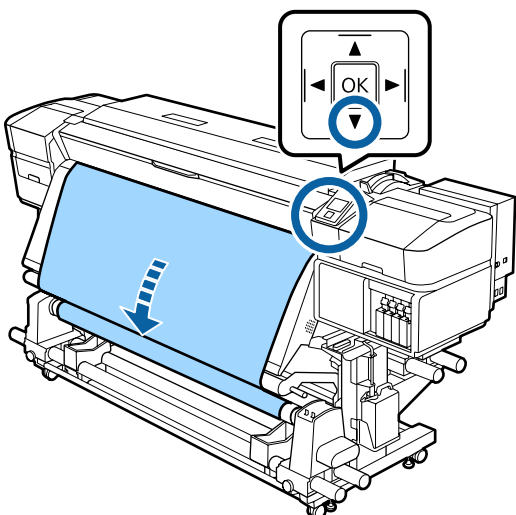

## Settings for Loaded Media

When you have finished loading the media, follow the instructions on the control panel to make settings for the loaded media.

**1. Select the media setting number**

Select the media setting number to which the print settings have been registered.



**2. Select the roll winding specifications**

Select the roll type for the loaded media roll.



**3. Set the media length**

Set the length of the loaded media.

Buttons that are used in the following settings

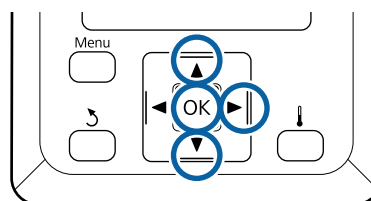

- 1 Use the ▼/▲ buttons to select the media setting number to which the print settings have been registered, and then press the OK button.

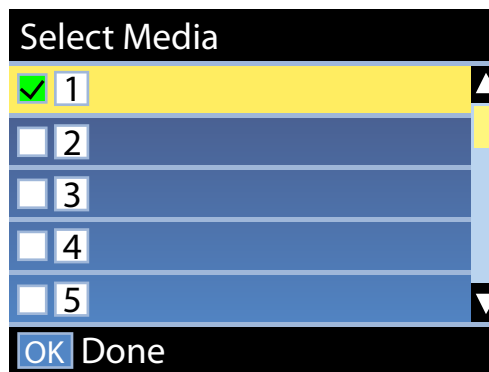

If media settings have not yet been made for new media, select an unassigned number, finish loading the media, and then perform Easy Media Setup.

[“Saving New Media Settings” on page 45](#)

## Basic Operations

- 2 Use the ▼/▲ buttons to select the roll type that matches the loaded roll, and then press the OK button.

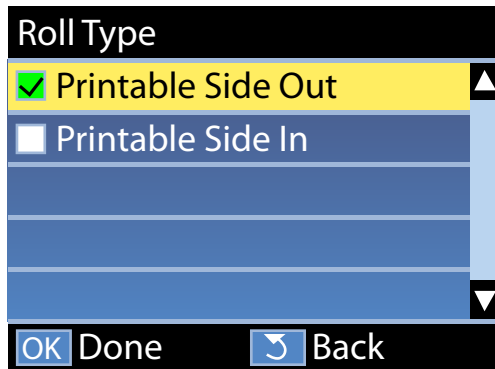

- 3 The screen where you can enter the length of the loaded media is displayed. Use the ▼/▲ buttons to choose a length between 1.0 and 100.0 m and press the OK button.

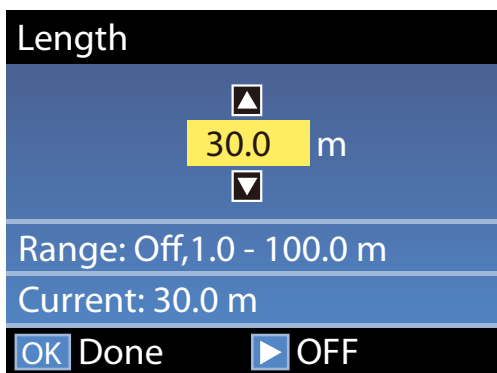

Set the value when remaining amount of media is printed on the roll.

Press the ► button if you want to select OFF. When you select OFF, the remaining amount is not calculated.

**Note:**

**Two functions are enabled in Remaining Setup - ON**

The following two functions give you a rough idea of the amount of media available before printing, making it easier to know when media requires replacement.

- Showing Amount of Media Remaining**  
The control panel display shows the approximate amount of media remaining based on the length set for the media and the amount used during printing.
- Remaining Alert**  
A warning is displayed when the amount of media remaining reaches a specified level.

The printer will display Ready after a brief pause, showing that it is ready to print. Transmit the data to be printed from the computer.

## Saving New Media Settings

### Type and Summary of Media Settings

Each media has its own particular characteristics, such as needing a large amount of ink when printing and taking time to dry. If printing is not done according to these characteristics, you will not get satisfying print results.

You must register the print information and the media setting values that are appropriate for the media you are using to the printer and the RIP to print in the optimal conditions for the media you are using. However, doing many individual settings to be able to print optimally, according to the size and characteristics of the media, can be a complicated and time consuming endeavor.

You can easily, and quickly, register media setting values to the printer using one of the following methods.

### Using EMX Files to Save Media Settings

An EMX file is a print settings file for each media type and includes the following information, which is necessary to print appropriately on commercially available media. This is provided by Epson.

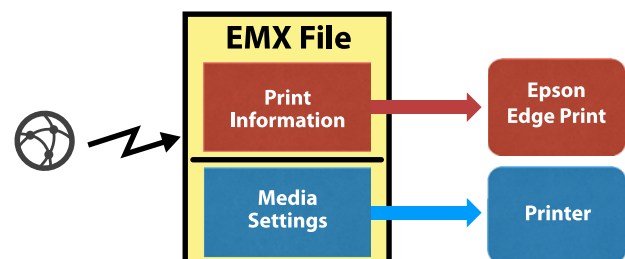

Use the provided software, Epson Edge Dashboard, to download the EMX file and register the media setting values to the printer.

## Basic Operations

When you download the EMX file from Epson Edge Dashboard, the print information is automatically registered to the supplied RIP (Epson Edge Print), so you can use Epson Edge Print to easily perform optimal printing on the media you are using.

When the media setting values are registered to the printer, optimize the media settings on Epson Edge Dashboard. Optimization is the combination (media and printer) you use to compensate for the individual differences of your media and printer, which allows for optimal printing.

 [“Optimization of media settings \(Media Adjust\)” on page 48](#)

**Note:**

See the help for Epson Edge Dashboard for how to download EMX files from Epson Edge Dashboard and how to register media setting values to the printer.

### Performing Easy Media Setup from the printer's setup menu

This is suitable for quick printing. If you select the media type that you loaded, it saves the general-use media setting values that were prepared on the printer in advance. Next, media adjustments are done to optimize the setting values according to the situation, such as for the width of the loaded media and whether the media is loaded on the Auto Take-up Reel Unit.

After doing the easy media setup, select the general-use print information that is already registered to the provided RIP (Epson Edge Print).

Media adjustments operations differ depending on the selected media type.

**When Adhesive Vinyl or Banner are selected: Auto/Manual are available**

We normally recommend selecting **Auto**. This automatically performs feed adjustment and head alignment while printing and reading the media adjustment pattern.

The approximate maximum length of the media required to print the test pattern is given below.

Approx. 270 mm

**When Film, Canvas, Textile, or Paper/Other are selected: perform manual media adjustment**

Visually check the printed adjustment pattern, and then enter the adjustment value.

The approximate maximum length of the media required to print the test pattern is given below.

Feed Adjustment	Approx. 130 mm When <b>Textile</b> is selected, approximately 770 mm
Head Alignment	
In 1 head mode for the SC-S40600 Series/ SC-S80600 Series/ SC-S80600L Series/ SC-S60600 Series/ SC-S60600L Series	Approx. 50 mm* <sup>1</sup>
In 2 head mode for the SC-S80600 Series/ SC-S80600L Series/ SC-S60600 Series/ SC-S60600L Series	Approx. 70 mm* <sup>2</sup>

\*1 In one head mode for 10 color mode in SC-S80600 Series/ SC-S80600L Series when MS installed, approximately 80 mm

\*2 In two head mode for 10 color mode in SC-S80600 Series/ SC-S80600L Series when MS installed, approximately 120 mm

The following explains the procedure for **Easy Media Setup**.

### Easy Media Setup Procedure

Buttons that are used in the following settings

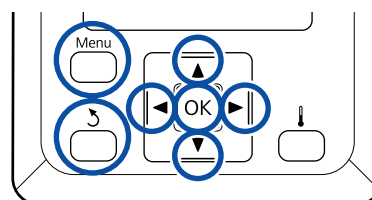

**1** After confirming that the printer is ready, press the **Menu** button.

The settings menu will be displayed.

**2** Select **Media Setup** and press the **OK** button.

## Basic Operations

- 3 Use the ▼ or ▲ button to select **Easy Media Setup**, and then press the OK button.
- 4 Use the ▼/▲ buttons to select the desired media number, and press the OK button.  
If a number with the saved settings is selected, the existing settings are overwritten.
- 5 The setting name is registered.  
Name the media setting bank. Using distinctive names makes it easier to select banks for use.  
Use the ▼/▲ buttons to display letters and symbols. When the desired character is displayed, press the ► button to select the next entry position.  
Mistakes can be erased by pressing the ◀ button to delete the previous character and move the cursor back one spot.
- 6 After entering the name, press the OK button.
- 7 Use the ▼/▲ buttons to select the media type that matches the loaded media, and then press the OK button.  
When **Adhesive Vinyl** or **Banner** is selected, go to step 8.  
When you select anything except for **Adhesive Vinyl** and **Banner**, printing starts for the media adjustment pattern. Go to step 9.
- 8 Use the ▼/▲ buttons to select Auto/Manual for Media Adjust, and then press the OK button.  
When executing **Auto**: An adjustment pattern is printed. When auto adjustment is complete, Easy Media Setup is complete and you are returned to the status display screen.  
When executing **Manual**: An adjustment pattern is printed. When printing is complete, the adjustment value entry screen is displayed. Continue to the next procedure.

- 9 Check the printed adjustment pattern.  
**When anything except for Textile is selected**  
Two groups of adjustment patterns, A and B, are printed. Select the pattern with the least amount of overlapping or gaps for each group. Select "0.0" in the cases shown below.

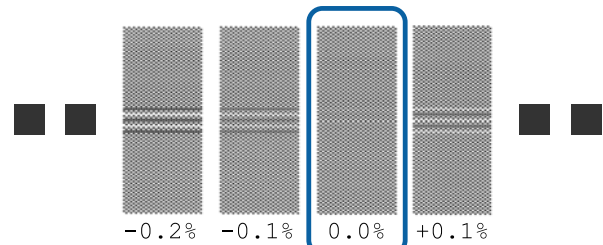

If there are patterns where the overlapping or gaps are the same, enter the middle value in step 10. Enter "-0.05%" in the cases shown below.

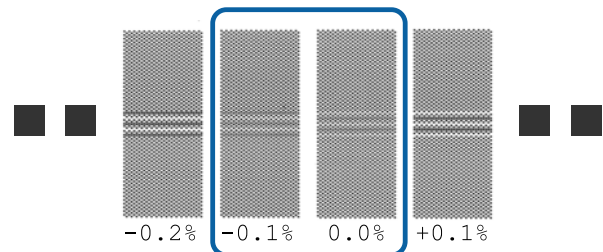

If all of the adjustment patterns contain overlapping or gaps, select the pattern with the least overlaps or gaps.

In this situation, follow the steps below to complete Easy Media Setup, and then perform **500mm Pattern** for media feed adjustment. [🔗 "Feed Adjustment" on page 49](#)

### When Textile is selected:

A 500 mm pattern is printed.

Measure using a scale of up to 0.5 mm.

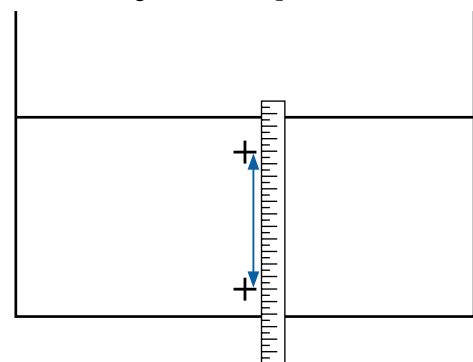

**Basic Operations**

**10** The screen for entering check results for the adjustment pattern is displayed.

**When anything except Textile is selected**

Press the ▼/▲ buttons and set the value printed under the pattern selected in group A from step 9, and then press the OK button.

Set B in the same way.

When printing restarts for the adjustment pattern and printing is complete, the adjustment value entry screen is displayed.

**When Textile is selected**

Set the value measured in step 9, and then press the OK button.

When printing restarts for the adjustment pattern and printing is complete, the adjustment value entry screen is displayed.

**11** Check the printed adjustment pattern.

Model/Status	Adjustment Pattern
<input type="checkbox"/> SC-S40600 Series <input type="checkbox"/> In one head mode for SC-S80600 Series/ SC-S80600L Series/ SC-S60600 Series/ SC-S60600L Series	Two blocks for A and B*1
In two head mode for SC-S80600 Series/ SC-S80600L Series/ SC-S60600 Series/ SC-S60600L Series	Six blocks for A to F*2

\*1 In one head mode for 10 color mode in SC-S80600 Series/SC-S80600L Series when MS installed, four blocks for A to D.

\*2 In two head mode for 10 color mode in SC-S80600 Series/SC-S80600L Series when MS installed, 12 blocks for A to L.

Select the finest lined pattern (all lines overlap) for both. Select "-1" in the cases shown below.

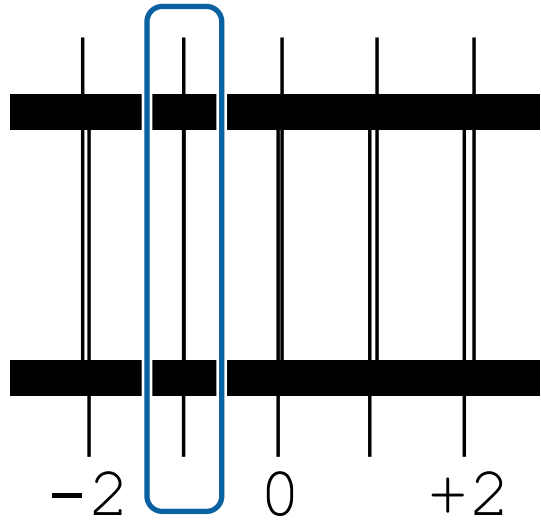

**12** The screen for entering values is displayed.

Using the ▲/▼ buttons, change the value to the value recorded in Step 11, and then press the OK button.

**13** When multiple check patterns have been printed, select the number per check pattern, and then press the OK button.

Using the ▲/▼ buttons, change the value to the value recorded in Step 11, and then press the OK button.

When you enter the final setting, the status display screen is displayed.

**Performing Customize Settings after registration**

After registration, when performing **Media Type** or **Advanced Settings** in **Customize Settings**, you need to perform **Media Adjust** again.

[🔗 “Optimization of media settings \(Media Adjust\)” on page 48](#)

## Optimization of media settings (Media Adjust)

Optimize media settings (Media Adjust) in the following cases.



## Basic Operations

### When registering media setting values on the Epson Edge Dashboard to the printer

When the media setting values of an EMX file downloaded from the Epson Edge Dashboard are registered to the printer, optimization is done so that optimal printing can be carried out with the combination (media and printer) you use to compensate for the individual differences of your media and printer.

### Even after Auto Media Adjust is performed, banding or graininess is found in the print results

Select **Manual**, and then perform **Media Adjust - Standard** and **Head Alignment**.

### When changing Advanced Settings after saving media settings

---

## Notes on Media Adjust

### Adjustments are made according to the media loaded in the printer.

- ❑ Using the actual printing conditions, correctly load the media that needs to be adjusted in the printer. If you are attaching the Auto Take-up Reel Unit to print, place the media on the Auto Take-up Reel Unit during Media Adjust, too.
- ❑ If the media setting values are registered in Epson Edge Dashboard, make sure to use **Select Media** to select the name that was set in **Customize Settings**.

### Make sure nozzles are not clogged before adjusting.

If nozzles are clogged, adjustments will not be performed correctly.

Print to visually inspect the check pattern, and then perform Head Cleaning if necessary.

 [“Checking for clogged nozzles” on page 85](#)



---

## When selecting Adhesive Vinyl or Banner

Do **Auto** in **Media Adjust** for the media selected, either **Adhesive Vinyl** or **Banner**, in **Media Type**. Feed Adjustment and Head Alignment are done automatically while printing the pattern.

The approximate maximum length of the media required to print the test pattern is given below.

Approx. 270 mm

- 1 Check that the printer is ready, and load the media according to the actual usage conditions.  
When using the Auto Take-up Reel Unit, attach the media to the roll core.  
 [“Loading media” on page 30](#)  
 [“Using the Auto Take-up Reel Unit” on page 36](#)
- 2 Press the **Menu** button.  
The settings menu will be displayed.
- 3 Select **Media Setup - Customize Settings - Media Adjust - Auto**.
- 4 When you press OK, auto adjust starts, and an adjustment pattern is printed.  
Wait until adjustment is complete.

---

## When selecting anything other than Adhesive Vinyl or Banner

Do **Feed Adjustment** and **Head Alignment** separately for any media selected, other than **Adhesive Vinyl** or **Banner**, in **Media Type**. Visually check and adjust each printed pattern.

### Feed Adjustment

This menu is also used when banding (horizontal banding, tint unevenness, or stripes) is detected in printing results.

You can select **Standard** or **500mm Pattern** to make adjustments.

#### Standard

Usually, this is selected.

This option is not displayed when selecting **Textile** in **Media Type**.

#### 500mm Pattern

This is useful for making accurate print adjustments when printing on uneven media such as canvas or media that bleeds-through easily, such as cloth.

## Basic Operations

The approximate maximum length of the media required to print the test pattern is given below.

When performing **Standard**: Approximately 130 mm

When performing **500mm Pattern**: Approximately 770 mm

### Setting procedure

**1** Check that the printer is ready, and load the media according to the actual usage conditions.

When using the Auto Take-up Reel Unit, attach the media to the roll core.

 [“Loading media” on page 30](#)

 [“Using the Auto Take-up Reel Unit” on page 36](#)

**2** Press the **Menu** button.  
The settings menu will be displayed.

**3** Select **Media Setup - Customize Settings - Media Adjust - Manual - Feed Adjustment**.

**4** Use the **▼/▲** buttons to select **Standard** or **500 mm**.

**5** Press the **OK** button to print the adjustment pattern.

Wait until printing is complete.

**6** Check the printed adjustment pattern.

#### When Standard is selected

Two groups of adjustment patterns, A and B, are printed. Select the pattern with the least amount of overlapping or gaps for each group. Select "0.0" in the cases shown below.

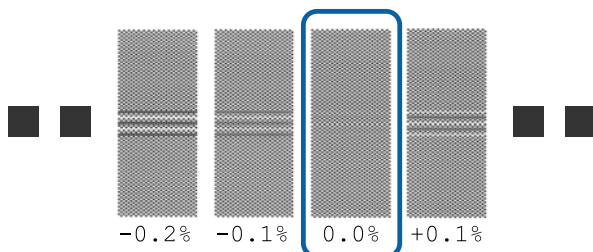

If there are patterns where the overlapping or gaps are the same, enter the middle value in step 7. Enter "-0.05%" in the cases shown below.

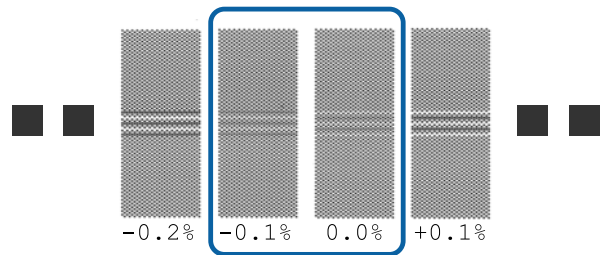

If all of the adjustment patterns contain overlapping or gaps, select the pattern with the least overlaps or gaps.

In this situation, follow the steps below to complete media feed adjustment, and then perform **500mm Pattern** for media feed adjustment.

#### When 500mm Pattern is selected

Measure using a scale of up to 0.5 mm.

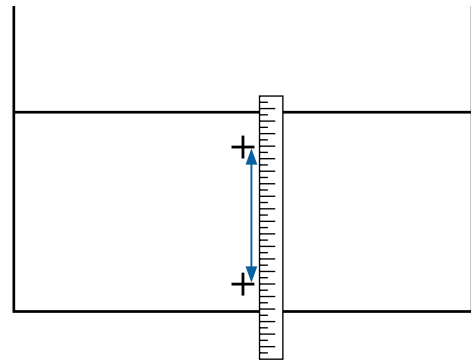

**7** The screen for entering confirmation results for the adjustment pattern is displayed.

#### When Standard is selected

Set the values printed under the patterns selected in A and B, and then press the **OK** button.

#### When 500mm Pattern is selected

Set the value established in step 6, and then press the **OK** button.

When settings are complete, the status display screen is displayed.

## Head Alignment

Depending on the model or setting status being used, the maximum length of the media required to print the test pattern differs as shown below.

### Basic Operations

Model/Status	Length of Media Used
<input type="checkbox"/> SC-S40600 Series <input type="checkbox"/> In one head mode for SC-S80600 Series/SC-S80600L Series/SC-S60600 Series/SC-S60600L Series	Approx. 50 mm*1
In two head mode for SC-S80600 Series/SC-S80600L Series/SC-S60600 Series/SC-S60600L Series	Approx. 70 mm*2

\*1 In one head mode for 10 color mode in SC-S80600 Series/SC-S80600L Series when MS installed, approximately 80 mm

\*2 In two head mode for 10 color mode in SC-S80600 Series/SC-S80600L Series when MS installed, approximately 120 mm

#### Setting procedure

- 1** Check that the printer is ready, and load the media according to the actual usage conditions.  
 When using the Auto Take-up Reel Unit, attach the media to the roll core.  
 ☞ [“Loading media” on page 30](#)  
 ☞ [“Using the Auto Take-up Reel Unit” on page 36](#)
- 2** Press the **Menu** button.  
 The settings menu will be displayed.
- 3** Select **Media Setup - Customize Settings - Media Adjust - Manual - Head Alignment**.
- 4** Press the **OK** button to print the adjustment pattern.  
 Wait until printing is complete.
- 5** Check the printed adjustment pattern.

Model/Status	Adjustment Pattern
<input type="checkbox"/> SC-S40600 Series <input type="checkbox"/> In one head mode for SC-S80600 Series/SC-S80600L Series/SC-S60600 Series/SC-S60600L Series	Two blocks for A and B*1

Model/Status	Adjustment Pattern
In two head mode for SC-S80600 Series/SC-S80600L Series/SC-S60600 Series/SC-S60600L Series	Six blocks for A to F*2

\*1 In one head mode for 10 color mode in SC-S80600 Series/SC-S80600L Series when MS installed, four blocks for A to D.

\*2 In two head mode for 10 color mode in SC-S80600 Series/SC-S80600L Series when MS installed, 12 blocks for A to L.

Select the finest lined pattern (all lines overlap) for both. Select "-1" in the cases shown below.

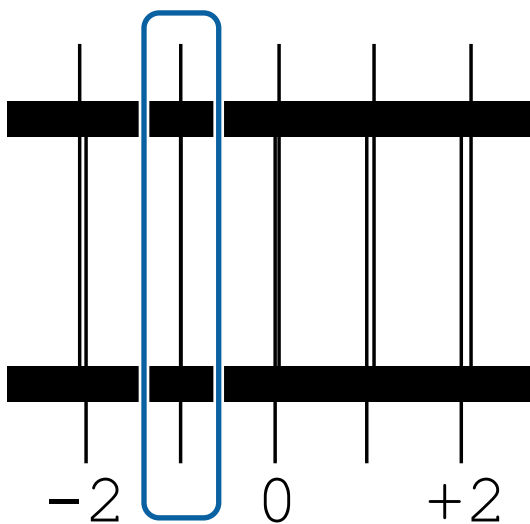

- 6** The screen for entering values is displayed.  
 Using the ▲/▼ buttons, enter the pattern number recorded in Step 5 and press the **OK** button.
- 7** When multiple check patterns have been printed, select the number per check pattern, and then press the **OK** button.

The media setup menu will be displayed when you enter the pattern number for the last color.

## Removing the Take-up Roll

Follow the steps below when replacing the media.

## Basic Operations

**1. Print the remaining amount of media. (When Media Remaining is set to ON)**



**2. Cut the media.**



**3. Remove the media.**

## Printing the Amount of Media Remaining

By printing the remaining amount on the media being removed, you can check this value the next time the media is loaded and enter the media length. This is useful for accurate management of the amount of media remaining. The remaining amount cannot be printed when **Remaining Setup** is set to **OFF**.

The following section describes how to print the amount of media remaining.

Buttons that are used in the following settings

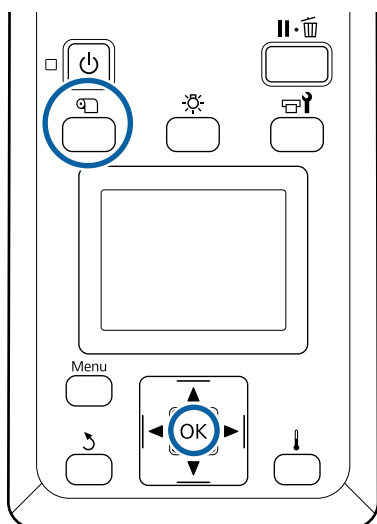

- 1** Confirm that the printer is ready to print.
- 2** Press the  button, select **Media Remaining**, and then press the OK button.

- 3** Select **Print Remaining Length** and press the OK button.

- 4** Press the OK button to print the amount of media remaining.

## Cutting Media

### **Caution:**

- The heaters and media edge plate may be hot; observe all necessary precautions. Failure to observe the necessary precautions could result in burns.
- When cutting media, be careful not to cut your fingers or hands with the cutter or other blades.

- 1** Press the  button, select **Feed To Cut Position**, and then press the OK button.

The trailing edge of the print is fed to the cut position (cutter groove).

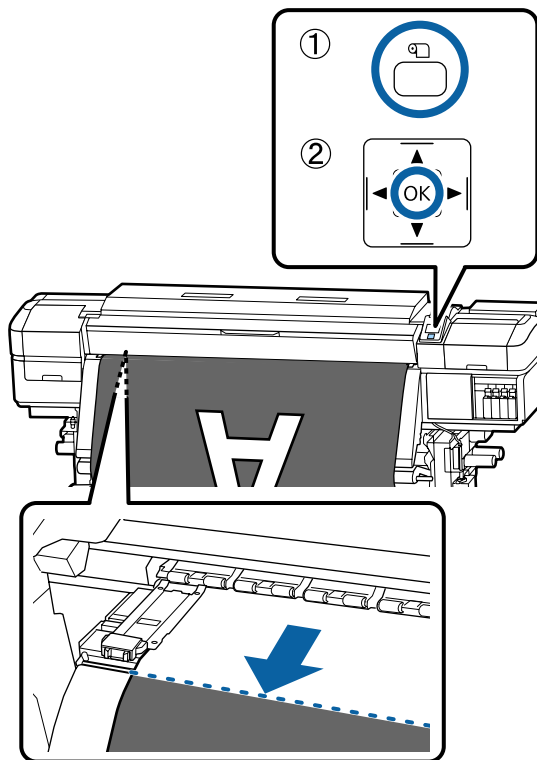

If you have printed the amount of media remaining, press the  button to rewind the media until this information appears on the roll side beyond the cutter groove so that it will remain on the roll after the media is cut.

### Basic Operations

- 2** When using the Auto Take-up Reel Unit, raise the tension bar.

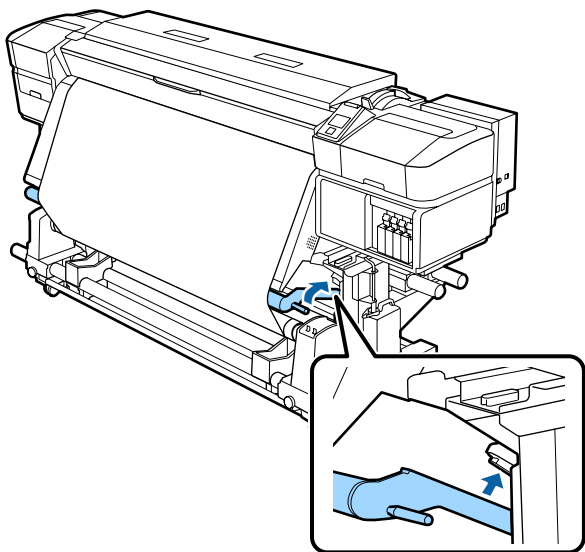

- 3** Raise the cutter, and then move it so that the cutter blade fits the cutter groove properly.
- If you cannot position your hand correctly due to the front cover, open the front cover and then cut.

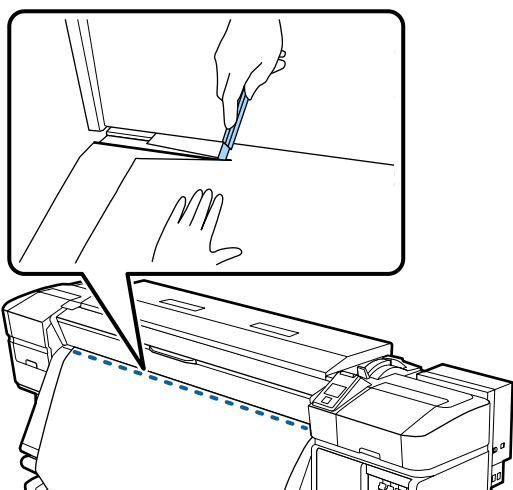

**!** **Important:**

When you cut the media, check that it does not rise up inside the front cover or has not come free from the media edge plate before printing.

- 4** Set the Auto switch to Off. Take up the cut media completely by operating the Manual switch according to how the media is rolled.

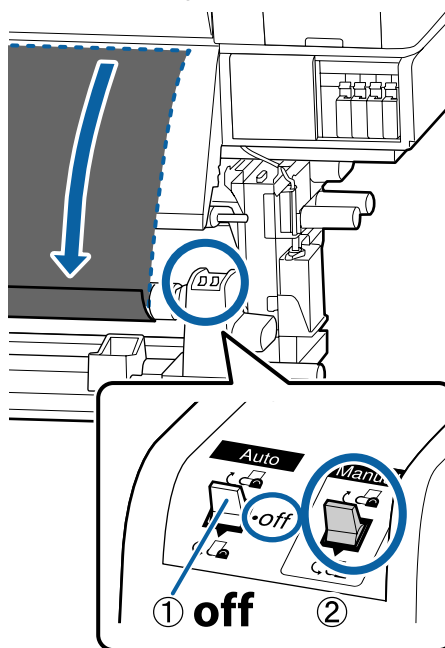

### Removing Media

**!** **Caution:**

- ❑ If the media weighs over 20 kg, it should not be carried by one person. When loading or removing the media, use at least two people.
- ❑ Follow the instructions in the manual when loading media or roll cores or removing the take-up roll. Dropping media, roll cores, or take-up rolls could result in injury.

- 1** To prevent the media from sliding off the roll, support the roll at its left end.
- 2** Loosen the left roll core holder fixing screw and remove the roll core holder from the roll.

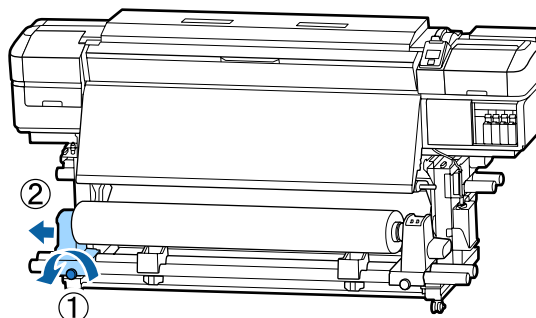

## Basic Operations

- 3** Lower the roll onto the roll support.

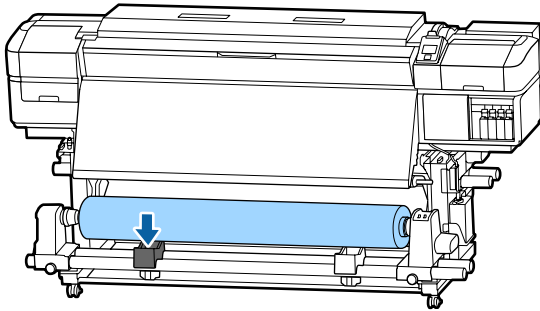

- 4** To prevent the media from sliding off the roll, support the roll at its right end.

- 5** Loosen the right roll core holder fixing screw and remove the roll core holder from the roll.

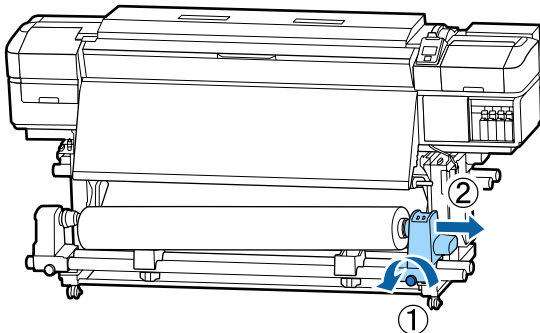

- 6** Lower the roll onto the roll support.

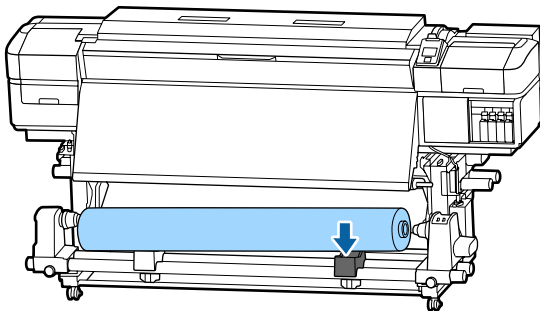

- 7** To remove media from the rear media feeding unit, reverse the steps you followed to load it.

## Before Printing

To maintain print quality, perform the following inspection before starting work each day.

### Check the amount of ink remaining:

If ink is expended while printing, printing can be resumed once the affected ink cartridge/ink supply unit has been replaced. However, when replacing ink during a print job, you may see a difference in color depending on the drying conditions. If you know that the print job will be a large one, we recommend that you use new ink cartridges/ink supply units to replace those that are running low before you start. The old ink cartridges/ink supply units can be re-inserted and used at a later date.

Ink level is shown by an icon. [☞ “Understanding the Display” on page 16](#)

Replacing Ink Cartridges [☞ “Replacement procedure” on page 72](#)

Replacing Ink Supply Units [☞ “Replacement procedure” on page 75](#)

### Shaking WH/MS inks (when 10 color mode is selected in SC-S80600 Series/SC-S80600L Series)

WH/MS inks may sediment easier than other inks due to ink characteristics.

Before starting printing operations for the day, remove the ink cartridges/ink supply units and thoroughly shake them back and forth approximately 15 times in 5 seconds.

Shaking Ink Cartridges [☞ “Shaking” on page 71](#)

Shaking Ink Supply Units [☞ “Shaking” on page 74](#)

### Print Check Pattern

Print a check pattern to check for clogged nozzles.

Perform head cleaning if parts of the pattern are faint or missing.

Print a Check Pattern [☞ “Printing nozzle check patterns” on page 86](#)

Head Cleaning [☞ “Head Cleaning” on page 86](#)

## Basic Operations

# Changing settings during printing

## Changing the Heater Temperature and Drying Settings

Buttons that are used in the following settings

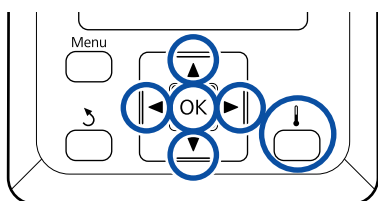

- 1 Press the [  ] button during printing.  
The **Heating & Drying** menu is displayed.
- 2 Use the ▼/▲ buttons to select the desired item and press the OK button.
- 3 Choose a value.
  - Heater Temperature**
  - (1) Use the ►/◄ buttons to select a heater. From left, the items are pre-heater, platen heater, and after heater.
  - (2) After selecting the desired heater, use the ▼/▲ buttons to choose the temperature.
- Additional Dryer**  
Use the ▼/▲ buttons to select items.
- 4 When you press the OK button, the settings for the currently selected media are updated, and the Heating & Drying menu is displayed.
- 5 When you press the ⏏ button, the menu is closed and the status display screen is displayed.

**Note:**

*The time needed for the heaters to reach the specified temperatures varies with the ambient temperature.*

## Correcting Banding

When you want to correct banding during printing, perform Feed Adjustment.

Buttons that are used in the following settings

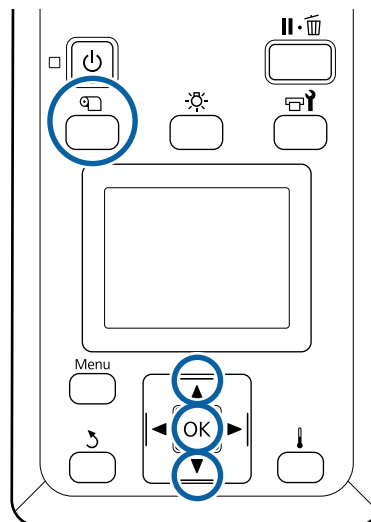

- 1 Press the  button during printing.  
The current adjustment value is displayed.
- 2 Use the ▼/▲ buttons to change the current value.  
If the feed amount is too small, black bands (dark stripes) will appear; adjust the feed amount upwards.  
If, in contrast, the feed amount is too large, white bands (pale stripes) will appear; adjust the feed amount downwards.
- 3 Check the printing result. If you are not satisfied with the results, use the ▼/▲ buttons to change the value.  
This updates the setting value of **Feed Adjustment** in the currently selected media settings.

## Basic Operations

- 4 Press the **OK** button to display the status display screen.

**Note:**

If the setting is changed, the icon is displayed on the control panel screen as shown below. To clear this icon, carry out the following operations.

- Restart **Feed Adjustment**.
- Execute **Restore Settings**.

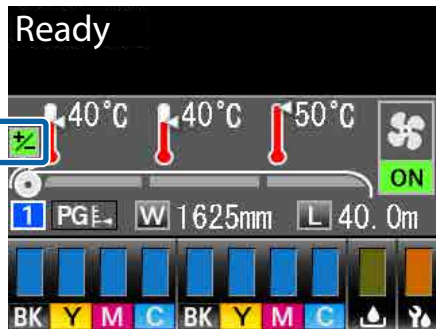

When you have finished the target print, we recommend performing **Media Adjust** from the setup menu.

[“Optimization of media settings \(Media Adjust\)” on page 48](#)

## Checking Details for the Remaining Amount of Ink and Wiper Units

When you want to check details for the following while printing, display the amounts remaining.

- Remaining ink level
- Space available in the Waste Ink Bottle
- Remaining wiper units

Buttons that are used in the following settings

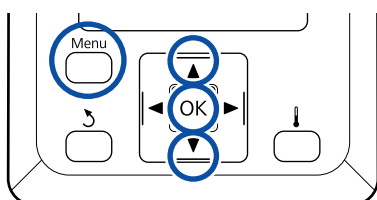

- 1 Press the **Menu** button during printing.  
The settings menu will be displayed.
- 2 Use the **▼/▲** buttons to select **Printer Status**, and then press the **OK** button.
- 3 Use the **▼/▲** buttons to select the item you want to check, and then press the **OK** button.
- 4 The current status is indicated by an icon.
- 5 When you press the **OK** button after checking, the previous screen is displayed.



## Basic Operations

# Printable area

The left and right edges of media recognized by the printer varies as shown below according to the Media Size Check settings.

Media Size Check **ON** : The printer automatically detects the left and right edges of the loaded media.

When media edge plates are attached, within 5 mm of the left and right edges of the media is recognized as the media edge.

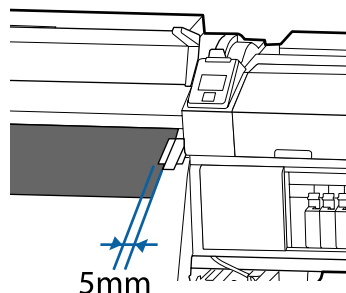

The edges of the media are not detected correctly if the media edge plates are not attached correctly.

 [“Loading media” on page 30](#)

Media Size Check **OFF** : The center of the black rectangle on the after heater's label (shown in the illustration below) is the standard position for the right edge of the media. Regardless of the width of the loaded media, the left edge of the media is determined to be 1,626 mm (64 inches) from the standard position for the right edge.

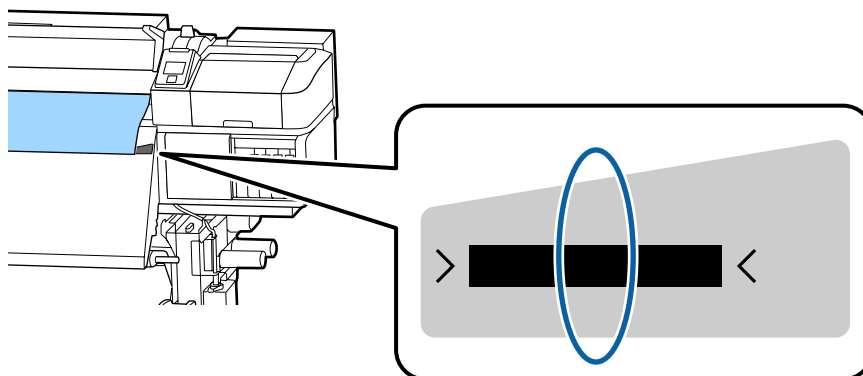

### Basic Operations

The gray area in the illustration below shows the printable area. The arrow indicates the feed direction.

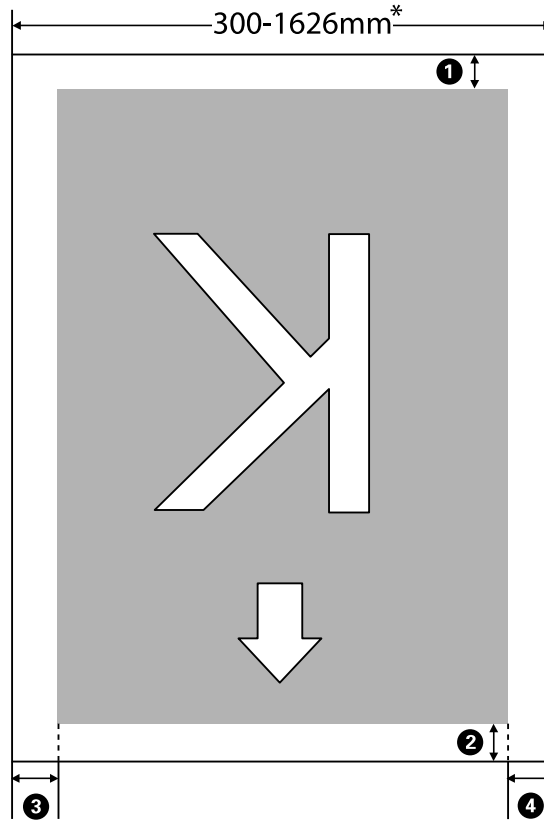

\* When Media Size Check is set to OFF, this is 1,626 mm (64 inches) regardless of the width of the loaded media.

① to ④ indicates the margins on all four sides. See the following for more details.

Margin Position	Explanation	Available Setting Range
① Rear <sup>*1</sup>	This can be set in RIP. To maintain media feeding accuracy, if the settings are less than 5 mm or more than 17 mm, the settings are switched to 5 mm and 17 mm respectively.	5 to 17 mm
② Leading edge <sup>*1</sup>	This can be set in RIP. Differs by the length the media was pulled when the media is loaded. For continuous printing, although the margins set in RIP are added, to maintain media feeding accuracy, if the setting is less than 5 mm the setting is switched to 5 mm.	5 mm or more
③ Left edge <sup>*2, *3</sup>	The value selected for Side Margin(Left) in the printer's setup menu. The default setting is 5 mm.	3 to 25 mm
④ Right edge <sup>*2, *3</sup>	The total of the values selected for Print Start Position and Side Margin(Right) in the printer's setup menu. The default setting for Print Start Position is 0 mm and Side Margin(Right) is 5 mm.	3 to 825 mm

\*1 The set margin and the actual print results may differ depending on the RIP being used. Contact the RIP manufacturer for more information.

## Basic Operations

- \*2 This may be available in the RIP depending on the RIP software being used. Contact the RIP manufacturer for more information.
- \*3 Note the following points when setting margins.
  - Leave margins of 10 mm or more when using media edge plates. Narrower margins could result in printer printing over the plates.
  - If the total of the print data width and set left and right margins exceeds the printable area, a portion of the data will not be printed.

**Note:**

*If the following points are not observed when Media Size Check is **OFF**, printing may occur outside the left and right edges of the media. Ink used outside the edges of the media will stain the inside of the printer.*

- Ensure that the print data width does not exceed the loaded media width.*
- When media is loaded to the left of the right side reference position, align the **Print Start Position** setting with the position where the media set.*  
* [“The Printer Setup Menu” on page 108](#)*

Maintenance

# Maintenance

## When to Perform Various Maintenance Operations

### Cleaning Locations and Cleaning Timing

If you continue to use the printer without cleaning, it could cause clogged nozzles or ink drops to occur.

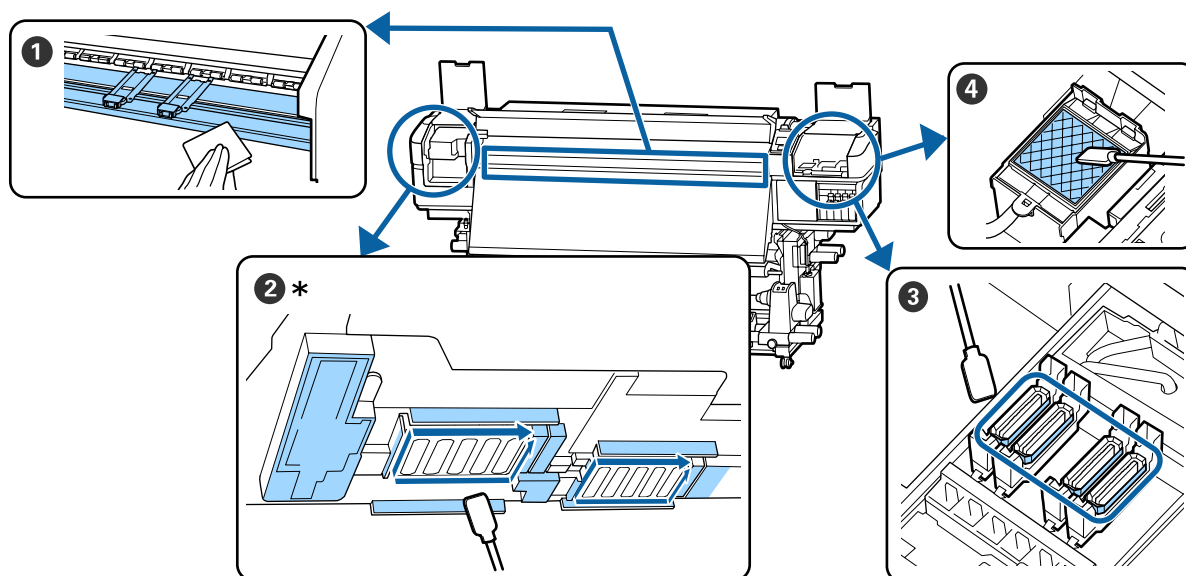

\* Right print head only in SC-S40600 Series.

When to perform	Component to be cleaned
When starting work every day	<p>① Platen heater and media edge plates</p> <p><a href="#">☞ "Daily Cleaning" on page 64</a></p>
At least once a month	<p>② Around the Print Head</p> <p>③ Caps</p> <p>④ Flushing pad (when dirty)</p> <p><a href="#">☞ "Performing Regular Cleaning" on page 65</a></p> <p>You can check the procedure in a video on YouTube.</p> <p><a href="#">Epson Video Manuals</a></p>

**!** **Important:**

*The printer contains precision instruments. If any lint or dust adheres to the nozzles on the print head, print quality will decline.*

*Perform regular cleaning more frequently depending on the environment and media being used.*

Maintenance

Locations of Consumables and Replacement Timing

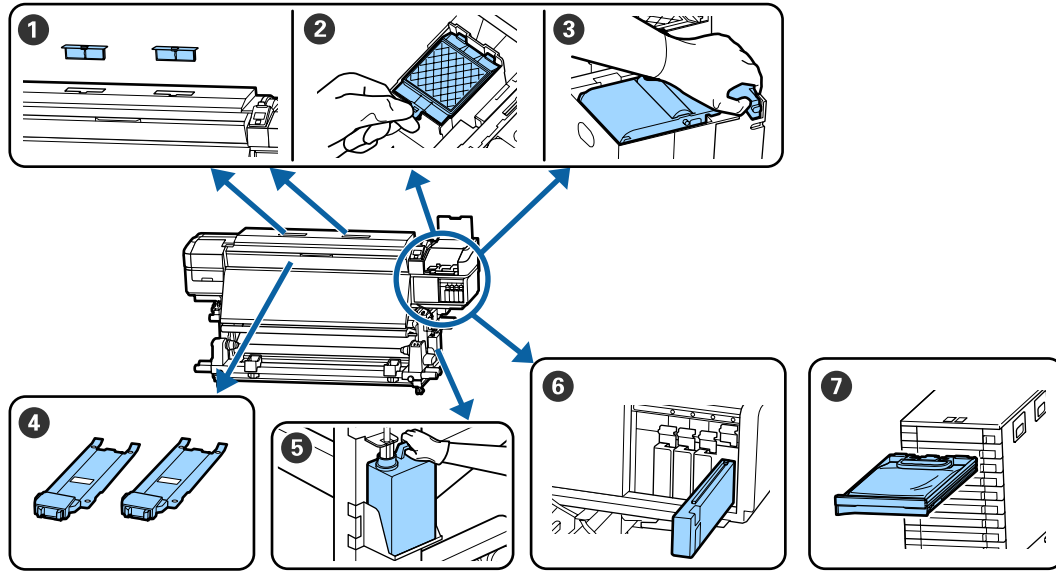

When to perform	Component to be replaced
When a prepare and replacement message is displayed on the control panel screen	<ul style="list-style-type: none"> <li>① Air filters</li> <li>② Flushing pad</li> <li>③ Wiper unit</li> <li>☞ <a href="#">"Replacing Maintenance Parts" on page 79</a></li> <li>⑤ Waste Ink Bottle</li> <li>☞ <a href="#">"Disposing of Waste Ink" on page 77</a></li> </ul>
When an error appears on the control panel screen indicating ink is expended	<ul style="list-style-type: none"> <li>⑥ Ink cartridge (SC-S80600 Series/SC-S60600 Series/SC-S40600 Series)</li> <li>☞ <a href="#">"Replacement procedure" on page 72</a></li> <li>⑦ Ink Supply Unit (SC-S80600L Series/SC-S60600L Series)</li> <li>☞ <a href="#">"Replacement procedure" on page 75</a></li> </ul>
When the plates are deformed or damaged.	<ul style="list-style-type: none"> <li>④ media edge plates</li> <li>☞ <a href="#">"Replacing the media edge plates" on page 82</a></li> </ul>

Other maintenance

When to perform	Operation
When using SC-S80600 Series/SC-S60600 Series/SC-S40600 Series <input type="checkbox"/> Once every three weeks <input type="checkbox"/> Before starting operations for the day (WH/MS only)*	Shaking ink cartridges ☞ <a href="#">"Shaking" on page 71</a>

### Maintenance

When to perform	Operation
When using SC-S80600L Series/ SC-S60600L Series <ul style="list-style-type: none"> <li><input type="checkbox"/> When LED lamp on ink unit flashes blue (once every 3 weeks)</li> <li><input type="checkbox"/> Before starting operations for the day (WH/MS only)*</li> </ul>	Shaking Ink Supply Units <a href="#">☞ "Shaking" on page 74</a>
<ul style="list-style-type: none"> <li><input type="checkbox"/> When checking if nozzles are clogged</li> <li><input type="checkbox"/> When checking which colors are clogged</li> <li><input type="checkbox"/> Horizontal stripes or tint unevenness (banding) are appeared.</li> </ul>	Checking for clogged nozzles <a href="#">☞ "Checking for clogged nozzles" on page 85</a>
When a clog is found after checking for clogged nozzles	Head Cleaning <a href="#">☞ "Head Cleaning" on page 86</a>
When the printer will not be used for an extended period (and switched off)	Pre-Storage Maint. <a href="#">☞ "Long-term Storage (Pre-storage Maintenance)" on page 88</a>
(SC-S80600 Series/SC-S80600L Series only) <ul style="list-style-type: none"> <li><input type="checkbox"/> When changing the spot color to use (WH &lt;=&gt; MS)</li> <li><input type="checkbox"/> When changing between 10 color mode and 9 color mode</li> </ul>	Change Color Mode <a href="#">☞ "Change Color Mode (SC-S80600 Series/SC-S80600L Series only)" on page 90</a>
When dirt from rollers adheres to print outs	Pressure rollers <a href="#">☞ "Cleaning pressure rollers" on page 91</a>
When it is hard to see inside the printer	Inside the front cover <a href="#">☞ "Cleaning inside the front cover" on page 91</a>
When a greasing message is displayed on the control panel	Applying the supplied grease to the carriage rod <a href="#">☞ "Applying Grease to the Carriage Rod" on page 92</a>

\* When 10 color mode is selected on SC-S80600 Series/SC-S80600L Series.

## Maintenance

### What You'll Need

Ready the following items before beginning cleaning and replacement.

When the supplied parts have been completely used, purchase new consumables.

Prepare dedicated parts for this printer when replacing ink cartridges/ink supply units or performing maintenance.

 [“Options and Consumable Products” on page 124](#)

If your gloves have worn out, prepare commercially available nitrile gloves.

#### Protective eyeglasses (available in the market)

Protects your eyes from ink and ink cleaner.

#### Mask (available in the market)

Protects your nose and mouth from ink and ink cleaner.

#### Maintenance Kit (supplied with the printer)

For general cleaning.

The following items are in the kit.

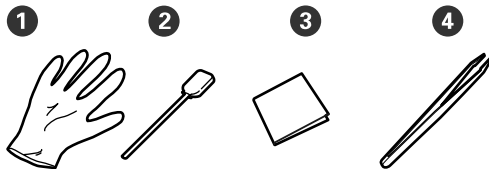

- ① Gloves (x12)
- ② Cleaning sticks (x20)
- ③ Clean-room wipers (x100)
- ④ Tweezers (x1)

#### ink cleaner (supplied with the printer)

Use when wiping ink stains.

Usage method  [“Using ink cleaner” on page 65](#)

#### A metal tray (supplied with the printer)

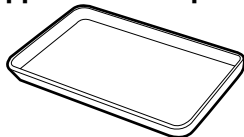

Use when putting cleaning utensils, removed consumables, or ink cleaner moved in the container supplied with the printer.

#### Important:

*If the used cleaning stick, etc. are directly put on the printer, it may cause a deformation from the characteristics of the ink cleaner.*

#### Soft cloth (commercially available)

Use when cleaning inside the printer. We recommend an item that is not likely to generate lint or static electricity.

#### Grease kit (supplied with the printer)

Use when applying grease to the carriage rod.

The following items are in the kit.

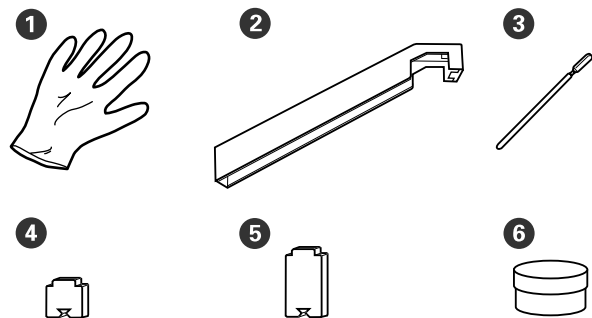

- ① Gloves (x16)
- ② Grease tool (x1)
- ③ Cleaning sticks (x8)
- ④ Pad A (x16)
- ⑤ Pad B (x16)
- ⑥ Grease (x2)

### Precautions regarding maintenance

Note the following points when cleaning and replacing parts.

## Maintenance

### **Caution:**

- ❑ Store ink cartridges, ink supply units, cleaning cartridges, cleaning ink supply units, ink cleaner, grease, and waste ink out of the reach of children.

- ❑ During maintenance, wear protective clothing, including protective eyewear, gloves, and a mask.

*If ink, waste ink, ink cleaner, or grease contact your skin or enter your eyes or mouth, take the following actions:*

- ❑ *If fluid adheres to your skin, immediately wash it off using large volumes of soapy water. Consult a physician if the skin appears irritated or is discolored.*
- ❑ *If fluid enters your eyes, rinse immediately with water. Failure to observe this precaution could result in bloodshot eyes or mild inflammation. If problems persist, consult with a physician.*
- ❑ *If fluid enters your mouth, consult a physician immediately.*
- ❑ *If fluid is swallowed, do not force the person to vomit, and consult with a physician immediately. If the person is forced to vomit, fluid may get caught in the trachea which can be dangerous.*
- ❑ *After replacing the Waste Ink Bottle or using the ink cleaner, wash your hands and gargle thoroughly.*

- ❑ Remove the media from the printer before proceeding.
- ❑ Never touch the belts, circuit boards, or any parts that do not require cleaning. Failure to observe this precaution could result in malfunction or reduced print quality.
- ❑ Use only the supplied cleaning sticks or sticks contained in a maintenance kit. Other types of sticks that produce lint will damage the print head.
- ❑ Always use fresh cleaning sticks. Re-using sticks can make stains even harder to remove.
- ❑ Do not touch the tips of the cleaning sticks. Oil from your hands could damage the print head.

- ❑ Do not use water or alcohol to clean around the print head or the caps and so on. Ink congeals when mixed with water or alcohol.
- ❑ Touch a metallic object before starting work to discharge any static electricity.

## Daily Cleaning

When lint, dust, or ink adheres to the platen heater or the media edge plates, it could cause clogged nozzles or ink drops to occur.

To maintain optimum printing quality, we recommend cleaning before starting work every day.

### **Caution:**

- ❑ *The heaters and media edge plate may be hot; observe all necessary precautions. Failure to observe the necessary precautions could result in burns.*
- ❑ *Be careful not to trap your hands or fingers when opening or closing the front cover. Failure to observe this precaution could result in injury.*

### **Important:**

*When cleaning inside the printer, do not use ink cleaner. Failure to observe this precaution could result in damaged parts.*

- 1 Make sure the printer is turned off and the screen has turned off, and then unplug the power cable from the outlet.

Disconnect both of the power cables.

If the additional print drying system is installed, make sure you unplug the power cable for the additional print drying system as well.

- 2 Leave the printer for a minute.

- 3 Open the front cover.



**Maintenance**

- 4** Soak a soft cloth in water, wring it out thoroughly, and then wipe off any ink, lint, or dust that has adhered to the platen heater.

Carefully remove lint and dust stuck in the groove of the platen.

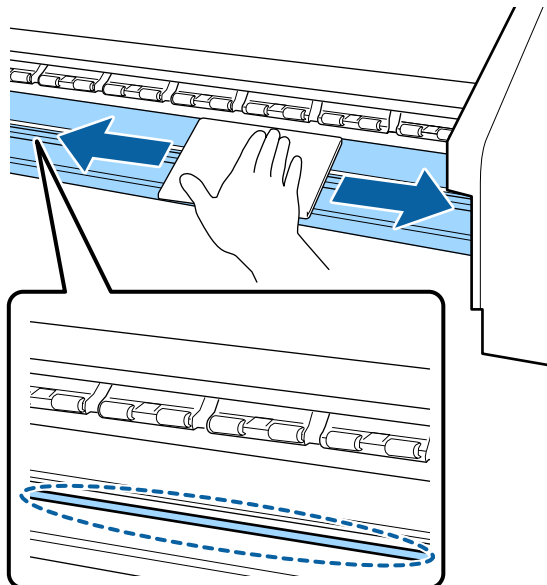

- 5** Soak a soft cloth in water, wring it out thoroughly, and then wipe off any lint, or dust that has adhered to the media edge plates.

**! Important:**

When media with glue has been used, wipe away glue using a diluted neutral detergent. If you continue printing while glue is stuck to the rear, it may rub against the print head.

**When using media with glue and when ink adheres**

Remove the media edge plates from the printer, and clean the front and back of the plates.

When stains are removed, be sure to attach the plates to their original positions.

Removing and attaching the media edge plates [“Replacing the media edge plates” on page 82](#)

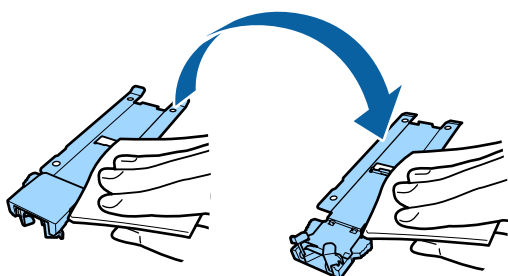

## Performing Regular Cleaning

Clean the parts in the following order.

**Moving the Print Head**



**Cleaning Around the Print Head**



**Cleaning Around the Caps**

**! Important:**

The following message is displayed on the control panel display if cleaning has not been performed for one month. When the message is displayed, perform regular cleaning as soon as possible.

Press and perform **Head Maintenance**.

## Using ink cleaner

Only use ink cleaner to clean the parts indicated in the manual. Using ink cleaner on other parts of the printer could damage the product.

Before starting this procedure, be sure to read the following:

[“Precautions regarding maintenance” on page 63](#)

- 1** Put the cup supplied with the ink cleaner on the metal tray, and pour approximately 10 ml of ink cleaner into the cup.

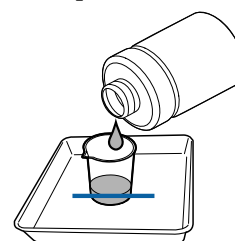

## Maintenance

- 2 Dampen the cleaning stick with ink cleaner.  
Do not allow ink cleaner to drip from the cleaning stick.

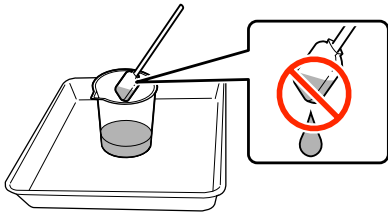

When dampening a clean-room wiper with ink cleaner, use ink cleaner poured into a cup.

### ! Important:

- ❑ Do not reuse ink cleaner. Using dirty ink cleaner will make staining worse.
- ❑ Used ink cleaner, cleaning stick, and clean-room wipers are industrial waste. Dispose of them in the same way as for waste inks.  
[↗ "Disposal of used consumables" on page 84](#)
- ❑ Store ink cleaner at room temperature out of direct sunlight.
- ❑ After using the ink cleaner, be sure to close the cap. Failure to securely close the cap may cause a leakage or volatilization of the ink cleaner.

## Moving the Print Head

This section describes how to move to cleaning position of the print head.

### ! Important:

Be sure to follow the steps below when positioning the print head. Moving the print head manually could cause malfunction.

Buttons that are used in the following settings

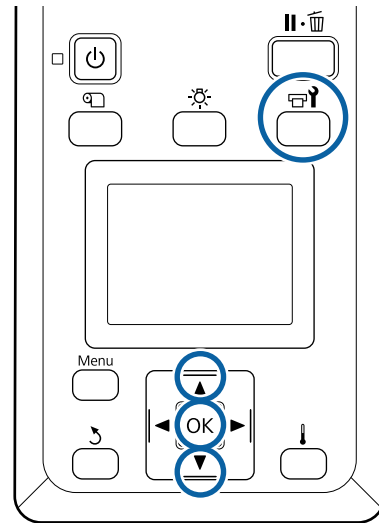

- 1 Confirm that the printer is on and press the button.  
The Maintenance menu will be displayed.
- 2 Use the / buttons to select **Head Maintenance** and press the OK button.
- 3 Use the / buttons to select **Regular Cleaning**, and then press the OK button.  
The print head moves to the cleaning position.

### Note:

The buzzer sounds 10 minutes after the print head is moved (default setting). Press the OK button to continue the cleaning process. After 10 more minutes have passed, the buzzer sounds again.

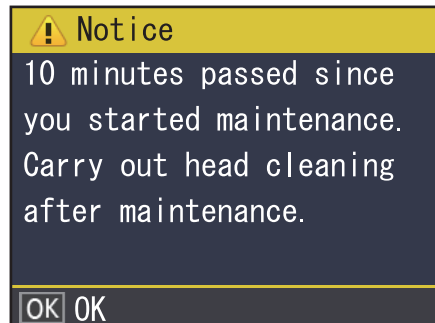

## Maintenance

### Cleaning Around the Print Head

If you notice any ink clots, lint, or dust when checking the area around the print head, clean the area by following the steps below.

The SC-S80600 Series/SC-S80600L Series/SC-S60600 Series/SC-S60600L Series have 2 print heads. Clean around both print heads.

Before starting this procedure, be sure to read the following:

 [“Precautions regarding maintenance” on page 63](#)

- 1 After the print head moves to the left end of the printer, open the left maintenance cover.

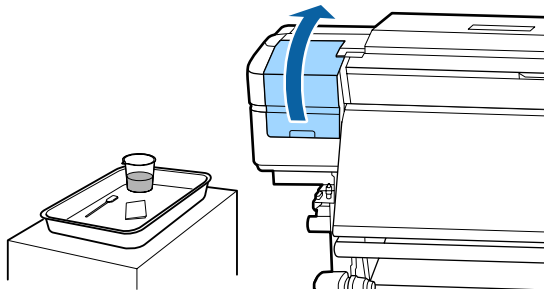

- 2 Dampen the cleaning stick with ink cleaner. Use new cleaning stick and ink cleaner.

 [“Using ink cleaner” on page 65](#)

 **Important:**

- Rinse a cleaning stick using ink cleaner for each step.
- After removing a clot of ink with a cleaning stick, wipe off using a clean-room wiper.

- 3 Wipe off any adhered ink, lint, and dust from the parts that are indicated by the arrows below.

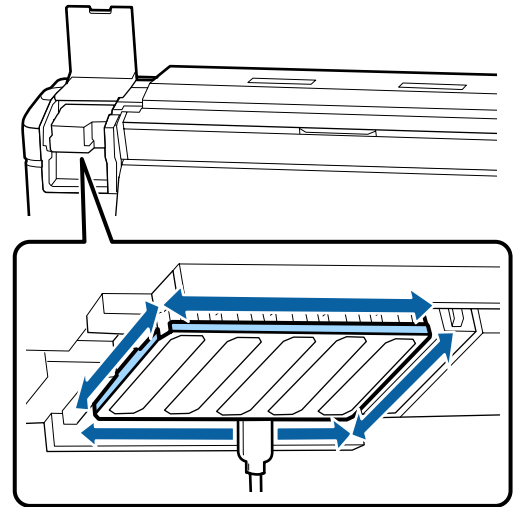

- 4 Wipe off any adhered ink, lint, and dust from the parts that are indicated by  below. Right print head only in SC-S40600 Series.

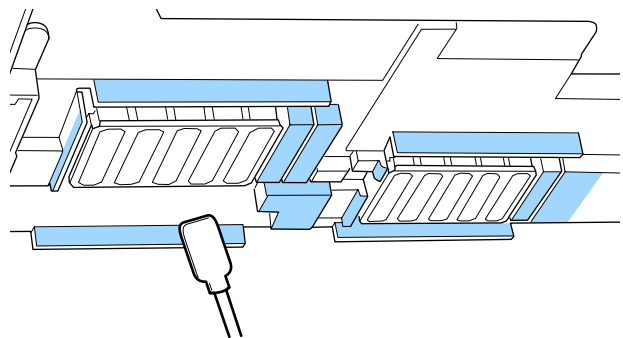

- 5 Wipe off any adhered ink, lint, and dust from the parts that are indicated by  below.

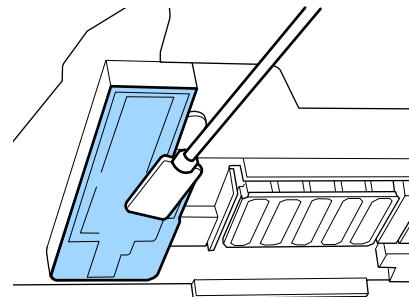

- 6 Close the left maintenance cover.

### Cleaning Around the Caps

Before starting this procedure, be sure to read the following:

## Maintenance

 "Precautions regarding maintenance" on page 63

### Cleaning Caps

- 1 Open the right maintenance cover.

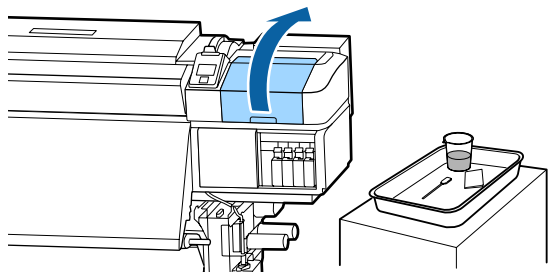

- 2 Dampen the cleaning stick with ink cleaner.

 "Using ink cleaner" on page 65

- 3 Hold the cleaning stick flat and wipe the edges of all the caps.

The SC-S80600 Series/SC-S80600L Series/SC-S60600 Series/SC-S60600L Series have 2 blocks of caps. Clean all of the caps.

#### Important:

*Do not push strongly against the edges or the surrounding area of the cap, or touch the inner side of the cap with a cleaning stick or tweezers. The part may be deformed, and it may no longer be possible to perform capping correctly.*

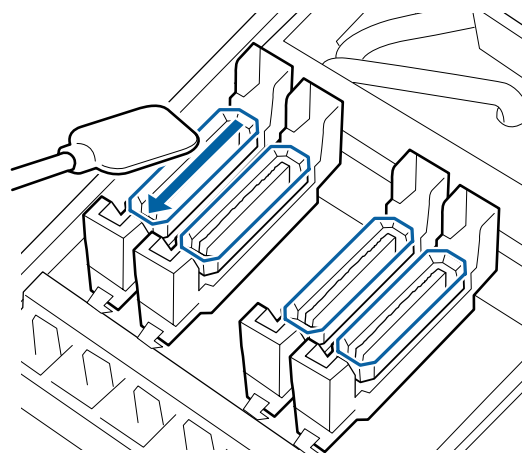
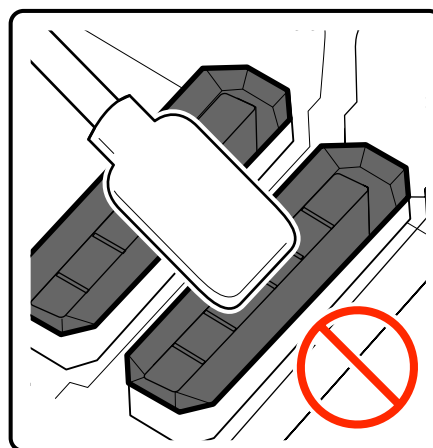

## Maintenance

- 4** Hold the cleaning stick in a perpendicular orientation, and wipe the outer areas of all the caps.

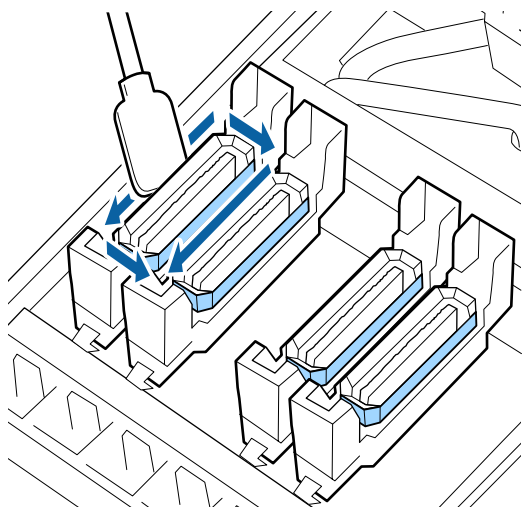

### Points to note when cleaning caps

Check the following points when cleaning the caps.

- Has ink adhered to the guide section in front of and behind the cap?

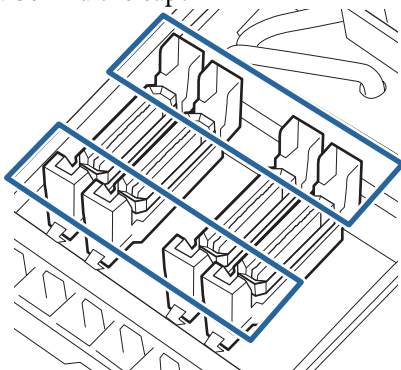

- Has a film of ink adhered to the guide section?
- Is there any lint attached to the inside of the cap?
- Is there any lint attached to the flushing pad?

If they do not require cleaning, the procedure is complete.

 [“Finishing Cleaning” on page 71](#)

If they require cleaning, see the following sections and perform the necessary cleaning.

## When ink adheres to the guide section

- 1** Dampen the cleaning stick with ink cleaner.  
 [“Using ink cleaner” on page 65](#)

- 2** Apply ink cleaner to the guide section, and then wipe it down.

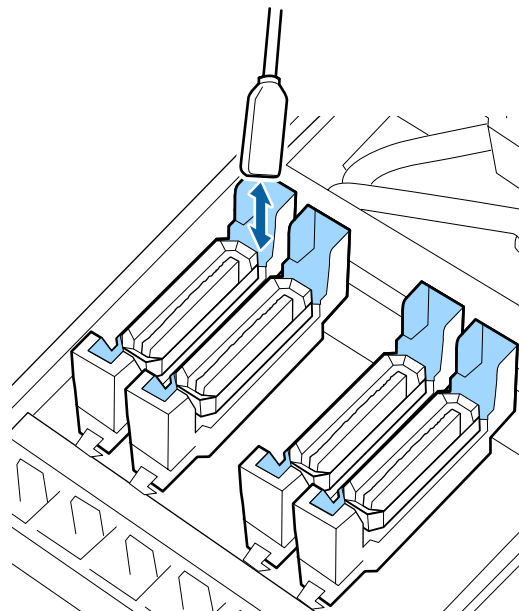

If no other parts need to be cleaned, proceed to the following section.

 [“Finishing Cleaning” on page 71](#)

**Maintenance**

**When a film of ink adheres to the guide section**

If a film-like layer of adhered ink cannot be removed completely using a cleaning stick, remove it using tweezers.

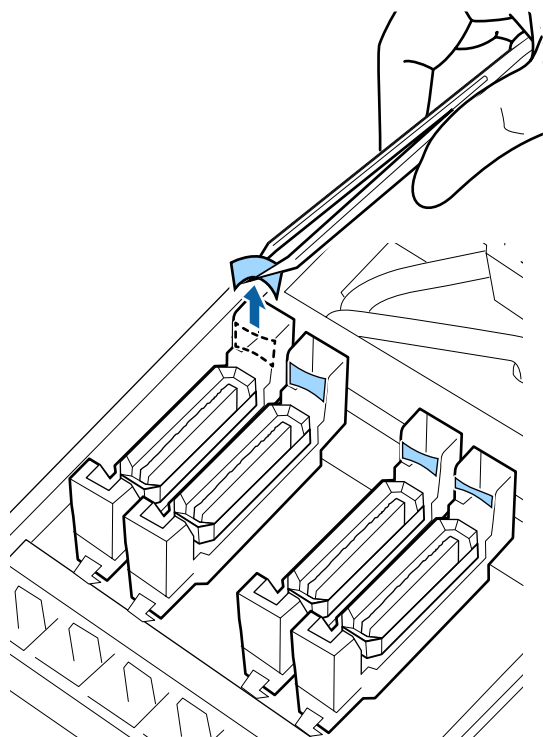

If no other parts need to be cleaned, proceed to the following section.

 [“Finishing Cleaning” on page 71](#)

**When there is lint or dust in the cap**

Remove using the tip of the cleaning stick or tweezers.

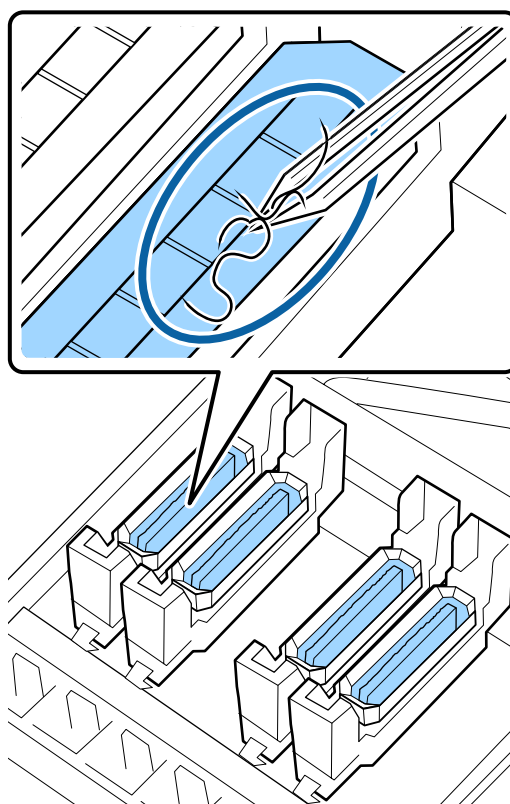

If no other parts need to be cleaned, proceed to the following section.

 [“Finishing Cleaning” on page 71](#)

**When there is lint attached to the flushing pad**

Wipe off lint and dust with the tip of a cleaning stick.



**Important:**

*Do not deform the metal section of the top surface. If they are deformed, they may damage the print head.*

Maintenance

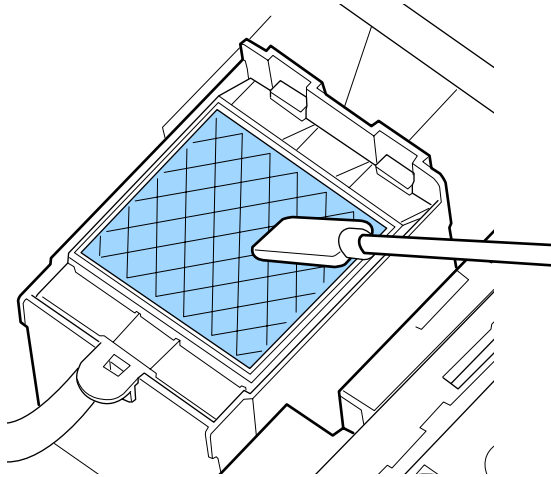

If no other parts need to be cleaned, proceed to the following section.

[“Finishing Cleaning” on page 71](#)

## Finishing Cleaning

After cleaning, close the right maintenance cover and press the OK button.

The menus will close when the print head returns to its normal position.

To continuously make prints, perform Nozzle Check.

[“Printing nozzle check patterns” on page 86](#)

Disposing of used ink cleaner, cleaning stick, and clean-room wipers [“Disposal of used consumables” on page 84](#)

## Shaking and Replacing Ink Cartridges (SC-S80600 Series/SC-S60600 Series/SC-S40600 Series)

### Shaking

#### Timing and frequency of shaking

**! Important:**

*Due to ink characteristics, the ink cartridges of this printer are prone to sedimentation (components settling to the bottom of the liquid). If ink settles, tint unevenness and nozzle clogs occur.*

*Shake a new ink cartridge before installing it. After installing it in the printer, remove and shake it periodically.*

- ❑ When replacing  
Remove the new cartridge from the package, and shake thoroughly.  
The number of shakes depends on the ink color.

OR, WH, MS	Approx. 50 times in 15 seconds
Colors other than OR, WH, MS	Approx. 15 times in 5 seconds

- ❑ Before the start of daily print work (WH/MS only)  
WH and MS tend to settle more than other colors. Before the start of daily print work, remove the ink cartridge, and then shake it the number of times listed below.

Approx. 15 times in 5 seconds
-------------------------------

If a cartridge has not been shaken for 24 hours or more, the following message appears. If the message appears, remove the ink cartridge immediately, and then shake it.

**Remove and shake MS/WH ink cartridge(s).**

## Maintenance

- Once every three weeks (All colors excluding WH/MS)  
Even after installing an ink cartridge in the printer, remove and shake it periodically.

Approx. 15 times in 5 seconds

### Shaking method

- 1 Make sure the printer is on, and then remove the ink cartridge.

When replacing a cartridge, remove the new one from the bag.

- 2 Hold the cartridge horizontally and shake it in both directions about 5 cm approx. 15 times in 5 seconds.

In the case of OR, WH, or MS, shake it well approx. 50 times in 15 seconds during replacement only.

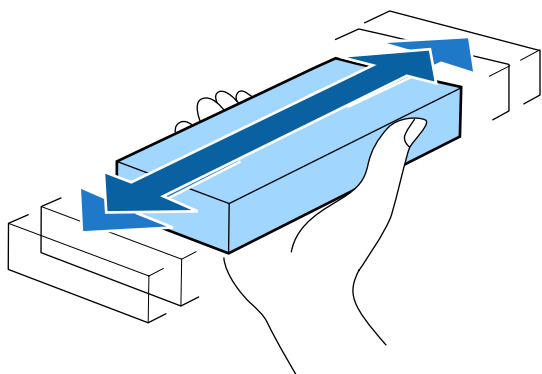

### Replacement procedure

If one of the installed ink cartridges is expended, printing cannot be performed.

**Important:**

When the message **✖ Ink Cartridge Expended** appears with use of WH/MS ink, replace the cartridge with a new one immediately.

If the printer is left with the ink remaining alert displayed, a print head or other part may be damaged.

If an ink cartridge is expended while printing, you can continue printing after replacing the ink cartridge.

If you continue to use ink cartridges that are running low, you may need to replace the ink cartridge while printing. If you replace the ink cartridge while printing, colors may look different depending on how the ink dries. If you want to avoid issues such as this, we recommend replacing the cartridge before printing. You can still use the removed ink cartridge in the future until the ink cartridge is expended.

The following procedure explains how to replace ink cartridges and Cleaning Cartridge.

**Important:**

*Epson recommends the use of genuine Epson ink cartridges. Epson cannot guarantee the quality or reliability of non-genuine ink. The use of non-genuine ink may cause damage that is not covered by Epson's warranties, and under certain circumstances, may cause erratic printer behavior. Information about non-genuine ink levels may not be displayed, and use of non-genuine ink is recorded for possible use in service support.*

- 1 Make sure the printer is on.
- 2 Lift the lock lever for the cartridge you intend to replace.

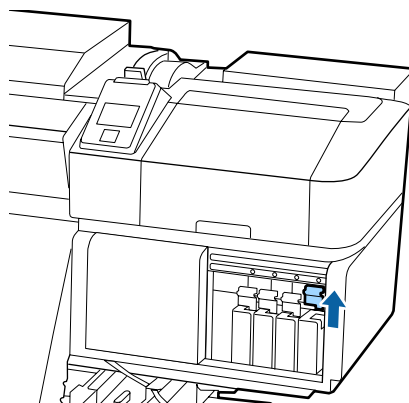



### Maintenance

- 3** Insert a finger into the depression on the top of the cartridge and pull the cartridge straight toward you.

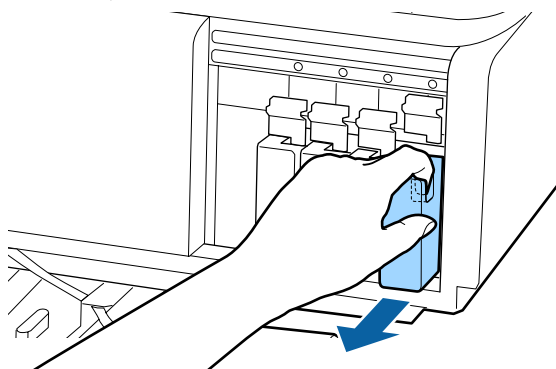

**! Important:**

Removed ink cartridges may have ink around the ink supply port, so be careful not to get any ink on the surrounding area when removing the cartridges.

- 4** Hold the cartridge horizontally and shake it in both directions about 5 cm 15 times in 5 seconds.

In the case of OR, WH, or MS, shake it well approx. 50 times in 15 seconds.

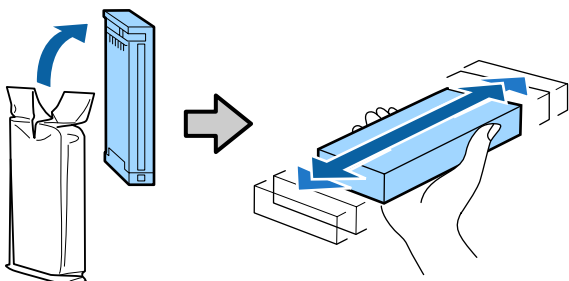

- 5** Match the color of the cartridge to the color of the label on the printer and insert.

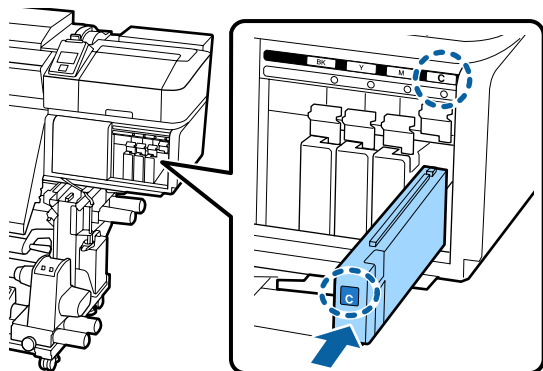

- 6** Lower the lock lever to engage the latch.

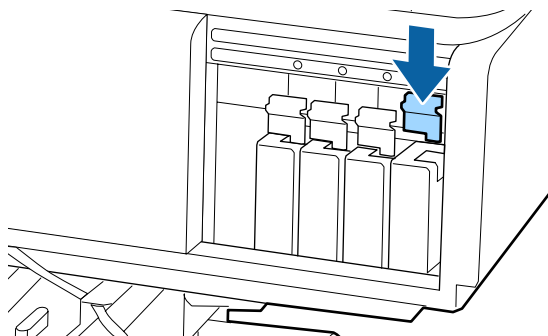

Repeat Steps 2 to 6 to replace other ink cartridges.

**! Important:**

Install all ink cartridges into each slot. You cannot print if any of the slots are empty.

Disposal [“Disposal of used consumables” on page 84](#)

Maintenance

# Shaking and Replacing Ink Supply Units (SC-S80600L Series/SC-S60600L Series)

## Shaking

### Timing and frequency of shaking

**Important:**

Due to ink characteristics, the ink supply units of this printer are prone to sedimentation (components settling to the bottom of the liquid). If ink settles, tint unevenness and nozzle clogs occur.

Shake a new ink supply unit before installing it. After installing it in the ink unit, remove and shake it periodically.

- When replacing  
The number of shakes depends on the ink color.

OR, WH, MS	Approx. 25 times in 25 seconds
Colors other than OR, WH, MS	Approx. 5 times in 5 seconds

- Before the start of daily print work (WH/MS only)  
WH and MS tend to settle more than other colors. Before the start of daily print work, remove the ink supply units, and then shake them the number of times listed below.

Approx. 5 times in 5 seconds

If they are not shaken for 24 hours or more, the following message appears. If the message appears, remove the tray immediately, and then shake it.  
**Remove and shake (MS/WH) ink supply unit(s).**

- Once every three weeks (each color excluding WH/MS)  
Remove any tray whose LED lamp is flashing blue, and then shake the tray. To maintain print quality, do not continue using them when they are flashing blue.

Approx. 5 times in 5 seconds

## Shaking method

- 1 Make sure the printer is on, and then pull the tray that needs to be shaken out of the ink unit.

Any ink supply unit whose LED lamp is flashing blue needs to be shaken.

**Important:**

Place your hand on the bottom of the tray while removing it. If you use only one hand, the weight of the tray may cause it to fall, and be damaged, as you remove it.

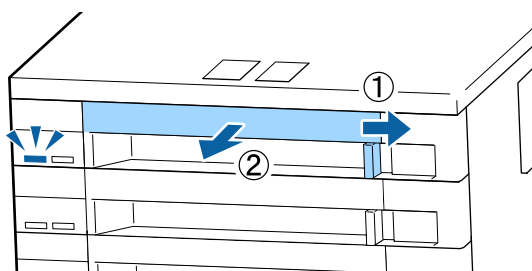

**Note:**

While the tray is pulled out, check the ink supply ports of the ink supply units. If ink has dripped from the port as shown in the photo or accumulated below, wipe it off using a cleaning stick.



Do not touch the ink supply ports while wiping.



## Maintenance

- 2** While the ink supply unit is in the tray, as shown in the illustration below, carefully shake it by tilting it up and down at about a 60 degree angle 5 times in 5 seconds.

In the case of OR, WH, or MS, shake it well approx. 25 times in 25 seconds during replacement only.

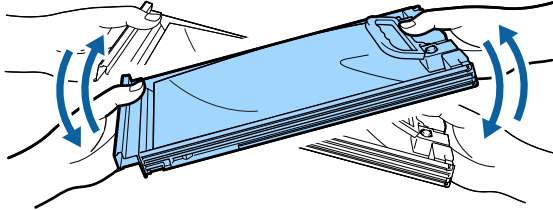

**! Important:**

Do not forcefully shake or swing ink supply units or trays holding an ink supply unit. Ink could leak.

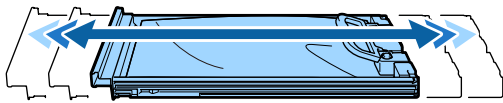

## Replacement procedure

If one of the installed ink supply units is expended, printing cannot be performed.

**! Important:**

When using WH/MS ink, immediately replace the ink supply unit with a new one if **Ink Expended** appears.

If the printer is left with the ink remaining alert displayed, a print head or other part may be damaged.

If ink is expended while printing, you can continue printing after replacing the ink supply unit. If you continue to use an ink supply unit that is running low, you may need to replace the ink supply unit while printing. If you replace it while printing, colors may look different depending on how the ink dries. If you want to avoid issues such as this, we recommend replacing the supply unit before printing. You can still use the removed ink supply unit in the future until the ink supply unit is expended.

The following procedure explains how to replace ink supply units and cleaning ink supply unit.

**! Important:**

*Epson recommends the use of genuine Epson ink supply units. Epson cannot guarantee the quality or reliability of non-genuine ink. The use of non-genuine ink may cause damage that is not covered by Epson's warranties, and under certain circumstances, may cause erratic printer behavior. Information about non-genuine ink levels may not be displayed, and use of non-genuine ink is recorded for possible use in service support.*

- 1** Make sure the printer is on.
- 2** Pull the tray of the ink supply unit you want to replace out of the ink unit.

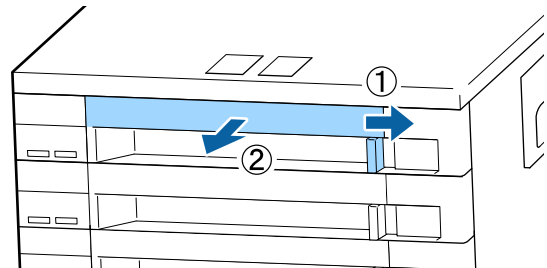

**Maintenance**

**3** Remove the ink supply unit from the tray.

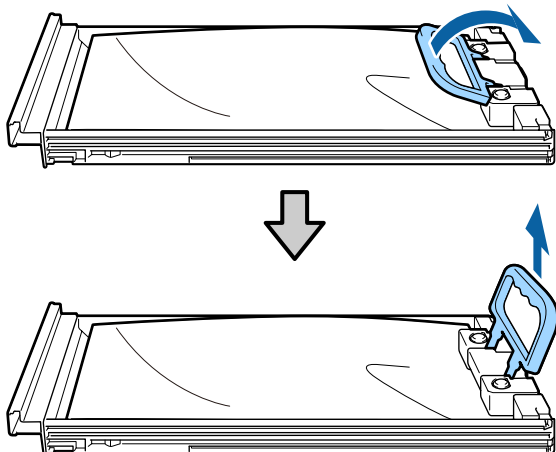

**! Important:**

*Removed ink supply units may have ink around the ink supply port, so be careful not to get any ink on the surrounding area when removing the ink supply units.*

**4** Place the new ink supply unit into the tray and lower the handle.

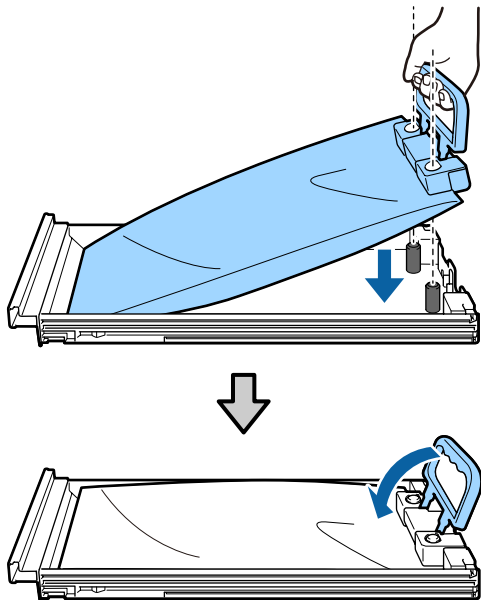

**5** While the ink supply unit is in the tray, as shown in the illustration below, carefully shake it by tilting it up and down at about a 60 degree angle 5 times in 5 seconds.

In the case of OR, WH, or MS, shake it well approx. 25 times in 25 seconds.

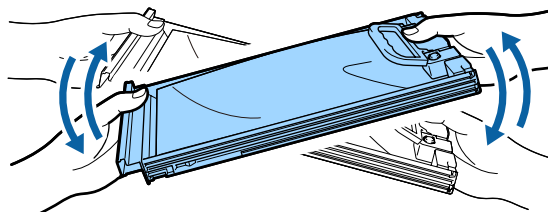

**6** Match the color on the label on the ink supply unit with the label on the ink unit, and then fully insert the tray.

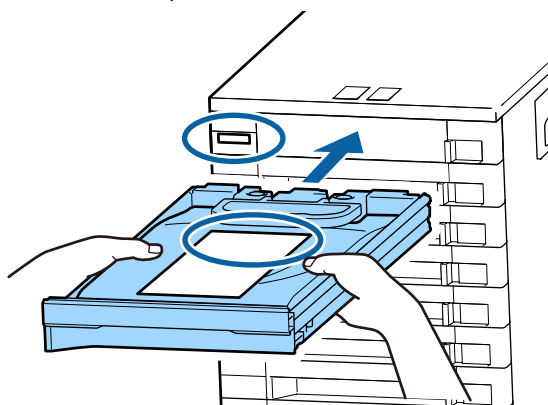

**7** Move the lock switch to the left to lock it.

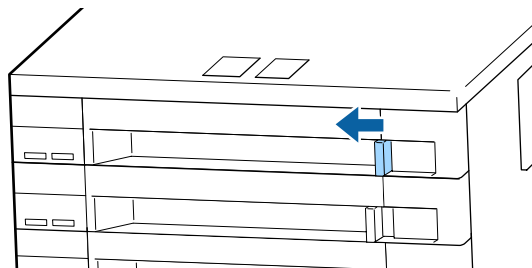

Repeat steps 2 to 7 to replace other ink supply units.

**! Important:**

*Place ink supply units in all the trays, and then insert them into the ink unit. Printing is not possible if, for even one color, an ink supply unit is not loaded into a tray or a tray is not inserted into the ink unit.*

Disposal "Disposal" on page 84

## Maintenance

# Disposing of Waste Ink

## Preparing and Replacement Timing

### Prepare empty waste ink bottle. is displayed

Prepare a new Waste Ink Bottle as soon as possible.

When you want to replace the Waste Ink Bottle at this stage due to night operations and so on, select **Replace Ink Bottle** from the setup menu, and then replace the bottle. If you perform the replacement without selecting **Replace Ink Bottle**, the waste ink counter will not operate correctly.

Maintenance menu  [“The Maintenance Menu” on page 111](#)

Waste Ink Counter  [“Waste Ink Counter” on page 77](#)

#### **Important:**

*During printing or while the printer is running the operations shown below, do not remove the Waste Ink Bottle unless instructed to do so by the on-screen instructions. Failure to observe this precaution could cause ink to leak.*

- Head Cleaning
- Head Washing
- Ink Refresh
- Pre-Storage Maint.

### Replace waste ink bottle and press **OK**. is displayed

Replace the Waste Ink Bottle with a new bottle immediately.

Replacement procedure  [“Replacing the Waste Ink Bottle” on page 77](#)

## Waste Ink Counter

The printer uses the waste ink counter to track waste ink and displays a message when the counter reaches the warning level. **Replace waste ink bottle and press **OK****. and replace the Waste Ink Bottle with a new one, the counter is cleared automatically.

If you need to replace the waste ink bottle before the message is displayed, select **Replace Ink Bottle** from the setup menu.

Maintenance menu  [“The Maintenance Menu” on page 111](#)

#### **Important:**

*If you replace the Waste Ink Bottle before being prompted by a message, always clear the waste ink counter. Otherwise, the replacement interval for the Waste Ink Bottle will no longer be notified correctly from the next message.*

## Replacing the Waste Ink Bottle

Follow the procedure below to replace the parts.

Before starting this procedure, be sure to read the following:

 [“Precautions regarding maintenance” on page 63](#)

**Maintenance**

**1** Remove the Waste Ink Bottle from the Waste Ink Bottle holder.

**SC-S80600 Series/SC-S60600 Series/  
SC-S40600 Series**

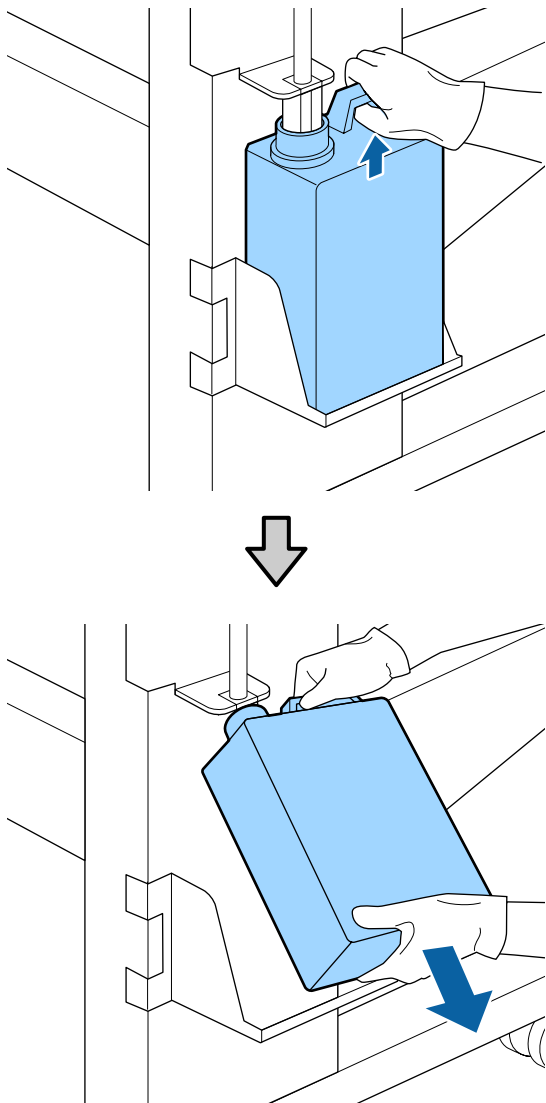

**SC-S80600L Series/SC-S60600L Series**

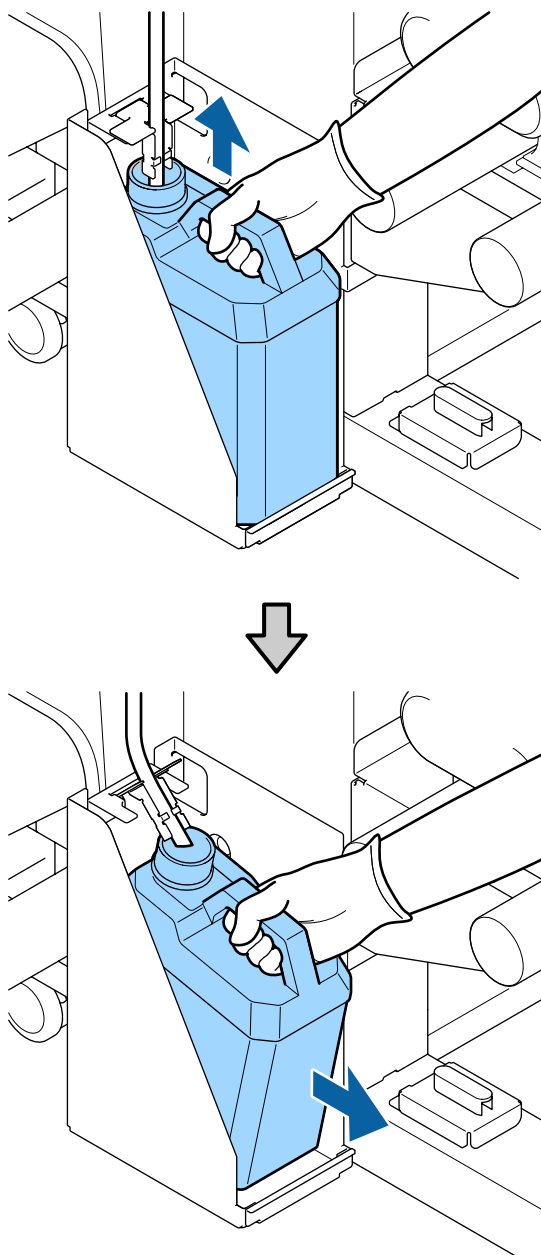

**2** Insert the waste ink tube into the mouth of the new Waste Ink Bottle and place the Waste Ink Bottle in the holder.

Tightly seal the lid on the used Waste Ink Bottle.

**! Important:**

*You will need the lid for the Waste Ink Bottle when disposing of waste ink. Keep the lid in a safe place; do not throw it out.*

**3** Press the OK button.

## Maintenance

- 4** Check again to confirm that a fresh Waste Ink Bottle is correctly placed and then press the OK button to reset the waste ink counter.

**! Important:**

*Be sure to confirm that the waste ink tube is inserted in the mouth of the waste ink bottle. Ink will spill onto the surrounding area if the tube is not inserted in the bottle.*

Leave the waste ink in the Waste Ink Bottle for disposal; do not transfer it to another container.

**Note:**

*Note the following points when transferring waste ink from the Waste Ink Bottle to another container.*

- Use a container made of PE (polyethylene) when transferring the waste ink.
- Attach the spout included with the printer to the rim of the Waste Ink Bottle and transfer the waste ink.
- Pour the waste ink carefully. Pouring the waste ink quickly may cause it to spill and splatter.
- Securely close the lid of the container to which you transferred the waste ink and store it in a location that is not exposed to open flames.

Disposing of used waste ink and Waste Ink Bottle [↗](#) “Disposal” on page 84

## Replacing Maintenance Parts

### Preparing and Replacement Timing

**When "Maintenance parts are nearing end of life." is displayed**

Prepare a new Maintenance Parts Kit as soon as possible.

When you want to replace the parts at this stage due to night operations and so on, select **Replace Parts** from the setup menu, and then replace the parts. If you perform the replacement without selecting **Replace Parts**, the maintenance parts counter will not operate correctly.

Maintenance menu [↗](#) “The Maintenance Menu” on page 111

**! Important:**

**Maintenance Counter**

*The printer tracks amounts consumed using the maintenance counter and displays a message when the counter reaches the warning level.*

*If you replace parts when the message "**Replace Parts**" is displayed, the counter is cleared automatically.*

*If you need to replace the parts before the message is displayed, select **Replace Parts** from the setup menu.*

Maintenance menu [↗](#) “The Maintenance Menu” on page 111

**When "**Replace Parts**" is displayed**

Replace all parts supplied with the Maintenance Parts Kit. Printing cannot be performed if the parts are not replaced.

Make sure you use the Maintenance Parts Kit for this printer.

[↗](#) “Options and Consumable Products” on page 124

The Maintenance Parts Kit contains the following parts. Make sure you replace all of the maintenance parts at the same time.

- Wiper unit (x1)
- Flushing pad (x1)
- Air filters (x2)

Before starting this procedure, be sure to read the following:

[↗](#) “Precautions regarding maintenance” on page 63

## Maintenance

### Replacing Maintenance Parts

- 1 When the message is displayed, press the OK button.
- 2 After the print head moves to the left end of the printer, open the right maintenance cover.

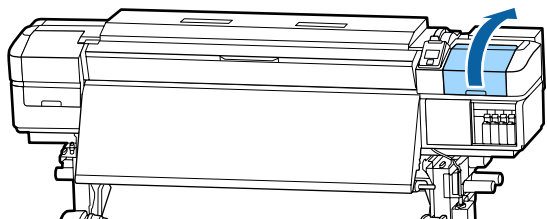

- 3 Place your fingers in the groove on the back of the wiper unit, and tilt it forward a little.

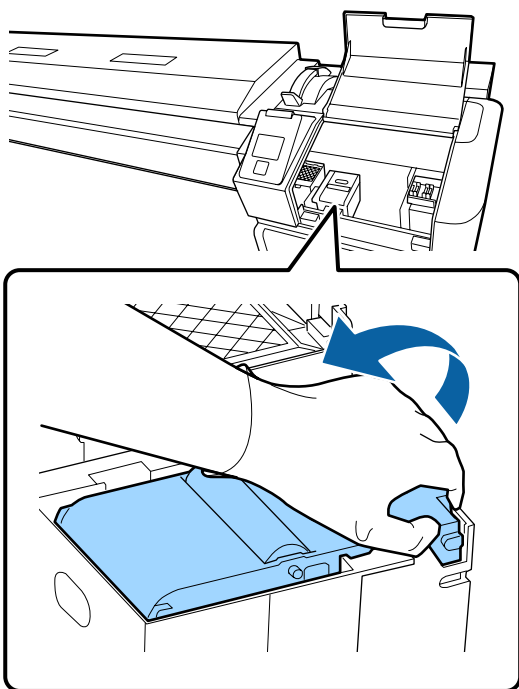

- 4 Grip the sides, and pull it straight up to lift it out.

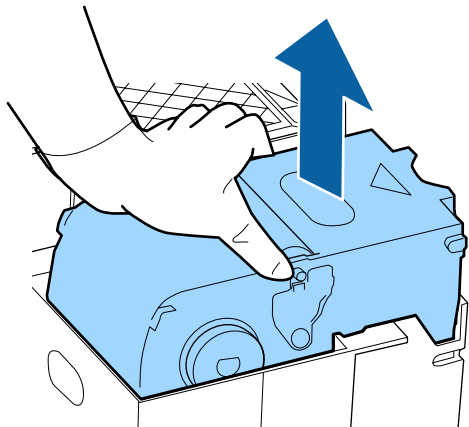

- 5 To avoid soiling your surroundings with ink, wrap the used wiper unit in the packaging supplied with the new wiper unit.

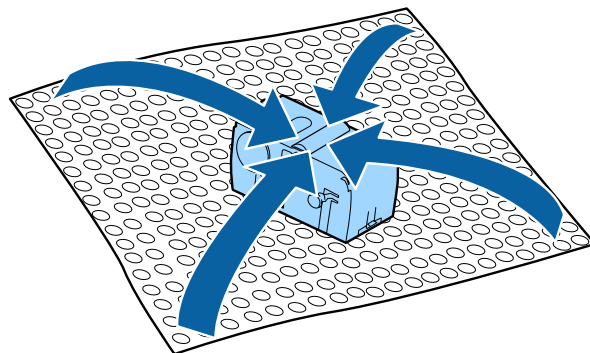

- 6 Insert the new wiper unit. Place on the attachment point and press down until you hear a click.

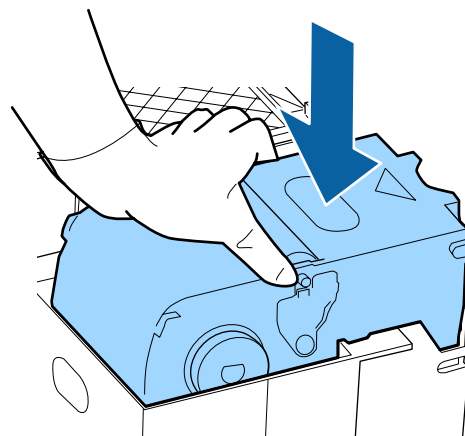

- 7 After replacing the wiper unit, press the OK button.



**Maintenance**

- 8** Lift up the tab on the flushing pad, and remove it.  
Place the removed flushing pad on the metal tray so that ink does not adhere to the surroundings.

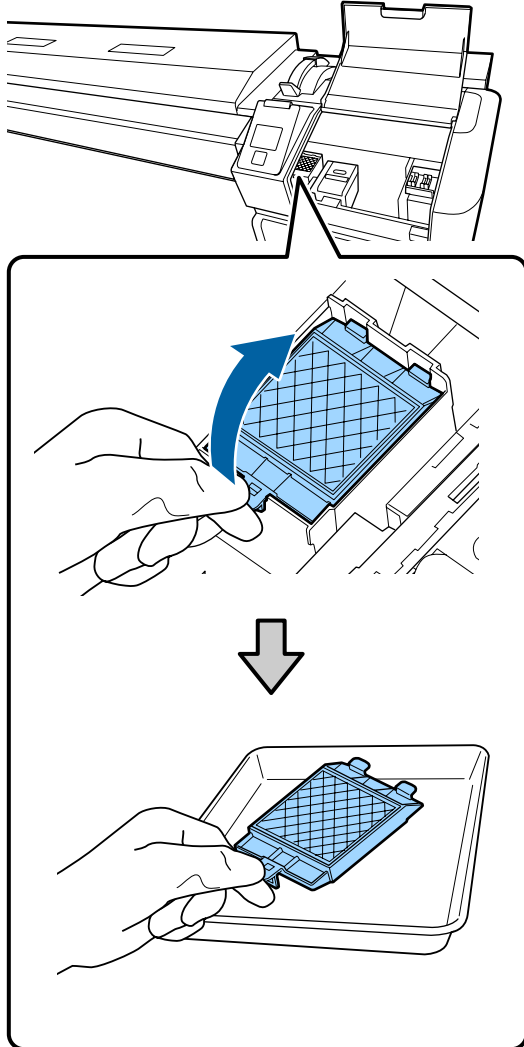

**!** **Important:**  
Leave the used flushing pad that has been removed on the metal tray until it is disposed of. If such a part is directly placed on the printer, it may leave stains that may be difficult to remove due to the characteristics of the ink.

- 9** Insert the two hooks on the flushing pad into the slots on the printer and press the tab down until the pad clicks into place.

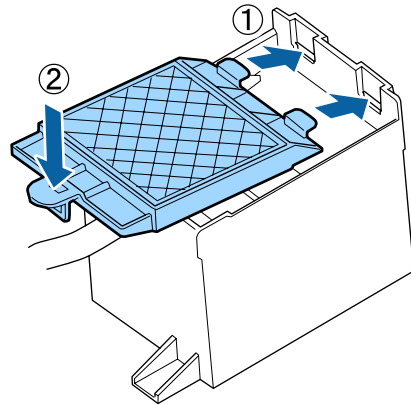

- 10** After replacing the flushing pad, press the OK button.  
**11** Remove both of the new air filters from the packaging.  
**12** Grip the air filters and lift them straight out. Replace both of the air filters.

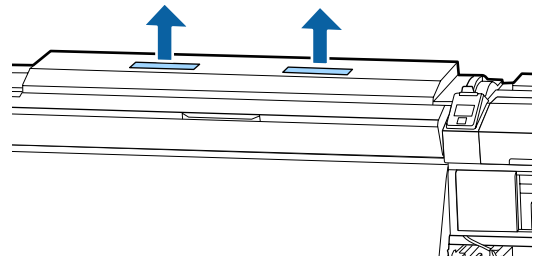

- 13** Place the removed air filters in the packaging that contained the new air filters.

- 14** Insert the new air filters.

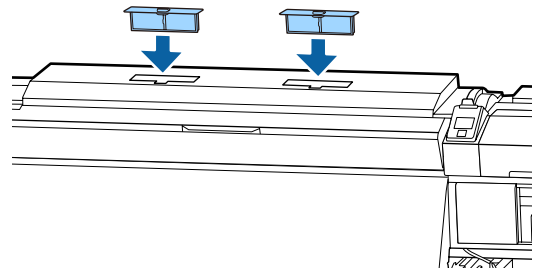

## Maintenance

- 15** Check that the air filters are installed, and then press the OK button.

**! Important:**

*Make sure you install the air filters.*

*If the printer is used when the air filters are not installed, sensors may degrade due to mist causing misalignment in print and the printer may malfunction.*

- 16** Close the maintenance cover, and then press the OK button.

- 17** A confirmation message is displayed on the screen. Check the content of the message, select **Yes**, and then press the OK button.

Disposing of used maintenance parts ➤ [“Disposal” on page 84](#)

## Replacing the media edge plates

When the media edge plates supplied with the printer are deformed or damaged, be sure to replace them with new ones.

media edge plates available on the printer

➤ [“Options and Consumable Products” on page 124](#)

**! Important:**

*If a deformed or damaged media edge plate continues to be used, it may result in damage to the print head.*

### Replacement procedure

- 1** Remove media, and turn off the printer. Check that the screen display has turned off, and then unplug the power cable from the outlet.

➤ [“Removing the Take-up Roll” on page 51](#)

Disconnect both of the power cables.

If the additional print drying system is installed, make sure you unplug the power cable for the additional print drying system as well.

- 2** Leave the printer for a minute, and then open the left maintenance cover and the front cover.

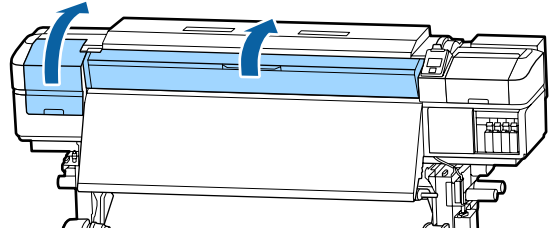

- 3** While holding the tabs of the media edge plate on both sides, move the plate to the left edge of the platen to remove it.

When replacing the right media edge plate, remove the left side first, and then remove the right.

**! Important:**

*Be sure to remove the media edge plate from the left edge of the platen. If the plate is removed from the right edge, it will drop into the printer and cause malfunction.*

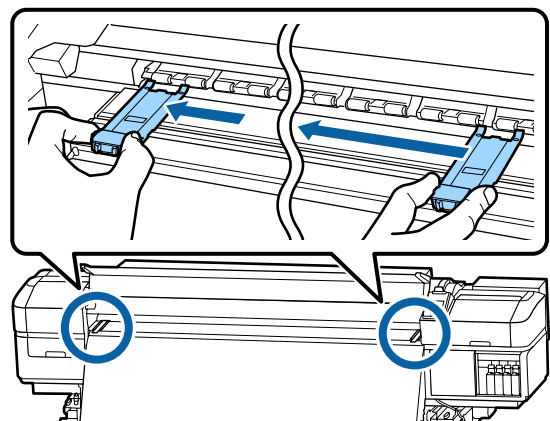

**Maintenance**

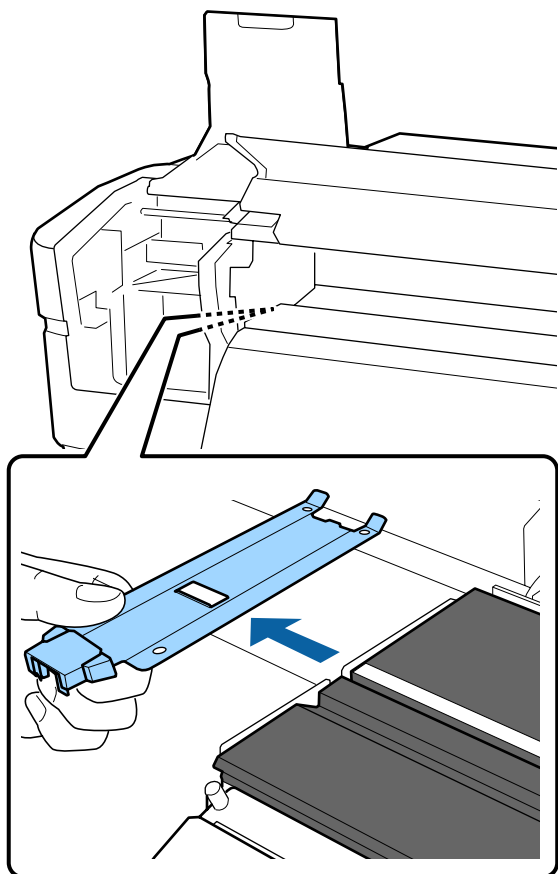

**4** Insert a new media edge plate into the left edge of the platen.

**!** **Important:**  
 You cannot attach the media edge plates from the right.

When inserting the plate, check the following two points.

(1) Align the white line on the platen with that of the media edge plate.

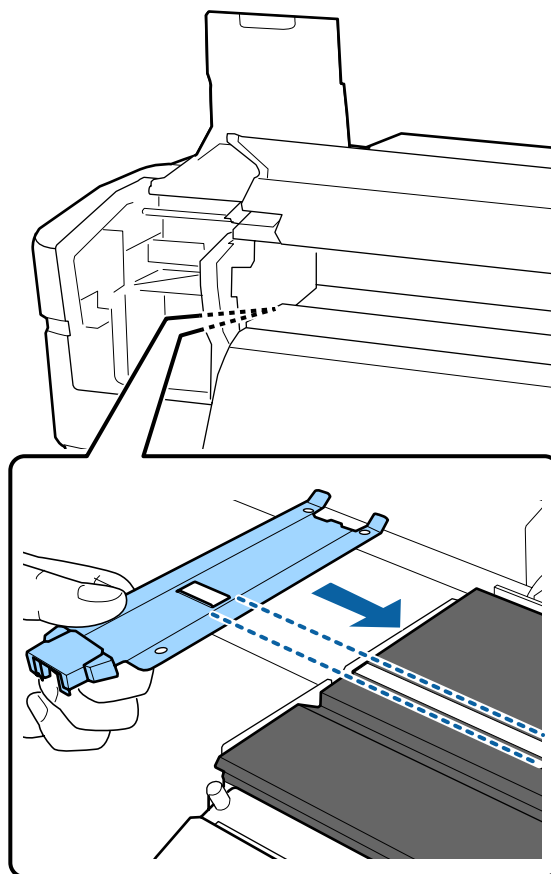

(2) While pressing the tip of the metallic plate against the platen, attach the hooked sections to the front corner of the platen.

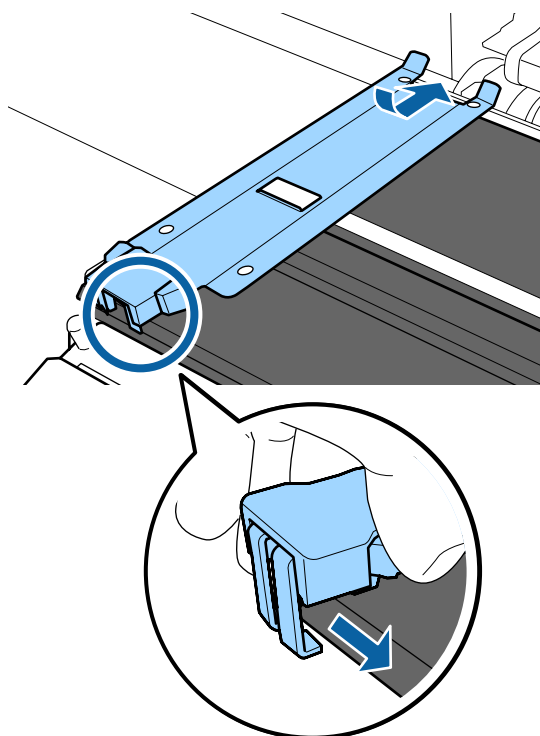

**Maintenance**

**5** Check that three hooked sections at the rear of the media edge plate are securely applied as shown below and that they are attached with no gap between the platen and media edge plate.

- ① Hook into the tip: Corners of the platen
- ② Hook into the rear of square hole: Groove in front of white line
- ③ Hook into the rear of tab: Front corner of the platen

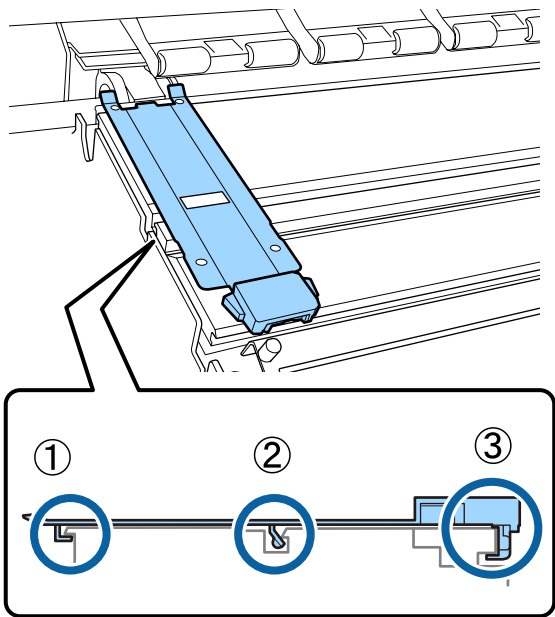

**! Important:**  
 If hooked sections are not positioned correctly, return to Step 3 to attach them again. Otherwise, the head may be damaged.

**6** While holding the tabs of each media edge plate on both sides, move both the plates to the left and right edges of the platen respectively.

Releasing the tab fixes the media edge plate.

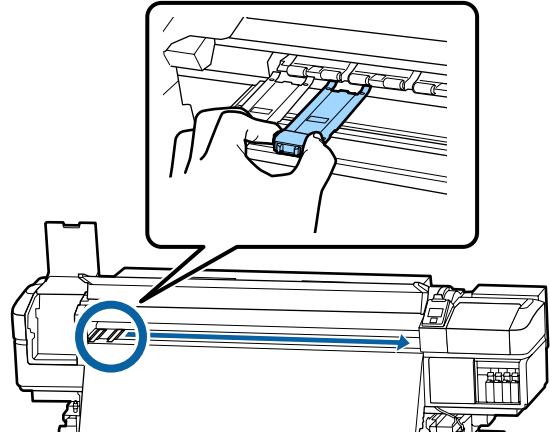

**7** Close the left maintenance cover and front cover.

## Disposal of used consumables

### Disposal

The following used parts with adhered ink are classified as industrial waste.

- Cleaning stick
- Clean-room wiper
- ink cleaner
- Waste ink
- Waste Ink Bottle
- Wiper unit
- Flushing pad
- Air filter
- Media after printing
- Empty ink supply unit

## Maintenance

Dispose of items according to local laws and regulations. For example, contract a industrial waste disposal company for disposal. In such cases, submit the "Safety data sheet" to the industrial waste disposal company.

You can download it at your local Epson Web site.

## Checking for clogged nozzles

We recommend that you check the nozzles for clogs each time you print to ensure quality results.

### Ways to Check for Clogs

There are three ways to check for clogs.

#### On-Demand Nozzle Pattern

When you want to check that there is no clogging or stripes and unevenness in print results before printing, print a nozzle check pattern. Inspect the printed check pattern visually to determine whether the nozzles are clogged.

See the following for details.

 ["Printing nozzle check patterns" on page 86](#)

Depending on the width of the loaded media, you can save media by printing additional test patterns in the space beside an existing pattern:

- If the width is equal to or greater than 51 inches but less than 64 inches, up to three patterns can be printed (one on the left, one in the center, and one on the right).
- If the width is equal to or greater than 34 inches but less than 51 inches, up to two patterns can be printed (one on the left and one on the right).
- Patterns cannot be printed side-by-side if the media is less than 34 inches wide or if **Media Size Check** is set to **OFF**.

#### Btw Pages Nozzle Check - Auto Nozzle Check

This function is useful when making prints continuously while automatically checking nozzles.

When printing for the set number of pages is complete, the printed check pattern is read by the sensor to confirm that there is no clogging.

If no clogging is detected, printing continues.

If clogging is detected, head cleaning is automatically performed and another check pattern is printed to confirm that there is no clogging. If clogging is not cleared even after performing this operation twice, a message asking if you want to continue printing is displayed.

 ["The Printer Setup Menu" on page 108](#)

#### Note:

*Auto Nozzle Check is not available under the following conditions: Print nozzle check patterns, and visually check nozzles for clogging.*

- The media is transparent or colored.*
- 2.5 is selected for **Platen Gap** in the setup menu.*
- The printer is exposed to direct sunlight or interference from other ambient light sources. In such a case, shade the printer from these sources.*
- WH/MS sections for SC-S80600 Series/SC-S80600L Series (for 10 color mode)  
The auto nozzle check can be used to check colors except for WH/MS. However, when printing WH/MS, we recommend printing a check pattern to check nozzles.*

#### Btw Pages Nozzle Check - Print Pattern

Use this function to check nozzles if you are using media not suited to **Auto Nozzle Check** or if you feel that **Auto Nozzle Check** would take too long.

When printing for the set number of pages is complete, the next page is printed across the printed check pattern. When all printing is complete, you can visually inspect the pattern to determine whether there may be faint or missing colors in the preceding or following printout.

 ["The Printer Setup Menu" on page 108](#)

Maintenance

## Printing nozzle check patterns

Buttons that are used in the following settings

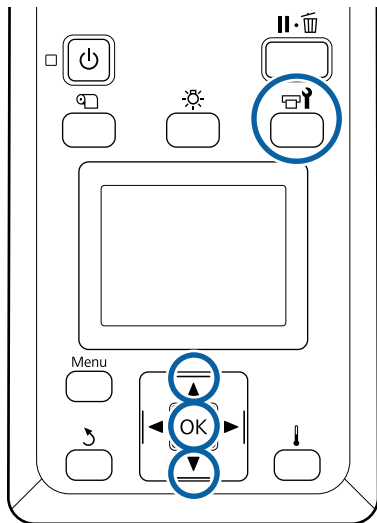

- 1 After confirming that the printer is ready, press the button.  
The Maintenance menu will be displayed.
- 2 Select **Nozzle Check**, choose a position, and press the OK button.  
A nozzle pattern will be printed.
- 3 Cut the media as necessary, and then check the printed patterns.

**Example of clean nozzles**

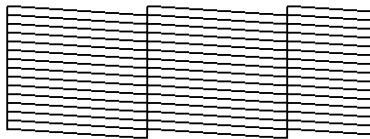

The pattern contains no gaps.

**Example of clogged nozzles**

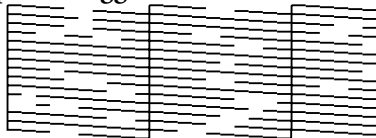

Perform head cleaning if any segments are missing from the pattern.

[“Head Cleaning” on page 86](#)

**Important:**

Always remove clogs from the nozzles of all colors before resuming use. If clogged nozzles (including clogged nozzles for colors that are not used) remain when printing after resuming use, the clogs can no longer be removed.

- 4 The menus close when printing is complete.

## Head Cleaning

### Types of Head Cleaning

Head cleaning is split between the following two types.

**Perform head cleaning as necessary.**

Print a check pattern again and check for faint or missing segments to confirm if there is any clogging after performing head cleaning.

You can perform head cleaning while printing by pausing the job. Note, however, that color tones in the printout may change when printing is resumed.

See the following for details.

[“Head cleaning procedure” on page 87](#)

**Auto Maintenance Options**

To prevent nozzles from regularly clogging, the printer features two handy auto maintenance options for performing regular head cleaning.

- Periodical Cleaning**  
Although you can set a print distance and number of pages at which time head cleaning is performed, it is also performed automatically at a suitable time according to the media settings.  
Periodical Cleaning [“Customize Settings” on page 104](#)
- Btw Pages Nozzle Check - Auto Nozzle Check**  
When printing for the set number of pages is complete, the printed check pattern is read by the sensor to confirm that there is no clogging. If clogging is detected, head cleaning is automatically performed and another check pattern is printed to confirm that there is no clogging. If no clogging is detected, printing continues. If clogging is not

## Maintenance

cleared even after performing this operation twice, a message asking if you want to continue printing is displayed.

☞ “The Printer Setup Menu” on page 108

### Head cleaning procedure

Buttons that are used in the following settings

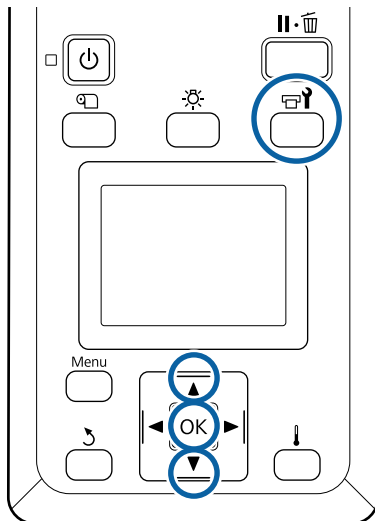

- 1 After confirming that the printer is ready, press the button.

The Maintenance menu will be displayed.

To clean while printing, press the button.

- 2 Use the to select **Cleaning** and press the OK button.

- 3 Select a cleaning level, and then press the OK button.

There are three levels available for head cleaning.

Perform **Cleaning (Light)** first. After cleaning, print a check pattern and if there are still faint or missing segments, perform **Cleaning (Medium)**. If this still does not solve the problem, perform **Cleaning (Heavy)**.

- 4 Select the cleaning method you want to use for each row of nozzles.

When **Cleaning (Light)** is selected, only **All Nozzles** is available.

#### All Nozzles

Choose this option if all patterns in the printed nozzle check results contain faint or missing segments. After making your selections, proceed to Step 6.

#### Head1/Head2

This is displayed by the SC-S80600 Series/SC-S80600L Series/SC-S60600 Series/SC-S60600L Series only.

Select this if there are faint or missing segments in only one of the print heads. After making your selections, proceed to Step 6.

#### Selected Nozzles

Select this if there are faint or missing segments in only some of the numbered patterns (nozzle arrays) in the check pattern. You can select multiple nozzle arrays.

- 5 Choose the nozzle arrays to be cleaned.

(1) Use the to choose the nozzle arrays with faint or missing segments in the pattern, and then press the OK button.

(2) After selecting the arrays you want to clean, select **Execute With Selection**, and then press the OK button.

- 6 Head cleaning starts.

A confirmation message is displayed when cleaning is complete.

If you paused the printer in Step 1, printing will resume when head cleaning is complete; check the printout to confirm whether the problem has been resolved.

- 7 To print a check pattern and check the status of the clog, use the to select **Nozzle Check**, and then press the OK button.

When printing a check pattern in the margin of media on which a check pattern has already been printed, press the to move the print start position to the pressure rollers position.

When you select **Exit** and press the OK menu, the setup menu closes.

#### Nozzles are still clogged after performing head cleaning several times

The areas around the print heads may be soiled.

Perform the following.

## Maintenance

- (1) Perform **Auto Head Maintenance** from the setup menu.

 [“The Maintenance Menu” on page 111](#)

If clogging is not cleared after performing (1), perform (2).

- (2) Perform regular cleaning.

 [“Performing Regular Cleaning” on page 65](#)

If clogging is not cleared after performing (2), perform (3).

- (3) Perform **Head Washing** from the setup menu.

 [“The Maintenance Menu” on page 111](#)

## Long-term Storage (Pre-storage Maintenance)

### Pre-storage Maintenance Timing

Always perform Pre-storage Maintenance if the printer will not be used (and will be turned off) for a long time.

If you do not print for a long time and do not perform pre-storage maintenance, turn the printer on at least once every seven days.

 **Important:**

*If you do not perform Pre-storage Maintenance, a print head nozzle could become permanently clogged.*

As shown below, the necessity of Pre-storage Maintenance depends on your model.

#### SC-S40600 Series/SC-S60600 Series/SC-S60600L Series

For pre-storage maintenance, use the number of the cleaning cartridges/cleaning ink supply units (CL) (sold separately) shown for each model in the following table.

Interval	Number of CLs
1 month or more	SC-S40600 Series: 4 SC-S60600 Series: 8 SC-S60600L Series: 8

#### SC-S80600 Series/SC-S80600L Series

Due to the characteristics of WH/MS ink, it can be left for about six days.

When ink has not been used for 13 days or less, perform Pre-storage Maintenance for WH/MS ink only.

When the time span is two weeks or longer, Pre-storage Maintenance must be performed for all colors. For pre-storage maintenance, use the number of the cleaning cartridges/cleaning ink supply units (CL) (sold separately) shown for each model in the following table.

For 10 color mode

Interval	Target color	Number of CLs
7 to 13 days	WH/MS	SC-S80600 Series: 2 SC-S80600L Series: 2
2 weeks or more	All colors (All Nozzles)	SC-S80600 Series: 10 SC-S80600L Series: 10

For 9 color mode

Interval	Target color	Number of CLs
2 weeks or more	All colors (All Nozzles)	SC-S80600 Series: 10 SC-S80600L Series: 10

 **Important:**

*If you want to perform **Pre-Storage Maint.** for **All Nozzles**, when it was already done only for WH/MS, switch on the power of the printer, fill the WH/MS ink, and then perform **Pre-Storage Maint.** again.*



## Maintenance

### Performing Pre-storage Maintenance

#### **Important:**

*If the amount of remaining ink or cleaning fluid is insufficient, the function may not run. If there is an insufficient amount of ink remaining, have new ink cartridges/ink supply units on hand as a precaution.*

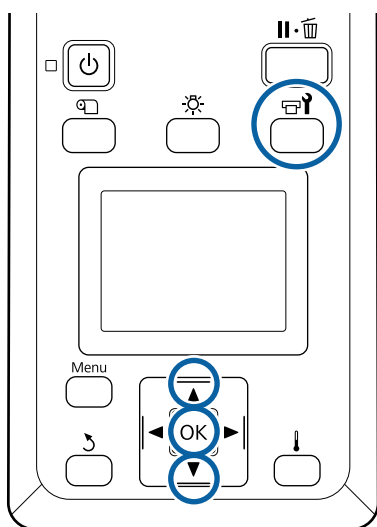

Buttons that are used in the following settings



- 1 After confirming that the printer is ready, press the  button.

The Maintenance menu will be displayed.

- 2 Use the  button to select **Other maintenance**, and then press the OK button.

- 3 Use the / buttons to select **Pre-Storage Maint.**, and press the OK button.

- 4 Select **All Nozzles**, and then press the OK button.

For SC-S80600 Series/SC-S80600L Series (10 color mode), if you will not use the printer for less than 13 days, select **WH** or **MS**, depending on which ink is installed, and then press the OK button.

- 5 Then follow the on-screen instructions to replace the ink cartridge/ink supply unit.

Before storing them, clean off any ink stuck on ink supply ports of ink cartridges/ink supply units, which you removed.

#### **Cleaning method**

Lightly touch the corner of a cleaning stick from the supplied Maintenance Kit to the hole of the ink supply port to adsorb the ink, as shown in the illustration below. You do not need to wipe off the ink.

Use a new cleaning stick for each color to avoid mixing the colors. Do not forcefully press or move the cleaning stick.

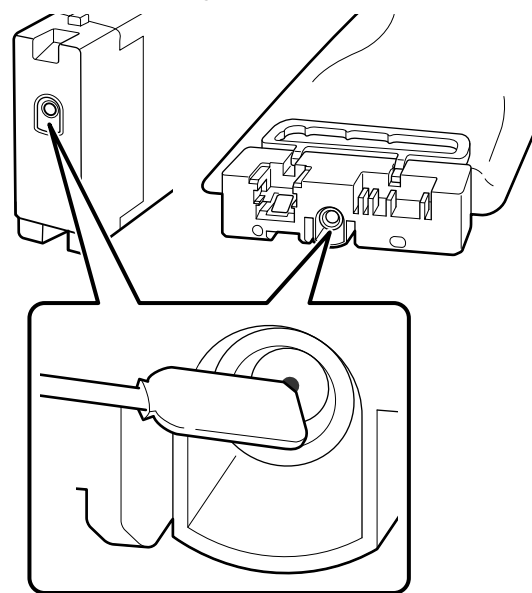

Observe the following cautions when storing the printer and ink cartridges/ink supply units that were removed during use.

 [“Notes when not using the printer” on page 21](#)

 [“Notes on handling ink cartridges/ink supply units” on page 22](#)

### Restarting use of the printer

#### **Important:**

*When restarting use of the printer, charge the printer with ink. When charging with removed ink cartridges/ink supply units, have new ink cartridges/ink supply units on hand as a precaution.*

## Maintenance

Switch on the power and follow the on-screen instructions.

When first printing after restarting use, perform a nozzle check and check that there are no clogs.

 "Printing nozzle check patterns" on page 86

# Change Color Mode (SC-S80600 Series/ SC-S80600L Series only)

Change the color mode as follows on the printer as necessary.

- 10 color mode (WH) <=> 10 color mode (MS)
- 10 color mode (WH) <=> 9 color mode
- 10 color mode (MS) <=> 9 color mode

## Notes on Changing

The time required and preparation for Change Color Mode are shown below.

### Time required: up to approximately 1 hour

The time required to complete the change varies according to the current color mode.

### What you need:

- When changing the spot color to use (WH <=> MS)  
Ink cartridge/ink supply unit of the color to which you changed 1  
Cleaning cartridge/cleaning ink supply unit 1

**Note:**



*When changing the spot color, eject ink from the tubes and wash them using a cleaning liquid to avoid mixing colors, and then switch to the new spot color.*

- For 9 color mode  
Cleaning cartridge/cleaning ink supply unit 1

- For 10 color mode  
Ink cartridge/ink supply unit of the color to be used 1

 **Important:**

*If the installed cleaning cartridges/cleaning ink supply units or OR/WH/MS ink cartridges/ink supply units are running low on ink, you may not be able to change the ink.*

- You can change the ink immediately after  appears for the remaining ink levels for the ink cartridges/ink supply units; however, you cannot change the ink if there is an  **Ink Expended** error.
- If there is an insufficient amount of ink remaining, have new ink cartridges/ink supply units on hand as a precaution.

## Timing when Changing from 10 to 9 Colors

If you do not print using WH/MS inks during the period shown in the table below, switch to 9 color mode to avoid consuming WH/MS inks.

As well as printing, the printer also consumes ink during auto ink circulation.

When the printer is not used for approximately three months\* or more.

\* The standard period is indicated, assuming the following usage conditions.

- The power always remains turned on.
- Monthly number of operating days: 20

 **Important:**

*If the period in which the spot color inks are not used is shorter than the specified periods in the table, we do not recommend that you change the color mode because ink consumption increases when the color mode is changed.*

## Maintenance

### Change Color Mode procedure

Buttons that are used in the following settings

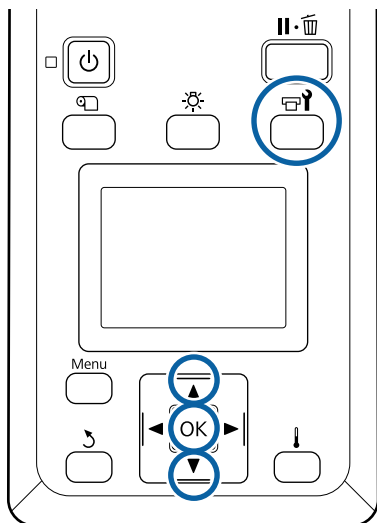

- 1 After confirming that the printer is ready, press the button.  
The Maintenance menu will be displayed.
- 2 Use the button to select **Other maintenance**, and then press the OK button.
- 3 Use the / buttons to select **Change Color Mode**, and press the OK button.
- 4 Use the / buttons to select any mode, and press the OK button.

Then follow the on-screen instructions to replace the ink cartridge/ink supply unit.

Observe the following cautions when storing the ink cartridges/ink supply units that were removed during use.

[“Notes on handling ink cartridges/ink supply units” on page 22](#)

### Cleaning inside the front cover

Ink mist causes the inside of the front cover to become dirty. If you continue to use the printer while this is dirty, you cannot see inside the printer.

If it is dirty, follow the steps below to clean.

- 1 Make sure the printer is turned off and the screen has turned off, and then unplug the power cable from the outlet.  
  
Disconnect both of the power cables.  
  
If the additional print drying system is installed, make sure you unplug the power cable for the additional print drying system as well.
- 2 Leave the printer for a minute.
- 3 Open the front cover.
- 4 Wipe lint and dust adhered to the inside of the front cover using a soft cloth that has been soaked in water and squeezed well.

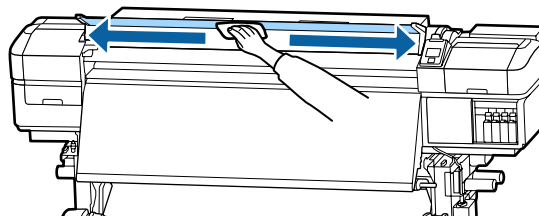

For anything that cannot be removed with a damp cloth, dip a cloth in neutral detergent, squeeze it out, and then wipe the stubborn stain.

### Cleaning pressure rollers

If you keep using the pressure rollers when they are soiled with ink mist, the print outs will be soiled.

If the rollers are dirty, follow the steps below to clean them.

## Maintenance

- 1 Make sure the printer is turned off and the screen has turned off, and then unplug the power cable from the outlet.  
Disconnect both of the power cables.  
If the additional print drying system is installed, make sure you unplug the power cable for the additional print drying system as well.
- 2 Leave the printer for a minute.
- 3 Open the front cover.
- 4 Raise the media loading lever.
- 5 Wrap a soft cloth that has been soaked in water and squeezed well around the tip of your finger as shown in the illustration.

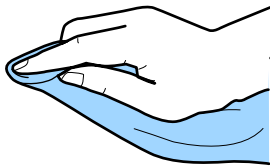

- 6 Use the cloth to wipe the sides of the pressure rollers that have become soiled.

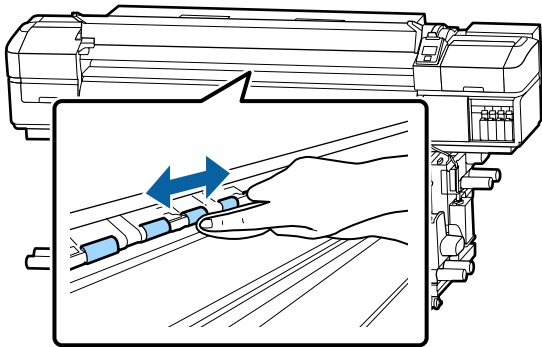

### **!** Important:

When wiping, make sure the cloth or your finger does not touch the rod B shown in the illustration.

If the cloth or your finger touch the rod, an error could occur during printing.

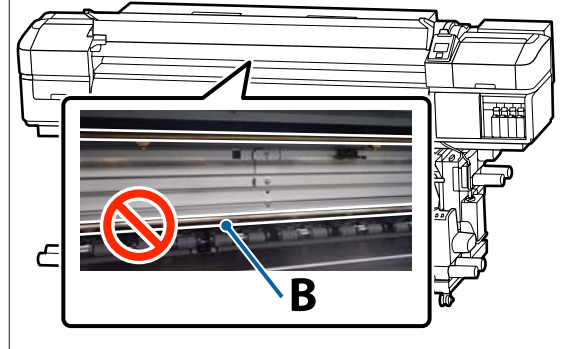

## Applying Grease to the Carriage Rod

When Apply secondary carriage rod grease. See **manual**. is displayed on the control panel screen, follow the steps below to apply grease to the carriage rod as soon as possible.

### Location of Carriage Rod and Used Pad

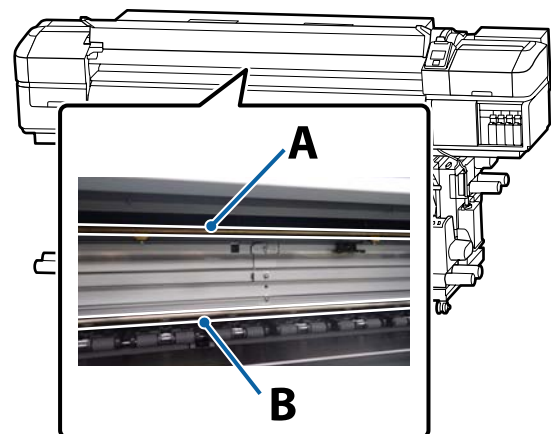

There are two carriage rods, rod A and rod B. Apply grease to both rods using the grease kit supplied with the printer.

The grease application tool varies depending on the rod as shown below.

## Maintenance

### Carriage rod A

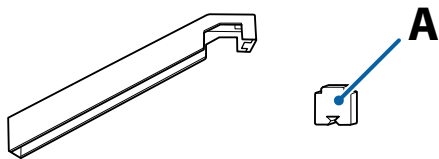

### Carriage rod B

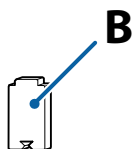

Before starting this procedure, be sure to read the following:

"Precautions regarding maintenance" on page 63

## Greasing procedure for carriage rod A

Buttons that are used in the following settings

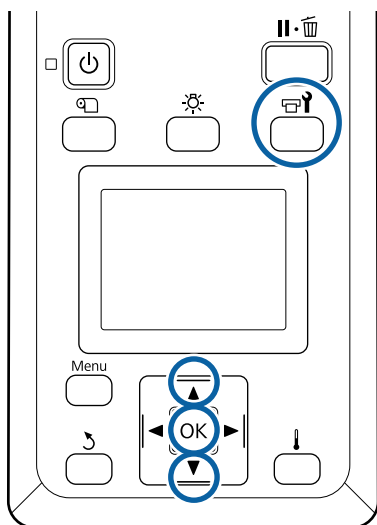

- 1 After confirming that the printer is ready, press the button.  
The Maintenance menu will be displayed.
- 2 Use the button to select **Other maintenance**, and then press the OK button.

- 3 Use the button to select **Grease Carriage Rod**, and then press the OK button.

When **Grease kit is needed. Continue?** is displayed. Make sure that you have a grease kit ready to use.

- 4 Use the button to select **Yes**, and then press the OK button.

- 5 Insert the tab of the pad A (new) firmly into the rectangular slot on the grease tool and fit the pad to the tool as shown.

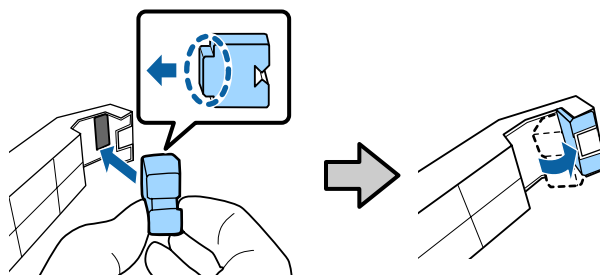

- 6 Open the front cover.

- 7 Hold the pad of the tool firmly against the back of the carriage rod A, and then slide it smoothly from the right end to the left end to wipe off stains on the rod.

Repeat this action four times.

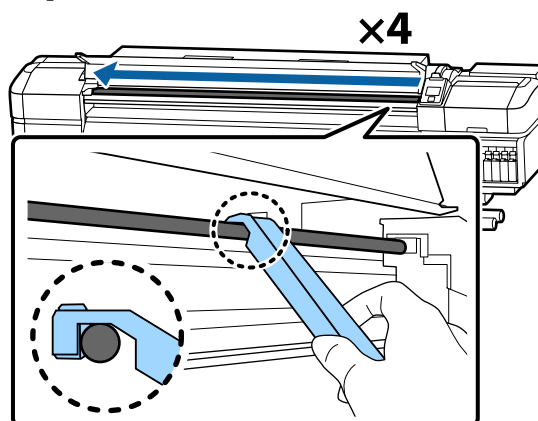

**Maintenance**

**! Important:**  
 Do not slide the tool back and forth.  
 If you slide the tool back and forth, dust will be moved to the print head stand-by position and a malfunction may occur.

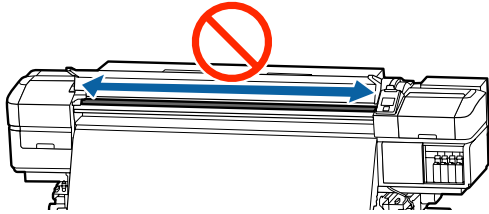

- 8** Remove the dirty pad from the tool.
- 9** Attach a new pad A to the grease tool.
- 10** Using a new cleaning stick, stir the grease in the container about ten times.
- 11** Wipe the tip of the cleaning stick on the edge of the container to remove excess grease.

**! Important:**  
 Failure to remove the excess could result in falling grease dirtying the platen and media.

- 12** Using a cleaning stick, apply grease to the pad you attached to the tool as described below.
  - (1) Insert the tip of the cleaning stick fully into the container, and twist it 2 to 3 times to get enough grease on the stick.
  - (2) Apply grease to the pad on the tool.

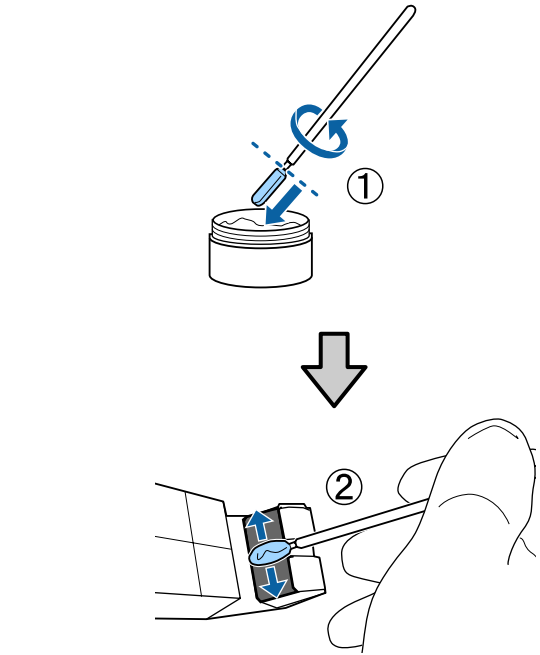

- 13** Hold the pad of the tool as described in step 7, and slide the grease tool back and forth twice.

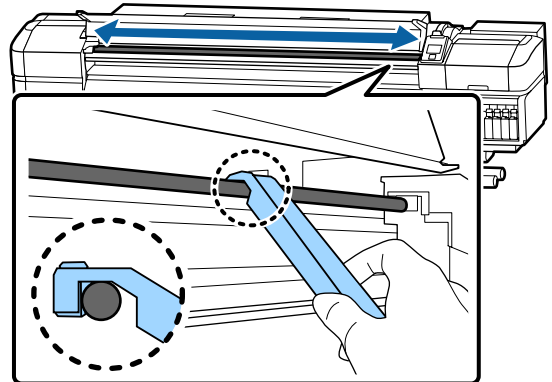

Next, apply grease to carriage rod B.

Maintenance

## Greasing procedure for carriage rod B

- 1 Hold a new pad B firmly against the gray part of the rod as shown in the illustration, and smoothly slide it from the right end to the left end to wipe off stains on the rod.

Repeat this action four times.

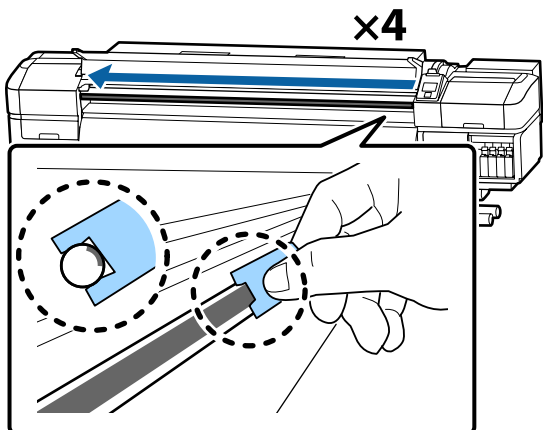

**! Important:**

Do not slide pad B back and forth.

If you slide the tool back and forth, dust will be moved to the print head stand-by position and a malfunction may occur.

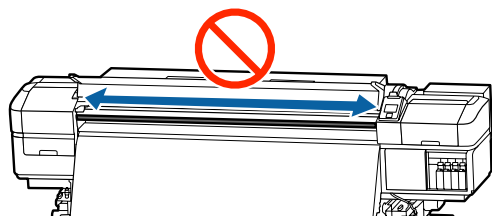

- 2 Apply grease to the new pad B as described below.

Replace pad B used in step 1. These should not be reused.

- (1) Insert the tip of the cleaning stick fully into the container, and twist it 2 to 3 times to get enough grease on the stick.

- (2) Apply grease to new pad B.

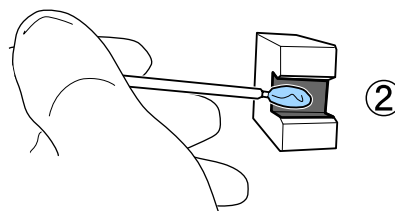
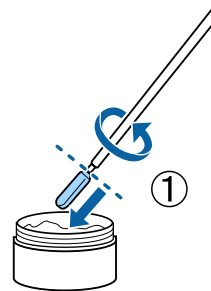

- 3 Hold pad B as described in step 1, and slide the pad back and forth twice.

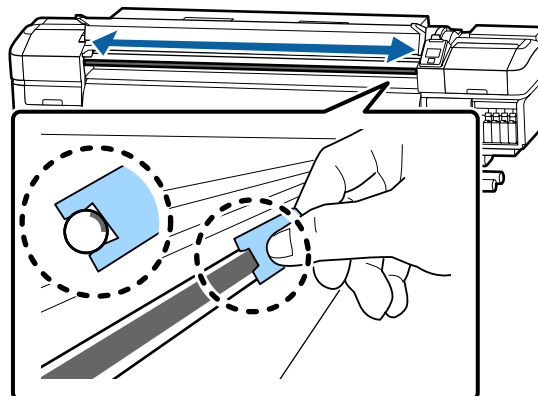

- 4 Close the front cover, and then press the OK button.

The carriage moves back and forth.

- 5 Remove the stained pad from the grease tool, and then store the grease tool with the grease.

Disposing of used pads, cleaning sticks, and other items used to apply grease

[“Disposal of used consumables” on page 84](#)

## Storing Grease

- Replace the cap to prevent foreign objects falling into the grease.

## Maintenance

- ❑ Store the container at room temperature with the cap uppermost in a location that is not exposed to direct sunlight.

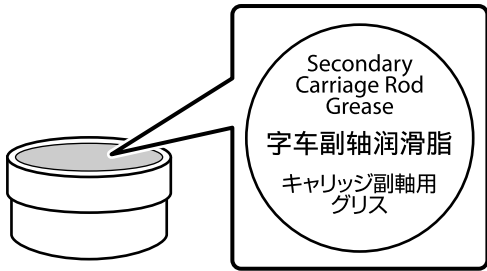



Using the Control Panel Menu

# Using the Control Panel Menu

## Menu Operations

The menus are used as shown below.

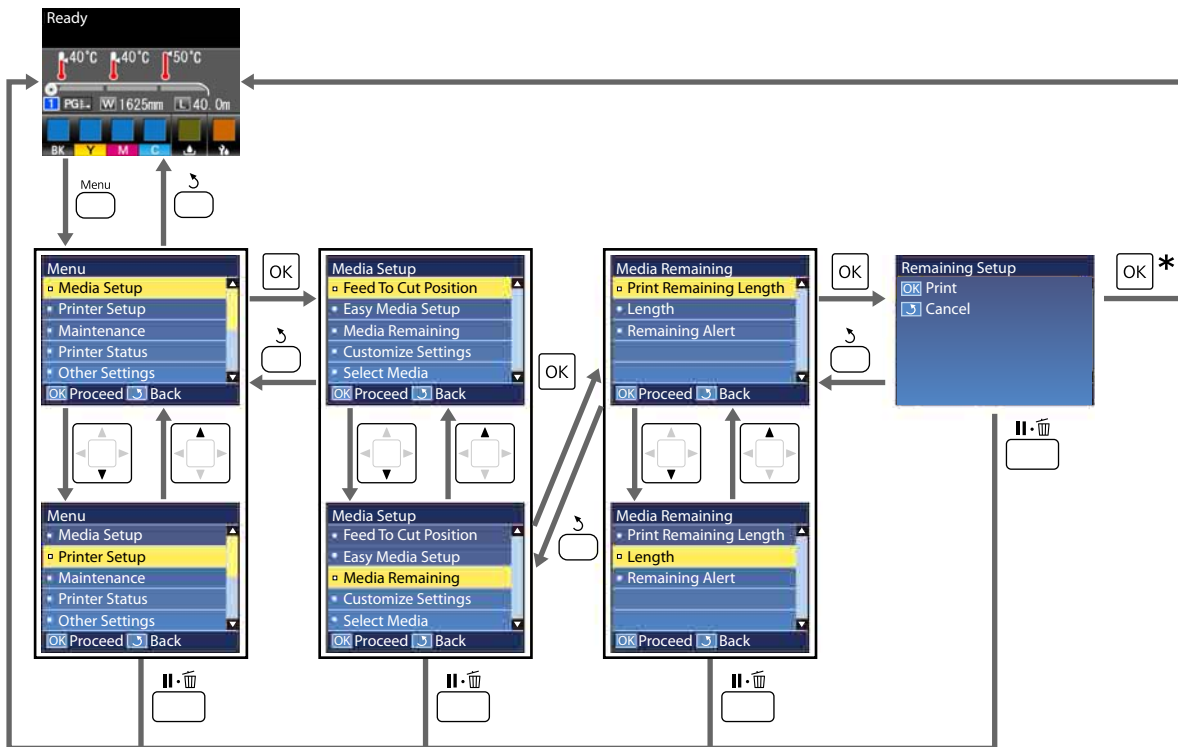

\* When printing or adjusting after selecting an item and pressing the OK button, the status display screen is displayed when the process is complete.

Normally, when you select an item and press the OK button, the choice is confirmed and you are returned to the previous screen.

## Using the Control Panel Menu

# Menu List

The following items and parameters can be set and executed in the Menu. See the reference pages for more details on each item.

### Media Setup

For more information on these items, see  [“The Media Setup Menu” on page 104.](#)

\*1: For SC-S80600L Series/SC-S60600L Series only

Item	Parameter
Feed To Cut Position	Sends the end of the print to the cutter groove
Easy Media Setup	Registers new media settings easily
Media Remaining	
Print Remaining Length	Print
Length	OFF, 1.0 to 100.0 m
Remaining Alert	1 to 15 m
Customize Settings	

### Using the Control Panel Menu

Item	Parameter
Current Settings	
1 to 30 (media setting number)	
Setting Name	Up to 22 half-size characters
Media Type	Adhesive Vinyl, Banner, Film, Canvas, Textile, Paper/Other
Media Adjust	
Auto	Print
Manual	
Feed Adjustment	Standard, 500mm Pattern
Head Alignment	Print
Advanced Settings	
Platen Gap	1.6, 2.0, 2.5
Heating & Drying	
Heater Temperature	Pre-heater/platen heater: OFF, 30 to 50°C After heater: OFF, 30 to 55°C
Drying Time Per Pass	0 to 10 sec
After Heater Feed	Mode 1, Mode 2, OFF
Additional Dryer	ON, OFF
Media Tension	Lv1, Lv2, Lv3, Lv4
Media Suction	0 to 10

### Using the Control Panel Menu

Item		Parameter
	Head Movement	Data Width, Printer Full Width
	Multi Strike Printing	OFF, 2 to 8
	Feed Speed Limiter	ON, OFF
	Pressure Roller Load	Low, Medium, Heavy
	Remove Skew	ON, OFF
	Take-Up* <sup>1</sup>	Standard, strength tension
	Periodical Cleaning	
	Auto	
	Manual	
	Length	
	Enter Value	1 to 100
	When To Clean	Between Pages, Middle Of Page
	Cleaning Level	Low, Medium, Heavy
	Page	
	Between Pages	1 to 100
	Cleaning Level	Low, Medium, Heavy
	Restore Settings	Yes, No
	Select Media	1 to 30 (media setting number)

#### Printer Setup

For more information on these items, see  [“The Printer Setup Menu” on page 108](#)

Setting items and setting values marked with asterisks indicate the following printer models.

\*1: For SC-S80600 Series/SC-S80600L Series/SC-S60600 Series/SC-S60600L Series only

Item		Parameter
Margin Setting		
	Side Margin(Right)	3 to 25 mm
	Side Margin(Left)	3 to 25 mm
	Print Start Position	0 to 800 mm
Media Check		
	Media Size Check	ON, OFF
	Media End Check	ON, OFF
	Media Skew Check	ON, OFF

## Using the Control Panel Menu

Item	Parameter
Media End Option	Continue, Stop Printing
Btw Pages Nozzle Check	
OFF	-
Print Pattern	1 to 10
Auto Nozzle Check	1 to 10
Lamp Setting	Auto, Manual
Head Mode* <sup>1</sup>	2 Heads Mode, Head1, Head2
Sleep Mode	15 to 240 minutes
Restore Settings	Yes, No

### Maintenance

For more information on these items, see  [“The Maintenance Menu” on page 111](#)

Setting items and setting values marked with asterisks indicate the following printer models.

\*1: for SC-S80600 Series/SC-S80600L Series/SC-S60600 Series/SC-S60600L Series only, \*2: for SC-S80600 Series/SC-S80600L Series only, \*3: for SC-S60600 Series/SC-S60600L Series only

Item	Parameter
Nozzle Check	Print
Print At Right	(The options available vary with the option selected for <b>Media Size Check</b> and the width of the media used.)
Print At Center	
Print At Left	
Cleaning	
Cleaning (Light)	All Nozzles
Cleaning (Medium)	All Nozzles, Head1* <sup>1</sup> , Head2* <sup>1</sup> , Selected Nozzles
Cleaning (Heavy)	
Head Maintenance	
Auto Head Maintenance	Execute
Regular Cleaning	Move Head
Replace Ink Bottle	-
Replace Parts	-
Other maintenance	

### Using the Control Panel Menu

Item	Parameter
Ink Circulation* <sup>2</sup>	Execute
Ink Refresh* <sup>2</sup>	Execute
Head Washing	XX/XX, Head1 XX/XX* <sup>3</sup> , Head2 XX/XX* <sup>3</sup> , Head1 All Nozzles* <sup>3</sup> , Head2 All Nozzles* <sup>3</sup> , All Nozzles ("XX" indicates an ink color code.)
Pre-Storage Maint.	WH* <sup>2</sup> , MS* <sup>2</sup> , All Nozzles
Change Color Mode* <sup>2</sup>	9 Color, 10 Color (WH), 10 Color (MS)
Grease Carriage Rod	Yes, No

#### Printer Status

Details on menu  [“The Printer Status Menu” on page 114](#)

\*1: For SC-S80600 Series/SC-S60600 Series/SC-S40600 Series only

Item	Parameter
Level	
Ink	Display current status
Waste ink bottle	
Wiper Unit	
Print Status Sheet* <sup>1</sup>	Print
Firmware Version	XXXXXXXX,X_XX,XXXX

#### Preferences

Details on menu  [“The Preferences Menu” on page 114](#)

\*1: For SC-S80600L Series/SC-S60600L Series only

Item	Parameter
Network Setup	
IP Address Setting	
Auto	-
Panel	IP: 000.000.000.000 – 255.255.255.255 SM: 000.000.000.000 – 255.255.255.255 DG: 000.000.000.000 – 255.255.255.255
Print Status Sheet	Print
Restore Settings	Yes, No
Preferences	

### Using the Control Panel Menu

Item	Parameter
Date And Time	MM/DD/YY HH:MM
Language	Japanese, English, French, Italian, German, Portuguese, Spanish, Dutch, Russian, Korean, Chinese
Units	
Unit: Length	m, ft/in
Unit: Temperature	°C, F
Alert Sound Setting	On, On (Continuous) <sup>*1</sup> , Off
Print Completion Sound <sup>*1</sup>	On, Off
Alert Lamp Setting	ON, OFF
Reset All Settings	Yes, No

## Using the Control Panel Menu

# Details of the Menu

## The Media Setup Menu

The Media Setup menu can be accessed directly by pressing the  button.

\* indicates default settings.

### Feed To Cut Position

Sends the end of the print to the cutting groove.

### Easy Media Setup

You can quickly and easily register media settings using the Wizard to perform optimum printing according to the size and type of the media being used.

 [“Saving New Media Settings” on page 45](#)

## Media Remaining

Item	Parameter	Explanation
Print Remaining Length	Print	Use <b>Print Remaining Length</b> to print the amount of media remaining on the current roll before replacing it with another type of media. You can then enter this number as the media the length the next time the roll is used.
Length	OFF, 1.0 to 100.0 m (30 <sup>*</sup> )	Enter a value for overall roll length between 1.0 and 100.0 m. You can set in 0.5 m increments. When you select <b>OFF</b> , the following remaining amount is not calculated. <ul style="list-style-type: none"> <li><input type="checkbox"/> Display remaining amount of media on the control panel screen</li> <li><input type="checkbox"/> Display warning message for remaining amount of media</li> </ul>
Remaining Alert	1 to 15 m (5 <sup>*</sup> )	An alert will be displayed if the amount of media remaining reaches this length. Choose from values between 1 and 15 m. You can set in 1 m increments.

## Customize Settings

Item	Explanation
Current Settings	To change the currently selected setting, select <b>Current Settings</b> . When changing specific media settings, select the setting number for the target media.
1 to 30 (media setting number)	

### Media setting item

The manufacturer settings for each item differ depending on the [Media Type] selected. See the following for details on the manufacturer settings for each media type.

 [“Media Settings List for Each Media Type” on page 135](#)



### Using the Control Panel Menu

\*1: For the SC-S80600L Series/SC-S60600L Series only

Item	Parameter	Explanation		
Setting Name		Assign the media setting bank a name up to 22 half-size characters long. Using distinctive names makes it easier to select banks for use.		
Media Type	Adhesive Vinyl	Select the media type according to the loaded media.		
	Banner	The printer stores the optimum media settings according to the media type. When the media type is changed, each setting for media registered to the current media setting number changes to the value for the media type after changing.		
	Film			
	Canvas			
	Textile			
	Paper/Other			
Media Adjust		This is used after performing adjustments once under the following conditions.		
	Auto	Print	<p><input type="checkbox"/> After Auto Media Adjust is performed, banding or graininess is found in the print results.</p> <p><input type="checkbox"/> When changing <b>Advanced Settings</b> after saving media settings.</p> <p>Adjustment types and execution procedure  <a href="#">"Optimization of media settings (Media Adjust)" on page 48</a></p> <p><b>Auto</b> is not displayed when selecting <b>Film, Canvas, Textile, or Paper/Other</b> in <b>Media Type</b>.</p>	
	Manual			
	Feed Adjustment			
		Standard		Print
		500mm Pattern		Print
		Head Alignment		Print
Advanced Settings		<p>In most situations, use the value set for each media type as it is.</p> <p>When using special media or when a problem such as head striking or banding is detected in printing results, change the default.</p>		

### Using the Control Panel Menu

Item	Parameter	Explanation
Platen Gap	1.6	Choose the platen gap (the distance between the print head and the media).
	2.0	The default setting of <b>1.6</b> is recommended in most situations. Choose 2.0 if the printout is scratched or smudged. Select 2.5 only if print results are still smudged when 2.0 is selected. Choosing a larger gap than required may result in ink stains inside the printer, reduced print quality, or shorter product life.
	2.5	
Heating & Drying		
Heater Temperature	Pre-heater/ platen heater: OFF, 30 to 50°C (40*)  After heater: OFF, 30 to 55°C (50*)	The temperatures for the pre-, platen, and after heaters can each be adjusted separately.
Drying Time Per Pass	0 to 10 secs (0*)	Select the time the print head pauses to allow drying after each pass. Choose from values between 0.0 and 10.0 seconds. The time needed for the ink to dry varies with ink density and the media used. If the ink blurs on the media, set a longer time for drying the ink.  Increasing the drying time increases the time needed to print.
After Heater Feed	Mode 1	To feed media to the after heater after printing, choose <b>Mode 1</b> or <b>Mode 2</b> ; otherwise, choose <b>OFF</b> .  If <b>Mode 1</b> is selected, the portion fed for drying will not be rewound before the next job starts. Select this option if the media will be cut before the next job starts.  If <b>Mode 2</b> is selected, the portion fed for drying will be rewound before the next job starts, eliminating unnecessary margin. Select this option if multiple jobs will be printed consecutively.  When cutting media using <b>Mode 2</b> , hold down the ▲ button to rewind the end of the print to the cutter groove, and then cut. If cut without rewinding the media, printing may not be performed correctly next time.
	Mode 2	
	OFF*	
Additional Dryer	ON*	This item is displayed only when the Additional Print Drying System (supplied with the SC-S60600 Series/SC-S60600L Series; optional with other models) is installed.  Select <b>ON</b> to enable, or <b>OFF</b> to disable, the Additional Print Drying System. Note that even when <b>ON</b> is selected, the Additional Print Drying System turns off with the heaters when they enter sleep mode. The Additional Print Drying System turns back on when the heaters resume operation. Sleep mode  <a href="#">"The Printer Setup Menu" on page 108</a>
	OFF	

## Using the Control Panel Menu

Item	Parameter	Explanation
Media Tension	Lv1	Increase tension if creases appear in the media during printing. The higher the value, the greater the tension.
	Lv2	
	Lv3	
	Lv4	
Media Suction	0 to 10 (4*)	When media is waved on the platen, increase the <b>Media Suction</b> . The higher the value, the greater the suction.  If graininess or out-of-focus characteristics are detected in printing results obtained using thin or soft media or if the media is not fed normally, reduce the <b>Media Suction</b> .
Head Movement	Data Width*	Choose the range in which the print head moves during printing.  <b>Data Width</b> restricts print head movement to the printed area. Restricting the extent of print head movement increases print speed.
	Printer Full Width	If <b>Printer Full Width</b> is selected, the print head will move the full width of the largest media supported by the printer. Select this option for more even print results with less variation.
Multi Strike Printing	OFF*	Choose the number of times each line is printed.
	2 to 8	To carry out high-density printing using backlight films, increase the frequency.
Feed Speed Limiter	ON	<b>OFF</b> is recommended in normal circumstances.
	OFF*	Set this to <b>ON</b> if media sticks or wrinkles, or tears easily when printing on thin media.  When this is set to <b>ON</b> , print speed slows down.
Pressure Roller Load	Low	If the following occurs when printing, you may be able to avoid it by changing to a load that reduces the pressure on the rollers (for example: <b>Medium</b> to <b>Low</b> ).  <input type="checkbox"/> When there is wrinkling around the pressure rollers. <input type="checkbox"/> When there are stains due to head striking. <input type="checkbox"/> When stains on the roller stick to the media.
	Medium	
	Heavy	
Remove Skew	ON	Select whether or not (ON or OFF) to perform skew correction for media loaded in the printer. The default setting of <b>ON</b> is recommended in most situations. Set this to <b>OFF</b> if the media shows traces from the rollers due to skew corrections.
	OFF	
Take-Up* <sup>1</sup>	Standard*	Normally, use as <b>Standard</b> .
	strength tension	If the media sticks while printing on media that builds up static easily and cannot be taken up correctly because of problems, such as waving, set this to <b>strength tension</b> . If the problem persists, even when setting this to <b>strength tension</b> , use media that does not build up static easily.
Periodical Cleaning		
Auto*		Performs head cleaning at the most suitable time according to the media settings.  If the specified time for periodic cleaning is reached during printing, head cleaning is performed after printing is complete.
	Manual	<b>Manual</b> is performed when specifying the frequency according to the usage.

### Using the Control Panel Menu

Item	Parameter	Explanation		
	Length		<p>Sets the frequency for periodic cleaning according to the prints performed.</p> <p><b>Enter Value</b> performs head cleaning after printing a specific number of meters.</p> <p>When To Clean sets whether or not to perform head cleaning even when the cleaning time is reached during printing.</p> <p>Cleaning Level sets the strength for head cleaning.</p>	
	Enter Value	1 to 100 (10 <sup>*</sup> )		
	When To Clean	Between Pages <sup>*</sup>		
		Middle Of Page		
	Cleaning Level	Low <sup>*</sup>		
		Medium		
		Heavy		
	Page			<p>Sets the frequency for periodic cleaning according to the number of pages printed.</p> <p>Between Pages specifies the page at which to perform head cleaning.</p> <p>Cleaning Level sets the strength for head cleaning.</p>
	Between Pages	1 to 100 (10 <sup>*</sup> )		
	Cleaning Level	Low <sup>*</sup>		
Medium				
Heavy				
Restore Settings	Yes	<p>If <b>Yes</b> is selected, the setting content of selected media settings are returned to the default settings.</p>		
	No			

### Select Media

Parameter	Explanation
1 to 30 (media setting number)	<p>Choose the media settings used for printing.</p> <p>Perform <b>Easy Media Setup</b> when you register new settings. Change setting content in <b>Customize Settings</b>.</p>

## The Printer Setup Menu

\* indicates default settings.

Setting items and setting values marked with asterisks (\*1) indicate the following printer models.

\*1: For SC-S80600 Series/SC-S80600L Series/SC-S60600 Series/SC-S60600L Series only

Item	Parameter	Explanation
Margin Setting		



### Using the Control Panel Menu

Item	Parameter	Explanation
Side Margin(Right)	3 to 25 mm (5 <sup>*</sup> )	Choose the width of the right margin when media is loaded in the printer. See the following for more information. <a href="#">☞ "Printable area" on page 57</a>
Side Margin(Left)	3 to 25 mm (5 <sup>*</sup> )	Choose the width of the left margin when media is loaded in the printer. See the following for more information. <a href="#">☞ "Printable area" on page 57</a>
Print Start Position	0 to 800 mm (0 <sup>*</sup> )	Adjust this parameter if you want to print from the near center of the media or if you want to shift the printed area left from the <b>Side Margin(Right)</b> setting. The area between the right edge of the media and <b>Print Start Position</b> is left blank. If a value is selected for <b>Side Margin(Right)</b> , an additional area corresponding to the width selected for <b>Side Margin(Right)</b> will be left blank. See the following for more information. <a href="#">☞ "Printable area" on page 57</a>
Media Check		
Media Size Check	ON <sup>*</sup>	Choose whether the printer automatically detects ( <b>ON</b> ), or does not automatically detect ( <b>OFF</b> ), the edges of the media. Try <b>OFF</b> if the printer displays a <b>Media Size Error</b> when the media is correctly loaded. Note, however, that the printer may print beyond the edges of the media when <b>OFF</b> is selected. Ink used outside the edges of the media will stain the inside of the printer. We generally recommend to operate with this setting set to <b>ON</b> .
	OFF	
Media End Check	ON <sup>*</sup>	Choose whether the printer automatically detects ( <b>ON</b> ) or does not automatically detect ( <b>OFF</b> ), the end of the media. Try <b>OFF</b> if the printer displays <b>Media Out</b> when the media is correctly loaded. We generally recommend to operate with this setting set to <b>ON</b> .
	OFF	
Media Skew Check	ON <sup>*</sup>	When skewed media is detected, the printer will either stop printing and display an error ( <b>ON</b> ) or continue printing ( <b>OFF</b> ). <b>ON</b> is recommended in most circumstances, as skewed media may cause the printer to jam.
	OFF	
Media End Option	Continue <sup>*</sup>	When replacing media while printing, select either <b>Continue</b> (print the remaining data after replacement) or <b>Stop Printing</b> (do not print).
	Stop Printing	
Btw Pages Nozzle Check		

### Using the Control Panel Menu

Item	Parameter	Explanation
OFF	-	Select how to perform periodic nozzle checks.
Print Pattern	1 to 10 (1*)	When this is set to <b>OFF</b> , a nozzle check is not performed between pages.
Auto Nozzle Check	1 to 10 (1*)	<p>For <b>Auto Nozzle Check</b>, when printing for the set number of pages is complete, the printed check pattern is read by the sensor to confirm that there is no clogging. If no clogging is detected, printing continues.</p> <p>If clogging is detected, head cleaning is automatically performed and another check pattern is printed to confirm that there is no clogging. If clogging is not cleared even after performing this operation twice, a message asking if you want to continue printing is displayed.</p> <p>Auto Nozzle Check is not available under the following conditions:</p> <ul style="list-style-type: none"> <li><input type="checkbox"/> Areas that print using WH/MS inks in SC-S80600 Series/SC-S80600L Series (10 color mode). (This can still be performed with other colors.)</li> <li><input type="checkbox"/> The media is transparent or colored.</li> <li><input type="checkbox"/> <b>2.5</b> is selected for <b>Platen Gap</b> in the setup menu.</li> <li><input type="checkbox"/> The printer is exposed to direct sunlight or interference from other ambient light sources. In such a case, shade the printer from these sources.</li> </ul> <p>For <b>Print Pattern</b>, when printing for the set number of pages is complete, the next page is printed across the printed check pattern. When all printing is complete, you can visually inspect the pattern to determine whether there may be faint or missing colors in the preceding or following printout. Use this for media not suited for <b>Auto Nozzle Check</b> or if you feel that <b>Auto Nozzle Check</b> would take too long.</p>
Lamp Setting	Auto*	Select whether to turn on/off the light inside the front cover automatically ( <b>Auto</b> ) or whether to use the panel button as necessary ( <b>Manual</b> ).
	Manual	<p>In <b>Auto</b>, the light turns on automatically when printing and so on, and turns off when the operation is complete.</p> <p>In <b>Manual</b>, you need to press the  button on the control panel to turn the light on/off. When you press the button during an operation that does not allow the light to turn on, the light turns on as soon as possible.</p>
Head Mode*1	2 Head Mode*	Use in <b>2 Head Mode</b> in most situations.
	Head1	<p>For example, if there is a clogged nozzle in a single print head and the clog cannot be cleared after repeated head cleaning, you continue printing using the unclogged print head. This feature is convenient because printing can continue during work time, and <b>Head Washing</b> and other maintenance can be done after work.</p> <p>Check the check pattern printed in the <b>Nozzle Check</b>, and then select the unclogged head.</p>
	Head2	

### Using the Control Panel Menu



Item	Parameter	Explanation
Sleep Mode	15 to 240 minutes (15*)	<p>The printer enters sleep mode when no errors are detected and no print jobs have been received for a specific time. In sleep mode, all heaters turn off, the control panel turns off, and the internal motors and other components consume less power. If an Additional Print Drying System (supplied with the SC-S60600 Series; optional with other models) is installed, it will turn off automatically.</p> <p>To reactivate the control panel display, press any button in the control panel except . The control panel display will however turn off again if no operations are performed for another 30 seconds under these conditions. The printer and heaters are only fully reactivated when a print job is received, the media loading lever is used, or another operation involving printer hardware is performed.</p> <p>To return from sleep mode and begin preheating the heater immediately, press the  button, and perform <b>Start Preheat</b>.</p>
Restore Settings	Yes	Select <b>Yes</b> to restore all items in the <b>Printer Setup</b> menu to their default settings.
	No	

## The Maintenance Menu



The Maintenance menu can be accessed directly by pressing the  button.

Setting items and setting values marked with asterisks (\*X) indicate the following.

\*1: for SC-S80600 Series/SC-S80600L Series/SC-S60600 Series/SC-S60600L Series only, \*2: for SC-S80600 Series/SC-S80600L Series only, \*3: for SC-S60600 Series/SC-S60600L Series only



Item	Parameter	Explanation
Nozzle Check	Print	<p>A nozzle pattern will be printed. Inspect the pattern visually and perform head cleaning if you detect faint or missing colors.</p> <p> <a href="#">"Printing nozzle check patterns" on page 86</a></p> <p>The options available vary with the option selected for <b>Media Size Check</b> and the width of the media used.</p>
Print At Right		
Print At Center		
Print At Left		
Cleaning		
Cleaning (Light)	All Nozzles	<p>You can set head cleaning from three levels. Perform <b>Cleaning (Light)</b> first. If clogging is not cleared by performing <b>Cleaning (Light)</b>, perform <b>Cleaning (Medium)</b>, and then <b>Cleaning (Heavy)</b> if necessary.</p> <p>When you select <b>Cleaning (Medium)</b> or <b>Cleaning (Heavy)</b>, note the numbers of patterns that contain faint or missing colors and clean all or selected nozzles with problems.</p> <p>When checking the printed pattern for the SC-S80600 Series/SC-S80600L Series/SC-S60600 Series/SC-S60600L Series, you can select to clean the specific print head that contains faint or missing colors and clean just one print head.</p> <p> <a href="#">"Head Cleaning" on page 86</a></p>
Cleaning (Medium)	All Nozzles	
Cleaning (Heavy)	Head1*1	
	Head2*1	
	Selected Nozzles	

### Using the Control Panel Menu

Item	Parameter	Explanation
Head Maintenance	Auto Head Maintenance	If the message <b>Press  and perform Head Maintenance.</b> is displayed on the control panel screen, select <b>Regular Cleaning</b> and perform cleaning.
	Regular Cleaning	<p> <a href="#">"Performing Regular Cleaning" on page 65</a></p> <p>Perform <b>Auto Head Maintenance</b> if nozzles are still clogged and ink drops form even after performing head cleaning.</p> <p> <a href="#">Operation Guide (PDF)</a></p>
Replace Ink Bottle	-	If you replace the Waste Ink Bottle before being prompted to do so by a message on the control panel, select Waste Ink Bottle.
Replace Parts	-	Perform operations from this menu when replacing maintenance parts before a message prompting you to do so is displayed.
Other maintenance		



### Using the Control Panel Menu

Item	Parameter	Explanation
Ink Circulation* <sup>2</sup>	Execute	<p>Circulates the MH/MS inks in the print head and tubes.</p> <p>When printing multiple copies as a batch, auto ink circulation is performed between pages. In this situation, colors may differ before and after circulation, and it may take some time to finish the print job. To avoid printing being paused due to auto ink circulation, execute this menu before starting printing.</p>
	Execute	<p>This function is available when tint unevenness (areas of uneven density) are detected in printing results.</p>
Ink Refresh* <sup>2</sup>	Execute	<p>This function is available when tint unevenness (areas of uneven density) are detected in printing results.</p>
	Execute	<p>This function is available when tint unevenness (areas of uneven density) are detected in printing results.</p>
Head Washing	XX/XX, Head1 XX/XX* <sup>3</sup> , Head2 XX/XX* <sup>3</sup> , Head1 All Nozzles* <sup>3</sup> , Head2 All Nozzles* <sup>3</sup> , All Nozzles ("XX" indicates an ink color code.)	<p>Use this function if nozzle clogs cannot be cleared even after performing head cleaning several times, Auto Head Maintenance, or cleaning around the print head.</p> <p>Check which colors are faint or missing in the nozzle check pattern, and follow the steps below to wash the parts.</p> <p><b>XX/XX:</b> "XX" indicates an ink color code. Select the target color when faint or missing segments of a specific color are detected.</p> <p><b>All Nozzles:</b> Select this when faint or missing segments of all colors are detected.</p> <p>You can also select the following for the SC-S80600 Series/SC-S80600L Series/SC-S60600 Series/SC-S60600L Series.</p> <p><b>Head1 XX/XX/Head2 XX/XX:</b> Select the target color for a target head when faint or missing segments of a specific color are detected.</p> <p><b>Head1 All Nozzles/Head2 All Nozzles:</b> Select this when faint or missing segments are detected for all colors on a specific print head.</p> <p>For head washing, use cleaning cartridges/cleaning ink supply units (sold separately), as described below.</p> <ul style="list-style-type: none"> <li><input type="checkbox"/> When <b>XX/XX</b> is selected: 2</li> <li><input type="checkbox"/> For <b>All Nozzles:</b> <ul style="list-style-type: none"> <li>The SC-S80600 Series/SC-S80600L Series (for 10 color mode): 10</li> <li>The SC-S80600 Series/SC-S80600L Series (for 9 color mode): 9</li> <li>SC-S60600 Series/SC-S60600L Series: 8</li> <li>SC-S40600 Series: 4</li> </ul> </li> <li><input type="checkbox"/> When <b>Head1 All Nozzles/Head2 All Nozzles</b> is selected: 4</li> </ul>
Pre-Storage Maint.	WH* <sup>2</sup>	<p>Always perform pre-storage maintenance if the printer will not be used for one month or more (and switched off.)</p>
	MS* <sup>2</sup>	<p>See the following for more information.</p>
	All Nozzles	<p> <a href="#">"Long-term Storage (Pre-storage Maintenance)" on page 88</a></p>
Change Color Mode* <sup>2</sup>	9 Color	<p>Items displayed differ depending on the mode currently selected.</p>
	10 Color (WH)	<p>Switching between WH ink and MS ink changes the spot color ink used. If you do not print using WH/MS inks for the specified period of time, switch to 9 Color mode to avoid consuming WH/MS inks.</p>
	10 Color (MS)	<p>For details on execution conditions and procedure, see:</p> <p> <a href="#">"Change Color Mode (SC-S80600 Series/SC-S80600L Series only)" on page 90</a></p>
Grease Carriage Rod	Yes	<p>When <b>Apply secondary carriage rod grease. See manual.</b> is displayed on the control panel screen, select <b>Yes</b> to apply grease to the carriage rod.</p>
	No	<p> <a href="#">"Applying Grease to the Carriage Rod" on page 92</a></p>

## Using the Control Panel Menu

### The Printer Status Menu

These items track printer use and settings.

Setting items and setting values marked with asterisks (\*1) indicate the following printer models.

\*1: For SC-S80600 Series/SC-S60600 Series/SC-S40600 Series only

Item	Parameter	Explanation
Level	Ink	Displays the current remaining amount for the selected item as an icon. 
	Waste ink bottle	
	Wiper Unit	
Print Status Sheet*1	Print	Print a status sheet showing current printer settings, and the status of periodic replacement parts. Use this option to view a variety of information about the printer on a single sheet and help schedule the periodic replacement of parts.
Firmware Version	XXXXXXXX,X_XX,XXXX	View the printer Firmware Version.

### The Preferences Menu

\* indicates default settings.

Setting items and setting values marked with asterisks (\*1) indicate the following printer models.

\*1: For SC-S80600L Series/SC-S60600L Series only

Item	Parameter	Explanation	
Network Setup			
IP Address Setting	Auto	-	
	Panel	IP: XXX.XXX.XXX.XXX	Choose whether IP addresses are obtained automatically using DHCP ( <b>Auto</b> ) or manually ( <b>Panel</b> ). If <b>Panel</b> is selected, enter an IP address, subnet mask, and default gateway address. Contact your system administrator for detailed information.
		SM: XXX.XXX.XXX.XXX	
		DG: XXX.XXX.XXX.XXX	
	Print Status Sheet	Print	Select to print the current network status. Use this information for a complete overview of network settings.
Restore Settings	Yes	Select <b>Yes</b> to restore all items in the Network Setup menu to their default settings.	
	No		
Preferences			

### Using the Control Panel Menu









Item	Parameter	Explanation	
Date And Time	MM/DD/YY HH:MM	Set the printer's built-in clock. The time provided by the clock is used when printing logs and status sheets.	
Language	Japanese	Select the language used in the control panel display.	
	English*		
	French		
	Italian		
	German		
	Portuguese		
	Spanish		
	Dutch		
	Russian		
	Korean		
	Chinese		
Units	Unit: Length	m*	Choose the units of length used in the control panel display and when printing test patterns.
		ft/in	
	Unit: Temperature	°C*	Choose the temperature units used in the control panel display.
		F	
Alert Sound Setting	On*	<p>The items that can be selected differ depending on the model you are using.</p> <p>SC-S80600 Series/SC-S60600 Series/SC-S40600 Series</p> <p>Enable (<b>On</b>) or disable (<b>Off</b>) the buzzer that sounds when an error occurs.</p> <p>SC-S80600L Series/SC-S60600L Series</p> <p>Enable (<b>On</b>) the buzzer that sounds when an error occurs, enable (<b>On (Continuous)</b>) the buzzer that sounds continuously when an error occurs, or disable (<b>Off</b>) the buzzer that sounds when an error occurs.</p>	
	On (Continuous)*, *1		
	Off		
Print Completion Sound*1	On	Enable ( <b>On</b> ) or disable ( <b>Off</b> ) the buzzer sounds to notify you that printing is complete.	
	Off*		
Alert Lamp Setting	ON*	Enable ( <b>ON</b> ) or disable ( <b>OFF</b> ) the alert lamp that lights when an error occurs.	
	OFF		
Reset All Settings	Yes	When you select <b>Yes</b> , all settings in the configuration menu, except for the items in <b>Preferences</b> , are returned to their defaults.	
	No		

## Problem Solver







# Problem Solver

## When a Message is Displayed



If one of the following messages is displayed, read and follow the instructions below.

Messages	What to do
Prepare empty waste ink bottle.	The Waste Ink Bottle is getting full. Ready a new Waste Ink Bottle.  <a href="#">"Options and Consumable Products" on page 124</a>
Ink Cartridge Error Ink cartridge cannot be recognized. Insert again or replace ink cartridge.	<input type="checkbox"/> Remove and reinsert the ink cartridge. If the message persists, insert a new ink cartridge (do not reinsert the ink cartridge that caused the error). <input type="checkbox"/> Condensation may have formed inside the cartridge. Leave it at room temperature for at least four hours before installing the cleaning cartridge.  <a href="#">"Notes on handling ink cartridges/ink supply units" on page 22</a>
Ink Cartridge Error Ink cartridge cannot be detected. Insert again or replace ink cartridge.	
Ink Cartridge Error Replace cleaning cartridge.	<input type="checkbox"/> Remove and reinsert the Cleaning Cartridge. If the message persists, insert a new Cleaning Cartridge (do not reinsert the Cleaning Cartridge that caused the error).  <a href="#">"Replacement procedure" on page 72</a> <input type="checkbox"/> Condensation may have formed inside the cartridge. Leave it at room temperature for at least four hours before installing the cleaning cartridge.
Ink Supply Unit Error Ink supply unit cannot be recognized. Re-insert or replace it.	<input type="checkbox"/> Pull out the tray and re-insert the ink supply unit. If the message persists, even if the tray is loaded in the ink unit, replace the ink supply unit with a new one (the ink supply unit may be defective). <input type="checkbox"/> Condensation may have formed. Leave it at room temperature for at least 4 hours before re-installing the cleaning cartridge.  <a href="#">"Notes on handling ink cartridges/ink supply units" on page 22</a>
Ink Supply Unit Error Ink supply unit cannot be detected. Re-insert or replace it.	
Ink Supply Unit Error Replace cleaning supply unit.	<input type="checkbox"/> Pull out the tray and re-insert the cleaning ink supply unit. If the message persists, even if the tray is loaded in the ink unit, replace the cleaning ink supply unit with a new one (the cleaning ink supply unit may be defective).  <a href="#">"Replacement procedure" on page 82</a> <input type="checkbox"/> Condensation may have formed. Leave it at room temperature for at least 4 hours before re-installing the cleaning cartridge.
Ink Low	The ink is low. Prepare a new ink cartridge/ink supply unit.  <a href="#">"Options and Consumable Products" on page 124</a>
Warming Up... OK Force to start printing.	One or more heaters is still being warmed to the specified temperature. To start printing without waiting for the heater to warm up, press the OK button.
Command Error Check print settings on RIP.	Press the  button and select <b>Job Cancel</b> . Check that the installed software RIP is compatible with the printer.
Clogged nozzles detected. Cleaning recommended.	Stop printing and perform head cleaning if you judge it necessary on inspecting the print results.  <a href="#">"Head Cleaning" on page 86</a>

**Problem Solver**

Messages	What to do
<p>F/W Install Error Firmware update failed. Restart the printer.</p>	<p>Turn the printer off, wait for a few minutes, and then turn on the printer again.</p> <p>Use Epson Edge Dashboard* to update the firmware again.</p> <p>If this message appears in the control panel again, contact your dealer or Epson Support.</p> <p>* Version 1.5 or earlier is called the <b>Epson Control Dashboard</b></p>
<p>Print head is nearing end of service life.</p>	<p>The current print head is nearing the end of its service life.</p> <p>Contact your dealer or Epson Support.</p>
<p>Auto Take-up Reel Unit stopped.</p>	<p>Media is not correctly attached to the Auto Take-up Reel Unit.</p> <p>Press the  button and select <b>Job Cancel</b> to cancel printing.</p> <p>Flip the Auto switch on the Auto Take-up Reel Unit to the Off position, then flip it back and reattach the media to the Auto Take-up Reel Unit.</p> <p> <a href="#">"Take-up with the Printed Side Facing Out" on page 39</a></p> <p> <a href="#">"Take-up with the Printed Side Facing In" on page 41</a></p>
<p>Media Size Error Load correct size media.</p>	<p>The media currently loaded is not the correct width. Raise the media loading lever and remove the media.</p> <p>The narrowest width supported by the printer is 300 mm. Be sure the media is at least 300 mm wide.</p> <p>If this message is displayed even though the media is the correct width, the printer may print if <b>OFF</b> is selected for <b>Media Size Check</b>.</p> <p> <a href="#">"The Printer Setup Menu" on page 108</a></p>
<p>Media Sensor Error Loaded media or sensor has a problem. Refer to manual for error details.</p> <p>Media Sensor Error Refer to manual for error details. Adjust manually?</p>	<p>Press the  button to clear the message from the display.</p> <p>The auto menu of Auto Media Adjust, <b>Auto Nozzle Check</b>, and <b>Media Adjust</b> from Easy Media Setup are not available for the following media settings or conditions.</p> <ul style="list-style-type: none"> <li><input type="checkbox"/> Transparent or colored media</li> <li><input type="checkbox"/> Media with an uneven surface</li> <li><input type="checkbox"/> Media that bleeds-through easily</li> <li><input type="checkbox"/> <b>Platen Gap</b> is set to <b>2.5</b> in the media settings.</li> <li><input type="checkbox"/> The printer is used in a place that is exposed to direct sunlight or interference from other ambient light sources.</li> </ul> <p>In these cases, execute the manual menu.</p> <p>When executing Auto Media Adjust or <b>Media Adjust</b>:  <a href="#">"Optimization of media settings (Media Adjust)" on page 48</a></p> <p>When executing <b>Auto Nozzle Check</b>:  <a href="#">"Printing nozzle check patterns" on page 86</a></p> <p>If the printer is exposed to interference from ambient light sources, shade the printer from these sources and perform the function again; it may succeed. When the function has failed after shading the printer, execute the manual menu.</p> <p>If none of the above applies to you when you are performing auto menu operations in Easy Media Setup or Media Adjust, see Troubleshooting &amp; Tips (Online Manual).</p>

### Problem Solver

Messages	What to do
Roll Type Error Release and then reset the media loading lever, then match Roll Type setting to actual media.	<ul style="list-style-type: none"> <li><input type="checkbox"/> Does the <b>Roll Type</b> specified at media loading match the actual roll type? Raise the media loading lever to resolve the error. Lower the media loading lever again, and follow the on-screen instructions of the printer to correctly specify the <b>Roll Type</b>.</li> </ul>
Press  and perform Head Maintenance.	<p>This message is displayed when regular cleaning has not been performed for more than one month. If you continue to use the printer without performing regular cleaning, ink drops, nozzle clogging, or print head damage may occur in the printer.</p> <p> <a href="#">"Performing Regular Cleaning" on page 65</a></p>
3 layer printing is only available with 2 Head Mode.	<p>SC-S80600 Series/SC-S80600L Series/SC-S60600 Series/SC-S60600L Series only</p> <p>When one head mode is set, three layered printing cannot be performed. Set two head mode, and then perform three layered printing.</p> <p>Change head mode  <a href="#">"The Printer Setup Menu" on page 108</a></p>

## When a Maintenance Call/Service Call Occurs

Error messages	What to do
Maintenance Request Replace Part Now/Replace Part Soon XXXXXXXX	<p>A part used in the printer is nearing the end of its service life.</p> <p>Contact your dealer or Epson Support and tell them the maintenance request code.</p> <p>You cannot clear the maintenance request until the part is replaced. A service call occurs if you continue to use the printer.</p>
Call For Service XXXX Error XXXX Power off and then on. If this doesn't work, note the code and call for service.	<p>A call for service occurs when:</p> <ul style="list-style-type: none"> <li><input type="checkbox"/> The power cable is not connected securely</li> <li><input type="checkbox"/> An error that cannot be cleared occurs</li> </ul> <p>When a call for service has occurred, the printer automatically stops printing. Turn off the printer, disconnect the power cable from the outlet and from the AC inlet on the printer, and then reconnect. Turn on the printer again multiple times.</p> <p>If the same call for service is displayed on the LCD panel, contact your dealer or EpsonSupport for assistance. Tell them the call for service code is "XXXX".</p>

## Problem Solver

## Troubleshooting

### You cannot print (because the printer does not work)

#### The printer does not turn on.

■ **Is the power cable plugged into the electrical outlet or the printer?**

Make sure the power cable is securely plugged into the printer.

■ **Is there any problem with the electrical outlet?**

Make sure your outlet works by connecting the power cable for another electric product.

#### The printer is not communicating with the computer.

■ **Is the cable plugged in properly?**

Make sure the printer's interface cable is securely plugged into the correct terminal of the computer and the printer. Also, make sure the cable is not broken nor bent. If you have a spare cable, try connecting with the spare cable.

■ **Does the interface cable specification match the specifications for the computer?**

Make sure the interface cable specifications match the specifications for the printer and the computer.

 ["Specifications Table" on page 139](#)

■ **When using a USB hub, is it being used correctly?**

In the USB specification, daisy-chains of up to five USB hubs are possible. However, we recommend that you connect the printer to the first hub connected directly to the computer. Depending on the hub you are using, the operation of the printer may become unstable. If this should occur, plug the USB cable directly into your computer's USB port.

■ **Is the USB hub recognized correctly?**

Make sure the USB hub is recognized correctly on the computer. If it has, disconnect the USB hub from the computer and connect the computer directly to the printer. Ask the USB hub manufacturer about USB hub operation.

### You cannot print under the network environment.

■ **Are the network settings correct?**

Ask your network administrator for the network settings.

■ **Connect the printer directly to the computer using a USB cable, and then try to print.**

If you can print via USB, there are some problems on the network environment. Ask your system administrator, or refer to the manual for your network system. If you cannot print via USB, see the appropriate section in this User's Guide.

#### The printer has an error.

■ **Confirm if errors have occurred in the printer by checking the lights and messages on the printer's control panel.**

 ["Control panel" on page 15](#)

 ["When a Message is Displayed" on page 116](#)

### The printer sounds like it is printing, but nothing prints

#### The print head moves, but nothing prints.

■ **Confirm the printer operation.**

Print a test pattern. Test patterns can be printed without connecting the printer to a computer and hence can be used to check printer function and status.  ["Printing nozzle check patterns" on page 86](#)

Refer to the following section for information on what to do if the pattern does not print correctly.

■ **Is Circulating ink... displayed on the screen of the control panel?**

The printer is performing auto ink circulation to prevent spot color ink sedimentation in the print head or tube.

If **Cancel** is displayed on the lower left of the screen, press the  button to cancel ink circulation. However, it cannot be canceled while ink circulation is required.

 ["Notes on Usage of WH/MS Ink \(SC-S80600 Series/SC-S80600L Series\)" on page 23](#)

## Problem Solver

### Test pattern does not print correctly.

- Perform head cleaning.**  
The nozzles may be clogged. Print a test pattern again after performing head cleaning.

 ["Head Cleaning" on page 86](#)

- Has the printer been left unused for a long time?**  
If the printer has not been used for a long time, the nozzles may have dried up and have been clogged. Steps to take when the printer has not been used for a long time  ["Notes when not using the printer" on page 21](#)

### The prints are not what you expected

#### Print quality is poor, uneven, too light, too dark, obvious graininess, or the tone differs.

- Are the print head nozzles clogged?**  
If the nozzles are clogged, specific nozzles do not fire ink and the print quality declines. Try printing a test pattern.

 ["Printing nozzle check patterns" on page 86](#)

- Perform Head Alignment.**  
Given that there is a slight gap between the print head and the media, the landing sites for the different colors of ink may be affected by humidity, temperature, inertial forces imparted by the print head, the direction of the print head as it moves from right to left or left to right, or the use of two print heads (all models except SC-S40600 Series). As a result, the printing result may show obvious graininess or out-of-focus characteristics.

Select **Media Adjust - Head Alignment** in the media settings to adjust a print head misalignment that occurs during printing.

 ["Head Alignment" on page 50](#)

- Perform Feed Adjustment.**  
Large discrepancies in the feed amount cause banding (horizontal banding, tint unevenness, or stripes). Select **Media Adjust - Feed Adjustment** in the media settings to make adjustment based on the target media.

 ["Feed Adjustment" on page 49](#)

- Are you using the recommended genuine Epson ink cartridge/ink supply unit?**  
This printer is developed for use with Epson ink cartridges/ink supply units. If you use non-Epson ink cartridges, printouts may be faint, or the color of the printed image may be changed because the remaining ink level is not correctly detected. Be sure to use the correct ink cartridge/ink supply unit.

- Are you using an old ink cartridge/ink supply unit?**  
The print quality declines when an old ink cartridge/ink supply unit is used. Replace the old ink cartridge/ink supply unit with a new one. Use all the ink in the ink cartridge/ink supply unit before the date printed on the package, within 6 months from the day the package containing the ink cartridge is opened, or within 6 months from the day the ink supply unit was inserted into the tray, whichever is sooner.

- Are the heaters at the correct temperature?**  
Raise the temperature if the print results are blurred or smudged or the ink clots. Note, however, that raising the temperature too high can cause the media to shrink, wrinkle, or deteriorate.

In addition, the heaters may require some time to reach the desired temperature if the ambient temperature is low. The heaters may also not have the desired effect after reaching the selected temperature if the media is too cold. Allow the media to warm to room temperature before use.

- Are media settings correct?**  
Confirm that the media settings in the software RIP or on the printer match the media actually in use.

- Is Data Width selected for Head Movement?**  
Selecting **Data Width for Head Movement** in the setup menu increases print speed but may slightly reduce print quality. For better quality results, select **Printer Full Width for Head Movement**.

 ["The Printer Setup Menu" on page 108](#)

- Have you compared the printing result with the image on the display monitor?**  
Since monitors and printers produce colors differently, printed colors will not always match on-screen colors perfectly.

- Was a printer cover opened during printing?**  
Opening covers during printing causes the print head to stop abruptly, resulting in uneven colors. Do not open the covers while printing is in progress.



## Problem Solver

### ■ Shake the WH/MS ink cartridge or the WH/MS ink supply unit.

When using SC-S80600 Series/SC-S80600L Series as 10 color mode, sedimentation may occur in the WH/MS inks (components settling to the bottom of the liquid). Remove the ink cartridge or the tray, shake it thoroughly, and then perform **Ink Circulation** several times.

Shaking Ink Cartridges  ["Shaking" on page 71](#)

Shaking Ink Supply Units  ["Shaking" on page 74](#)

Ink Circulation  ["The Maintenance Menu" on page 111](#)

If the problem persists, perform **Ink Refresh**.

 ["The Maintenance Menu" on page 111](#)

## The print is not positioned properly on the media.

### ■ Is the media loaded correctly and are the margins correct?

If the media is not loaded correctly, the results may be off center or part of the data may not be printed. You should also check whether the correct options are selected for **Side Margin** and **Print Start Position** in the setup menu.

 ["Loading media" on page 30](#)

 ["The Printer Setup Menu" on page 108](#)

### ■ Is the media skewed?

If **OFF** is selected for **Media Skew Check** in the setup menu, printing will continue when the media is skewed and data will appear outside the print area. Set **Media Skew Check** to **ON** in the Menu.

 ["The Printer Setup Menu" on page 108](#)

### ■ Is the media wide enough for the print data?

Although printing normally stops if the print image is wider than the media, data will be printed beyond the edges of the media if **OFF** is selected for **Media Size Check** in the setup menu. Choose **ON** for **Media Size Check** in the setup menu.

 ["The Printer Setup Menu" on page 108](#)

## Vertical ruled lines are misaligned.

### ■ Is the media wavy?

Certain types of media may develop waves under some conditions (humidity and temperature) while installed in the printer. If a wave has developed, press the **▼** button in the control panel to feed the media and avoid the affected area. We recommend that you lower the temperature and humidity to prevent waves developing.

### ■ Is the print head misaligned?

If the print head is misaligned, ruled lines may be misaligned accordingly. In this case, select **Media Adjust - Head Alignment** in the media settings to adjust a print head misalignment that occurs during printing.

 ["Head Alignment" on page 50](#)

## Media

### Media Jams.

### ■ Is media curled, folded, curved, creased, or waved?

Cut and remove the curled, folded, curved, creased, or waved part.

 ["Cutting Media" on page 52](#)

### ■ Is media loaded just before printing?

The pressure rollers may crease media left in the printer, or the media may also become wavy or curled.

### ■ Is the media too thick or too thin?

Check the media specifications to determine whether it can be used in the printer.

 ["Supported Media" on page 132](#)

For information on how to configure print settings using the software RIP, contact the RIP manufacturer.

## Printing does not stop when the roll ends.

### ■ Is the item for having the printer detect the end of the media set to OFF?

When **Media End Check** is set to **OFF** from the Printer Setup menu, the end of the media is not detected.

 ["The Printer Setup Menu" on page 108](#)

**Problem Solver**

**Removing Jammed Media.**

Follow the steps below to remove jammed media.

**⚠ Caution:**

*Be careful not to trap your hands or fingers when opening or closing the front cover. Failure to observe this precaution could result in injury.*

- 1** Turn off the printer.  
If a message is displayed and the printer will not turn off, unplug both power cables.

- 2** Open the front cover.

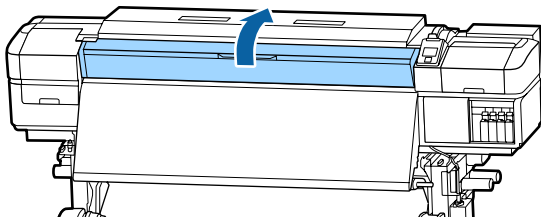

- 3** Move the media edge plates to the right and left sides of the platen. Hold both tabs on the media edge plates to move them.

**⚠ Important:**

*Cease use of the printer if the media edge plates are deformed. Continued use could damage the pressure rollers or print head.*

*Contact your dealer or Epson Support.*

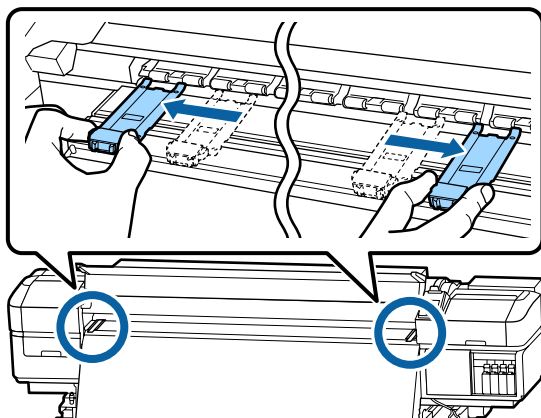

- 4** If the print head is over the media, move it away from the jam.

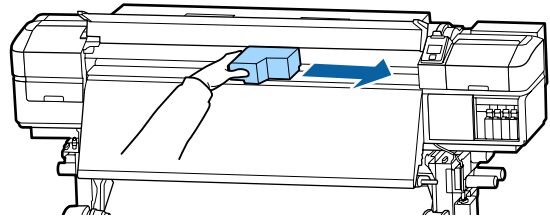

**⚠ Important:**

*Move the print head only after moving the media edge plates out of the way. Contact with deformed media edge plates could damage the print head.*

- 5** Raise the media loading lever.

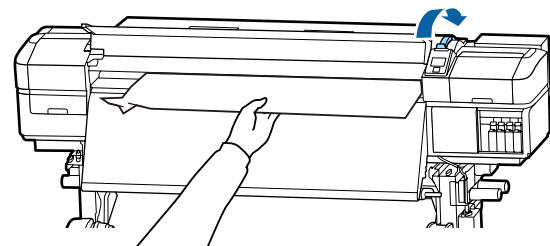

- 6** Pull the media to the cutter groove and use a cutter to remove torn or creased portions.

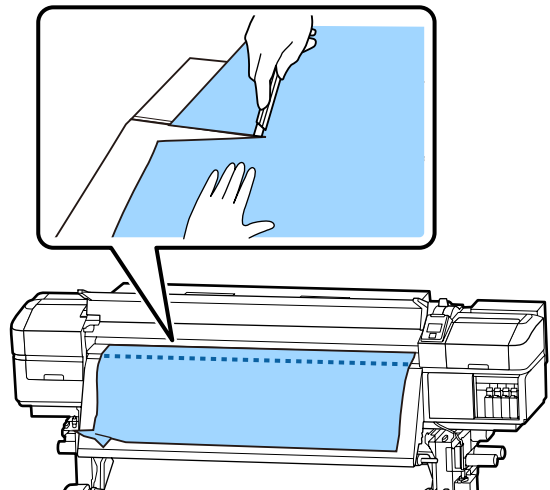

- 7** Manually rewind the cut media.

- 8** Remove any media that remains inside the printer.

## Problem Solver

9

Turn the printer on.



### **Important:**

*If the printer is left off for an extended period, the print head will be left uncapped and dry out, and will not print properly when printing resumes.*

*Turning the printer on automatically caps the print head.*

Reload the media and resume printing.

 ["Loading media" on page 30](#)

## Media slips off when printing starts

### ■ **Is Mode 2 set in After Heater Feed, and is the media being cut?**

If media is cut at the point just after printing and then rewound when the next print job starts, the media may come off the pressurization roller and printing cannot be performed.

When cutting after printing, hold down the ▲ button to rewind the end of the print to the cutter groove, and then cut.

## Others

### Heaters Turn off or the Optional Additional Print Drying System Stops.

- The pre-, platen, and after heaters will turn off if no print job is received for some time and no error occurs. The time before the heaters automatically switch to OFF can be selected using the **Sleep Mode** option in the setup menu.  ["The Printer Setup Menu" on page 108](#)

The heaters will be reactivated when a print job is received, the media loading lever is used, or another operation involving printer hardware is performed.

An Additional Print Drying System is supplied with the SC-S60600 Series/SC-S60600L Series.

## The control panel display keeps turning off.

### ■ **Is the printer in sleep mode?**

When no operations are performed on the printer for the time set in **Sleep Mode** from the setup menu, the printer enters sleep mode. The time before entering sleep mode can be changed in the Printer Setup menu.

 ["The Printer Setup Menu" on page 108](#)

The heaters will be reactivated and sleep mode will end when a print job is received, the media loading lever is used, or another operation involving printer hardware is performed.

## Forgotten password for network setup protection

- **Contact your dealer or Epson Support.**

## The red light is on inside the printer.

- **This is not a failure.**  
The red light is a light inside the printer.

## Appendix

---

# Appendix

---

## Options and Consumable Products

For the latest information, see the Epson Web site. (as of June, 2019)

Epson recommends the use of genuine Epson ink cartridges/Ink Supply Unit. Epson cannot guarantee the quality or reliability of nongenuine ink. The use of non-genuine ink may cause damage that is not covered by Epson's warranties, and under certain circumstances, may cause erratic printer behavior.

Information about non-genuine ink levels may not be displayed, and use of non-genuine ink is recorded for possible use in service support.

---

## Ink cartridges

### For SC-S80600 Series/SC-S60600 Series/SC-S40600 Series

Printer model	Product	Part number	
SC-S80600	Ink cartridges	Black	T8901
		Cyan	T8902
		Magenta	T8903
		Yellow	T8904
		Light Cyan	T8905
		Light Magenta	T8906
		Light Black	T8907
		Orange	T8908
		Red	T8909
		White	T890A
		Metallic Silver	T890B

**Appendix**

Printer model	Product		Part number
SC-S80600 (Australia and New Zealand)	Ink cartridges	Black	T8331
		Cyan	T8332
		Magenta	T8333
		Yellow	T8334
		Light Cyan	T8335
		Light Magenta	T8336
		Light Black	T8337
		Orange	T8338
		Red	T8339
		White	T833A
		Metallic Silver	T833B
SC-S80610	Ink cartridges	Black	T8911
		Cyan	T8912
		Magenta	T8913
		Yellow	T8914
		Light Cyan	T8915
		Light Magenta	T8916
		Light Black	T8917
		Orange	T8918
		Red	T8919
		White	T891A
		Metallic Silver	T891B

## Appendix

Printer model	Product		Part number
SC-S80670	Ink cartridges	Black	T8921
		Cyan	T8922
		Magenta	T8923
		Yellow	T8924
		Light Cyan	T8925
		Light Magenta	T8926
		Light Black	T8927
		Orange	T8928
		Red	T8929
		White	T892A
		Metallic Silver	T892B
SC-S80680	Ink cartridges	Black	T8931
		Cyan	T8932
		Magenta	T8933
		Yellow	T8934
		Light Cyan	T8935
		Light Magenta	T8936
		Light Black	T8937
		Orange	T8938
		Red	T8939
		White	T893A
		Metallic Silver	T893B
SC-S40600 SC-S60600	Ink cartridges	Black	T8901
		Cyan	T8902
		Magenta	T8903
		Yellow	T8904
SC-S40600 SC-S60600 (Australia and New Zealand)	Ink cartridges	Black	T8331
		Cyan	T8332
		Magenta	T8333
		Yellow	T8334

**Appendix**

Printer model	Product		Part number
SC-S40610 SC-S60610	Ink cartridges	Black	T8911
		Cyan	T8912
		Magenta	T8913
		Yellow	T8914
SC-S40670 SC-S60670	Ink cartridges	Black	T8921
		Cyan	T8922
		Magenta	T8923
		Yellow	T8924
SC-S40680 SC-S60680	Ink cartridges	Black	T8931
		Cyan	T8932
		Magenta	T8933
		Yellow	T8934

---

## Ink Supply Unit

### For SC-S80600L Series/SC-S60600L Series

Printer model	Product		Part number
SC-S80600L	Ink Supply Unit	Black	T45L1
		Cyan	T45L2
		Magenta	T45L3
		Yellow	T45L4
		Light Cyan	T45L5
		Light Magenta	T45L6
		Light Black	T45L7
		Orange	T45L8
		Red	T45L9
		White	T45LA
		Metallic Silver	T45LB

**Appendix**

Printer model	Product		Part number
SC-S80610L	Ink Supply Unit	Black	T45N1
		Cyan	T45N2
		Magenta	T45N3
		Yellow	T45N4
		Light Cyan	T45N5
		Light Magenta	T45N6
		Light Black	T45N7
		Orange	T45N8
		Red	T45N9
		White	T45NA
		Metallic Silver	T45NB
SC-S80660L	Ink Supply Unit	Black	T45M1
		Cyan	T45M2
		Magenta	T45M3
		Yellow	T45M4
		Light Cyan	T45M5
		Light Magenta	T45M6
		Light Black	T45M7
		Orange	T45M8
		Red	T45M9
		White	T45MA
		Metallic Silver	T45MB



**Appendix**

<b>Printer model</b>	<b>Product</b>		<b>Part number</b>
SC-S80670L	Ink Supply Unit	Black	T45P1
		Cyan	T45P2
		Magenta	T45P3
		Yellow	T45P4
		Light Cyan	T45P5
		Light Magenta	T45P6
		Light Black	T45P7
		Orange	T45P8
		Red	T45P9
		White	T45PA
		Metallic Silver	T45PB
SC-S80680L	Ink Supply Unit	Black	T45Q1
		Cyan	T45Q2
		Magenta	T45Q3
		Yellow	T45Q4
		Light Cyan	T45Q5
		Light Magenta	T45Q6
		Light Black	T45Q7
		Orange	T45Q8
		Red	T45Q9
		White	T45QA
		Metallic Silver	T45QB
SC-S60600L	Ink Supply Unit	Black	T45L1
		Cyan	T45L2
		Magenta	T45L3
		Yellow	T45L4
SC-S60610L	Ink Supply Unit	Black	T45N1
		Cyan	T45N2
		Magenta	T45N3
		Yellow	T45N4

## Appendix

Printer model	Product		Part number
SC-S60660L	Ink Supply Unit	Black	T45M1
		Cyan	T45M2
		Magenta	T45M3
		Yellow	T45M4
SC-S60670L	Ink Supply Unit	Black	T45P1
		Cyan	T45P2
		Magenta	T45P3
		Yellow	T45P4
SC-S60680L	Ink Supply Unit	Black	T45Q1
		Cyan	T45Q2
		Magenta	T45Q3
		Yellow	T45Q4

## Maintenance Items

### For SC-S80600 Series/SC-S60600 Series/SC-S40600 Series

Product	Part number	Explanation
Cleaning cartridge	T6960	Use when performing Pre-Storage Maint..
Cleaning cartridge (Australia and New Zealand)	T8330	
Maintenance Parts Kit (except for SC-S40680/SC-S60680/ SC-S80680)	C13S210044	The following consumable items are included in one maintenance set. <ul style="list-style-type: none"> <li><input type="checkbox"/> Wiper unit (x1)</li> <li><input type="checkbox"/> Flushing pad (x1)</li> <li><input type="checkbox"/> Air filters (x2)</li> <li><input type="checkbox"/> Gloves (x2)</li> </ul>
Maintenance Parts Kit (for SC-S40680/SC-S60680/ SC-S80680)	C13S210045	
Ink Cleaner	T6993	Identical to the ink cleaner supplied with the printer.
Waste Ink Bottle	T7240	Identical to the Waste Ink Bottle supplied with the printer.
Cleaning Stick	C13S090013	Identical to the Maintenance Kit items supplied with the printer.
Clean Room Wiper*1	C13S090016	

\*1 Not available for purchase in some countries and regions. We recommend BEMCOT M-3II by Asahi Kasei Corporation when purchasing commercial products.

## Appendix

## For SC-S80600L Series/SC-S60600L Series

Product	Part number	Explanation
Cleaning Ink Supply Unit (except for SC-S80660L/ SC-S60660L)	T44A5	Use when performing Pre-Storage Maint..
Cleaning Ink Supply Unit (for SC-S80660L/SC-S60660L)	T44A6	
Maintenance Parts Kit (except for SC-S80680L/ SC-S60680L)	C13S210093	The following consumable items are included in one maintenance set. <input type="checkbox"/> Wiper unit (x1) <input type="checkbox"/> Flushing pad (x1) <input type="checkbox"/> Air filters (x2) <input type="checkbox"/> Gloves (x2)
Maintenance Parts Kit (for SC-S80680L/SC-S60680L)	C13S210094	
Ink Cleaner	T6993	Identical to the ink cleaner supplied with the printer.
Waste Ink Bottle (except for SC-S80680L/ SC-S60680L)	C13S210071	Identical to the Waste Ink Bottle supplied with the printer.
Waste Ink Bottle (for SC-S80680L/SC-S60680L)	C13S210072	
Cleaning Stick	C13S090013	Identical to the Maintenance Kit items supplied with the printer.
Clean Room Wiper*1	C13S090016	

\*1 Not available for purchase in some countries and regions. We recommend BEMCOT M-3II by Asahi Kasei Corporation when purchasing commercial products.

**Appendix**

# PANTONE Color Explanation

There are many variables in process reproduction of colors generated by the SC-S80600 Series/SC-S80600L Series, any one of which may affect quality of the PANTONE® Color simulation.

For optimal results, we recommend that the following materials are used.

Color Management: ONYX RIP

Print Quality: 1440 × 1440 dpi 36pass

Media: ILFORD Nano Solvent Premium Photo Paper Gloss

Ink: Genuine Epson ink

## Supported Media

The following media can be used with the printer.

Print quality is greatly affected by the type and quality of media used. Choose a media suited to the task at hand. For information on use, refer to the documentation supplied with the media or contact the manufacturer. Before buying media in large quantities, try printing on a smaller sample and check the results.

 **Important:**

*Do not use media that is wrinkled, scuffed, torn, or dirty.*

### Roll media

Roll core size	2 or 3 inch
Roll outer diameter	Media Feeding Unit: Up to 250 mm Auto Take-up Reel Unit: Up to 200 mm
Media width	300 to 1626 mm (64 inch)
Media thickness	Up to 1 mm
Roll weight	Up to 45 kg

### Cut media

Media width	300 to 1626 mm (64 inch)
Media length	500 mm or more
Media thickness	Up to 1 mm

## Appendix

# Moving and Transporting the Printer

This section describes how to move and transport the product.

## Moving the Printer

This section assumes that the product is being moved to another location on the same floor without traversing stairs, ramps, or lifts. See below for information on moving the printer between floors or to another building.

 [“Transport” on page 134](#)



### Caution:

Do not tilt the product more than 10 degrees forward or back while moving it. Failure to observe this precaution could result in the printer falling over, causing accidents.



### Important:

- Do not remove the ink cartridges/ink supply units. Failure to observe this precaution could cause the print head nozzles to dry out.
- If you are using the SC-S80600L Series/SC-S60600L Series, be sure to transport the printer under the following conditions.
  - Do not separate the ink unit and the printer. (Transport the printer with the ink tube connector connected to the back of the printer and the connector locked.)
  - Make sure the fixing wire is fastened.

## Getting Ready

- 1** Confirm that the printer is off.
- 2** Remove the Waste Ink Bottle.  
 [“Replacing the Waste Ink Bottle” on page 77](#)

- 3** Disconnect the power cords and all other cables.  
If you are using the SC-S80600L Series/SC-S60600L Series, remove the following from the ink unit.

- Power cable and connection cable
- Overturn-prevention plate (for both sides)

- 4** Remove media from the Media Feeding Unit and Auto Take-up Reel Unit.

- 5** Unlock the two casters at the front.  
If you are using the SC-S80600L Series/SC-S60600L Series, unlock all 4 of the ink unit's casters.

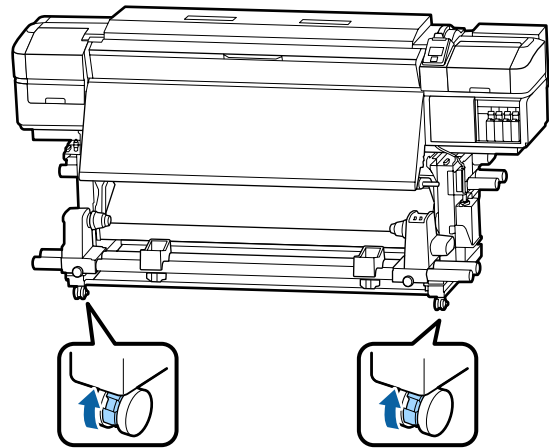

## Appendix

### **!** Important:

When performing level adjustment using the adjusters, make sure you raise the adjusters above the casters before trying to move the printer. Moving the printer without raising the adjusters could cause malfunction. You need the spanner supplied to adjust the adjusters.

1. Loosen the nut on the top of the adjuster.
2. Turn the nut on the bottom counter-clockwise.
3. Check that it is above the caster.

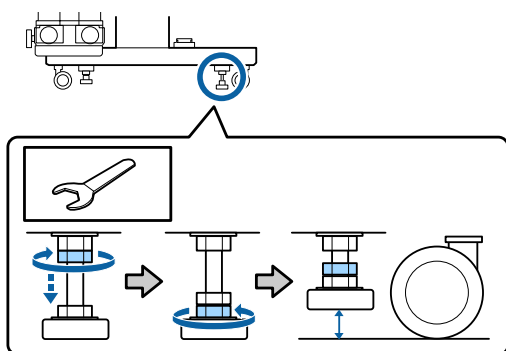

- 6** Move the printer.

Have 2 people, 1 on either side of the printer, move the printer.

If you are using the SC-S80600L Series/ SC-S60600L Series, use a total of 3 people for moving: 2 to move the printer and 1 to move the ink unit. Also, move so that the printer goes first in the direction you are going.

### **!** Important:

Use the casters on the dedicated printer stand to move the printer indoors a short distance over a level floor. They can not be used for transport.

## Post-Move Setup

After moving the printer, follow the steps below to ready it for use.

- 1** Check that the new location is appropriate, and attach the parts that were removed.

Setup Guide

If you do not have the *Setup Guide* on hand, select and refer to the model of your printer from <https://epson.sn>.

- 2** Plug in the power cables and turn the printer on.  
 Setup Guide
- 3** Perform a nozzle check to check for clogged nozzles.  
 "Printing nozzle check patterns" on page 86
- 4** Perform **Media Adjust** in the setup menu, and check the print quality.  
 "Optimization of media settings (Media Adjust)" on page 48

## Transport

Before transporting the printer, contact your dealer or Epson Support.

"Where To Get Help" on page 142

## Appendix

## Media Settings List for Each Media Type

The following table shows the media settings registered when a media type is selected.

Item	Media Type					
	Adhesive Vinyl	Banner	Film	Canvas	Textile	Paper/ Other
Platen Gap	1.6	2.0	1.6	2.0	2.0	1.6
Pre-heater temperature	40°C	40°C	40°C	40°C	40°C	40°C
Platen heater temperature	40°C	40°C	40°C	40°C	40°C	40°C
After heater temperature	50°C	50°C	50°C	50°C	50°C	50°C
Drying Time Per Pass	0 sec	0 sec	0 sec	0 sec	0 sec	0 sec
After Heater Feed	OFF	OFF	OFF	OFF	OFF	OFF
Additional Dryer*	ON	ON	ON	ON	ON	ON
Media Tension	Lv2	Lv2	Lv2	Lv2	Lv4	Lv2
Media Suction	4	4	4	4	4	4
Head Movement	Data Width	Data Width	Data Width	Data Width	Data Width	Data Width
Multi Strike Printing	OFF	OFF	OFF	OFF	OFF	OFF
Feed Speed Limiter	OFF	OFF	OFF	OFF	OFF	OFF
Pressure Roller Load	Heavy	Medium	Medium	Medium	Low	Heavy
Remove Skew	ON	ON	OFF	ON	ON	ON
Periodical Cleaning	Auto	Auto	Auto	Auto	Auto	Auto

\* For the SC-S60600 Series/SC-S60600L Series or the SC-S80600 Series/SC-S80600L Series/SC-S40600 Series with the optional additional print drying system installed.

## Appendix

# System Requirements

This software can be used in the following environments. (As of June 2019)

The supported operating systems may change.

For the latest information, see the Epson Web site.

## Epson Edge Dashboard

### **Important:**

*Make sure the computer on which the Epson Edge Dashboard is installed meets the following requirements. If these requirements are not met, the software cannot monitor the printer correctly.*

- Disable your computer's hibernate function.*
- Disable the sleep function so that the computer does not enter sleep status.*

### Windows

Operating systems	Windows 7 SP1 / Windows 7 x64 SP1 Windows 8 / Windows 8 x64 Windows 8.1 / Windows 8.1 x64 Windows 10 / Windows 10 x64
CPU	Multi-core processor (3.0 GHz or better recommended)
Free memory	4 GB or more
Hard disk (free space during installation)	2 GB or more
Display resolution	1280 × 1024 or higher
Communication interface	High Speed USB Ethernet 1000Base-T
Browser	Internet Explorer 11 Microsoft Edge

### Mac

Operating systems	Mac OS X 10.7 Lion or later
CPU	Multi-core processor (3.0 GHz or better recommended)
Free memory	4 GB or more
Hard disk (free space during installation)	2 GB or more
Display resolution	1280 × 1024 or higher



## Appendix

Communication interface	High Speed USB Ethernet 1000Base-T
Browser	Safari 6 or later

### Linux

Distribution	Debian 8.6 64bit (MATE desktop environment only) or later
CPU	Multi-core processor (3.0 GHz or better recommended)
Free memory	4 GB or more
Hard disk (free space during installation)	2 GB or more
Display resolution	1280 × 1024 or higher
Communication interface	High Speed USB Ethernet 1000Base-T
Browser	Mozilla Firefox 45 (ESR) or later

---

## Epson Edge Print

Operating system	Windows 7 SP1 / Windows 7 x64 SP1 Windows 8 / Windows 8 x64 Windows 8.1 / Windows 8.1 x64 Windows 10 / Windows 10 x64 * 64 bit is recommended
CPU	Multi-core processor (3.0 GHz or better recommended)
Available memory space	4 GB or more
Hard disk (Available volume to install)	50 GB or more
Display resolution	1280 × 1024 or higher
Communication interface	High Speed USB Ethernet 100Base-TX/1000Base-T

The computer on which this software is installed is expected to be able to simultaneously use other applications, such as Adobe Illustrator. So, we recommend using a computer with the highest specifications available.

In addition, the data that this software handles is normally several GB, and could reach several tens of GB for long high-quality print jobs. Because of this, we recommend a computer that has a hard disk with sufficient surplus available memory capacity.

---

## Remote Manager

The following is a list of supported browsers. Make sure you are using the latest version.

## **Appendix**

Internet Explorer 11, Microsoft Edge, Firefox, Chrome, Safari

Appendix

# Specifications Table

Printer Specifications	
Printing method	On-demand ink jet
Nozzle configuration	<p>SC-S80600 Series/SC-S80600L Series:</p> <p>360 nozzles × 2 rows × 10 colors (Orange, Light Black, Black, Cyan, Magenta, Yellow, Red, Light Cyan, Light Magenta, White/Metallic Silver)</p> <p>SC-S60600 Series/SC-S60600L Series:</p> <p>360 nozzles × 2 × 2 rows × 4 colors (Black, Cyan, Magenta, Yellow)</p> <p>SC-S40600 Series:</p> <p>360 nozzles × 2 rows × 4 colors (Black, Cyan, Magenta, Yellow)</p>
Resolution (maximum)	1440 × 1440 dpi
Control code	ESC/P raster (undisclosed command)
Media feed method	Friction feed
Built-in memory	<p>SC-S80600 Series/SC-S80600L Series:</p> <p>2 GB for Main 128 MB for Network</p> <p>SC-S60600 Series/SC-S60600L Series/SC-S40600 Series:</p> <p>512 MB for Main 128 MB for Network</p>
Interface	<p>Hi-Speed USB-Compatible with the USB 2.0 Specification.</p> <p>100Base-TX/1000Base-T*1</p>
Rated voltage (#1, #2 and additional print drying system*2)	<p>AC 100 to 120V</p> <p>AC 200 to 240V</p>
Rated frequency (#1 and #2)	50/60 Hz
Rated frequency (additional print drying system*2)	50/60 Hz

Printer Specifications	
Rated current (#1, #2)	<p>10A (100 to 120V AC)</p> <p>5A (200 to 240V AC)</p>
Rated current (external drying fan units*2)	<p>1A (100 to 120V AC)</p> <p>0.5A (200 to 240V AC)</p>
Power consumption	<p>SC-S80600 Series (Total for #1 and #2)</p> <p>Printing: Approx. 650 W</p> <p>Ready mode: Approx. 380 W</p> <p>Sleep mode: Approx. 14 W</p> <p>Power off: Approx. 1.5 W</p>
	<p>SC-S80600L Series (Total for #1 and #2)</p> <p>Printing: Approx. 640 W</p> <p>Ready mode: Approx. 400 W</p> <p>Sleep mode: Approx. 24 W</p> <p>Power off: Approx. 1.5 W</p>
	<p>SC-S60600 Series (Total for #1, #2 and additional print drying system*2)</p> <p>Printing: Approx. 745 W</p> <p>Ready mode: Approx. 445 W</p> <p>Sleep mode: Approx. 13 W</p> <p>Power off: Approx. 1.8 W</p>
	<p>SC-S60600L Series (Total for #1, #2 and additional print drying system*2)</p> <p>Printing: Approx. 865 W</p> <p>Ready mode: Approx. 525 W</p> <p>Sleep mode: Approx. 23 W</p> <p>Power off: Approx. 1.8 W</p>
Temperature	<p>SC-S40600 Series (Total for #1 and #2)</p> <p>Printing: Approx. 480 W</p> <p>Ready mode: Approx. 330 W</p> <p>Sleep mode: Approx. 12 W</p> <p>Power off: Approx. 1.5 W</p>
	<p>Operating: 15 to 35 °C (20 to 32 °C recommended)</p> <p>Storage: -20 to 40 °C (within a month at 40 °C)</p>

**Appendix**

Printer Specifications	
Humidity	Operating: 20 to 80% (40 to 60% recommended) (without condensation) Storage: 5 to 85% (without condensation)
Operation temperature and humidity range 	
Dimension	SC-S60600 Series Storage dimensions: 2620 (W) × 972 (D) × 1338 (H) mm Maximum dimensions: 2620 (W) × 1147 (D) × 1671 (H) mm
	SC-S60600L Series Storage dimensions: 2766 (W) × 972 (D) × 1338 (H) mm Maximum dimensions: 2766 (W) × 1147 (D) × 1671 (H) mm
	SC-S80600 Series/SC-S40600 Series Storage dimensions: 2620 (W) × 880 (D) × 1338 (H) mm Maximum dimensions: 2620 (W) × 1090 (D) × 1671 (H) mm
	SC-S80600L Series Storage dimensions: 2766 (W) × 880 (D) × 1338 (H) mm Maximum dimensions: 2766 (W) × 1090 (D) × 1671 (H) mm

Printer Specifications	
Weight*3	SC-S80600 Series: Approx. 284 kg SC-S80600L Series: Approx. 328 kg SC-S60600 Series: Approx. 291 kg SC-S60600L Series: Approx. 336 kg SC-S40600 Series: Approx. 279 kg

\*1 Use a shielded twisted pair cable (category 5e or better).

\*2 For Additional Print Drying System supplied with SC-S60600 Series/SC-S60600L Series

\*3 Not including ink cartridges/ink supply units

**Appendix**

<b>Ink Specifications</b>	
Type	Dedicated ink cartridges/ink supply units
Pigment ink	<p>SC-S80600 Series/SC-S80600L Series:</p> <p>Orange, Light Black, Black, Cyan, Magenta, Yellow, Red, Light Cyan, Light Magenta, White/Metallic Silver</p> <p>SC-S60600 Series/SC-S60600L Series/SC-S40600 Series:</p> <p>Black, Cyan, Magenta, Yellow</p>
Use by date	Time limit printed on the package, cartridge, and ink supply unit (when stored at normal temperature)
Print quality guarantee expiry	Six months (from date package containing ink cartridge is opened/ from date attached to tray of ink unit)
Storage temperature	<p>Uninstalled:</p> <p>-20 to 40°C (within four days at -20°C, within a month at 40°C)</p> <p>Installed:</p> <p>-20 to 40°C (within four days at -20°C, within four days at 40°C)</p> <p>Transporting:</p> <p>-20 to 60°C (within four days at -20°C, within a month at 40°C, within 72 hours at 60°C)</p>
Dimensions	<p>Cartridge:</p> <p>40 (W) × 305 (D) × 110 (H) mm</p>
	<p>Ink supply unit:</p> <p>180 (W) × 410 (D) × 30 (H) mm</p>
Capacity	<p>Cartridge:</p> <p>WH: 600 ml</p> <p>MS: 350 ml</p> <p>Other colors: 700 ml</p>
	<p>Ink supply unit:</p> <p>MS: 500 ml</p> <p>Cleaning: 700 ml</p> <p>Other colors: 1500 ml</p>



**Important:**

- Do not refill the the ink cartridge with ink.
- Use the printer at an altitude of 2000 m or less.



**Warning:**

*This is a class A product. In a domestic environment this product may cause radio interference in which case the user may be required to take adequate measures.*

**Information of EU declaration of conformity**

The full text of the EU declaration of conformity of this equipment is available at the following internet address.

<https://www.epson.eu/conformity>

## Where To Get Help

---

# Where To Get Help

---

## Technical Support Web Site

Epson's Technical Support Web Site provides help with problems that cannot be solved using the troubleshooting information in your product documentation. If you have a Web browser and can connect to the Internet, access the site at:

<https://support.epson.net/>

If you need the latest drivers, FAQs, manuals, or other downloadables, access the site at:

<https://www.epson.com>

Then, select the support section of your local Epson Web site.

## Contacting Epson Support

---

### Before Contacting Epson

If your Epson product is not operating properly and you cannot solve the problem using the troubleshooting information in your product documentation, contact Epson support services for assistance. If Epson support for your area is not listed below, contact the dealer where you purchased your product.

Epson support will be able to help you much more quickly if you give them the following information:

- Product serial number  
(The serial number label is usually on the back of the product.)
- Product model
- Product software version  
(Click **About**, **Version Info**, or similar button in the product software.)
- Brand and model of your computer
- Your computer operating system name and version
- Names and versions of the software applications you normally use with your product

## Where To Get Help

### Help for Users in North America

Epson provides the technical support services listed below.

#### Internet Support

Visit Epson's support website at <https://epson.com/support> and select your product for solutions to common problems. You can download drivers and documentation, get FAQs and troubleshooting advice, or e-mail Epson with your questions.

#### Speak to a Support Representative

Dial: (562) 276-1300 (U.S.), or (905) 709-9475 (Canada), 6 am to 6 pm, Pacific Time, Monday through Friday. Days and hours of support are subject to change without notice. Toll or long distance charges may apply.

Before you call Epson for support, please have the following information ready:

- Product name
- Product serial number
- Proof of purchase (such as a store receipt) and date of purchase
- Computer configuration
- Description of the problem

**Note:**

For help using any other software on your system, see the documentation for that software for technical support information.

#### Purchase Supplies and Accessories

You can purchase genuine Epson ink cartridges, ribbon cartridges, paper, and accessories from an Epson authorized reseller. To find the nearest reseller, call 800-GO-EPSON (800-463-7766). Or you can purchase online at <https://www.epsonstore.com> (U.S. sales) or <https://www.epson.ca> (Canadian sales).

### Help for Users in Europe

Check your **Pan-European Warranty Document** for information on how to contact Epson support.

### Help for Users in Taiwan

Contacts for information, support, and services are:

#### World Wide Web (<https://www.epson.com.tw>)

Information on product specifications, drivers for download, and products enquiry are available.

#### Epson HelpDesk (Phone: +0800212873)

Our HelpDesk team can help you with the following over the phone:

- Sales enquiries and product information
- Product usage questions or problems
- Enquiries on repair service and warranty

#### Repair service center:

Telephone number	Fax number	Address
02-23416969	02-23417070	No.20, Beiping E. Rd., Zhongzheng Dist., Taipei City 100, Taiwan
02-27491234	02-27495955	1F., No.16, Sec. 5, Nanjing E. Rd., Songshan Dist., Taipei City 105, Taiwan
02-32340688	02-32340699	No.1, Ln. 359, Sec. 2, Zhongshan Rd., Zhonghe City, Taipei County 235, Taiwan
039-605007	039-600969	No.342-1, Guangrong Rd., Luodong Township, Yilan County 265, Taiwan
038-312966	038-312977	No.87, Guolian 2nd Rd., Hualien City, Hualien County 970, Taiwan
03-4393119	03-4396589	5F., No.2, Nandong Rd., Pingzhen City, Taoyuan County 32455, Taiwan (R.O.C.)

## Where To Get Help

Telephone number	Fax number	Address
03-5325077	03-5320092	1F., No.9, Ln. 379, Sec. 1, Jingguo Rd., North Dist., Hsinchu City 300, Taiwan
04-23011502	04-23011503	3F., No.30, Dahe Rd., West Dist., Taichung City 40341, Taiwan (R.O.C.)
04-23805000	04-23806000	No.530, Sec. 4, Henan Rd., Nantun Dist., Taichung City 408, Taiwan
05-2784222	05-2784555	No.463, Zhongxiao Rd., East Dist., Chiayi City 600, Taiwan
06-2221666	06-2112555	No.141, Gongyuan N. Rd., North Dist., Tainan City 704, Taiwan
07-5520918	07-5540926	1F., No.337, Minghua Rd., Gushan Dist., Kaohsiung City 804, Taiwan
07-3222445	07-3218085	No.51, Shandong St., Sanmin Dist., Kaohsiung City 807, Taiwan
08-7344771	08-7344802	1F., No.113, Shengli Rd., Pingtung City, Pingtung County 900, Taiwan

## Help for Users in Australia/New Zealand

Epson Australia/New Zealand wishes to provide you with a high level of customer service. In addition to your product documentation, we provide the following sources for obtaining information:

### Your Dealer

Don't forget that your dealer can often help identify and resolve problems. The dealer should always be the first call for advise on problems; they can often solve problems quickly and easily as well as give advise on the next step to take.

## Internet URL

### Australia

<https://www.epson.com.au>

### New Zealand

<https://www.epson.co.nz>

Access the Epson Australia/New Zealand World Wide Web pages.

The site provides a download area for drivers, Epson contact points, new product information and technical support (e-mail).

## Epson Helpdesk

Epson Helpdesk is provided as a final backup to make sure our clients have access to advice. Operators on the Helpdesk can aid you in installing, configuring and operating your Epson product. Our Pre-sales Helpdesk staff can provide literature on new Epson products and advise where the nearest dealer or service agent is located. Many types of queries are answered here.

The Helpdesk numbers are:

Australia Phone: 1300 361 054

Fax: (02) 8899 3789

New Zealand Phone: 0800 237 766

We encourage you to have all the relevant information on hand when you ring. The more information you prepare, the faster we can help solve the problem. This information includes your Epson product documentation, type of computer, operating system, application programs, and any information you feel is required.

## Help for Users in Singapore

Sources of information, support, and services available from Epson Singapore are:

### World Wide Web

<https://www.epson.com.sg>

Information on product specifications, drivers for download, Frequently Asked Questions (FAQ), Sales Enquiries, and Technical Support via e-mail are available.



## Where To Get Help

### Epson HelpDesk (Phone: (65) 6586 3111)

Our HelpDesk team can help you with the following over the phone:

- Sales enquiries and product information
- Product usage questions or problems
- Enquiries on repair service and warranty

### Help for Users in Thailand

Contacts for information, support, and services are:

#### World Wide Web (<https://www.epson.co.th>)

Information on product specifications, drivers for download, Frequently Asked Questions (FAQ), and e-mail are available.

#### Epson Hotline (Phone: (66)2685-9899)

Our Hotline team can help you with the following over the phone:

- Sales enquiries and product information
- Product usage questions or problems
- Enquiries on repair service and warranty

### Help for Users in Vietnam

Contacts for information, support, and services are:

Epson Hotline (Phone): 84-8-823-9239

Service Center: 80 Truong Dinh Street,  
District 1, Hochiminh City  
Vietnam

### Help for Users in Indonesia

Contacts for information, support, and services are:

### World Wide Web (<https://www.epson.co.id>)

- Information on product specifications, drivers for download
- Frequently Asked Questions (FAQ), Sales Enquiries, questions through e-mail

#### Epson Hotline

- Sales enquiries and product information
- Technical support
  - Phone (62) 21-572 4350
  - Fax (62) 21-572 4357

#### Epson Service Center

Jakarta	Mangga Dua Mall 3rd floor No 3A/B Jl. Arteri Mangga Dua, Jakarta  Phone/Fax: (62) 21-62301104
Bandung	Lippo Center 8th floor Jl. Gatot Subroto No.2 Bandung  Phone/Fax: (62) 22-7303766
Surabaya	Hitech Mall It IIB No. 12 Jl. Kusuma Bangsa 116 – 118 Surabaya  Phone: (62) 31-5355035 Fax: (62)31-5477837
Yogyakarta	Hotel Natour Garuda Jl. Malioboro No. 60 Yogyakarta  Phone: (62) 274-565478
Medan	Wisma HSBC 4th floor Jl. Diponegoro No. 11 Medan  Phone/Fax: (62) 61-4516173

## Where To Get Help

Makassar MTC Karebosi Lt. Ill Kav. P7-8  
 Jl. Ahmad Yani No.49  
 Makassar

Phone: (62)411-350147/411-350148

---

## Help for Users in Hong Kong

To obtain technical support as well as other after-sales services, users are welcome to contact Epson Hong Kong Limited.

### Internet Home Page

Epson Hong Kong has established a local home page in both Chinese and English on the Internet to provide users with the following information:

- Product information
- Answers to Frequently Asked Questions (FAQs)
- Latest versions of Epson product drivers

Users can access our World Wide Web home page at:

<https://www.epson.com.hk>

### Technical Support Hotline

You can also contact our technical staff at the following telephone and fax numbers:

Phone: (852) 2827-8911

Fax: (852) 2827-4383

---

## Help for Users in Malaysia

Contacts for information, support, and services are:

### World Wide Web

<https://www.epson.com.my>

- Information on product specifications, drivers for download
- Frequently Asked Questions (FAQ), Sales Enquiries, questions through e-mail

## Epson Trading (M) Sdn. Bhd.

Head Office.

Phone: 603-56288288

Fax: 603-56288388/399

### Epson Helpdesk

- Sales enquiries and product information (Infoline)  
 Phone: 603-56288222
- Enquiries on repair services & warranty, product usage and technical support (Techline)  
 Phone: 603-56288333

---

## Help for Users in India

Contacts for information, support, and services are:

### World Wide Web

<https://www.epson.co.in>

Information on product specifications, drivers for download, and products enquiry are available.

### Epson India Head Office - Bangalore

Phone: 080-30515000

Fax: 30515005

### Epson India Regional Offices:

Location	Telephone number	Fax number
Mumbai	022-28261515 / 16/17	022-28257287
Delhi	011-30615000	011-30615005
Chennai	044-30277500	044-30277575
Kolkata	033-22831589 / 90	033-22831591
Hyderabad	040-66331738/ 39	040-66328633

## Where To Get Help

Location	Telephone number	Fax number
Cochin	0484-2357950	0484-2357950
Coimbatore	0422-2380002	NA
Pune	020-30286000 / 30286001 /30286002	020-30286000
Ahmedabad	079-26407176 / 77	079-26407347

- Enquiries on repair service and warranty

## Helpline

For Service, Product info or to order a cartridge -  
18004250011 (9AM - 9PM) - This is a Toll-free number.

For Service (CDMA & Mobile Users) - 3900 1600 (9AM  
- 6PM) Prefix local STD code

## Help for Users in the Philippines

To obtain technical support as well as other after sales services, users are welcome to contact the Epson Philippines Corporation at the telephone and fax numbers and e-mail address below:

Trunk Line: (63-2) 706 2609

Fax: (63-2) 706 2665

Helpdesk (63-2) 706 2625  
Direct Line:

E-mail: [epchelpdesk@epc.epson.com.ph](mailto:epchelpdesk@epc.epson.com.ph)

### World Wide Web

(<https://www.epson.com.ph>)

Information on product specifications, drivers for download, Frequently Asked Questions (FAQ), and E-mail Enquiries are available.

**Toll-Free No. 1800-1069-EPSON(37766)**

Our Hotline team can help you with the following over the phone:

- Sales enquiries and product information
- Product usage questions or problems

## Software License Terms

---

# Software License Terms

---

## Open Source Software Licenses

---

### Bonjour

This printer product includes the open source software programs which apply the Apple Public Source License Version 1.2 or its latest version ("Bonjour Programs").

We provide the source code of the Bonjour Programs pursuant to the Apple Public Source License Version 1.2 or its latest version until five (5) years after the discontinuation of same model of this printer product. If you desire to receive the source code of the Bonjour Programs, please see the "Contacting Customer Support" in Appendix or Printing Guide of this User's Guide, and contact the customer support of your region.

You can redistribute Bonjour Programs and/or modify it under the terms of the Apple Public Source License Version 1.2 or its latest version.

These Bonjour Programs are WITHOUT ANY WARRANTY; without even the implied warranty of MERCHANTABILITY AND FITNESS FOR A PARTICULAR PURPOSE.

The Apple Public Source License Version 1.2 is as follows. You also can see the Apple Public Source License Version 1.2 at <http://www.opensource.apple.com/apsl/>.

APPLE PUBLIC SOURCE LICENSE  
Version 2.0 - August 6, 2003

1. General; Definitions. This License applies to any program or other work which Apple Computer, Inc. ("Apple") makes publicly available and which contains a notice placed by Apple identifying such program or work as "Original Code" and stating that it is subject to the terms of this Apple Public Source License version 2.0 ("License"). As used in this License:

1.1 "Applicable Patent Rights" mean: (a) in the case where Apple is the grantor of rights, (i) claims of patents that are now or hereafter acquired, owned by or assigned to Apple and (ii) that cover subject matter contained in the Original Code, but only to the extent necessary to use, reproduce and/or distribute the Original Code without infringement; and (b) in the case where You are the grantor of rights, (i) claims of patents that are now or hereafter acquired, owned by or assigned to You and (ii) that cover subject matter in Your Modifications, taken alone or in combination with Original Code.

1.2 "Contributor" means any person or entity that creates or contributes to the creation of Modifications.

1.3 "Covered Code" means the Original Code, Modifications, the combination of Original Code and any Modifications, and/or any respective portions thereof.

1.4 "Externally Deploy" means: (a) to sublicense, distribute or otherwise make Covered Code available, directly or indirectly, to anyone other than You; and/or (b) to use Covered Code, alone or as part of a Larger Work, in any way to provide a service, including but not limited to delivery of content, through electronic communication with a client other than You.

1.5 "Larger Work" means a work which combines Covered Code or portions thereof with code not governed by the terms of this License.

## Software License Terms

1.6 "Modifications" mean any addition to, deletion from, and/or change to, the substance and/or structure of the Original Code, any previous Modifications, the combination of Original Code and any previous Modifications, and/or any respective portions thereof. When code is released as a series of files, a Modification is: (a) any addition to or deletion from the contents of a file containing Covered Code; and/or (b) any new file or other representation of computer program statements that contains any part of Covered Code.

1.7 "Original Code" means (a) the Source Code of a program or other work as originally made available by Apple under this License, including the Source Code of any updates or upgrades to such programs or works made available by Apple under this License, and that has been expressly identified by Apple as such in the header file(s) of such work; and (b) the object code compiled from such Source Code and originally made available by Apple under this License

1.8 "Source Code" means the human readable form of a program or other work that is suitable for making modifications to it, including all modules it contains, plus any associated interface definition files, scripts used to control compilation and installation of an executable (object code).

1.9 "You" or "Your" means an individual or a legal entity exercising rights under this License. For legal entities, "You" or "Your" includes any entity which controls, is controlled by, or is under common control with, You, where "control" means (a) the power, direct or indirect, to cause the direction or management of such entity, whether by contract or otherwise, or (b) ownership of fifty percent (50%) or more of the outstanding shares or beneficial ownership of such entity.

2. Permitted Uses; Conditions & Restrictions. Subject to the terms and conditions of this License, Apple hereby grants You, effective on the date You accept this License and download the Original Code, a world-wide, royalty-free, non-exclusive license, to the extent of Apple's Applicable Patent Rights and copyrights covering the Original Code, to do the following:

2.1 Unmodified Code. You may use, reproduce, display, perform, internally distribute within Your organization, and Externally Deploy verbatim, unmodified copies of the Original Code, for commercial or non-commercial purposes, provided that in each instance:

(a) You must retain and reproduce in all copies of Original Code the copyright and other proprietary notices and disclaimers of Apple as they appear in the Original Code, and keep intact all notices in the Original Code that refer to this License; and

(b) You must include a copy of this License with every copy of Source Code of Covered Code and documentation You distribute or Externally Deploy, and You may not offer or impose any terms on such Source Code that alter or restrict this License or the recipients' rights hereunder, except as permitted under Section 6.

2.2 Modified Code. You may modify Covered Code and use, reproduce, display, perform, internally distribute within Your organization, and Externally Deploy Your Modifications and Covered Code, for commercial or non-commercial purposes, provided that in each instance You also meet all of these conditions:

(a) You must satisfy all the conditions of Section 2.1 with respect to the Source Code of the Covered Code;

(b) You must duplicate, to the extent it does not already exist, the notice in Exhibit A in each file of the Source Code of all Your Modifications, and cause the modified files to carry prominent notices stating that You changed the files and the date of any change; and

(c) If You Externally Deploy Your Modifications, You must make Source Code of all Your Externally Deployed Modifications either available to those to whom You have Externally Deployed Your Modifications, or publicly available. Source Code of Your Externally Deployed Modifications must be released under the terms set forth in this License, including the license grants set forth in Section 3 below, for as long as you Externally Deploy the Covered Code or twelve (12) months from the date of initial External Deployment, whichever is longer. You should preferably distribute the Source Code of Your Externally Deployed Modifications electronically (e.g. download from a web site).

## Software License Terms

2.3 Distribution of Executable Versions. In addition, if You Externally Deploy Covered Code (Original Code and/or Modifications) in object code, executable form only, You must include a prominent notice, in the code itself as well as in related documentation, stating that Source Code of the Covered Code is available under the terms of this License with information on how and where to obtain such Source Code.

2.4 Third Party Rights. You expressly acknowledge and agree that although Apple and each Contributor grants the licenses to their respective portions of the Covered Code set forth herein, no assurances are provided by Apple or any Contributor that the Covered Code does not infringe the patent or other intellectual property rights of any other entity. Apple and each Contributor disclaim any liability to You for claims brought by any other entity based on infringement of intellectual property rights or otherwise. As a condition to exercising the rights and licenses granted hereunder, You hereby assume sole responsibility to secure any other intellectual property rights needed, if any. For example, if a third party patent license is required to allow You to distribute the Covered Code, it is Your responsibility to acquire that license before distributing the Covered Code.

3. Your Grants. In consideration of, and as a condition to, the licenses granted to You under this License, You hereby grant to any person or entity receiving or distributing Covered Code under this License a non-exclusive, royalty-free, perpetual, irrevocable license, under Your Applicable Patent Rights and other intellectual property rights (other than patent) owned or controlled by You, to use, reproduce, display, perform, modify, sublicense, distribute and Externally Deploy Your Modifications of the same scope and extent as Apple's licenses under Sections 2.1 and 2.2 above.

4. Larger Works. You may create a Larger Work by combining Covered Code with other code not governed by the terms of this License and distribute the Larger Work as a single product. In each such instance, You must make sure the requirements of this License are fulfilled for the Covered Code or any portion thereof.

5. Limitations on Patent License. Except as expressly stated in Section 2, no other patent rights, express or implied, are granted by Apple herein. Modifications and/or Larger Works may require additional patent licenses from Apple which Apple may grant in its sole discretion.

6. Additional Terms. You may choose to offer, and to charge a fee for, warranty, support, indemnity or liability obligations and/or other rights consistent with the scope of the license granted herein ("Additional Terms") to one or more recipients of Covered Code. However, You may do so only on Your own behalf and as Your sole responsibility, and not on behalf of Apple or any Contributor. You must obtain the recipient's agreement that any such Additional Terms are offered by You alone, and You hereby agree to indemnify, defend and hold Apple and every Contributor harmless for any liability incurred by or claims asserted against Apple or such Contributor by reason of any such Additional Terms.

7. Versions of the License. Apple may publish revised and/or new versions of this License from time to time. Each version will be given a distinguishing version number. Once Original Code has been published under a particular version of this License, You may continue to use it under the terms of that version. You may also choose to use such Original Code under the terms of any subsequent version of this License published by Apple. No one other than Apple has the right to modify the terms applicable to Covered Code created under this License.

## Software License Terms

8. NO WARRANTY OR SUPPORT. The Covered Code may contain in whole or in part pre-release, untested, or not fully tested works. The Covered Code may contain errors that could cause failures or loss of data, and may be incomplete or contain inaccuracies. You expressly acknowledge and agree that use of the Covered Code, or any portion thereof, is at Your sole and entire risk. THE COVERED CODE IS PROVIDED "AS IS" AND WITHOUT WARRANTY, UPGRADES OR SUPPORT OF ANY KIND AND APPLE AND APPLE'S LICENSOR(S) (COLLECTIVELY REFERRED TO AS "APPLE" FOR THE PURPOSES OF SECTIONS 8 AND 9) AND ALL CONTRIBUTORS EXPRESSLY DISCLAIM ALL WARRANTIES AND/OR CONDITIONS, EXPRESS OR IMPLIED, INCLUDING, BUT NOT LIMITED TO, THE IMPLIED WARRANTIES AND/OR CONDITIONS OF MERCHANTABILITY, OF SATISFACTORY QUALITY, OF FITNESS FOR A PARTICULAR PURPOSE, OF ACCURACY, OF QUIET ENJOYMENT, AND NONINFRINGEMENT OF THIRD PARTY RIGHTS. APPLE AND EACH CONTRIBUTOR DOES NOT WARRANT AGAINST INTERFERENCE WITH YOUR ENJOYMENT OF THE COVERED CODE, THAT THE FUNCTIONS CONTAINED IN THE COVERED CODE WILL MEET YOUR REQUIREMENTS, THAT THE OPERATION OF THE COVERED CODE WILL BE UNINTERRUPTED OR ERROR-FREE, OR THAT DEFECTS IN THE COVERED CODE WILL BE CORRECTED. NO ORAL OR WRITTEN INFORMATION OR ADVICE GIVEN BY APPLE, AN APPLE AUTHORIZED REPRESENTATIVE OR ANY CONTRIBUTOR SHALL CREATE A WARRANTY. You acknowledge that the Covered Code is not intended for use in the operation of nuclear facilities, aircraft navigation, communication systems, or air traffic control machines in which case the failure of the Covered Code could lead to death, personal injury, or severe physical or environmental damage.

9. LIMITATION OF LIABILITY. TO THE EXTENT NOT PROHIBITED BY LAW, IN NO EVENT SHALL APPLE OR ANY CONTRIBUTOR BE LIABLE FOR ANY INCIDENTAL, SPECIAL, INDIRECT OR CONSEQUENTIAL DAMAGES ARISING OUT OF OR RELATING TO THIS LICENSE OR YOUR USE OR INABILITY TO USE THE COVERED CODE, OR ANY PORTION THEREOF, WHETHER UNDER A THEORY OF CONTRACT, WARRANTY, TORT (INCLUDING NEGLIGENCE), PRODUCTS LIABILITY OR OTHERWISE, EVEN IF APPLE OR SUCH CONTRIBUTOR HAS BEEN ADVISED OF THE POSSIBILITY OF SUCH DAMAGES AND NOTWITHSTANDING THE FAILURE OF ESSENTIAL PURPOSE OF ANY REMEDY. SOME JURISDICTIONS DO NOT ALLOW THE LIMITATION OF LIABILITY OF INCIDENTAL OR CONSEQUENTIAL DAMAGES, SO THIS LIMITATION MAY NOT APPLY TO YOU. In no event shall Apple's total liability to You for all damages (other than as may be required by applicable law) under this License exceed the amount of fifty dollars (\$50.00).

10. Trademarks. This License does not grant any rights to use the trademarks or trade names "Apple", "Apple Computer", "Mac", "Mac OS", "QuickTime", "QuickTime Streaming Server" or any other trademarks, service marks, logos or trade names belonging to Apple (collectively "Apple Marks") or to any trademark, service mark, logo or trade name belonging to any Contributor. You agree not to use any Apple Marks in or as part of the name of products derived from the Original Code or to endorse or promote products derived from the Original Code other than as expressly permitted by and in strict compliance at all times with Apple's third party trademark usage guidelines which are posted at <http://www.apple.com/legal/guidelinesfor3rdparties.html>.

11. Ownership. Subject to the licenses granted under this License, each Contributor retains all rights, title and interest in and to any Modifications made by such Contributor. Apple retains all rights, title and interest in and to the Original Code and any Modifications made by or on behalf of Apple ("Apple Modifications"), and such Apple Modifications will not be automatically subject to this License. Apple may, at its sole discretion, choose to license such Apple Modifications under this License, or on different terms from those contained in this License or may choose not to license them at all.

12. Termination.

12.1 Termination. This License and the rights granted hereunder will terminate:

(a) automatically without notice from Apple if You fail to comply with any term(s) of this License and fail to cure such breach within 30 days of becoming aware of such breach;

(b) immediately in the event of the circumstances described in Section 13.5(b); or

## Software License Terms

(c) automatically without notice from Apple if You, at any time during the term of this License, commence an action for patent infringement against Apple; provided that Apple did not first commence an action for patent infringement against You in that instance.

12.2 Effect of Termination. Upon termination, You agree to immediately stop any further use, reproduction, modification, sublicensing and distribution of the Covered Code. All sublicenses to the Covered Code which have been properly granted prior to termination shall survive any termination of this License. Provisions which, by their nature, should remain in effect beyond the termination of this License shall survive, including but not limited to Sections 3, 5, 8, 9, 10, 11, 12.2 and 13. No party will be liable to any other for compensation, indemnity or damages of any sort solely as a result of terminating this License in accordance with its terms, and termination of this License will be without prejudice to any other right or remedy of any party.

### 13. Miscellaneous.

13.1 Government End Users. The Covered Code is a "commercial item" as defined in FAR 2.101. Government software and technical data rights in the Covered Code include only those rights customarily provided to the public as defined in this License. This customary commercial license in technical data and software is provided in accordance with FAR 12.211 (Technical Data) and 12.212 (Computer Software) and, for Department of Defense purchases, DFAR 252.227-7015 (Technical Data -- Commercial Items) and 227.7202-3 (Rights in Commercial Computer Software or Computer Software Documentation). Accordingly, all U.S. Government End Users acquire Covered Code with only those rights set forth herein.

13.2 Relationship of Parties. This License will not be construed as creating an agency, partnership, joint venture or any other form of legal association between or among You, Apple or any Contributor, and You will not represent to the contrary, whether expressly, by implication, appearance or otherwise.

13.3 Independent Development. Nothing in this License will impair Apple's right to acquire, license, develop, have others develop for it, market and/or distribute technology or products that perform the same or similar functions as, or otherwise compete with, Modifications, Larger Works, technology or products that You may develop, produce, market or distribute.

13.4 Waiver; Construction. Failure by Apple or any Contributor to enforce any provision of this License will not be deemed a waiver of future enforcement of that or any other provision. Any law or regulation which provides that the language of a contract shall be construed against the drafter will not apply to this License.

13.5 Severability. (a) If for any reason a court of competent jurisdiction finds any provision of this License, or portion thereof, to be unenforceable, that provision of the License will be enforced to the maximum extent permissible so as to effect the economic benefits and intent of the parties, and the remainder of this License will continue in full force and effect. (b) Notwithstanding the foregoing, if applicable law prohibits or restricts You from fully and/or specifically complying with Sections 2 and/or 3 or prevents the enforceability of either of those Sections, this License will immediately terminate and You must immediately discontinue any use of the Covered Code and destroy all copies of it that are in your possession or control.

13.6 Dispute Resolution. Any litigation or other dispute resolution between You and Apple relating to this License shall take place in the Northern District of California, and You and Apple hereby consent to the personal jurisdiction of, and venue in, the state and federal courts within that District with respect to this License. The application of the United Nations Convention on Contracts for the International Sale of Goods is expressly excluded.

13.7 Entire Agreement; Governing Law. This License constitutes the entire agreement between the parties with respect to the subject matter hereof. This License shall be governed by the laws of the United States and the State of California, except that body of California law concerning conflicts of law.

Where You are located in the province of Quebec, Canada, the following clause applies: The parties hereby confirm that they have requested that this License and all related documents be drafted in English.

Les parties ont exigé que le présent contrat et tous les documents connexes soient rédigés en anglais.



**Software License Terms**

EXHIBIT A.

"Portions Copyright (c) 1999-2003 Apple Computer, Inc. All Rights Reserved.

This file contains Original Code and/or Modifications of Original Code as defined in and that are subject to the Apple Public Source License Version 2.0 (the 'License'). You may not use this file except in compliance with the License. Please obtain a copy of the License at <http://www.opensource.apple.com/apsl/> and read it before using this file.

The Original Code and all software distributed under the License are distributed on an 'AS IS' basis, WITHOUT WARRANTY OF ANY KIND, EITHER EXPRESS OR IMPLIED, AND APPLE HEREBY DISCLAIMS ALL SUCH WARRANTIES, INCLUDING WITHOUT LIMITATION, ANY WARRANTIES OF MERCHANTABILITY, FITNESS FOR A PARTICULAR PURPOSE, QUIET ENJOYMENT OR NON-INFRINGEMENT. Please see the License for the specific language governing rights and limitations under the License."

---

**OpenSSL License/Original SSLeay License**

LICENSE ISSUES

=====

The OpenSSL toolkit stays under a double license, i.e. both the conditions of the OpenSSL License and the original SSLeay license apply to the toolkit.

See below for the actual license texts.

OpenSSL License

-----

/\* =====

\* Copyright (c) 1998-2017 The OpenSSL Project. All rights reserved.

\*

\* Redistribution and use in source and binary forms, with or without

\* modification, are permitted provided that the following conditions

\* are met:

\* 1. Redistributions of source code must retain the above copyright

\* notice, this list of conditions and the following disclaimer.

\*

\* 2. Redistributions in binary form must reproduce the above copyright

## Software License Terms

- \* notice, this list of conditions and the following disclaimer in
- \* the documentation and/or other materials provided with the
- \* distribution.
- \*
- \* 3. All advertising materials mentioning features or use of this
- \* software must display the following acknowledgment:
- \* "This product includes software developed by the OpenSSL Project
- \* for use in the OpenSSL Toolkit. (<http://www.openssl.org/>)"
- \*
- \* 4. The names "OpenSSL Toolkit" and "OpenSSL Project" must not be used to
- \* endorse or promote products derived from this software without
- \* prior written permission. For written permission, please contact
- \* [openssl-core@openssl.org](mailto:openssl-core@openssl.org).
- \*
- \* 5. Products derived from this software may not be called "OpenSSL"
- \* nor may "OpenSSL" appear in their names without prior written
- \* permission of the OpenSSL Project.
- \*
- \* 6. Redistributions of any form whatsoever must retain the following
- \* acknowledgment:
- \* "This product includes software developed by the OpenSSL Project
- \* for use in the OpenSSL Toolkit (<http://www.openssl.org/>)"
- \*
- \* THIS SOFTWARE IS PROVIDED BY THE OpenSSL PROJECT ``AS IS" AND ANY
- \* EXPRESSED OR IMPLIED WARRANTIES, INCLUDING, BUT NOT LIMITED TO, THE
- \* IMPLIED WARRANTIES OF MERCHANTABILITY AND FITNESS FOR A PARTICULAR
- \* PURPOSE ARE DISCLAIMED. IN NO EVENT SHALL THE OpenSSL PROJECT OR
- \* ITS CONTRIBUTORS BE LIABLE FOR ANY DIRECT, INDIRECT, INCIDENTAL,

**Software License Terms**

- \* SPECIAL, EXEMPLARY, OR CONSEQUENTIAL DAMAGES (INCLUDING, BUT
- \* NOT LIMITED TO, PROCUREMENT OF SUBSTITUTE GOODS OR SERVICES;
- \* LOSS OF USE, DATA, OR PROFITS; OR BUSINESS INTERRUPTION)
- \* HOWEVER CAUSED AND ON ANY THEORY OF LIABILITY, WHETHER IN CONTRACT,
- \* STRICT LIABILITY, OR TORT (INCLUDING NEGLIGENCE OR OTHERWISE)
- \* ARISING IN ANY WAY OUT OF THE USE OF THIS SOFTWARE, EVEN IF ADVISED
- \* OF THE POSSIBILITY OF SUCH DAMAGE.

=====

\*

- \* This product includes cryptographic software written by Eric Young
- \* (eay@cryptsoft.com). This product includes software written by Tim
- \* Hudson (tjh@cryptsoft.com).

\*

\* /

Original SSLeay License

-----

- /\* Copyright (C) 1995-1998 Eric Young (eay@cryptsoft.com)
- \* All rights reserved.
- \*
- \* This package is an SSL implementation written
- \* by Eric Young (eay@cryptsoft.com).
- \* The implementation was written so as to conform with Netscapes SSL.
- \*
- \* This library is free for commercial and non-commercial use as long as
- \* the following conditions are aheared to. The following conditions
- \* apply to all code found in this distribution, be it the RC4, RSA,
- \* lhash, DES, etc., code; not just the SSL code. The SSL documentation

## Software License Terms

- \* included with this distribution is covered by the same copyright terms
- \* except that the holder is Tim Hudson (tjh@cryptsoft.com).
- \*
- \* Copyright remains Eric Young's, and as such any Copyright notices in
- \* the code are not to be removed.
- \* If this package is used in a product, Eric Young should be given attribution
- \* as the author of the parts of the library used.
- \* This can be in the form of a textual message at program startup or
- \* in documentation (online or textual) provided with the package.
- \*
- \* Redistribution and use in source and binary forms, with or without
- \* modification, are permitted provided that the following conditions
- \* are met:
- \* 1. Redistributions of source code must retain the copyright
- \* notice, this list of conditions and the following disclaimer.
- \* 2. Redistributions in binary form must reproduce the above copyright
- \* notice, this list of conditions and the following disclaimer in the
- \* documentation and/or other materials provided with the distribution.
- \* 3. All advertising materials mentioning features or use of this software
- \* must display the following acknowledgement:
- \* "This product includes cryptographic software written by
- \* Eric Young (eay@cryptsoft.com)"
- \* The word 'cryptographic' can be left out if the routines from the library
- \* being used are not cryptographic related :-).
- \* 4. If you include any Windows specific code (or a derivative thereof) from
- \* the apps directory (application code) you must include an acknowledgement:
- \* "This product includes software written by Tim Hudson (tjh@cryptsoft.com)"
- \*

## Software License Terms

- \* THIS SOFTWARE IS PROVIDED BY ERIC YOUNG ``AS IS" AND
- \* ANY EXPRESS OR IMPLIED WARRANTIES, INCLUDING, BUT NOT LIMITED TO, THE
- \* IMPLIED WARRANTIES OF MERCHANTABILITY AND FITNESS FOR A PARTICULAR PURPOSE
- \* ARE DISCLAIMED. IN NO EVENT SHALL THE AUTHOR OR CONTRIBUTORS BE LIABLE
- \* FOR ANY DIRECT, INDIRECT, INCIDENTAL, SPECIAL, EXEMPLARY, OR CONSEQUENTIAL
- \* DAMAGES (INCLUDING, BUT NOT LIMITED TO, PROCUREMENT OF SUBSTITUTE GOODS
- \* OR SERVICES; LOSS OF USE, DATA, OR PROFITS; OR BUSINESS INTERRUPTION)
- \* HOWEVER CAUSED AND ON ANY THEORY OF LIABILITY, WHETHER IN CONTRACT, STRICT
- \* LIABILITY, OR TORT (INCLUDING NEGLIGENCE OR OTHERWISE) ARISING IN ANY WAY
- \* OUT OF THE USE OF THIS SOFTWARE, EVEN IF ADVISED OF THE POSSIBILITY OF
- \* SUCH DAMAGE.
- \*
- \* The licence and distribution terms for any publically available version or
- \* derivative of this code cannot be changed. i.e. this code cannot simply be
- \* copied and put under another distribution licence
- \* [including the GNU Public Licence.]
- \* /

## Other Software Licenses

---

### Info-ZIP copyright and license

This is version 2007-Mar-4 of the Info-ZIP license. The definitive version of this document should be available at <ftp://ftp.info-zip.org/pub/infozip/license.html> indefinitely and a copy at <http://www.info-zip.org/pub/infozip/license.html>.

Copyright © 1990-2007 Info-ZIP. All rights reserved.

For the purposes of this copyright and license, "Info-ZIP" is defined as the following set of individuals:

Mark Adler, John Bush, Karl Davis, Harald Denker, Jean-Michel Dubois, Jean-loup Gailly, Hunter Goatley, Ed Gordon, Ian Gorman, Chris Herborth, Dirk Haase, Greg Hartwig, Robert Heath, Jonathan Hudson, Paul Kienitz, David Kirschbaum, Johnny Lee, Onno van der Linden, Igor Mandrichenko, Steve P. Miller, Sergio Monesi, Keith Owens, George Petrov, Greg Roelofs, Kai Uwe Rommel, Steve Salisbury, Dave Smith, Steven M. Schweda, Christian Spieler, Cosmin Truta, Antoine Verheijen, Paul von Behren, Rich Wales, Mike White.

## Software License Terms

This software is provided "as is," without warranty of any kind, express or implied. In no event shall Info-ZIP or its contributors be held liable for any direct, indirect, incidental, special or consequential damages arising out of the use of or inability to use this software.

Permission is granted to anyone to use this software for any purpose, including commercial applications, and to alter it and redistribute it freely, subject to the above disclaimer and the following restrictions:

1. Redistributions of source code (in whole or in part) must retain the above copyright notice, definition, disclaimer, and this list of conditions.
2. Redistributions in binary form (compiled executables and libraries) must reproduce the above copyright notice, definition, disclaimer, and this list of conditions in documentation and/or other materials provided with the distribution. The sole exception to this condition is redistribution of a standard UnZipSFX binary (including SFXWiz) as part of a self-extracting archive; that is permitted without inclusion of this license, as long as the normal SFX banner has not been removed from the binary or disabled.
3. Altered versions--including, but not limited to, ports to new operating systems, existing ports with new graphical interfaces, versions with modified or added functionality, and dynamic, shared, or static library versions not from Info-ZIP--must be plainly marked as such and must not be misrepresented as being the original source or, if binaries, compiled from the original source. Such altered versions also must not be misrepresented as being Info-ZIP releases--including, but not limited to, labeling of the altered versions with the names "Info-ZIP" (or any variation thereof, including, but not limited to, different capitalizations), "Pocket UnZip," "WiZ" or "MacZip" without the explicit permission of Info-ZIP. Such altered versions are further prohibited from misrepresentative use of the Zip-Bugs or Info-ZIP e-mail addresses or the Info-ZIP URL(s), such as to imply Info-ZIP will provide support for the altered versions.
4. Info-ZIP retains the right to use the names "Info-ZIP," "Zip," "UnZip," "UnZipSFX," "WiZ," "Pocket UnZip," "Pocket Zip," and "MacZip" for its own source and binary releases.