



# SC-F6300 Series

# Operator's Guide

---

CMP0175-00 EN

## Copyrights and Trademarks

---

### ***Copyrights and Trademarks***

No part of this publication may be reproduced, stored in a retrieval system, or transmitted in any form or by any means, electronic, mechanical, photocopying, recording, or otherwise, without the prior written permission of Seiko Epson Corporation. The information contained herein is designed only for use with this Epson printer. Epson is not responsible for any use of this information as applied to other printers.

Neither Seiko Epson Corporation nor its affiliates shall be liable to the purchaser of this product or third parties for damages, losses, costs, or expenses incurred by the purchaser or third parties as a result of accident, misuse, or abuse of this product or unauthorized modifications, repairs, or alterations to this product, or (excluding the U.S.) failure to strictly comply with Seiko Epson Corporation's operating and maintenance instructions.

Seiko Epson Corporation shall not be liable for any damages or problems arising from the use of any options or any consumable products other than those designated as Original Epson Products or Epson Approved Products by Seiko Epson Corporation.

Seiko Epson Corporation shall not be held liable for any damage resulting from electromagnetic interference that occurs from the use of any interface cables other than those designated as Epson Approved Products by Seiko Epson Corporation.

EPSON, EPSON EXCEED YOUR VISION, EXCEED YOUR VISION and their logos are registered trademarks or trademarks of Seiko Epson Corporation.

Microsoft®, Windows® are registered trademarks of Microsoft Corporation.

Mac, macOS are registered trademarks of Apple Inc.

Intel® is a registered trademark of Intel Corporation.

Adobe and Reader are either registered trademarks or trademarks of Adobe Systems Incorporated in the United States and/or other countries.

YouTube® and the YouTube logo are registered trademarks or trademarks of YouTube, LLC.

*General Notice: Other product names used herein are for identification purposes only and may be trademarks of their respective owners. Epson disclaims any and all rights in those marks.*

© 2019 Seiko Epson Corporation. All rights reserved.

# Contents

## Copyrights and Trademarks

### Viewing Manuals

Meaning of Symbols. . . . . 4  
 Illustrations. . . . . 4  
 Video Manuals. . . . . 4

### Part Names

Front Section. . . . . 5  
 Slider. . . . . 5  
 Inside. . . . . 6  
 Roll paper adapter. . . . . 6

### Basic Operations

Notes on Handling Paper. . . . . 7  
 Notes on Loading Paper. . . . . 7  
 Loading and Removing the Roll Paper. . . . . 8  
     Attaching the Roll Paper Adapter. . . . . 8  
     Loading Roll Paper. . . . . 9  
     Cutting the roll paper. . . . . 10  
     Removing the roll paper. . . . . 11  
 Settings for Loaded Paper. . . . . 12  
 Replacing Paper. . . . . 13

### Maintenance

When to Perform Various Maintenance Operations. . . . . 14  
     Regular maintenance. . . . . 14  
     Refilling and Replacing Consumables. . . . . 16  
     Performing maintenance when print quality declines. . . . . 16  
 What You'll Need. . . . . 19  
 Precautions Regarding Maintenance. . . . . 19  
 Refilling ink. . . . . 20  
     Time Period for Ink Refills. . . . . 20  
     Procedure for Ink Refills. . . . . 21  
 Disposing of Waste Ink. . . . . 27  
     Preparing and Replacement Timing. . . . . 27  
     Waste Ink Counter. . . . . 27  
     Replacing the Waste Ink Bottle. . . . . 27  
 Clearing clogged nozzles. . . . . 28  
     Printing a Check Pattern. . . . . 29  
     Head Cleaning. . . . . 29

Handling Used Consumables. . . . . 30





### Information on Maintenance Items

Ink packs. . . . . 31  
 Others. . . . . 32

Viewing Manuals

# Viewing Manuals

## Meaning of Symbols

 <b>Warning:</b>	Warnings must be followed to avoid serious bodily injury.
 <b>Caution:</b>	Cautions must be followed to avoid bodily injury.
 <b>Important:</b>	Important must be followed to avoid damage to this product.
<b>Note:</b>	Notes contain useful or additional information on the operation of this product.
	Indicates related reference content.

## Illustrations

The illustrations may differ slightly from the model you are using. Please be aware of this when using the manual.

## Video Manuals

These video manuals are uploaded to YouTube and show you how to perform maintenance.

Click [Epson Video Manuals] from the top page of *Online Manual* to view the video manuals, or click the blue link below.

[Epson Video Manuals](#)

You can also follow the steps below to access YouTube.

- 1 Access YouTube (<https://youtube.com>).

- 2 Enter [Epson Video Manuals (LFP)] in the search bar at the top of the screen.
- 3 Click [Epson Video Manuals (LFP)] in the search results.
- 4 Select the video you want to view from the list for the model you are using.

If the subtitles are not displayed when you play the video, click the subtitles icon shown in the image below.

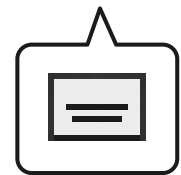

Part Names

# Part Names

## Front Section

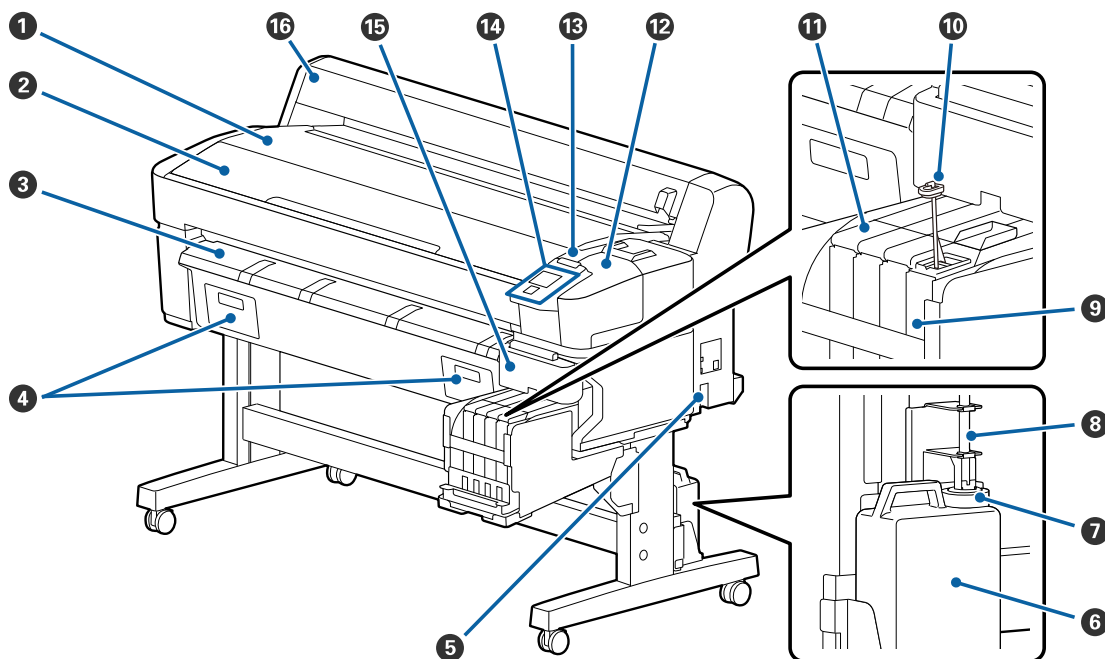

- |                             |                  |                     |
|-----------------------------|------------------|---------------------|
| ① Roll rest                 | ⑦ Stopper        | ⑫ Maintenance cover |
| ② Printer cover             | ⑧ Waste ink tube | ⑬ Alert lamp        |
| ③ Paper eject guide         | ⑨ Ink tank       | ⑭ Control panel     |
| ④ Not used for this printer | ⑩ Stirring stick | ⑮ Side cover        |
| ⑤ AC inlet                  | ⑪ Slider         | ⑯ Roll paper cover  |
| ⑥ Waste Ink Bottle          |                  |                     |

## Slider

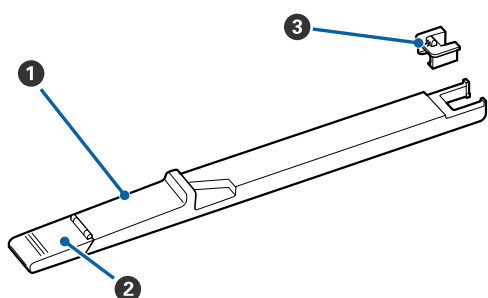

- ① Slider
- ② Ink inlet cover
- ③ Chip unit

Part Names

Inside

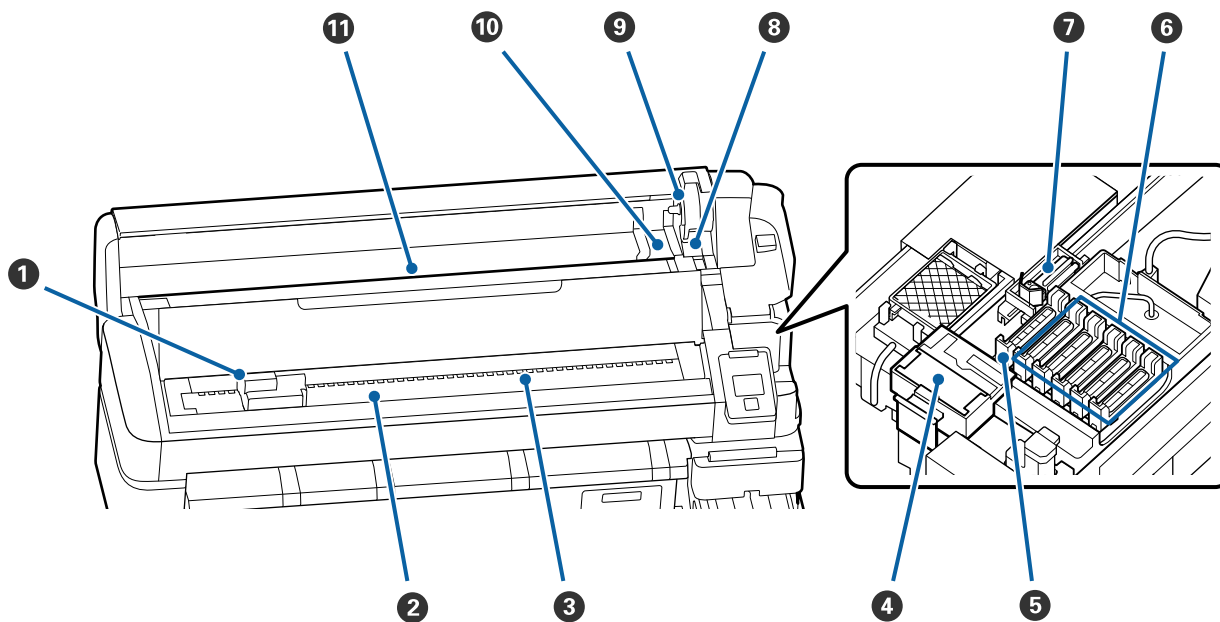

- ① Print head
- ② Platen
- ③ Rollers
- ④ Wiper cleaner
- ⑤ Suction caps
- ⑥ Anti-drying caps
- ⑦ Wiper
- ⑧ Roll lock lever
- ⑨ Adapter holder
- ⑩ Adapter guides
- ⑪ Paper slot

Roll paper adapter

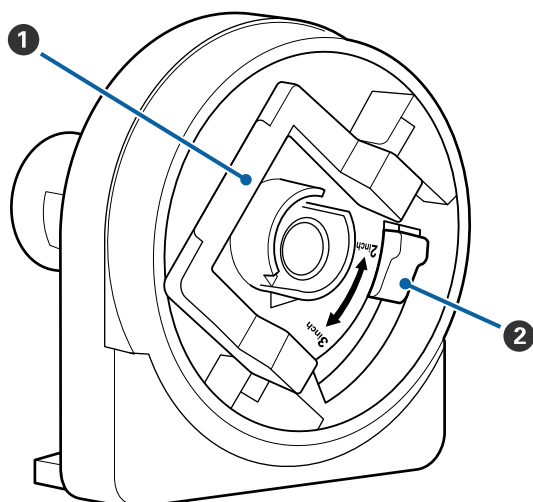

- ① Adapter lock lever
- ② Size lever

# Basic Operations

## Notes on Handling Paper

If the following points are not observed when handling paper, small amounts of dust and lint may stick to the paper surface and cause ink drops in the print results or cause the nozzles to clog.

**Do not place exposed paper directly on the floor.**

Paper should be rewound and inserted in its original packaging for storage.

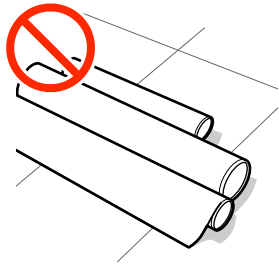

**Do not carry paper with the paper surface pressed against clothing.**

Handle paper in its individual packaging until just before loading the paper in the printer.

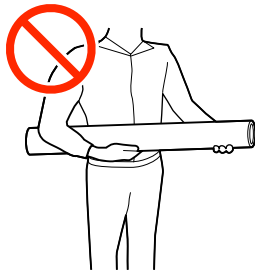

## Notes on Loading Paper



**Caution:**

*Do not rub your hands along the edges of the paper. The edges of the paper are sharp and can cause injury.*

**Load the paper just before printing.**

The pressure rollers may leave an impression on paper that is left in the printer. This can also cause wavy or curled paper resulting in paper feeding problems or the print head could be scratched.

**Do not load paper if the right and left edges are uneven.**

If paper is loaded and the right and left edges of the roll are uneven, paper feeding problems may cause the paper to move around during printing. Either rewind to align the edges or use a roll without any issues.

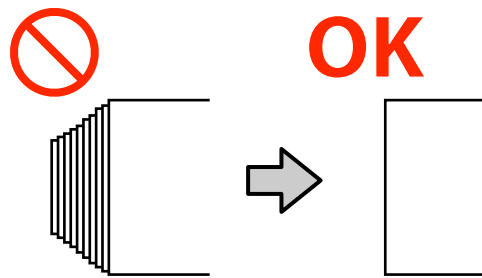

**Paper that cannot be used**

Do not use paper that is folded, wrinkled, scuffed, torn, or dirty. The paper could rise up and contact the print heads and damage them.

Do not use paper that is frayed at the ends of the roll, wrinkled, torn, and so on, as shown in the following image.



Basic Operations

# Loading and Removing the Roll Paper

Load roll paper after attaching the supplied roll paper adapters.

## Attaching the Roll Paper Adapter

- 1 Place roll paper on the roll rest on top of the printer.

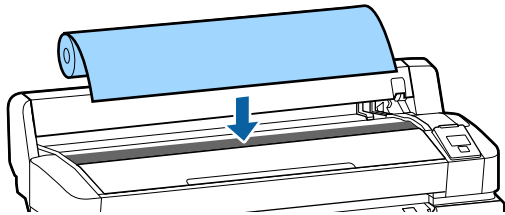

- 2 Move the size switch levers of the two supplied roll paper adapters in accordance with the roll-core size of the roll paper to be loaded.

3-inch core

2-inch core

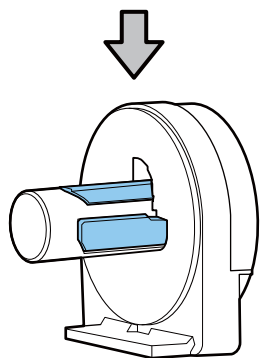
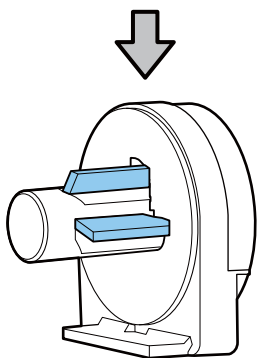
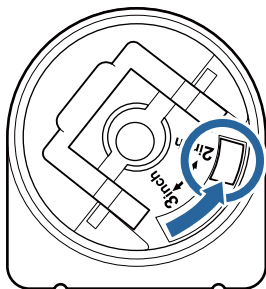
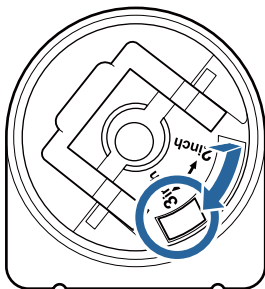

- 3 Raise the adapter lock lever to release the lock on each of the two roll paper adapters.

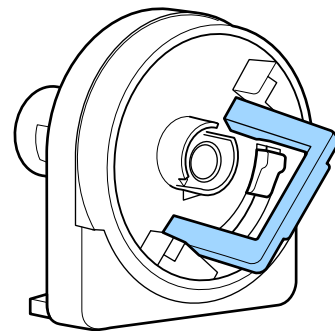
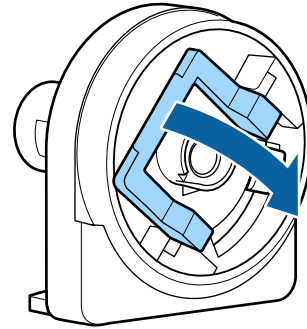

- 4 Raise the adapter lock lever to release the lock on each of the two roll paper adapters.

Press the adapters in until they are fully inserted in the roll, with no gaps.



- 5 Lower the lock levers to lock the adapters in place.

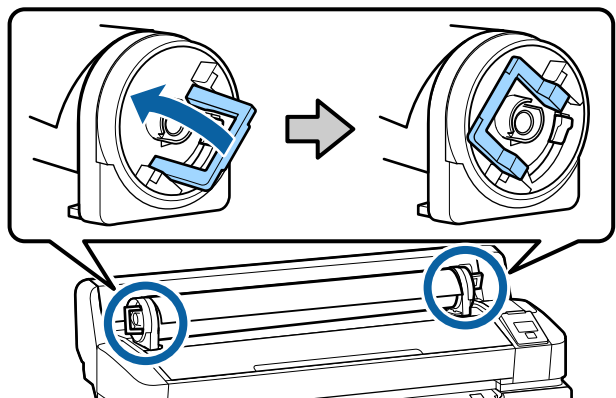



Basic Operations

### Loading Roll Paper

Buttons that are used in the following settings

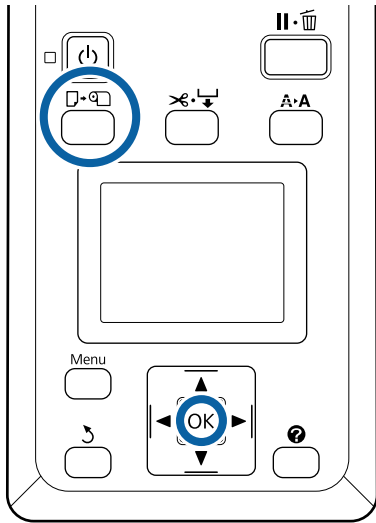

- 1 Check that **Press and load paper.** is displayed on the screen, and then open the roll paper cover.

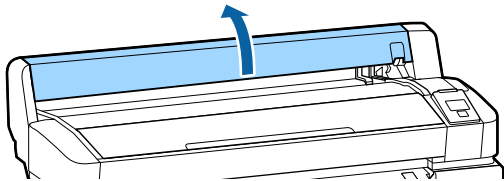

- 2 Confirm that the adapter holder lock lever is raised.

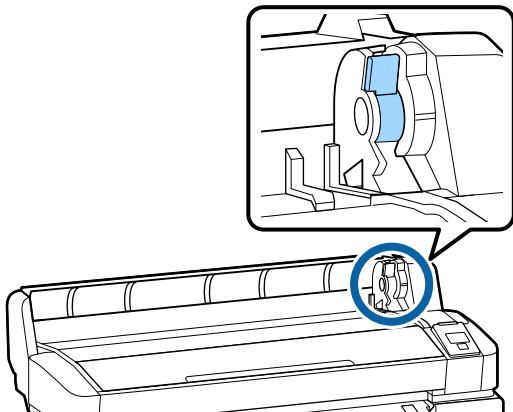

- 3 Slide the roll paper right until it contacts the adapter guide. Next, following the adapter guide, slide the roll slowly inside.

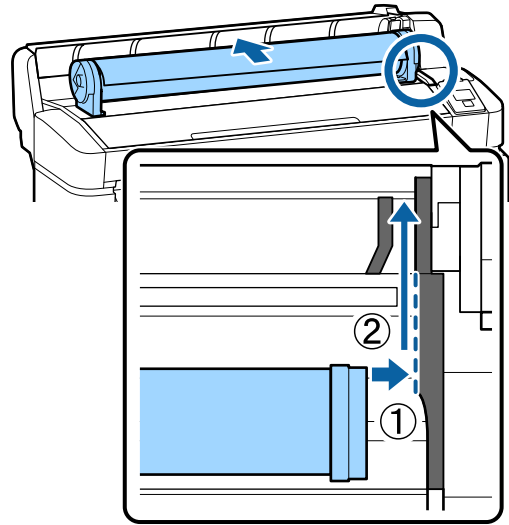

- 4 Press the button on the control panel. Confirm that **Roll Paper** is highlighted in the display and press the OK button.

- 5 Make sure that the roll paper is free of slack and the end is not frayed, insert it into the paper slot, and then pull it out from the front of the printer.

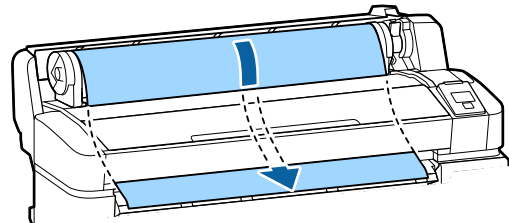

**Note:**

Do not touch the paper where it will be printed. After loading the roll paper, rotate the roll paper adapters as shown to feed the paper through.

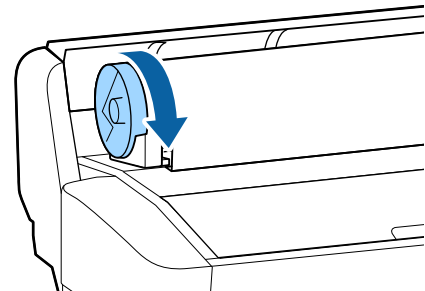

## Basic Operations

- 6** Lower the roll paper lock lever, and then press the OK button.

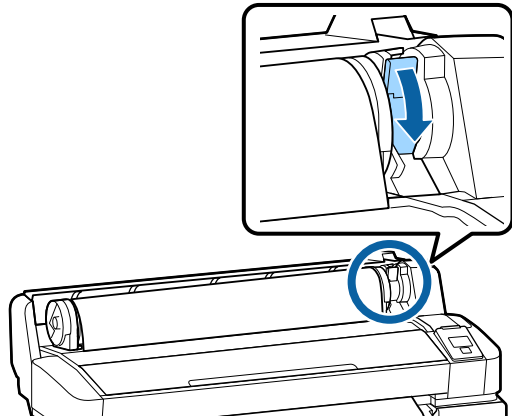

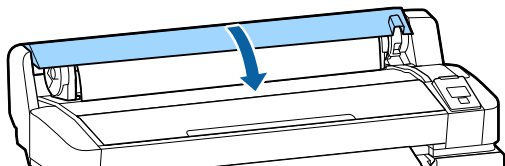

If the leading edge of the paper is not horizontal or not cut neatly, you can cut the edge of the roll paper with the built-in cutter by pressing the OK button, and then pressing the  button within five seconds.

- 7** Close the roll paper cover.



- 8** Check the paper type.

The previous settings for the paper type and amount remaining are displayed.

To print using the current settings, press the / buttons to highlight **Keep Settings Above**, and then press the OK button.

Failure to set the appropriate paper type could cause problems with print quality. See the following for details on paper type and amount remaining settings.

 [“Settings for Loaded Paper” on page 12](#)



## Cutting the roll paper

Either of the following two methods can be used to cut roll paper after printing.



- Auto Cut:**  
Cut the roll paper after printing each page automatically using the built-in cutter.

- Manual cut:**  
Press the  button to cut the paper using the built-in cutter. A cutline is printed for manual cutting and can be used as a guide when cutting paper using the built-in cutter.

### Note:

- It may take a while to cut the roll paper.
- Some of the roll paper may not be cut using the built-in cutter. Use a cutter sold at a store to cut the paper.  
Follow the steps below when using a third-party cutter.  
Press the  button. Keep the  button pressed to feed the paper so that the cut location is below the paper eject guide. Cut the paper using scissors or a third-party cutter.

## Setting methods

Use the /  buttons in the control panel to select the  tab and press the OK or Menu button. When the Setup menu is displayed, select **Printer Setup > Roll Paper Setup > Auto Cut > ON**, and then press the OK button. For manual cutting, select **OFF**. The default setting is **ON**.

## Manual cut method

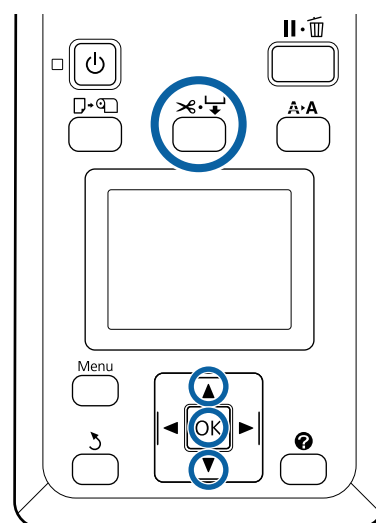

If **Auto Cut** is turned **OFF**, you can cut at any position via the following procedure after printing is complete.

Buttons that are used in the following settings



## Basic Operations

### Cutting paper manually using the built-in cutter

- 1 Press the  button. Viewing the interior of the printer without opening the printer cover, press the  button to align the cut location with the  mark on the right side of the printer's interior.

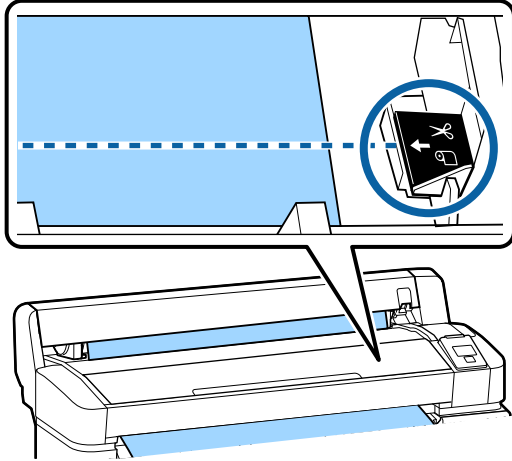

**Note:**

The minimum length of paper that can be cut with the built-in cutter is fixed at 60 to 127 mm and cannot be changed. If the cutting position is shorter than the shortest length above, the paper has to be automatically fed to that length thus a margin will have to be left. Cut off the margin with a cutter sold at a store.



- 2 Press the **OK** button.  
The paper is cut by the built-in cutter.

### Removing the roll paper

This section describes how to remove and store roll paper after printing. The pressure rollers may leave impressions on paper that is left in the printer.

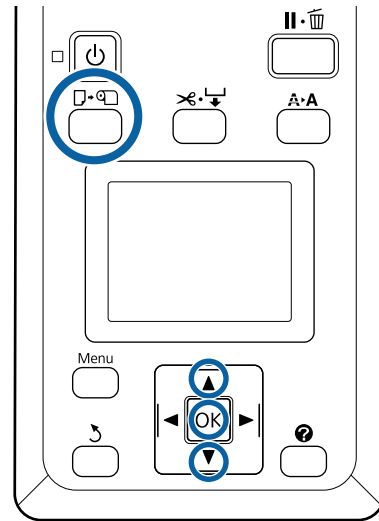
Buttons that are used in the following settings



- 1 Confirm that the printer is ready and press the  button.  
The Load/Remove Paper menu will be displayed.
- 2 Press the / buttons to highlight **Remove Paper** and press the **OK** button.

**Note:**

In order to perform accurate remaining roll paper management, we recommend opening the  tab and recording the amount of roll paper remaining when you replace the roll paper.

To perform Roll Paper Remaining, you must enter the length of the roll paper when the roll paper is set.

- 3 The paper will automatically be rewound.  
Once the paper is rewound, the printer will display **Press  and load paper.**

**Note:**

When the display shows **Turn roll paper adapter to wind up roll paper**, open the roll paper cover and rewind the paper by hand.

- 4 Open the roll paper cover.

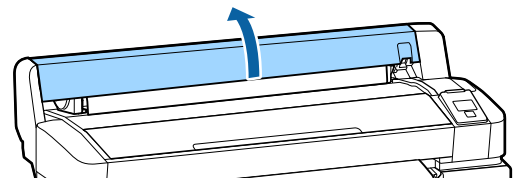

Basic Operations

- 5** Raise the roll lock lever.

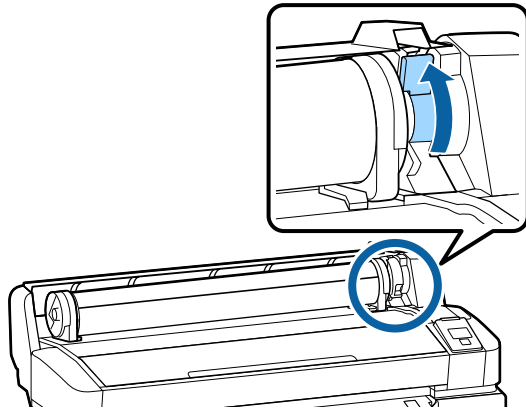

- 6** Holding the paper by the roll adapters, move the roll to the roll rest.

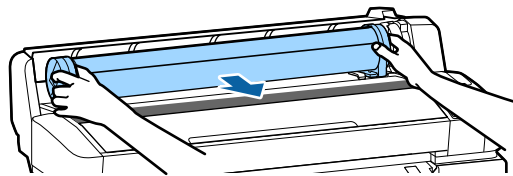

- 7** Lift the adapter lock levers to release the roll paper adapters.

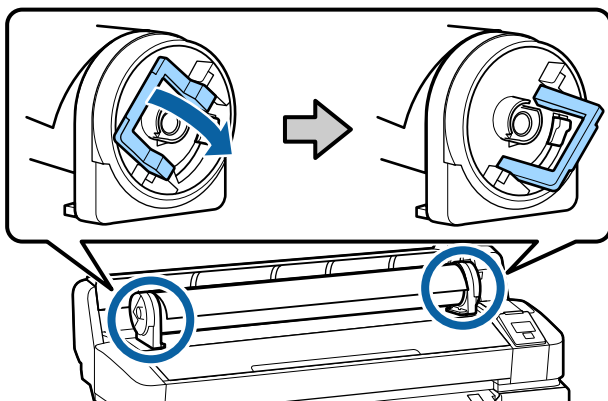

- 8** Remove the roll paper adapters.

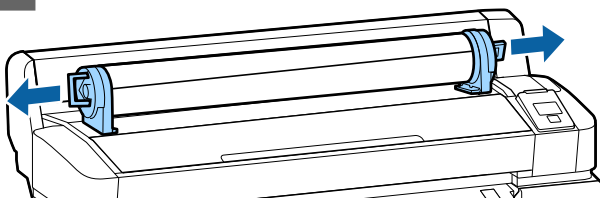

After rewinding the roll paper carefully, store it in the original package.

- 9** Close the roll paper cover.

## Settings for Loaded Paper

When you have finished loading the paper, follow the instructions on the control panel to make settings for the loaded paper.

**1. Set the paper type**

This is the most important setting for optimum print results. Failure to select an appropriate paper type that matches the loaded paper may cause problems such as wrinkling or scuffing.

**Remaining Setup**

The factory default setting is **ON**. You can change this to **OFF**.



**2. Set the paper length**

The approximate amount of paper remaining is determined from the length set here and the amount of paper used during print jobs. The amount of paper remaining is displayed in the information area on the **■** tab.

This setting screen is not displayed when Remaining Setup is set to **OFF**.

Buttons that are used in the following settings

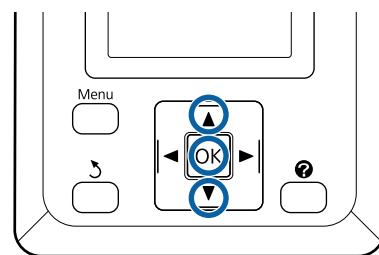

- 1** The previous settings for the paper type and amount remaining are displayed. Check that the print settings for the loaded paper use the paper setup number that you configured.

If you have loaded new paper that has not been setup, select an unassigned number, finish feeding the paper, and then perform paper setup.

## Basic Operations

Making Paper Settings  *User's Guide* (Online Manual)

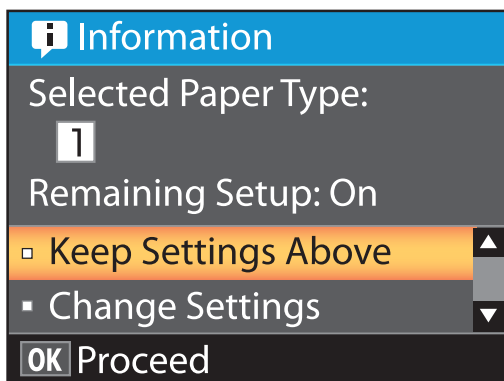

#### To print at current settings

Press the ▼/▲ buttons to highlight **Keep Settings Above** and press the OK button.

Proceed to Step 6.

#### To change settings

Press the ▼/▲ buttons to highlight **Change Settings** and press the OK button.

- 2 Highlight a setting you wish to change and press the OK button.
- 3 Highlight an option and press the OK button.
- 4 Press the ↻ button to return to the dialog shown in Step 2.
- 5 When settings are complete, highlight **Exit** and press the OK button.
- 6 If **ON** is selected for **Remaining Setup**, you will be prompted to enter the length of the roll. Press the ▼/▲ buttons to choose a value between 5.0 and 999.5m and press the OK button. Paper length is set in increments of 0.5 m.

After a short pause the printer will show **Ready**, indicating that it is ready to print. Transmit the data to be printed from a computer.

## Replacing Paper

This section describes how to replace paper. The procedure is displayed on the control panel screen. Follow these instructions.

Buttons that are used in the following settings

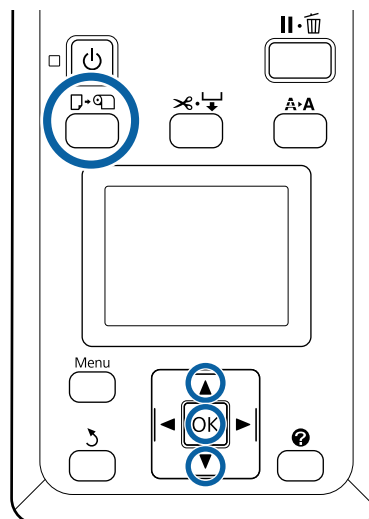

- 1 Confirm that the printer is ready and press the  button.  
The Load/Remove Paper menu will be displayed.
- 2 Press the ▼/▲ buttons to select roll paper, and then press the OK button.

#### Note:

To perform **Roll Paper Remaining**, you must enter the length of the roll paper when the roll paper is set. In order to perform accurate remaining roll paper management, we recommend opening the  tab and recording the amount of roll paper remaining when you replace the roll paper.

- 3 The roll rewinds automatically.

#### Note:

When the display shows **Turn roll paper adapter to wind up roll paper**, rewind the paper by hand.

- 4 Follow the on-screen instructions to load the roll paper for the next job.

# Maintenance

## When to Perform Various Maintenance Operations

### Regular maintenance

If you continue to use the printer without cleaning, it could cause clogged nozzles, ink drops, or color changes in the print results to occur.

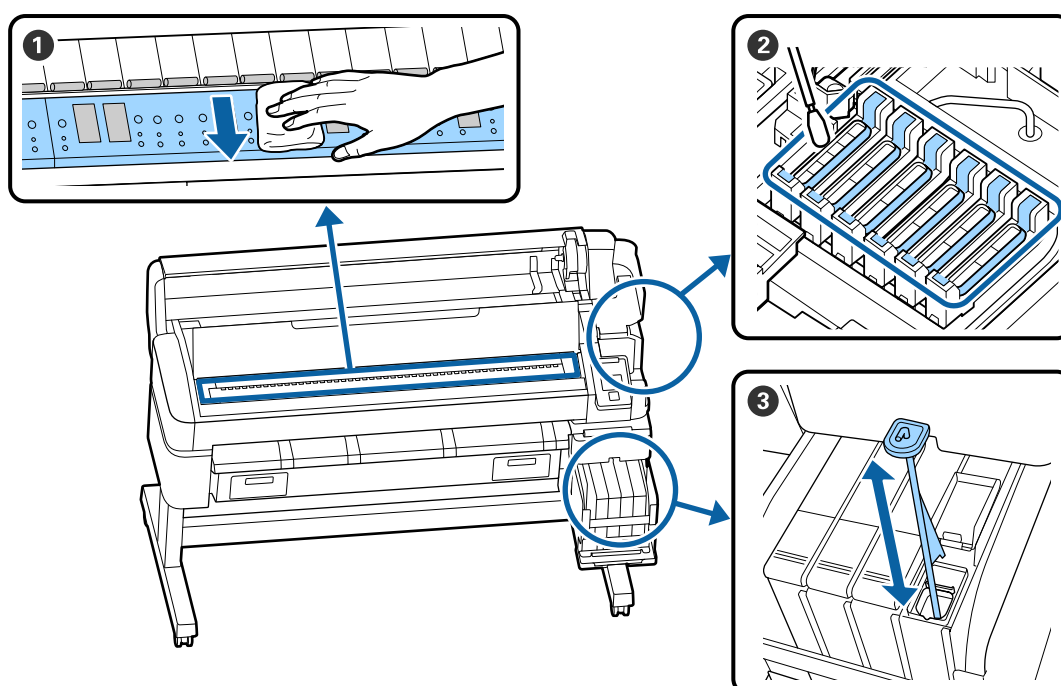

When to perform	Component to be cleaned
Once a week	<b>2 Cleaning caps</b> You can check the procedure in a video on YouTube. <a href="#">👉 Epson Video Manuals</a>
	<b>3 Stirring High Density Ink</b> When using high density ink, move the stirring stick up and down within one second and repeat about 15 times.
Once a month	<b>1 Cleaning the platen</b> <a href="#">👉 User's Guide (Online Manual)</a>

## Maintenance

 **Important:**

*The printer contains precision instruments. If any lint or dust adheres to the nozzles on the print head, print quality will decline.*

*Perform regular cleaning more frequently depending on the environment and paper being used.*

## Refilling and Replacing Consumables

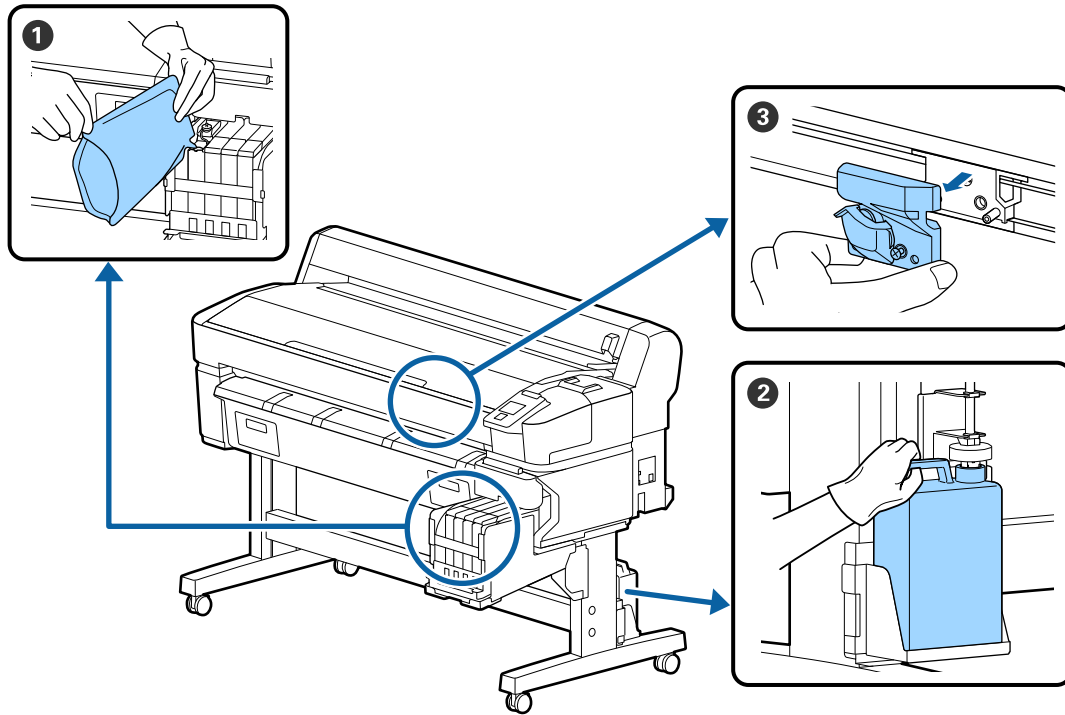

When to perform	Component to be replaced
If the remaining ink level is 50 mm or less:	<b>① Ink refill</b> <a href="#">☞ "Refilling ink" on page 20</a>
When a replacement message is displayed on the control panel	<b>② Waste Ink Bottle</b> <a href="#">☞ "Disposing of Waste Ink" on page 27</a>
The paper is not cut neatly/Cut edges are frayed	<b>③ Cutter</b> <a href="#">☞ User's Guide (Online Manual)</a>

## Performing maintenance when print quality declines

### When horizontal lines appear or the colors are wrong

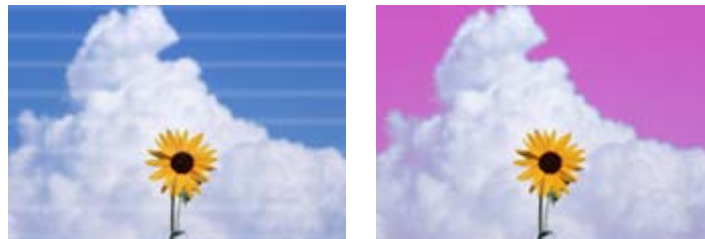

Perform the following sequence until the problems in the print results have improved.



## Maintenance

### 1. Perform head cleaning

You can choose between the following three levels for head cleaning; **Execute (Light)**, **Execute (Medium)**, or **Execute (Heavy)**.

At first, use **Execute (Light)**. Perform **Execute (Medium)** if there are faint or missing segments when you print a check pattern; if nozzles are still clogged, perform **Execute (Heavy)**.

 ["Clearing clogged nozzles" on page 28](#)



If print results do not improve even after performing head cleaning three times

### 2. Perform cap cleaning

Clean using the Cap cleaning kit supplied. See the following before cleaning.

 ["What You'll Need" on page 19](#)

 ["Precautions Regarding Maintenance" on page 19](#)

You can check the cleaning procedure in a video on YouTube.

 [Epson Video Manuals](#)



If print results do not improve even after cleaning the caps

### 3. Replace the wipers/wiper cleaner

You need the consumable wiper kit specifically for this printer when replacing. See the following before replacing.

 ["What You'll Need" on page 19](#)

 ["Precautions Regarding Maintenance" on page 19](#)

You can check the replacement procedure in a video on YouTube.

 [Epson Video Manuals](#)

If the print quality still does not improve, contact your dealer or Epson Support.

## If ink drops occur



Perform the following sequence until the problems in the print results have improved.

## Maintenance

### 1. Perform head cleaning

You can choose between the following three levels for head cleaning; **Execute (Light)**, **Execute (Medium)**, or **Execute (Heavy)**.

At first, use **Execute (Light)**. Perform **Execute (Medium)** if there are faint or missing segments when you print a check pattern; if nozzles are still clogged, perform **Execute (Heavy)**.

 ["Clearing clogged nozzles" on page 28](#)



If print results do not improve even after performing head cleaning three times

### 2. Clean the print head

You need the consumable Head Cleaning Set specifically for this printer when cleaning. See the following before cleaning.

 ["What You'll Need" on page 19](#)

 ["Precautions Regarding Maintenance" on page 19](#)

You can check the cleaning procedure in a video on YouTube.

 [Epson Video Manuals](#)

If the print quality still does not improve, contact your dealer or Epson Support.

## Maintenance

### What You'll Need

Ready the following items before beginning cleaning and replacement.

When the supplied parts have been completely used, purchase new consumables. Prepare genuine parts when replacing ink packs or performing maintenance.

 [“Information on Maintenance Items” on page 31](#)

If your gloves have worn out, prepare commercially available nitrile gloves.

#### Protective eyeglasses (available in the market)

Protects your eyes from ink and ink cleaner.

#### Mask (available in the market)

Protects your nose and mouth from ink and ink cleaner.

#### Cap cleaning kit (supplied with the printer)

Use for cleaning the caps.

The following items are in the kit.

When the supplied parts have been completely used, purchase new consumables.

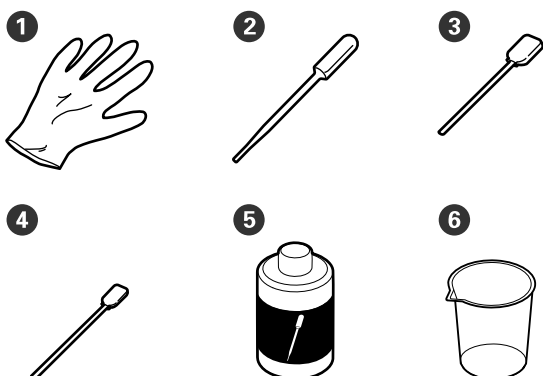

- ① Gloves (x2)
- ② Dropper (x2)
- ③ Cleaning sticks - Wide (x50)
- ④ Cleaning sticks - Narrow (x25)
- ⑤ Cap cleaning liquid (x1)

- ⑥ Cup (x1)

#### Head Maintenance Kit (Consumable item)

Use this to clean the print head.

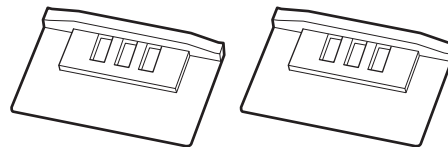

#### Wiper Kit (Consumable item)

This set contains replacement wipers and wiper cleaners.



- ① Gloves (x2)
- ② Wipers (x2)
- ③ Wiper cleaners (x2)

#### Metal or plastic (PP/PE) tray (available in the market)

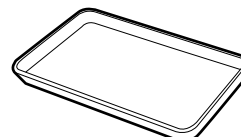

Use when putting cleaning utensils, removed consumables, or cap cleaning liquid moved in the cup supplied with the printer.

#### Soft cloth (available in the market)

Use for cleaning the platen. Use material that is not likely to generate lint or static electricity.

### Precautions Regarding Maintenance

Note the following points when cleaning and replacing parts.

## Maintenance

### **Caution:**

- ❑ *During maintenance, wear protective clothing, including protective eyewear, gloves, and a mask.  
If ink, waste ink, or cap cleaning liquid comes into contact with your skin or enters your eyes or mouth, immediately take the following actions.*
    - ❑ *If fluid adheres to your skin, wash it off using large volumes of soapy water. If you notice any reaction developing in the affected area, consult with a qualified physician immediately.*
    - ❑ *If ink gets into your eyes, wash them out immediately with water. Failure to observe this precaution could result in bloodshot eyes or mild inflammation. Consult with a qualified physician if any other problems should develop.*
    - ❑ *If fluid enters your mouth, consult with a physician as soon as possible.*
    - ❑ *If swallowed, do not induce vomiting. Consult with a physician as soon as possible. If vomiting is induced, vomited material may enter the windpipe, which is dangerous.*
  - ❑ *Store ink packs, waste ink, and cap cleaning liquid in a location out of reach of children.*
- 
- ❑ Remove the paper from the printer before proceeding.
  - ❑ Never touch the belts, circuit boards, or any parts that do not require cleaning. Failure to observe this precaution could result in malfunction or reduced print quality.
  - ❑ Do not use anything other than the supplied or consumable cleaning stick. Other types of stick that produce lint will damage the print head.
  - ❑ Always use fresh cleaning sticks. Re-using sticks can make stains even harder to remove.
  - ❑ Do not touch the tips of the cleaning sticks. Oil from your hands could damage the print head.

- ❑ Do not use anything other than the cap cleaning liquid specified to clean the caps. Using anything else could result in malfunction or reduced print quality.
- ❑ Touch a metallic object before starting work to discharge any static electricity.

## Refilling ink

### Time Period for Ink Refills

If the **Check Ink Levels** message is displayed on the control panel screen, immediately do the following two points.

- ❑ Prepare an ink pack of the appropriate color.
- ❑ Check the remaining ink level, and if it is 50 mm or less from the bottom of the ink tank, replace the chip unit and refill the ink.

You will be unable to print if **Refill Ink Tank** appears for even one color. If the **Check Ink Levels** message is displayed in the middle of a print job, you can replace the chip unit and refill the ink as printing continues.

Supported Ink Packs  [“Information on Maintenance Items” on page 31](#)

### **Important:**

*This printer is equipped with a remaining ink warning system. Information about the available amount of ink in one pack is recorded in the chip unit supplied with a new ink pack. By installing a new chip unit on the printer, this information is written to the printer.*

*The warning system for remaining ink estimates the remaining ink based on the information written to the printer for one pack of ink and the ink usage conditions, and then displays a message. To maintain the accuracy of this system, you must replace the chip unit and refill the ink as soon as possible once the remaining ink is 50 mm or less from the bottom of the ink tank.*

## Maintenance

### Charging and reserving chip units

Writing the information about available amount of ink in one ink pack when a chip unit is installed on the printer is called “charging”. After charging, the chip unit that was installed on the printer can be replaced with the chip unit supplied with the next new ink pack. Replacing a new chip unit after charging is called “reserving”. By reserving, the information about the available amount of ink in one ink pack is automatically charged to the printer from the reserved chip unit simultaneously when the charge is gone. Reserving can be done at any time if the indicator's level for the estimated amount of ink is between 1 and 6.

When reservation is performed, a warning is not displayed when the estimated amount of ink becomes low. Refill the ink with one pack of ink if the remaining ink is 50 mm or less from the bottom of the ink tank. See steps 2 to 6 on the following page for the procedure to replace the chip units.

You can confirm whether or not a chip is reserved by the status icons of the chip units.

 *User's Guide* (Online Manual)

---

### Procedure for Ink Refills

The refill method differs depending on the type of ink. Use the refill method that matches the type of ink.

Before performing operations, check the “Safety data sheet” and the following notes.

You can download it at your local Epson Web site.



#### **Caution:**

- ❑ *Store ink packs and waste ink in a location out of reach of children.*
- ❑ *Wear protective eyewear, gloves, and a mask when performing maintenance. Should ink or waste ink contact your skin or enter your eyes or mouth, take the following actions:*
  - ❑ *If fluid adheres to your skin, wash it off using large volumes of soapy water. If you notice any reaction developing in the affected area, consult with a qualified physician immediately.*
  - ❑ *If ink gets into your eyes, wash them out immediately with water. Failure to observe this precaution could result in bloodshot eyes or mild inflammation. Consult with a qualified physician if any other problems should develop.*
  - ❑ *If fluid enters your mouth, consult with a physician as soon as possible.*
  - ❑ *If swallowed, do not induce vomiting. Consult with a physician as soon as possible. If vomiting is induced, vomited material may enter the windpipe, which is dangerous.*
- ❑ *Be aware of the following points when refilling ink.*
  - ❑ *Carefully cut open the nozzle on the ink pack. If too much force is applied, the ink may splatter out.*
  - ❑ *Do not grip the ink pack too strongly after opening. This may cause the ink to be squeezed out of the pack.*
  - ❑ *When pouring the ink into the ink tank, slowly tilt the ink pack to pour.*

Maintenance

**! Important:**

- ❑ *Epson recommends the use of genuine Epson ink packs. Epson cannot guarantee the quality or reliability of nongenuine ink. The use of non-genuine ink may cause damage that is not covered by Epson's warranties, and under certain circumstances, may cause erratic printer behavior. Information about non-genuine chip unit status may not be displayed, and use of non-genuine ink is recorded for possible use in service support.*
- ❑ *Genuine Epson ink, other than those specified here, could cause damage that is not covered by Epson's warranties.*  
*☞ "Ink packs" on page 31*
- ❑ *Do not place items on the ink tank or subject the ink tank to strong impacts. The ink tank could be detached. Contact your dealer or Epson Support.*
- ❑ *Do not use if the High Density Black and Black inks are mixed. When changing the type of Black ink being used, the ink tank should only be changed by a service engineer. Changing the type of Black ink is provided for a fee. Contact your dealer or Epson Support.*

**When the amount of ink remaining is above the top edge of the metal plate**

You cannot empty the entire new ink pack into the ink tank. Continue use until the ink level reaches the top edge of the metal plate.

**When the amount of ink remaining is below the top of the hole**

When the amount of ink remaining drops below the top of the hole, the amount remaining may be less than the minimum value and printing may stop. Refill the ink right away.

**! Important:**

*When the remaining ink is above the top edge of the hole and a message appears stating **Refill Ink Tank**, it is time to replace the ink tank. Replace the ink tanks. Replacements and repairs will be provided for a fee.*

*During replacements and repairs, the ink in the ink tank is discarded. This is necessary because fine dirt, dust and other foreign bodies mixed the ink in the ink tank cause the ink tank to malfunction.*

*The ink tank replacement interval depends on the usage environment and conditions.*

*Contact your dealer or Epson Support.*

- 1 When **Check Ink Levels** is displayed on the control panel screen, check the ink level in the ink tank.

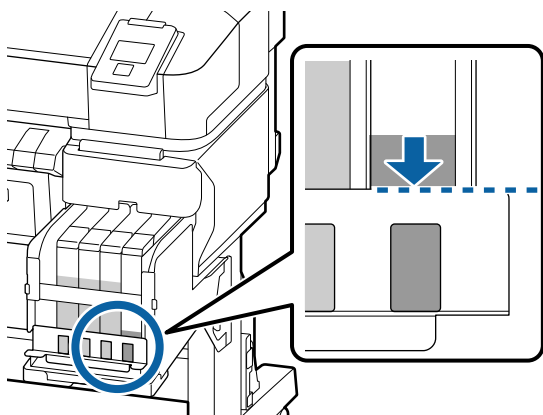

Make sure the ink level is below the top edge of the metal plate.

Proceed to step 7 if the status of the chip unit on the control panel is reserved. Proceed to step 2 if it is not reserved.

- 2 Open the side cover.

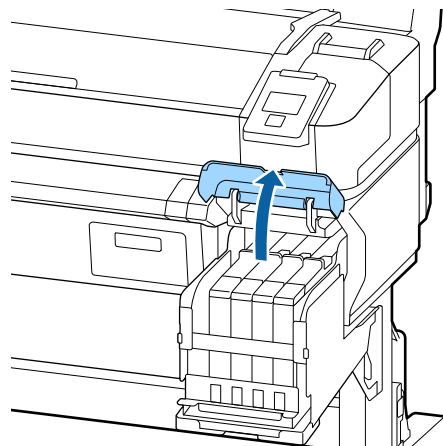

## Maintenance

- 3** Hook a finger into the indentation on top of slider and pull it straight out.

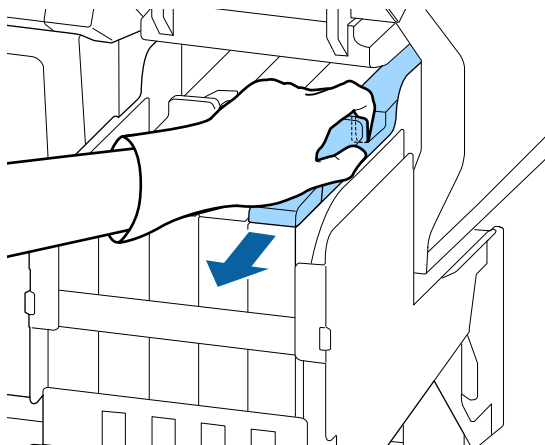

**!** **Important:**

*Do not tilt the slider. Dropping the chip unit may damage it.*

- 4** Remove the chip unit from the slider.

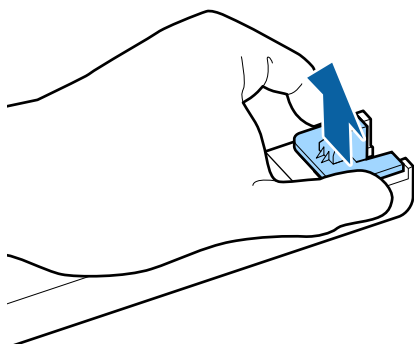

- 5** Install the chip unit that comes with the new ink pack.

During installation, check to ensure that the labels on the slider and the chip unit are the same color.

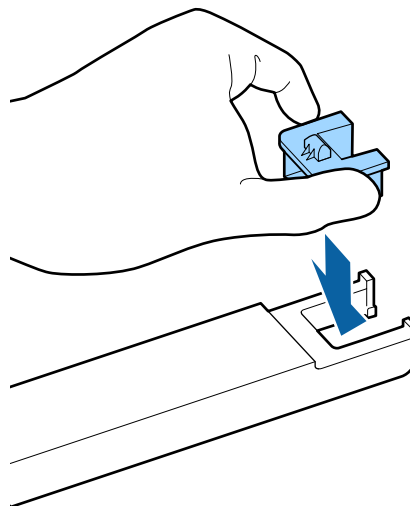

- 6** Hold the slider level horizontally and insert it.
- Close the side cover.

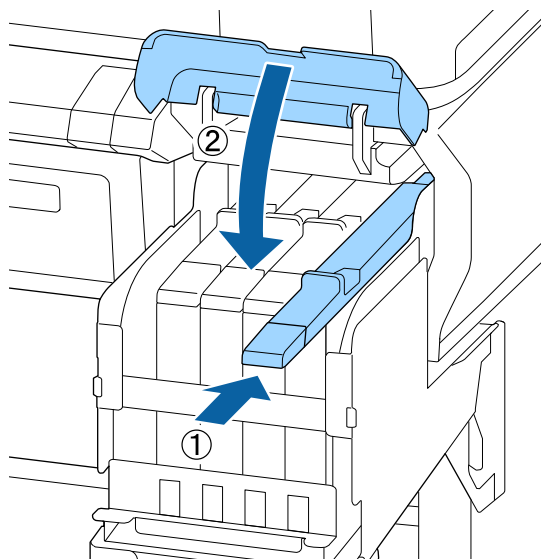

**!** **Important:**

*Do not push the slider in with excessive force. This can cause damage.*

Maintenance

- 7 Shake the new ink pack for 5 seconds 15 times horizontally in approximately 5 cm movements as shown in the illustration.

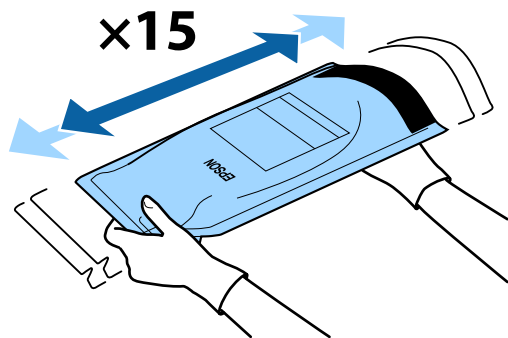

- 8 Check that no warnings or errors are displayed on the control panel screen before opening the inlet cover of the slider.

If an error or a warning is displayed, follow the messages to resolve the error or warning, and then proceed with the following operation.

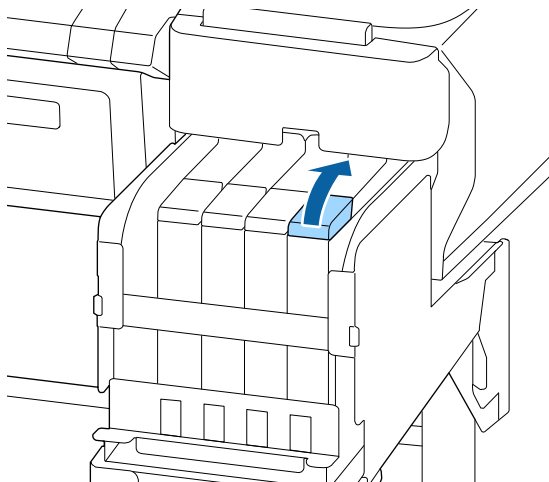

- 9 Remove the ink inlet cap from the ink tank.  
The method for removing the ink inlet cap differs depending on the type of ink being refilled.



**Important:**

*Remove the ink inlet cap slowly. If you remove the cap too quickly, ink may splatter.*

**Except for High Density Black ink**

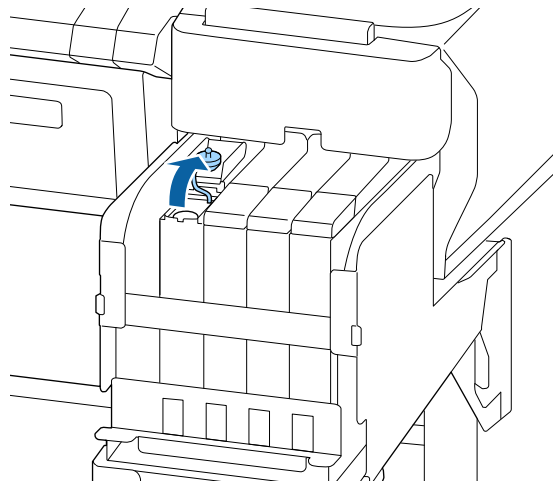

**For High Density Black ink**

- (1) Hold the part shown in the circled area in the illustration to remove the ink inlet cap. If the ink inlet cap is removed with any other part, ink adheres.



Maintenance

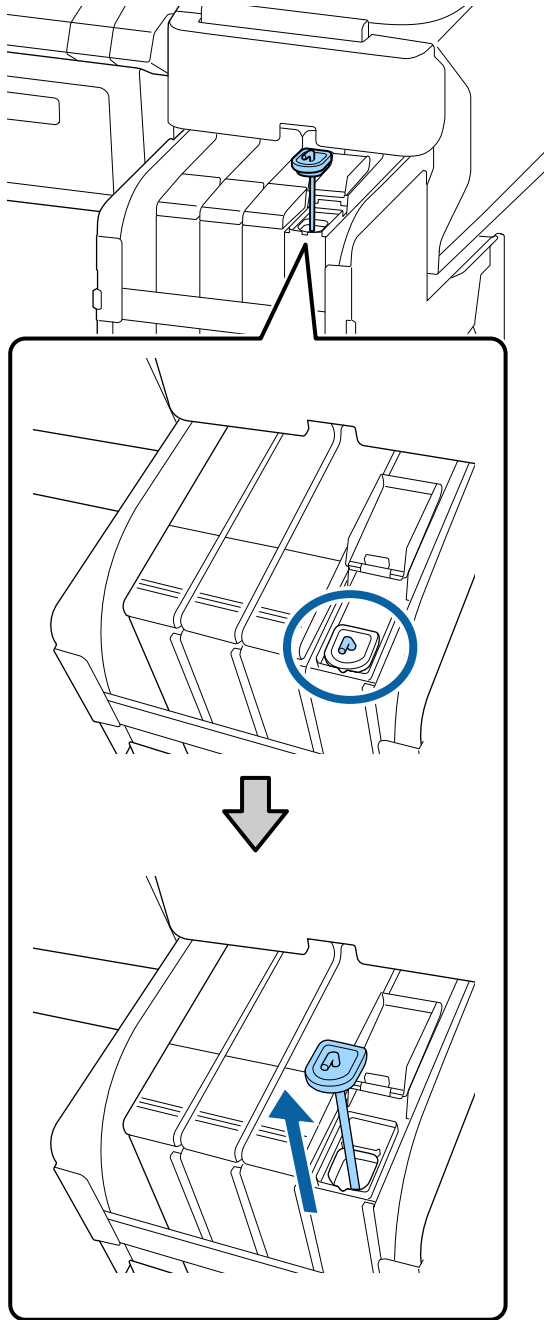

(2) Hook the stirring stick over the projection on the ink tank.

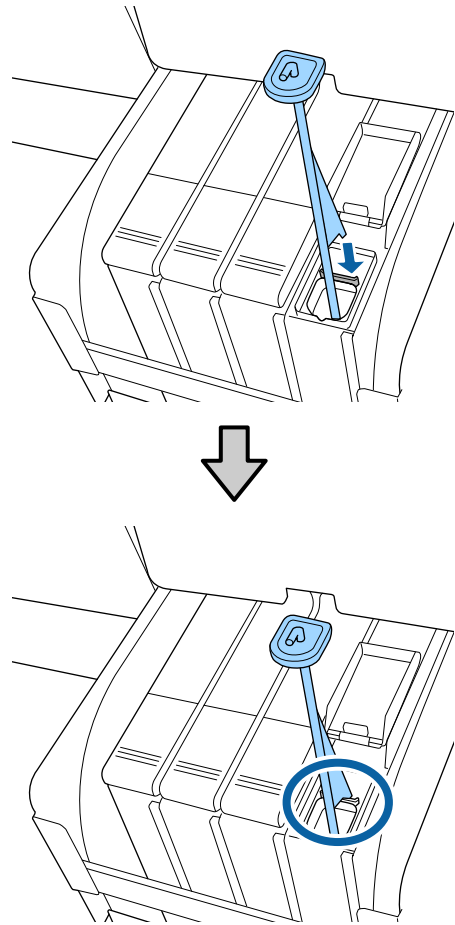

10 Tear off the ink pack spout opening.

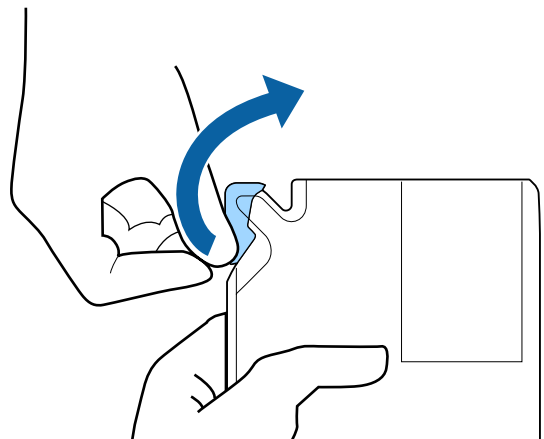

Maintenance

- 11** Fill the ink tank with the ink from the ink pack. Insert the spout of the ink pack into the ink tank ink inlet groove and slowly tilt to pour out the ink.

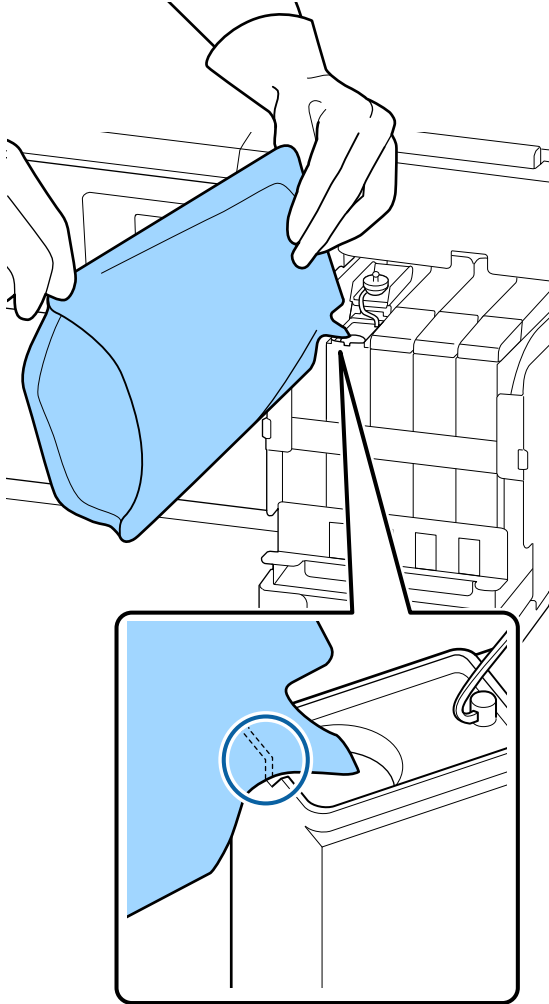

**!** **Important:**

Use all of the ink in the ink pack for a single refill.

Do not use the ink in an ink pack to refill multiple different ink tanks.

This can cause messages from the remaining ink warning system to not be displayed properly.

- 12** Put the ink inlet cap back on the ink tank. The method for attaching the ink inlet cap differs depending on the type of ink being refilled.

**Except for High Density Black ink**

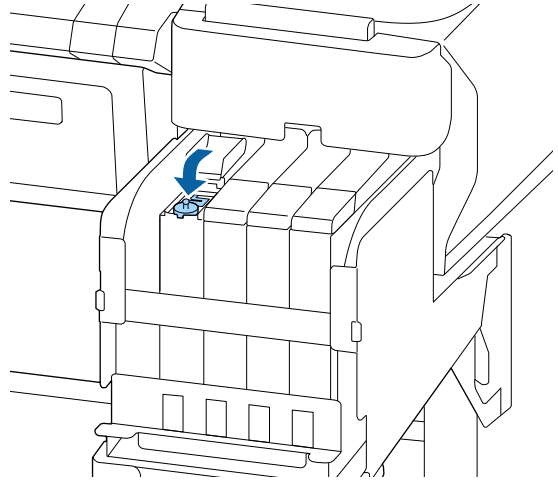

**For High Density Black ink**

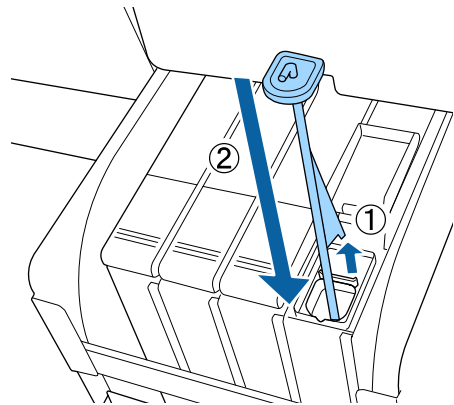

**!** **Important:**

Press the ink inlet cap down firmly so that it does not detach. If the slider comes into contact with the ink inlet cap when pulling it out, the cap could be damaged.

- 13** Close the ink inlet cover.

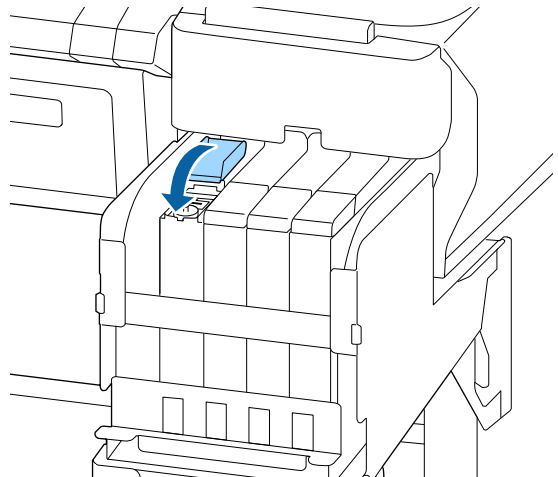

## Disposing of Waste Ink

### Preparing and Replacement Timing

#### Prepare empty waste ink bottle. is displayed

prepare a new Waste Ink Bottle as soon as possible.

When you want to replace the Waste Ink Bottle at this stage due to night operations and so on, select **Replace Ink Bottle** from the setup menu, and then replace the bottle. If you perform the replacement without selecting **Replace Ink Bottle**, the waste ink counter will not operate correctly.

Details on the setup menu [☞ User's Guide \(Online Manual\)](#)

Waste Ink counter [☞ "Waste Ink Counter" on page 27](#)

#### **!** Important:

*Never remove the Waste Ink Bottle while printing or while the heads are being cleaned, unless there are on-screen instructions. Waste ink may leak.*

#### Replace waste ink bottle and press **OK**. is displayed

Replace the Waste Ink Bottle with a new bottle immediately.

Replacement procedure [☞ "Replacing the Waste Ink Bottle" on page 27](#)

### Waste Ink Counter

The printer uses the waste ink counter to track waste ink and displays a message when the counter reaches the warning level. When you follow the message, **Replace waste ink bottle and press **OK****. to replace the Waste Ink Bottle with a new one, the counter is cleared automatically.

If you need to replace the waste ink bottle before the message is displayed, select **Replace Ink Bottle** from the setup menu.

[☞ User's Guide \(Online Manual\)](#)

#### **!** Important:

*If you replace the Waste Ink Bottle before being prompted by a message, always clear the waste ink counter. Otherwise, Waste Ink Bottle replacement time will not be notified correctly from the next message.*

### Replacing the Waste Ink Bottle

Follow the procedure below to replace the parts.

Before starting this procedure, be sure to read the following:

[☞ "Precautions Regarding Maintenance" on page 19](#)

1

Remove the Waste Ink Bottle from the Waste Ink Bottle holder.

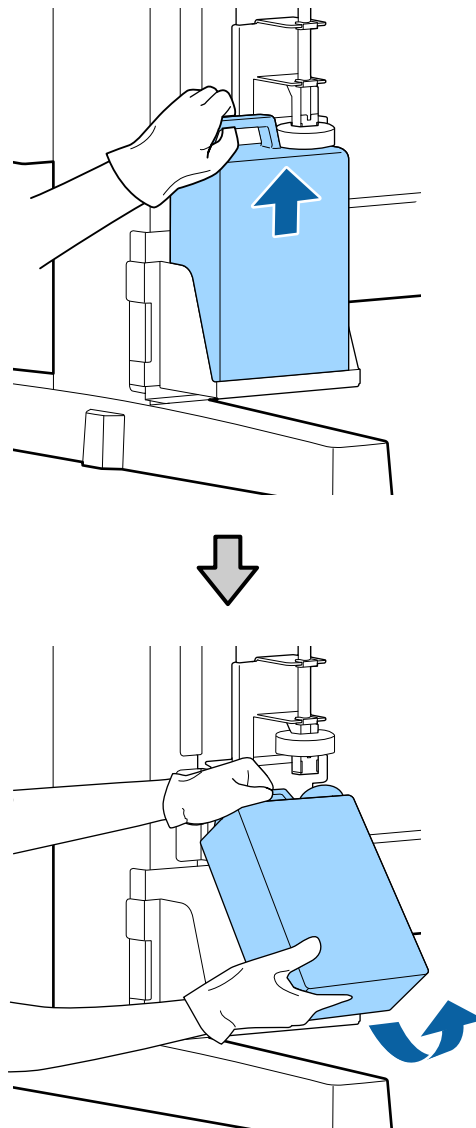

Maintenance

If the back of the stopper is stained, wipe it.

- 2 Insert the waste ink tube into the mouth of the new Waste Ink Bottle and place the Waste Ink Bottle in the holder.

Tightly seal the lid on the used Waste Ink Bottle.

**! Important:**

- Be sure to confirm that the waste ink tube is inserted in the mouth of the waste ink bottle. Ink will spill onto the surrounding area if the tube is not inserted in the bottle.
- You will need the lid for the Waste Ink Bottle when disposing of waste ink. Keep the lid in a safe place; do not throw it out.

- 3 Lower the stopper.

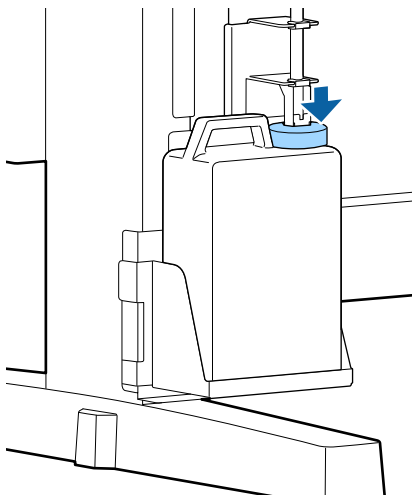

**! Important:**

Check that the stopper is stuck close to the mouth of the bottle. If there is a gap, waste ink may splatter and stain the surrounding area.

- 4 Press the OK button.

- 5 Check again to confirm that a new waste ink bottle is correctly placed. Press the OK button to clear the waste ink counter.

[📖 “Handling Used Consumables” on page 30](#)

## Clearing clogged nozzles

Check and perform the following in sequence until the clogged nozzles are cleared.

### Checking for clogged nozzles

Print a check pattern and then check the following content.

- Are there any clogged nozzles?
- Which nozzle rows are clogged?



If nozzles are clogged

### Perform head cleaning (light)

There are three levels of head cleaning available; light, medium, and heavy.

Perform **Execute (Light)** and then print a check pattern. Use the pattern to check if the clogged nozzles have been cleared.



If nozzles are still clogged

### Perform head cleaning (medium)

Perform **Execute (Medium)** and then print a check pattern. Use the pattern to check if the clogged nozzles have been cleared.



If nozzles are still clogged

### Perform head cleaning (heavy)

Perform **Execute (Heavy)** and then print a check pattern. Use the pattern to check if the clogged nozzles have been cleared.



If nozzles are still clogged

The printer requires internal cleaning.

Perform the following according to the status of print results.

When horizontal lines appear or the colors are wrong

## Maintenance

You can check the cleaning procedure in a video on YouTube.

[Epson Video Manuals](#)

If ink drops occur

You can check the cleaning procedure in a video on YouTube.

[Epson Video Manuals](#)

## Printing a Check Pattern

Buttons that are used in the following settings

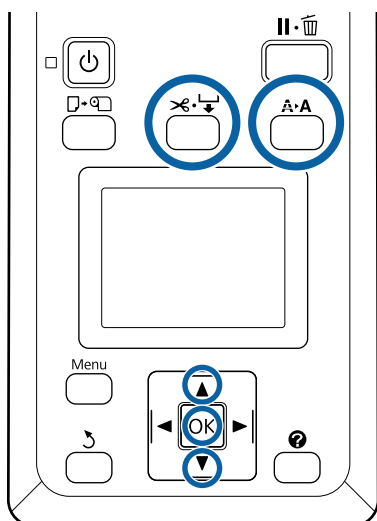

- 1** Confirm that the printer is ready to print. Press the **A·A** button.  
The Maintenance menu will be displayed.
- 2** Confirm that **Nozzle Check** is highlighted and press the **OK** button.  
A confirmation dialog will be displayed.
- 3** Press the **OK** button to print a check pattern.
- 4** Inspect the nozzle pattern.  
When paper is loaded in the optional auto take-up reel unit, the paper is not cut automatically after printing the check pattern. If the check pattern is hard to see, you can feed the paper using the following procedure and then check.
  - (1)** Press the **⏏** button.

- (2)** Press the **▼** button to feed the paper until the check pattern is easily visible.
- (3)** After checking the check pattern, press the **▲** button to rewind the paper.
- (4)** Press the **⏏** button to return to the menu.

### Example of clean nozzles

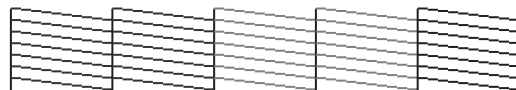

There are no gaps in the nozzle check pattern.

Select **Exit**, and then press the **OK** button to close the settings menu.

### Example of clogged nozzles

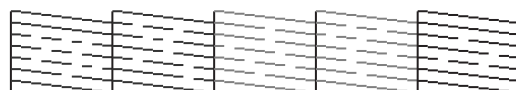

Perform head cleaning if parts of the pattern are missing.

[“Head Cleaning” on page 29](#)

### **!** Important:

*Always remove clogs from the nozzles of all colors before resuming use. If clogged nozzles (including clogged nozzles for colors that are not used) remain when printing after resuming use, the clogs can no longer be removed.*

## Head Cleaning

If there are faint or missing areas in the check pattern, you may be able to unclog the nozzles by cleaning the print head.

There is no need to clean the head if the print result does not contain faint areas or other color problems.

## Maintenance

### Head cleaning procedure

Buttons that are used in the following settings

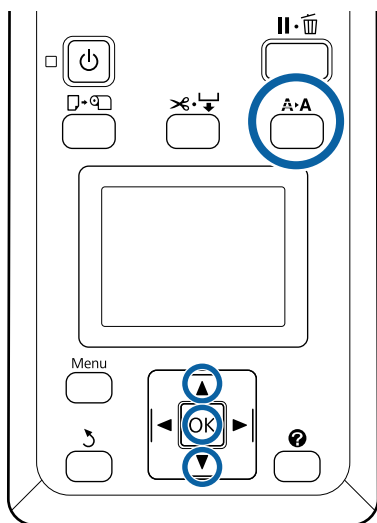

- 1 Confirm that the printer is ready to print. Press the **A·A** button.

The Maintenance menu will be displayed.

- 2 Press the **▼/▲** buttons to highlight **Head Cleaning** and press the OK button.

- 3 Select the method for specifying the nozzle rows for cleaning.

#### All Nozzles

Inspect the printed pattern and select this method if all patterns contain faint or missing areas. If you selected **All Nozzles**, skip ahead to Step 5.

#### Selected Nozzles

Inspect the printed pattern and select this method if only certain pattern numbers (nozzle rows) contain faint or missing areas. You can select multiple nozzle rows.

- 4 Select nozzle rows for cleaning.
  - Press the **▼/▲** buttons to highlight numbers corresponding to check patterns with faint or missing segments and press the OK button to select.
  - Once you have selected all the nozzle rows for head cleaning, highlight **Proceed** and press the OK button.

- 5 Select the cleaning level, then press the OK button.

At first, use **Execute (Light)**.

- 6 Head cleaning will be performed.  
After performing had cleaning, review the printed check pattern to confirm that all heads have been cleaned.

## Handling Used Consumables

The following used parts with adhered ink are classified as industrial waste.

- Cleaning stick
- Wiper
- Wiper cleaner
- Cap cleaning liquid
- Ink packs
- Waste ink
- Waste Ink Bottle
- Head Maintenance Kit
- Paper after printing

Dispose of items according to local laws and regulations. For example, contract a industrial waste disposal company for disposal. In such cases, submit the "Safety data sheet" to the industrial waste disposal company.

You can download it at your local Epson Web site.

# Information on Maintenance Items

For the latest information, see the Epson Web site. (As of February, 2019)

## Ink packs

 **Important:**

*Using ink from an undesignated ink pack may result in a malfunction.*

*Epson shall not be held responsible for any damages or problems with the printer that may occur when using undesignated, non-genuine ink packs.*

Printer model	Product name		Part number
SC-F6300 SC-F6360	Ink packs	Black	T46D1
		Cyan	T46D2
		Magenta	T46D3
		Yellow	T46D4
		High Density Black	T46D8
SC-F6330	Ink packs	Cyan	T46H2
		Magenta	T46H3
		Yellow	T46H4
		High Density Black	T46H8
SC-F6340	Ink packs	Cyan	T46G2
		Magenta	T46G3
		Yellow	T46G4
		High Density Black	T46G8
SC-F6380	Ink packs	Black	T46F1
		Cyan	T46F2
		Magenta	T46F3
		Yellow	T46F4
		High Density Black	T46F8

Epson recommends the use of genuine Epson ink packs. Epson cannot guarantee the quality or reliability of nongenuine ink. The use of non-genuine ink may cause damage that is not covered by Epson's warranties, and under certain circumstances, may cause erratic printer behavior. Information about non-genuine chip unit status may not be displayed, and use of non-genuine ink is recorded for possible use in service support.

## Information on Maintenance Items

### Others

Product name	Product number	Explanation
Waste Ink Bottle	T7240	Identical to the Waste Ink Bottle supplied with the printer.
Head Maintenance Kit (except for SC-F6380)	S210042	Use this to clean the print head.
Head Maintenance Kit (for SC-F6380)	S210043	
Cap Cleaning Kit (except for SC-F6380)	S210053	This is the same as the Cap cleaning kit supplied with the printer.
Cap Cleaning Kit (for SC-F6380)	S210054	
Wiper Kit (except for SC-F6380)	S210095	This contains replacement wipers and wiper cleaners.
Wiper Kit (for SC-F6380)	S210096	
Auto Cutter Spare Blade	S902006	This is a replacement cutter.